

Installation Instructions

LEVER OPERATED SEQUENTIAL THERMOSTATIC WALL MOUNTED SHOWER MIXER



CONTOUR 21: A4130AA

*Armitage
Shanks*

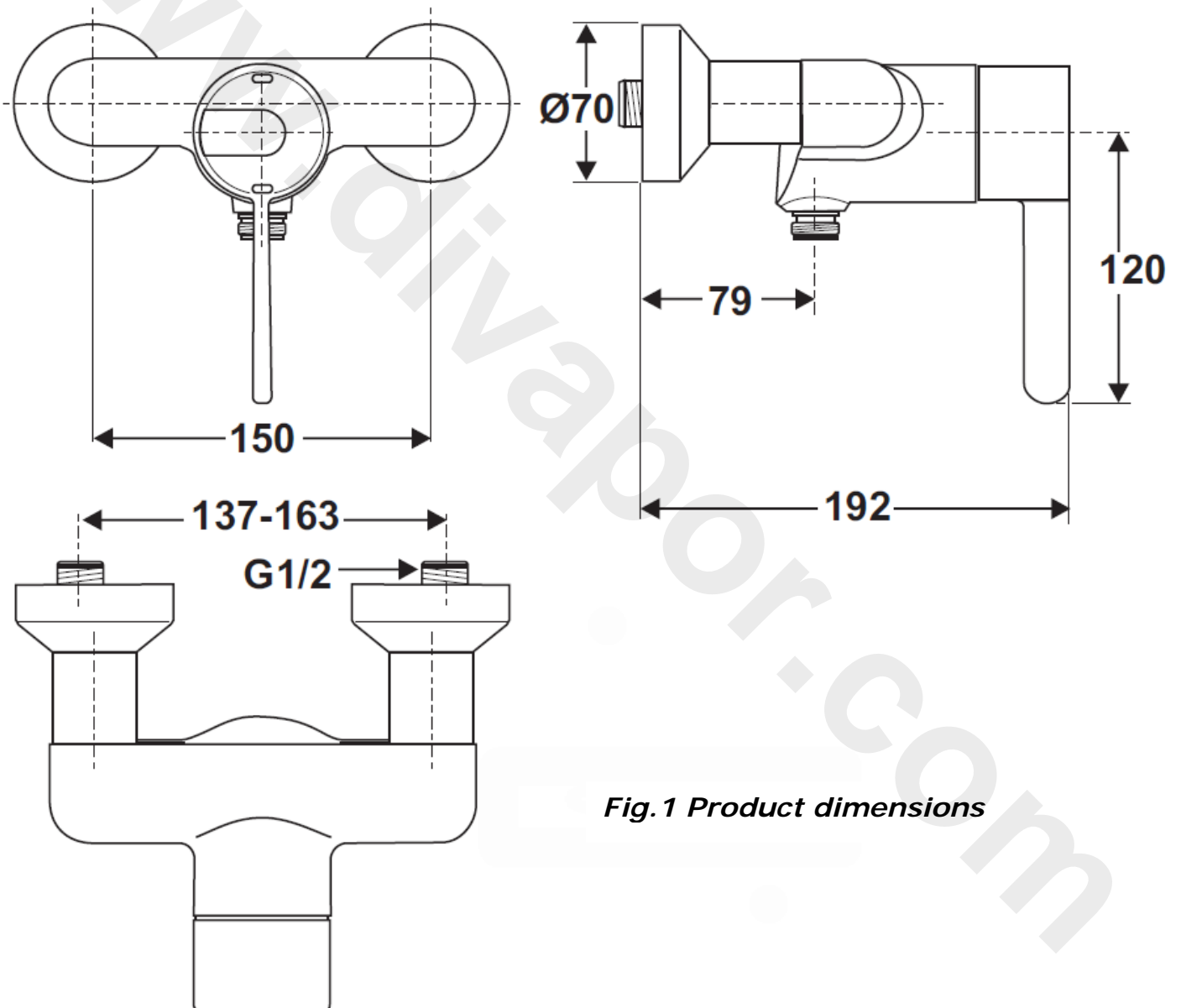

Fig.1 Product dimensions

INSTALLER: After installation please pass this instruction booklet to user

The fittings covered by this installation and maintenance instruction should be installed in accordance with the water regulations published in 1999*, therefore Armitage Shanks would strongly recommend that these fittings are installed by a professional installer

*A guide to the Water Supply (Water Fittings) Regulations 1999 and the Water Byelaws 2000, Scotland is published by WRAS (Water Regulations Advisory Scheme) Fern Close, Pen-y-Fan Industrial Estate, Oakdale, Newport, NP11 3EH. ISBN 0-9539708-0-9

2 DESCRIPTION

A4130AA CONTOUR 21 SEQUENTIAL THERMOSTATIC LEVER OPERATED WALL MOUNTED SHOWER MIXER

This manual covers the A4130AA Contour 21 thermostatically controlled, lever operated, sequential, wall mounted shower mixer. This mixer is designed to provide water from ambient cold up to a safe maximum temperature for showering and hand washing respectively.

It is intended to be surface mounted on in-wall plumbing where the horizontal centres of the pipe work are in the range 137mm - 163mm and is delivered complete with integral check valves and isolating valves.

Avoid using heat for soldering near the mixer inlets to prevent damage to internal components.

3 DIMENSIONS

Product dimensions are shown on front page, see Fig. 1.

4 WATER SUPPLY CONDITIONS

4.1 INTRODUCTION

This sequential thermostatic lever operated mixer is manufactured to the highest standards and has approval to TMV3 which permits it to be installed in healthcare establishments such as hospitals, nursing homes and residential care homes. When installed in healthcare establishments the supply conditions detailed in Table 1 must be observed and the commissioning and servicing requirements detailed on section 7 & 8 must be followed.

For other installations this is not a requirement.

4.2 SUPPLY PRESSURE REQUIREMENTS

This mixer is designed to be installed on all types of plumbing systems.

Hot and cold water supply pressures should be reasonably balanced, however, the mixer will function within specification on unequal pressures up to 5 :1.

The fitting should be so installed as to permit the operation of the isolating valves and give access for servicing the strainer elements.

The minimum pressure for correct operation is 0.2 bar.

4.3 HEALTHCARE ESTABLISHMENTS

In accordance with the NHS model engineering specifications DO8 this valve has approval for the following applications:-

High pressure - HP - WE
Low pressure - LP - WE

For this type of application the following supply conditions must apply:

Operating pressure range	High pressure	Low pressure
Maximum static pressure - Bar	10	10
Flow pressure hot and cold - Bar	1 to 5	0.2 to 1
Hot supply temperature *	55°C to 65°C	55°C to 65°C
Cold supply temperature	5°C to 20°C	5°C to 20°C

Note:

Fittings operating outside these conditions cannot be guaranteed by the scheme to operate as TMV3.

← ***52°C absolute minimum can be used but not recommended**

Table 1 Supply conditions for healthcare establishments

Effectively this means:

Differential between HOT and COLD inlet temperatures (Δt) must be 32C° min and 60C° max

Differential between HOT inlet temperature and MIXED temperature (Δt)

must be 11C° absolute minimum but > 14C° preferred

See 7.3 Audit checks on TMV's.

5 INSTALLATION

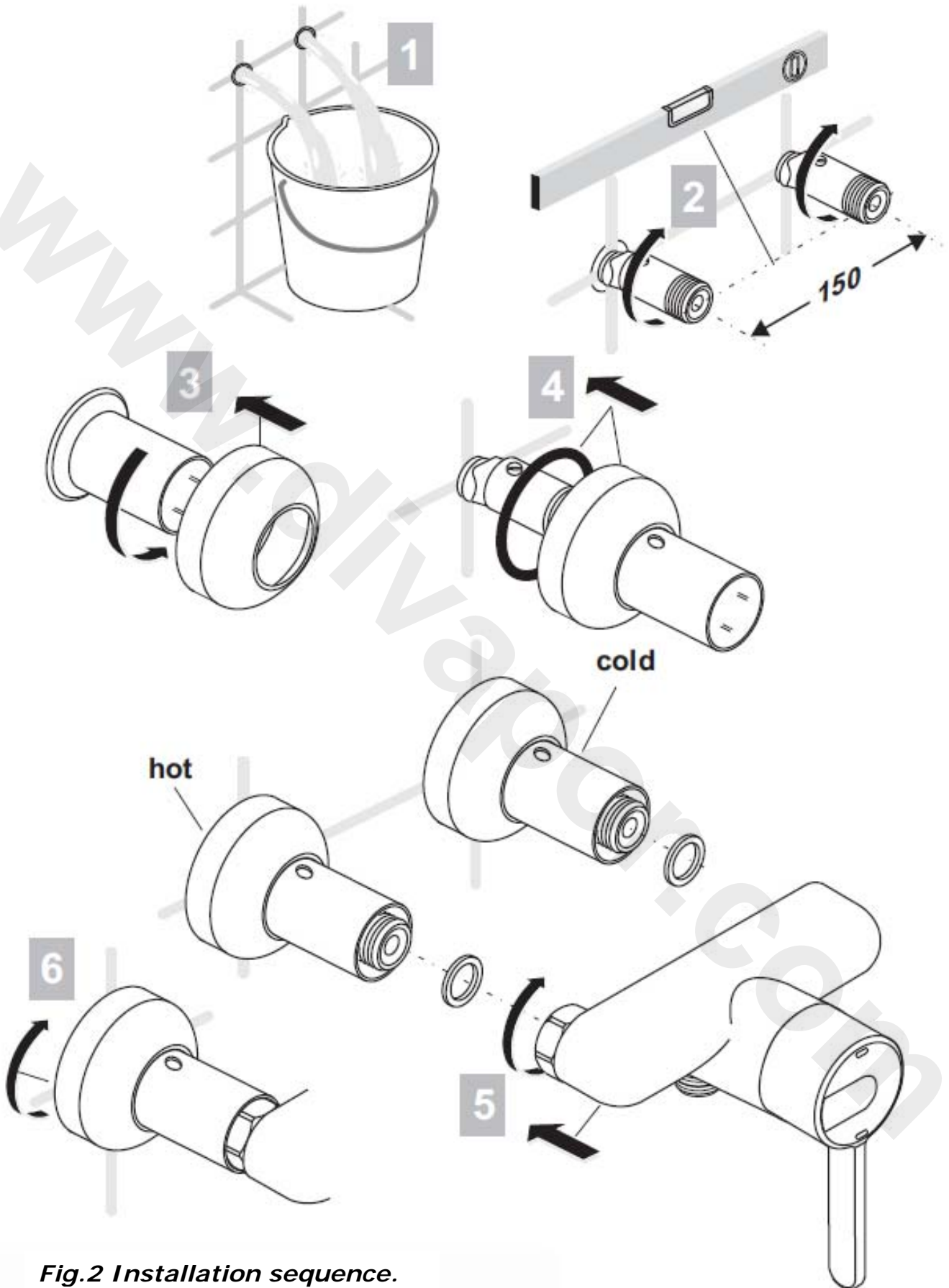

Fig.2 Installation sequence.

IMPORTANT NOTE:

Before connecting the product to the supplies, it is strongly recommended to flush the supply pipe-work to remove any residues or debris remaining after installation.

After connecting supplies, ensure all joints are tight and check for leaks.

6 OPERATION

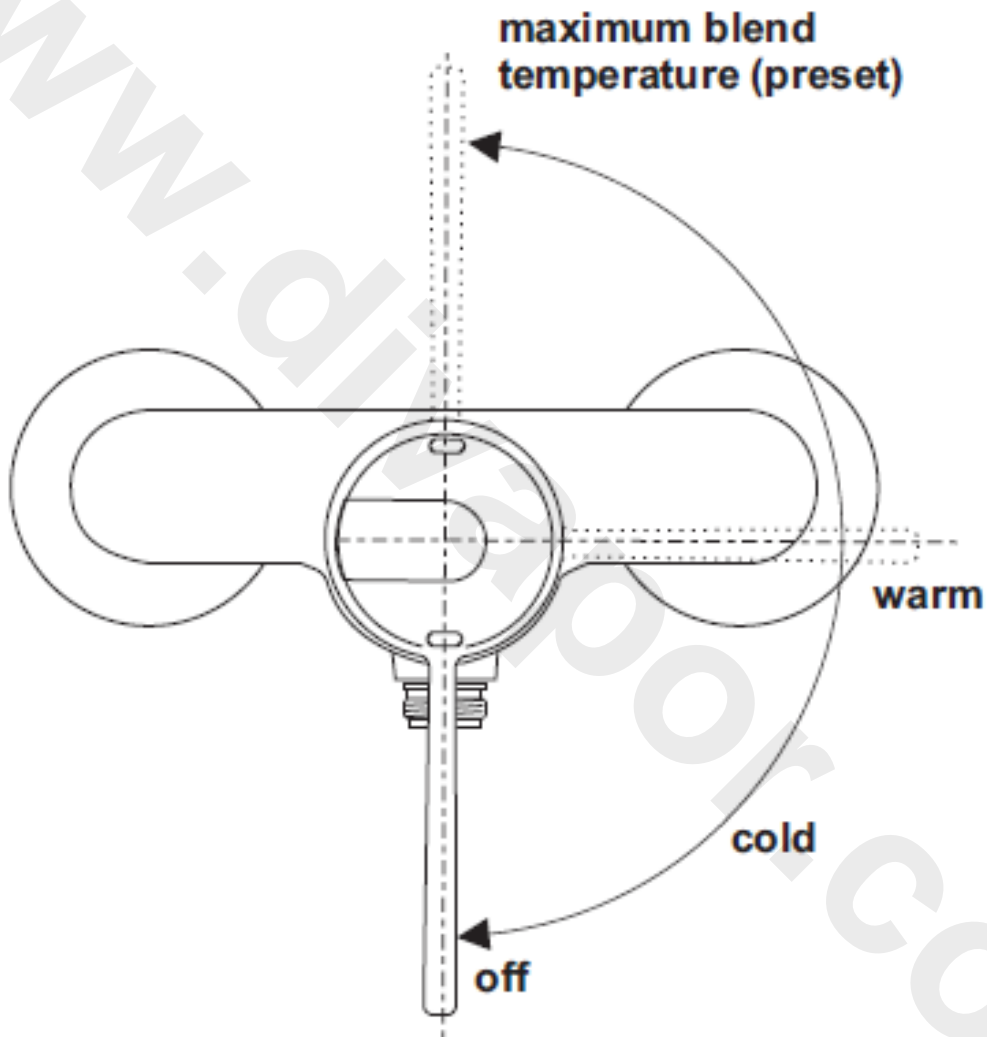

Figure .3 Showing the handle control positions.

As the handle is rotated anti-clockwise from the off position the delivered water progresses from cold through warm to the preset maximum temperature of approximately 41°C

When installed as a TMV3 application it is a requirement that the commissioning and maintenance procedures detailed *in sections 7 & 8 be carried*

For non healthcare installations these checks are not a requirement.

7 COMMISSIONING AND AUDITS

The following procedure should be conducted after installation to ensure the product is functioning correctly.

7.1 The Purpose of Commissioning:

- ♦ To confirm the correct designation of product versus application.
- ♦ To confirm the correct supply water conditions for the product / installation.
- ♦ To adjust the mixed temperature if necessary to suit the water supply conditions of the installation.
- ♦ To check the product is performing properly.
- ♦ To start an audit log and record appropriate data.

This product is factory set at 40 - 41°C with supplies of circa; 3 bar balanced pressure and temperatures of 17°C cold & 57°C hot (i.e. an inlet Δt of 40C° & a hot / mix Δt of 17C°)

For supply requirements, see 4.0 Water Supply Conditions.

7.2 Commissioning Process (see decision tree FC1)

- ♦ Establish that the supply conditions are within the requirements outlined above. If not investigate.
- ♦ When conditions are acceptable record them, together with hot and cold temperatures. Establish Δt .

Check the outlet mix temperature is within 41°C + / - 2°C, if not (*probably due to $\Delta t > 5C^\circ$ difference to factory setting*) adjust appropriately. (see 9.1)

- ♦ If mixed temperature is correct undertake an 'in field' cold water isolation (CWI) test: (see 7.5)
 - Pass – restore supply and record mixed temperature,
 - Fail – See 7.5 in-field 'Cold Water Isolation' test.

7.2 cont. Commissioning process (decision tree FC1)

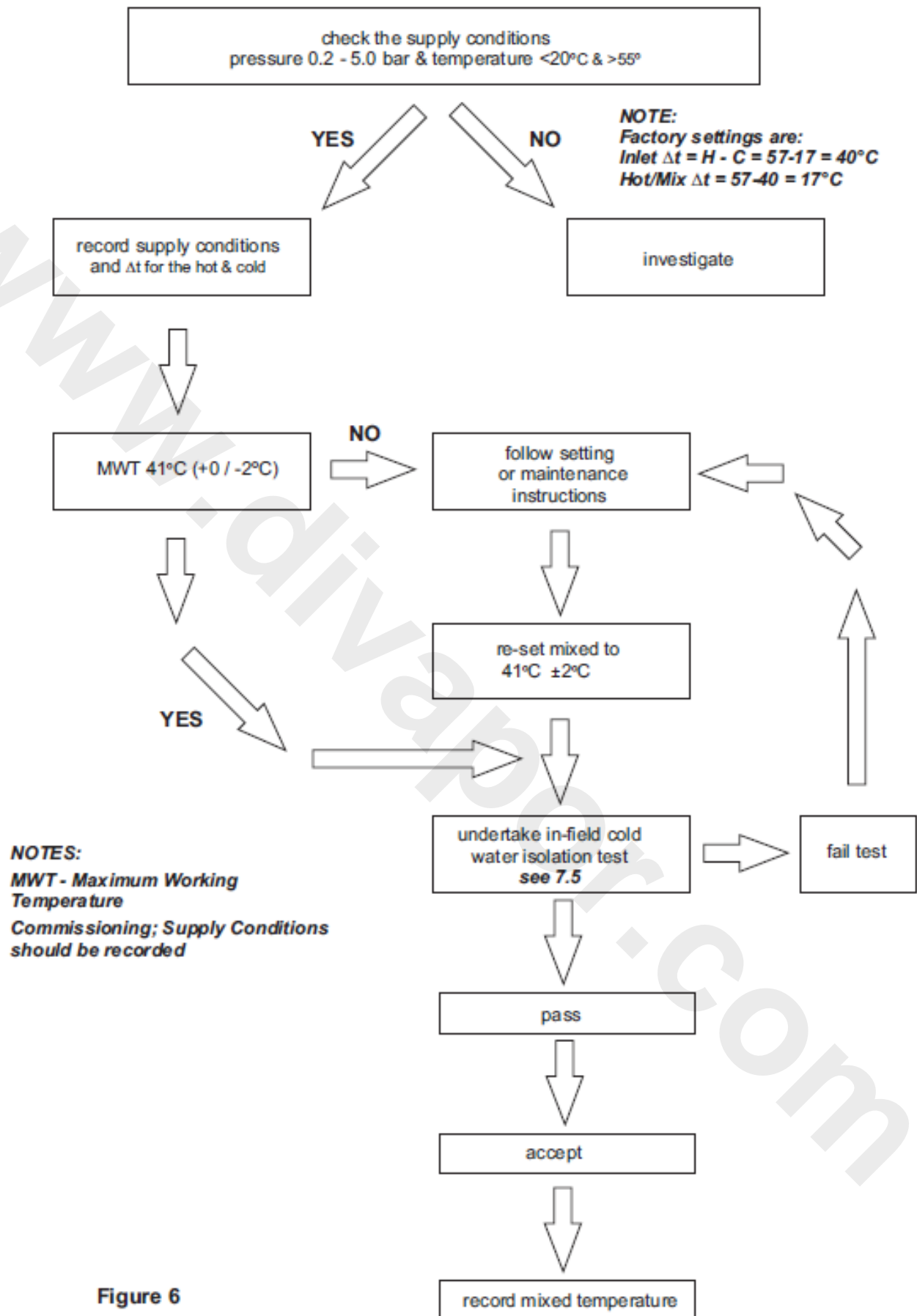

Figure 6

7.3 Audit Checks on TMV's

The purpose of a performance audit of a product is:

- ♦ To check the product continues to perform properly.
- ♦ To flag the need for the product to be adjusted due to supply condition changes or mechanism ageing.
- ♦ To ultimately identify the need for product maintenance.

Note - Additionally these audits facilitate regular verification of the supply conditions in accordance with HTM 04 requirements. (See decision tree FC3)

Audit of Supplies To Fittings (FC3)

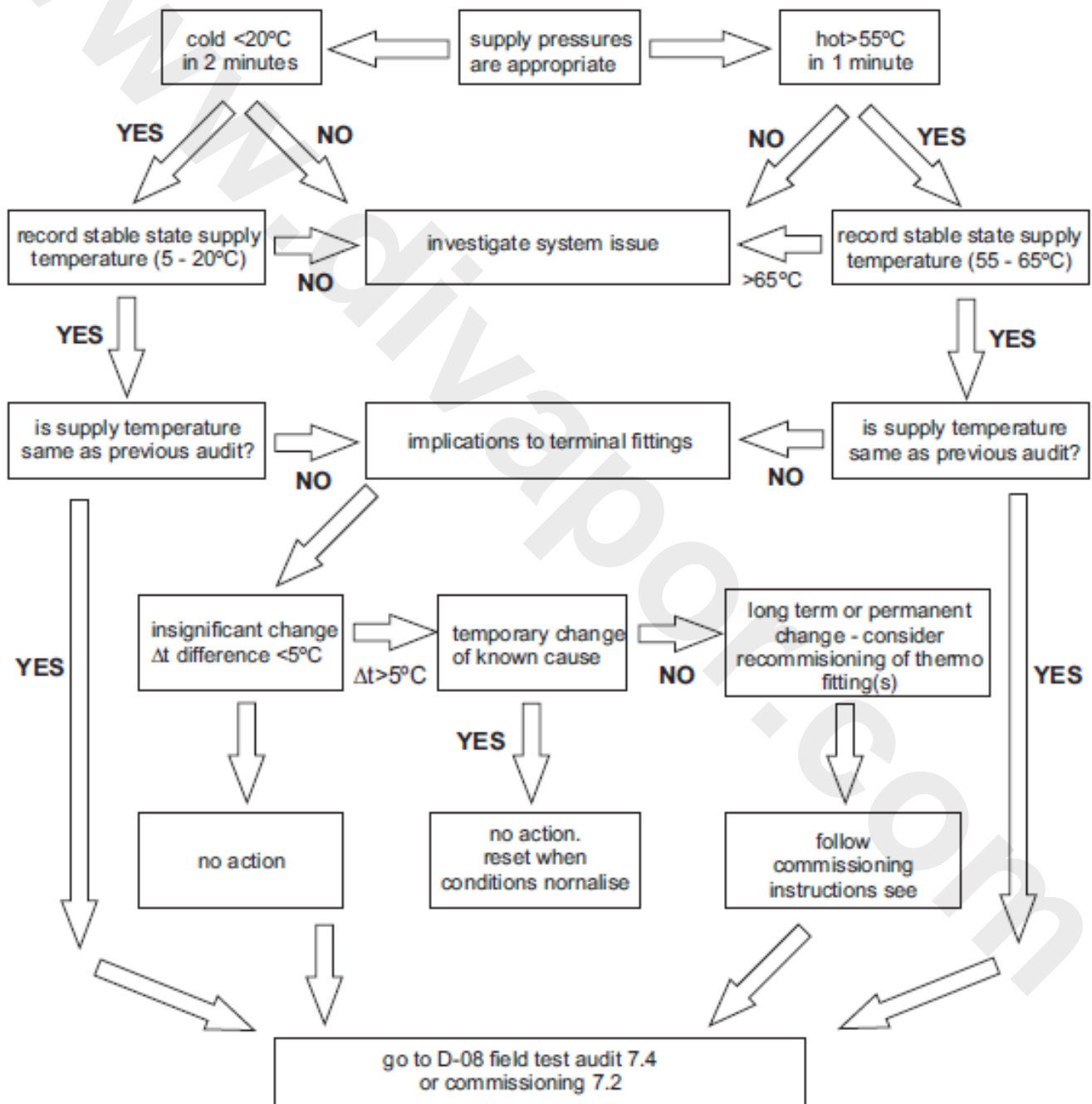

Figure 7

7.4 Audit procedure (see decision tree FC2)

- Verify the water supplies conditions are similar to when the product was commissioned i.e. inlet Δt as previous $\pm 5^\circ\text{C}$

Note: If inlet Δt change is $> 5^\circ\text{C}$ consider the cause of the change, If it is seen as a long term or permanent change, re-commission the product. If however, it is only a temporary change, retest when normal conditions resume.

- If inlet Δt differs from the commissioning Δt by $< 5^\circ\text{C}$ carry out field 'cold water isolation' (CWI) test as D-08: 2009. (see 7.5 in field **Cold Water Isolation test failure.**)
- Pass - restore the cold supply and move on to check the mix temperature.

Note: If the product fails CWI test, refer to 7.5 and then re-commission the valve.

- Mixed Temperature is as commissioned $\pm 2^\circ\text{C}$, Accept and record the temperature.

Note: If mixed Deviation $> \pm 2^\circ\text{C}$ (1st instance) reset mix as instructions and redo the test from start. See 9.1 Adjustment of the mix temperature.

- 2nd & subsequent instances follow maintenance instructions.

7.5 In-field 'Cold Water Isolation' (CWI) test.

Note: To gain access to the cold water isolating valve, unscrew the right hand shroud (13) & slide forward to expose the isolating screw on top of the cold inlet leg (see fig.12, section 10).

Using a flat-blade screw driver, the screw can be rotated 90° in either direction to isolate the cold water supply.

Before commencing the CWI test, ensure:

1. The water supply conditions are met either:
 - A. For commissioning a new product (see table 1, section 4).
 - B. Or the inlet Δt is within $\pm 5^\circ\text{C}$ to when the product was commissioned (see 7.4).

NOTE It is important that the hot temperature is greater than 55°C

2. Mixed water outlet temperature is correct (see table 2, section 8).

Fitting Field Test Audit (FC2)

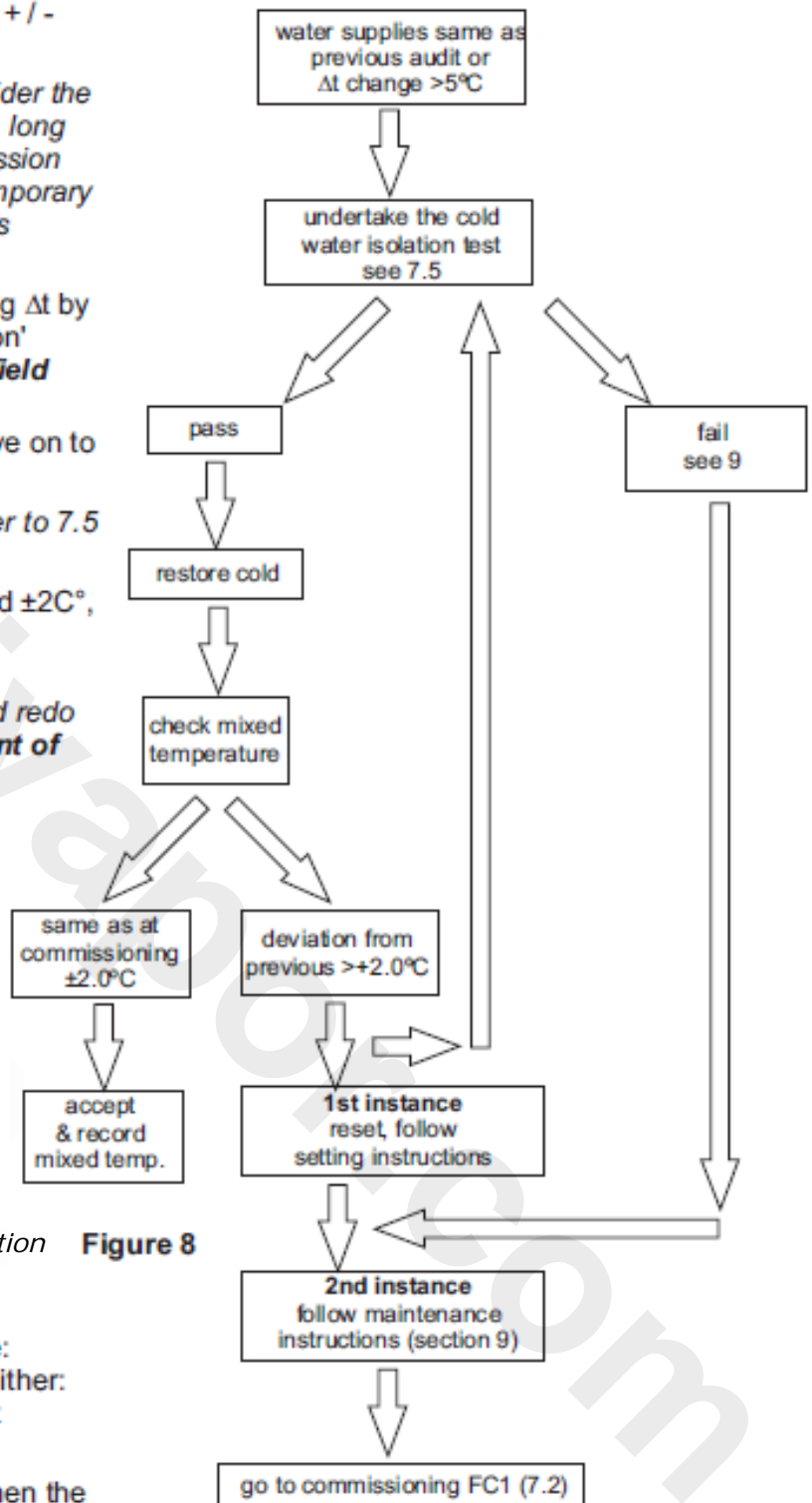

Figure 8

To perform a CWI test, operate the product by rotating the lever fully to the right.

Then conduct the following procedure:

1. Record the steady state temperature of both hot and cold water supplies. Note the Δ .
2. Record the temperature of the mixed water at the outlet.
3. Isolate the cold water supply (by rotating the isolating screw 90° & monitor the flow of water from the outlet).

If the flow ceases, CWI test passed:

1. Restore the cold water supply by rotating the isolator screw 90°
2. Slide the shroud back & screw *towards the wall*.
3. Re-check the temperature of the stabilised mixed water at the outlet to ensure it is still correct.

Accept & record mixed temperature.

If there is an ongoing flow of water from the mixed water outlet, then 5 seconds after CWI collect the discharging water into a measuring vessel for 60 seconds. To pass the CWI test the volume of collected water should be less than 120ml.

If the product fails CWI test, see FC2 (*see section 7*). Follow product maintenance (*see section 9*) and servicing (*see section 8*) instructions.

8 SERVICING - TVM3 SCHEME

The need for servicing is normally identified as a result of the regular performance auditing.

Application	Maximum mixed water temperature during normal operation	Permitted maximum temperature rise recorded during site testing
Washbasin	41°C	43°C

Table 2 A guide to maximum temperature sets

8.1 FREQUENCY OF REGULAR SERVICING

The purpose of servicing regularly is to monitor any changes in performance due to changes in either the system or the product. This may highlight the need to adjust either the supply system or the product. These products should be audited 6 to 8 weeks and again 12 to 15 weeks after commissioning. The results are to be compared against original commissioning settings.

If there are no significant changes at the mixed temperature outlet then a 6 monthly servicing cycle may be adopted. Otherwise, servicing checks should be carried out more frequently (e.g. every 4 months).

Follow the recommended auditing and maintenance procedures detailed in sections 7 & 9.

During servicing, note the following:

1. Repeat the procedure of recording and checking supply temperatures. (The same type of measuring equipment should be used)
2. If the temperature has changed significantly from the previously recorded values, the following should be checked:
 - a. All in-line or integral valve filters are clear of obstruction.
 - b. All in-line or integral check valves are clean and working properly to prevent backflow.
 - c. Any isolating valves are fully open.
 - d. The thermostat is free of debris
3. When satisfied with the mixed outlet temperatures re-record the temperatures.

9 MAINTENANCE

When installed as a TMV3 application it is a requirement that the commissioning and maintenance procedures, detailed under 7 & 8, be carried out.

9.1 Adjustment of the mix temperature:

♦ **Note: Cartridge is factory pre-set at 40 - 41°C.**

1. Move the lever to the fully on (max) position.
2. Remove the lever by prising out the cover button and unscrewing the retaining screw using a 4mm Allen key. *See fig.10*
3. Remove the upper Anti clockwise stop ring (slide off spindle).
4. Rotate spindle (using lever handle) to achieve correct mix temperature. (40 - 41°C) Rotate clockwise to reduce and anti-clockwise to increase
5. Refit the upper stop ring against cartridge stop face.

Note:1. This is the normal maximum temperature range for the product and as such there is a wide zone of spindle movement that gives this mix temperature. For best performance you should refit the stop at the first point of anticlockwise rotation that achieves the desired setting.

Note:2. If you are unable to achieve 40 - 41°C Max and you have the correct Δt 's it may be due to fine debris.

See 9.2 Removal and inspection of cartridge.

6. Upon successful completion of the temperature adjustment, conduct the **Cold Water Isolation (CWI) test (See 7.5)** to ensure product is working properly.
7. Refit the lever and record the mix temperature.

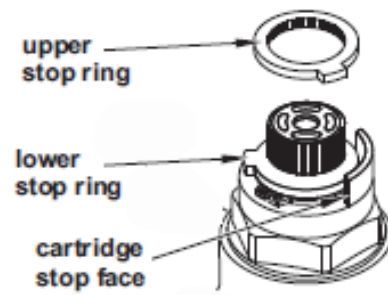

Figure 9
Adjusting the pre-set temperature

9.2 Removal and inspection of cartridge

After checking that supply conditions are within the specified parameters (see table 1), if the fitting malfunctions or should the test results fail to fall within the specified limits consider replacing the cartridge with a new one. **See 9.3 Important notes on debris.**

Isolate the fitting by turning the isolating valves 90° *in either direction, see fig.10.*

Remove the lever handle as described in 9.1. Unscrew the cartridge from the body with a 36mm a/f deep socket. Inspect cartridge for damage.

Replace cartridge if necessary and reassemble cartridge into body.

The replacement cartridge should be tightened to a torque of 15Nm. (To re-secure the cartridge we recommend the use of Permabond A011 or equivalent applied to the thread of the cartridge)

Replace lever handle and reinstate the supplies.

After fitting the new cartridge start the test procedure from the section on commissioning.

- ♦ Redo the Cold Water Isolation (CWI) test (**See 7.5**).
- ♦ Once satisfied with the CWI test, re-check and if necessary, adjust the maximum mix temperature, see (**See 9.1**).
- ♦ Record the mix temperature.

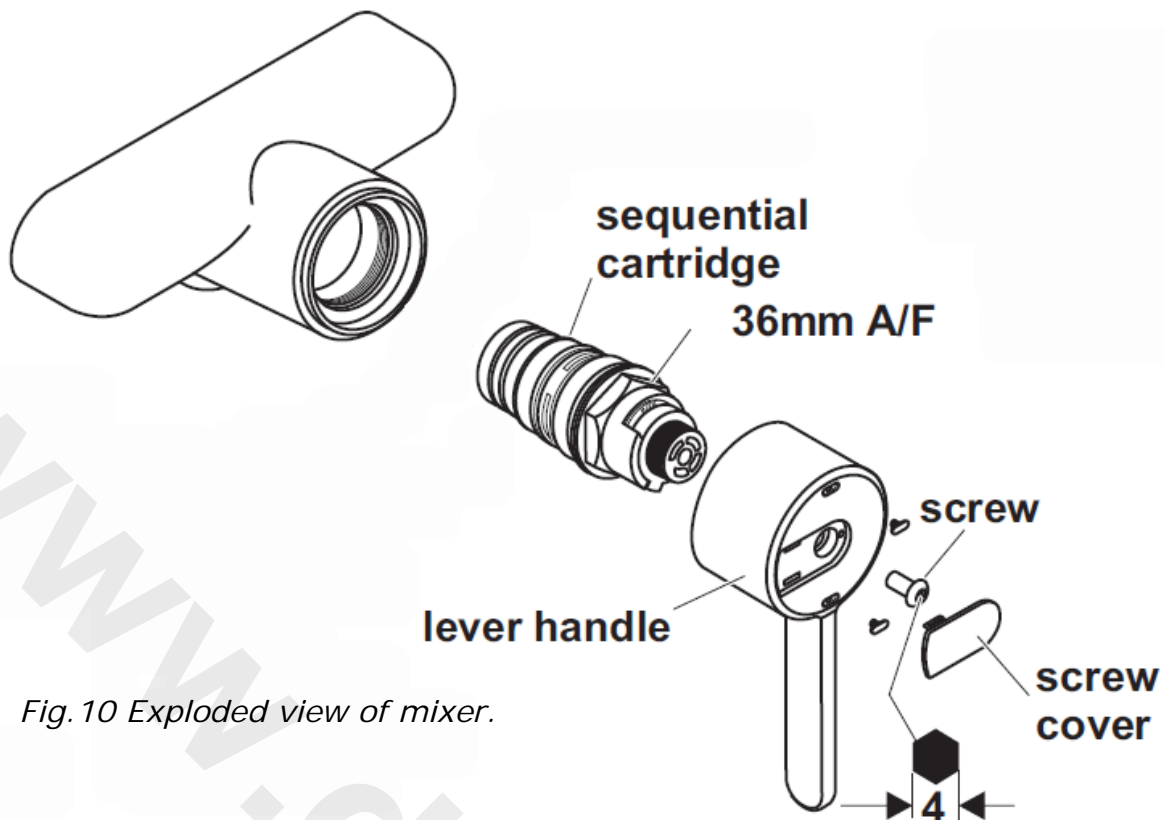

Fig. 10 Exploded view of mixer.

9.3 Important notes on debris:

Although this product is protected by built-in filters, debris can still find its way to the thermostat housing area. This can happen during servicing for example. Remove cartridge (see section 9.2) and carry out an inspection.

9.4 Thermostatic Cartridge Ageing:

Following many years of normal service you may notice the following:

1. The need to carry out more frequent adjustment of mixed temperature.
2. The thermostatic element may not pass the CWI test.

These issues could be due to the ageing of the thermostat which loses some expansion capability over time.

These are the principle objectives of testing, as they serve to indicate to maintenance staff the declining performance capability of the thermostatic cartridge.

For this reason the audit testing flow chart highlights that 2nd Instance CWI test failure or 2nd instance mixed deviation even with stable 'as commissioned' supply conditions and correct inlet supply Δt 's, is potentially the first indication of the need to replace the cartridge.

9.5 Maintenance cleaning

On a regular basis *the shower spray head should be inspected &* cleaned if necessary. This should be done immediately before sterilising is carried out.

In areas where lime scale build-up is prevalent this will have to be removed. An inhibited proprietary scale solvent can be used such a kettle descaling solvent but it is important to follow the manufacturer's guidelines. After descaling it is important to rinse the parts thoroughly in clean water. Clean carefully and do not use abrasive materials or scrapers.

10 ISOLATING VALVES

Isolation valves facilitate 4 activities:
1) Cleaning strainers & check valves
3) Disinfection

2) Servicing the cartridge
4) Audit cold water isolation test

Strainers

To ensure trouble free operation of the fitting, the strainer elements should be checked and cleaned in accordance with the commissioning and servicing guide. (see section 8)

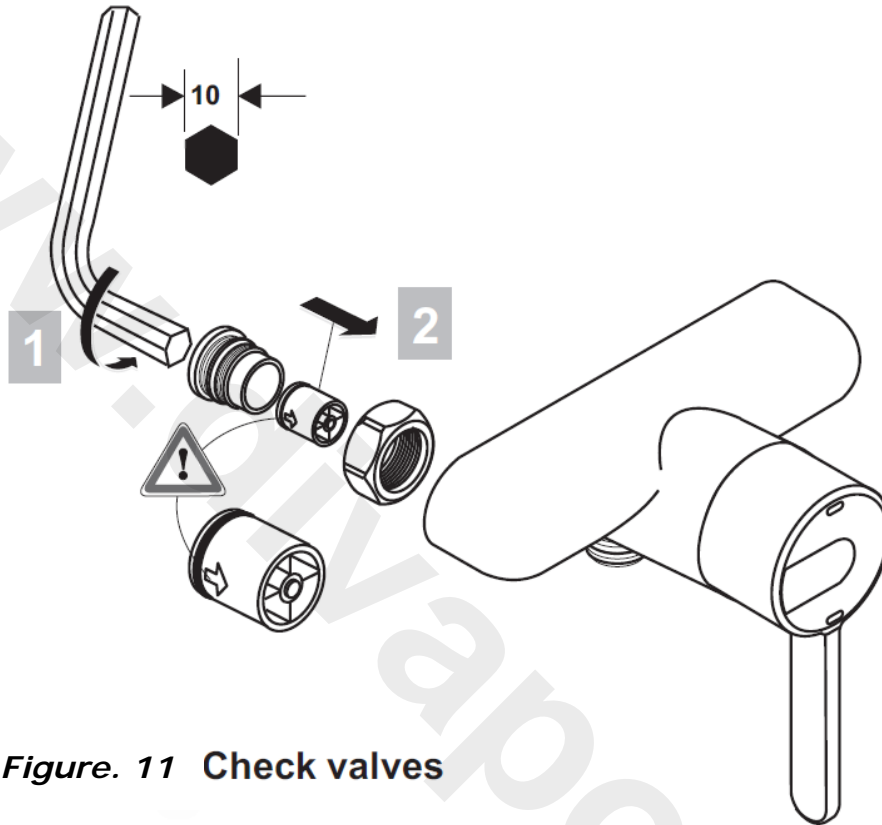

Figure. 11 Check valves

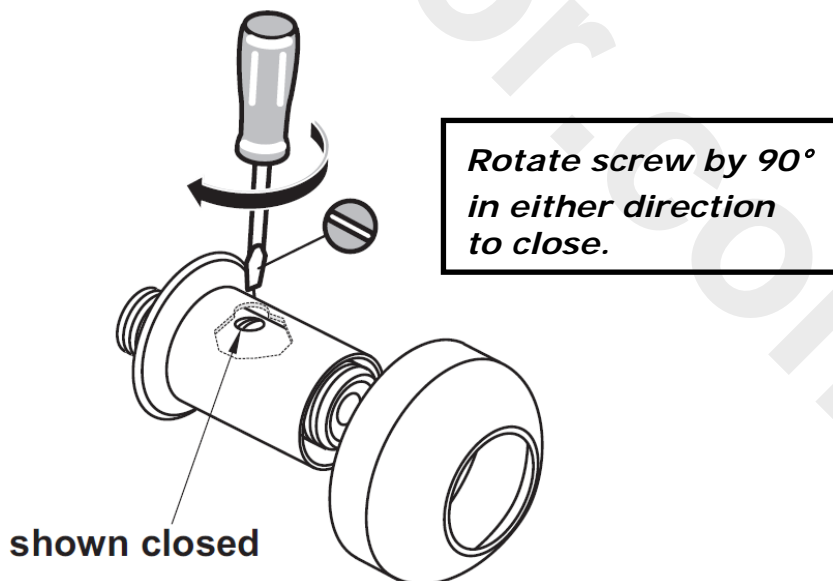

Figure. 12 Operation of isolating valves shown closed

11 SPARE PARTS

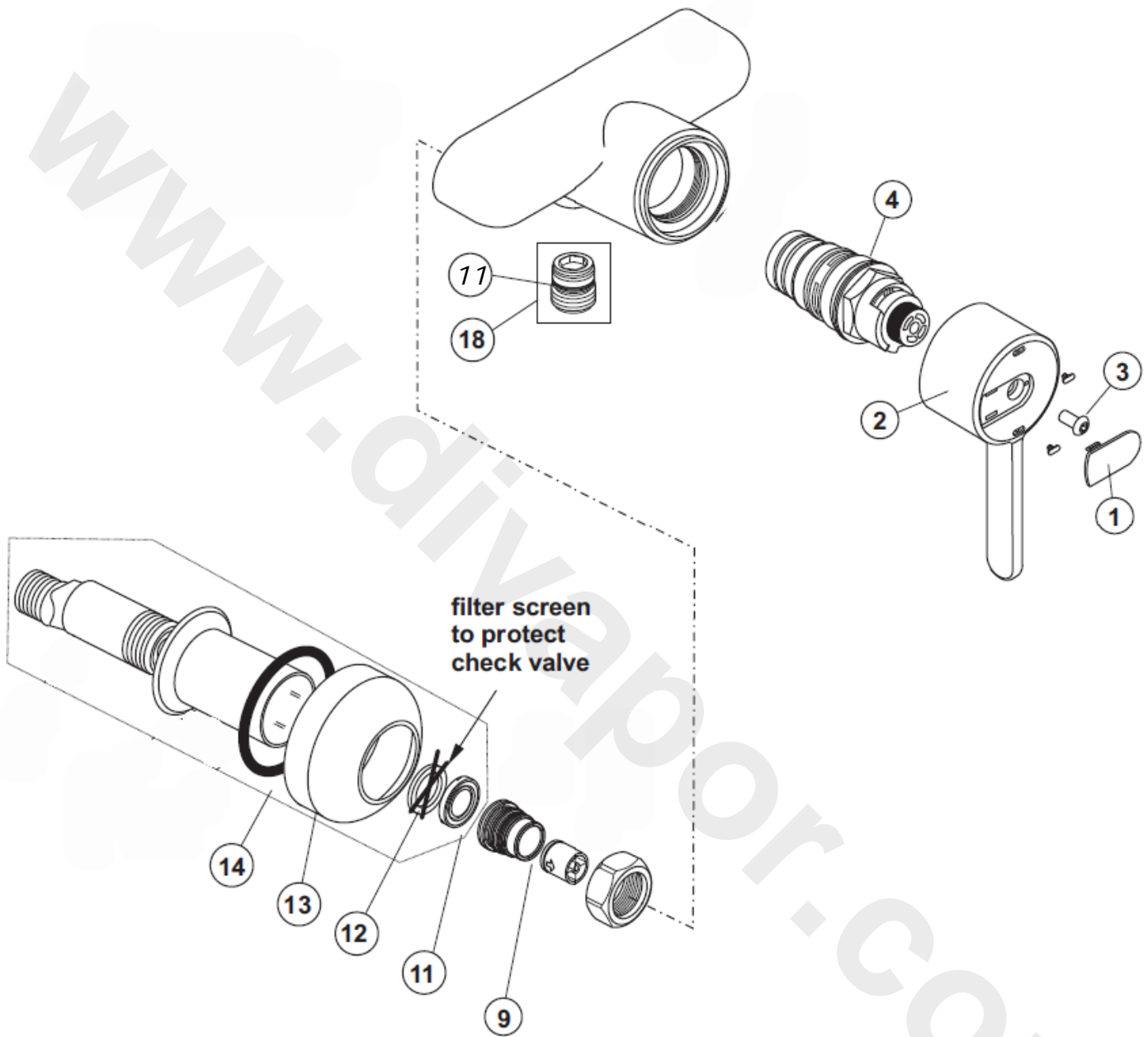

Fig.13 Exploded view of mixer, showing spares.

11 SPARE PARTS - continued from page 14

Ref.	Description	Part No.
1	Cover cap, non-res, AS logo	A962 017AA
2	Lever handle kit complete	A961 456AA
3	Handle retaining screw	A961 950NU
4	Thermostatic cartridge	A962 280NU
9	Non-return valve (single)	A860 415NU
11	O-ring (pair) inlet bolt & outlet	A961 810NU
12	Filter insert (pair)	A961 892NU
13	Escutcheon (single)	A960 599AA
14	S-connector & trim kit complete	A961 893AA
18	Outlet nipple & o-ring	A963 651NU

www.divaport.com

After Sales Non Residential Telephone:

0870 122 8822

After Sales Non Residential Fax:

0870 122 8282

E-mail:

aftersalesnonresidential@idealstandard.com

Armitage Shanks pursues a policy of continuing improvement in design and performance of its products.

The right is therefore reserved to vary specification without notice.

**Armitage Shanks,
Armitage, Rugeley, Staffordshire, WS15 4BT.
www.thebluebook.co.uk**

A866449 05/11

ARMITAGE NPD