

*Armitage
Shanks*

**Contour 21 sequential thermostatic
lever operated shower mixer**

**INSTALLATION
INSTRUCTIONS**



A4129AA

**Contour 21 sequential thermostatic lever
operated build-in shower mixer**

IMPORTANT
BEFORE CONNECTION, FLUSH WATER THROUGH PIPEWORK TO REMOVE
ALL DEBRIS ETC. WHICH COULD DAMAGE THE VALVE MECHANISM

INSTALLER: After installation please pass this instruction booklet to user

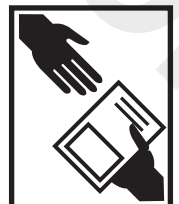

TABLE OF CONTENT

1	CONTENTS	2
2	DESCRIPTION.....	3
3	PRODUCT BOX CONTENTS	3
3.1	DIMENSIONS	4
4	WATER SUPPLY CONDITIONS	5
4.0	WATER REGULATIONS.....	5
4.1	INTRODUCTION	5
4.2	SUPPLY PRESSURE OVERVIEW	5
4.3	HEALTHCARE ESTABLISHMENTS.....	5
5	INSTALLATION GUIDE.....	6
5.1	FITTING TRIM KIT	8
5.2	HANDLE FIXATION	9
6	OPERATION	9
7	COMMISSIONING AND AUDITS.....	10
7.1	PURPOSE OF COMMISSIONING	10
7.2	COMMISSIONING PROCESS	10
7.3	AUDIT CHECKS ON TMV'S.....	12
7.4	AUDIT PROCEDURE	13
7.5	IN-FIELD 'COLD WATER ISOLATION' (CWI) TEST.....	13
8	SERVICING.....	14
8.1	FREQUENCY OF REGULAR SERVICING	14
9	MAINTENANCE	15
9.1	ADJUSTMENT OF THE MIX TEMPERATURE	15
9.2	REMOVAL AND INSPECTION OF CARTRIDGE	16
9.3	IMPORTANT NOTES ON DEBRIS.....	17
9.4	THERMOSTATIC CARTRIDGE AGEING	17
10	INLINE SERVICE VALVES	17
11	INTEGRAL COMBINED CHECK VALVES & FLOW REGULATORS	18
12	SPARE PARTS.....	19
13	CLEANING CHROME SURFACES	20

2 DESCRIPTION



A4129AA Contour 21 sequential thermostatic lever operated built-in shower mixer.

This product is suitable for healthcare Installation and is delivered ready to be installed directly into a cavity or directly on to pre-made frame work in solid brick walls, panels or GRP pod constructions.

This manual covers the A4129AA Contour 21 sequential, thermostatically controlled, lever operated, built-in shower mixer. It is designed to provide water from ambient cold up to a safe maximum temperature for showering.

It comes complete with integral combined check valves & 5 lpm flow regulators. A pair of in-line service valves with strainers are supplied to permit isolation of product for maintenance.

Mixer is factory set to deliver water at $40 \pm 1^\circ\text{C}$ at 3 bar.

3 PRODUCT BOX CONTENTS

Fig.3a Kit-1 or "rough"

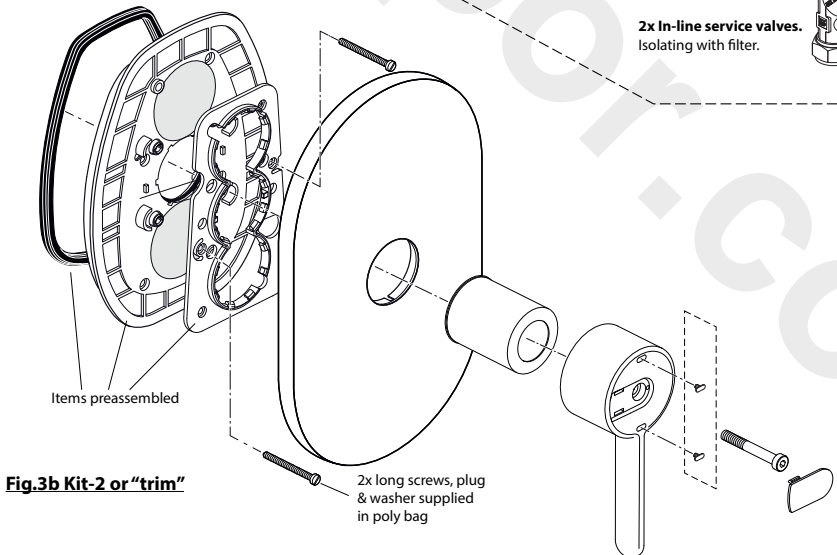
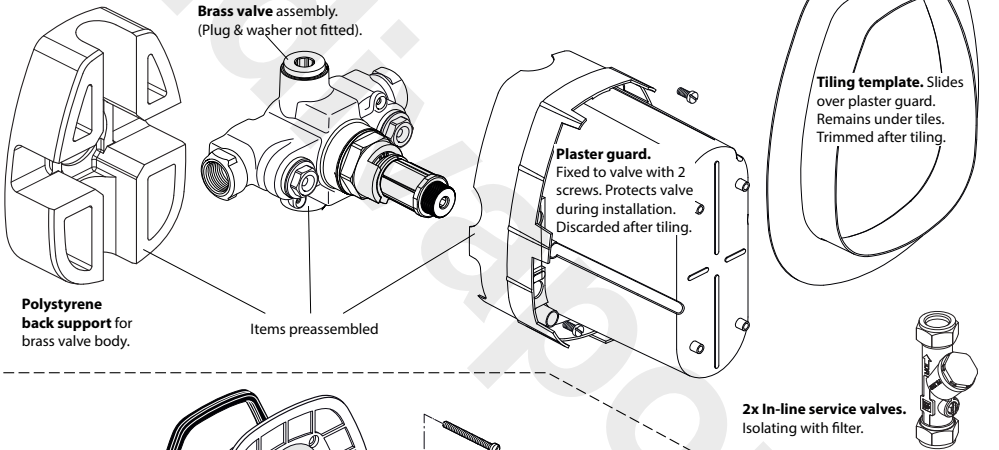

3.1 Dimensions

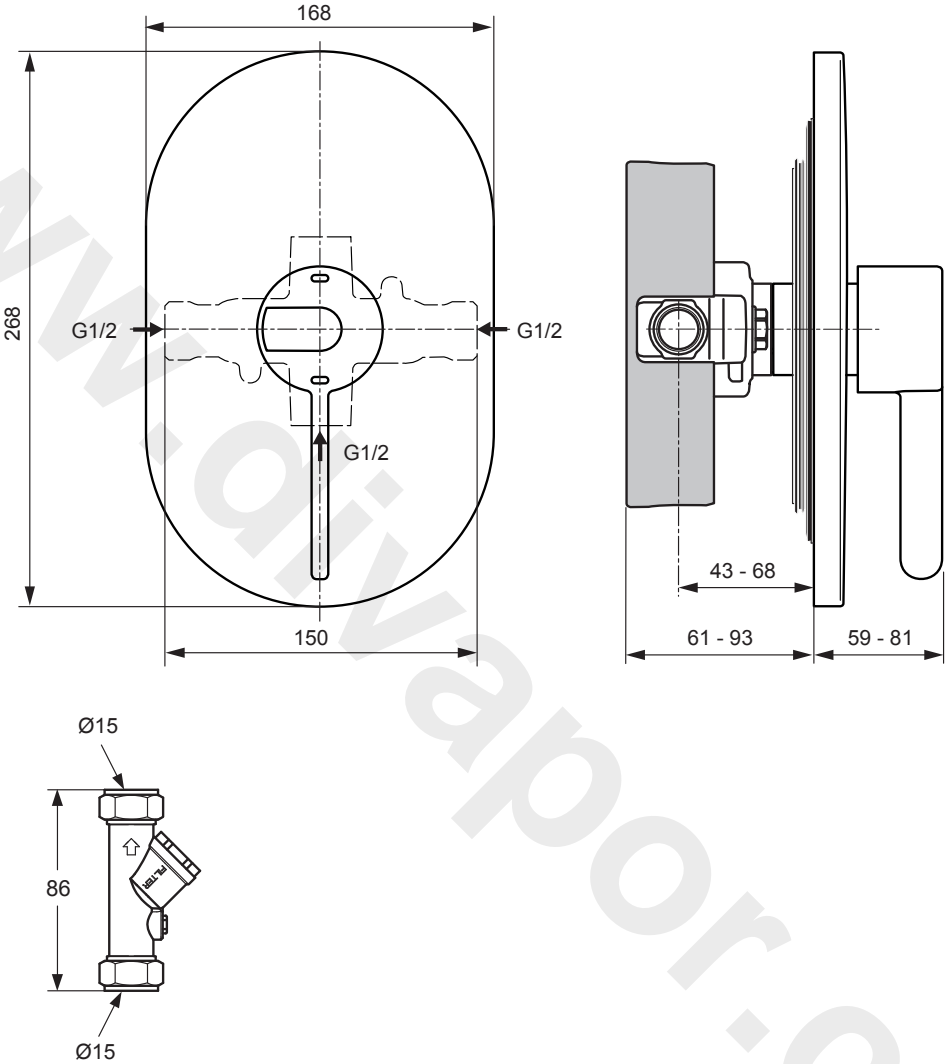

Fig. 3c Product dimensions

IMPORTANT: Prior to installing mixer, ensure that any existing thermostatic mixing valves (TMVs) that may be fitted are removed

4 WATER SUPPLY CONDITIONS

4.0 Water regulations

The fittings covered by this installation and maintenance instruction should be installed in accordance with the water regulations published in 1999*, therefore Armitage Shanks would strongly recommend that these fittings are installed by a professional installer

*A guide to the Water Supply (Water Fittings) Regulations 1999 and the Water Byelaws 2000, Scotland is published by WRAS (Water Regulations Advisory Scheme) Unit 13, Willow Road, Pen-y-Fan Industrial Estate, Crumlin, Gwent, NP11 4EG. ISBN 0-9539708-0-9

4.1 Introduction

This sequential thermostatic lever operated mixer is manufactured to the highest standards and have approval to TMV3 which permits it to be installed in healthcare establishments such as hospitals, nursing homes and residential care homes. When installed in healthcare establishments the supply conditions detailed in Table 1 must be observed and the commissioning and servicing requirements detailed on section 7 & 8 must be followed.

For other installations this is not a requirement.

4.2 Supply Pressure Overview

This mixer is designed to be installed on all types of plumbing systems.

Hot and cold water supply pressures should be reasonably balanced, however, the mixer will function within specification on unequal pressures up to 5 :1.

Mixer comes complete with integral combined check valves & 5 lpm flow regulators. A pair of in-line service valves with strainers are supplied to permit isolation of the product for maintenance.

The service valves should be installed in an easily accessible location. The minimum pressure for the correct thermal operation is 0.2 bar. However, in order to achieve an acceptable flow performance at very low pressures it may be necessary to replace the flow regulated check valves (14a) with simple check valves (14b). See section 11 & 12.

IMPORTANT: DO NOT REMOVE check valves completely.

4.3 Healthcare Establishments

In accordance with the NHS model engineering specifications DO8 this valve has approval for the following applications:-

High Pressure	HP-	-	S
Low Pressure	LP-	-	SE

For this type of application the following supply conditions must apply:

Operating pressure range:	High Pressure	Low Pressure
Maximum static pressure	10 bar	10 bar
Flow pressure hot and cold	1 to 5.0 bar	0.2 to 1.0 bar
Hot supply temperature	55 to 65 °C	55 to 65 °C
Cold supply temperature	5 to 20 °C	5 to 20 °C

Note:

Fittings operating outside these conditions cannot be guaranteed by the scheme to operate as **TMV3**.

Table 1 Supply conditions for healthcare establishments

Effectively this means:

Differential between HOT and COLD inlet temperatures (Δt) must be 35°C min and 60°C max

Differential between HOT inlet temperature and MIXED temperature (Δt) > 14C° preferred

See 7.3 Audit checks on TMV's.

5 INSTALLATION GUIDE



Before connection, flush water through pipe-work to remove all debris etc. to prevent damage to the valve mechanism.

THEN ENSURE WATER SUPPLIES HAVE BEEN ISOLATED.

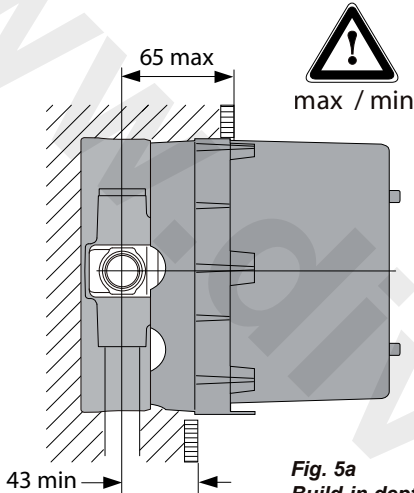

Fig. 5a
Build-in depths

Mounting location

Decide on a suitable location for mounting the mixing valve on the wall. Give consideration to the mounting depth as shown here.

The plaster guard (blue moulding) is marked at the top end with MINIMUM & MAXIMUM to help the installer achieve the correct depth. The dimensions are shown from the centre line of the outlet pipe to the finished surface (which could be tiles).

The back support (white polystyrene moulding) can be left in position to support the brass valve & act as a levelling guide. Use a spirit level for accuracy.

The profile of either the back support or the large side of the plaster guard can be used as a guide for marking out the size & shape of the aperture required in the finished wall for the sealing the trim kit.

1. All 4 ports on this valve are threaded 1/2" female.

Inlet ports

The HOT water supply to the valve should be on the left & COLD water supply on the right.

Outlet ports

The valve has two outlet ports. The installer can decide which port to use & fit the supplied 1/2" plug into the other port.

Purchase 3x 1/2" male connectors suitable for the type of pipe being used to plumb the installation. Use an appropriate approved thread sealing medium.

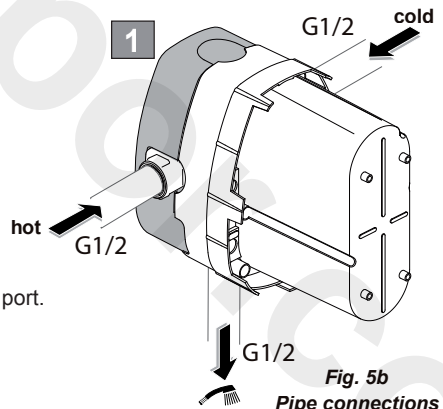

Fig. 5b
Pipe connections

NOTE FOR IRELAND: 15mm olives are supplied with this product. Use 1/2" olives if 1/2" supply pipes are fitted.



DO NOT apply heat near this product. Heat generated by soldering could damage plastic parts and seals.

In-line service valves

IMPORTANT: The inline service valves supplied with this product must be fitted into the pipe-work. See section 10 for more details.

Consider a suitable location for the service valves. During installation, the service valve can be held with grips or use an adjustable spanner on the flats of the valve body.

Orientate the service valve such that the filter cap & isolating screw are easily accessible for future maintenance.

Fit pipes to both sides of the service valves & make good the all the joints.

NOTE: When the isolator screw slot is parallel to the valve body, the valve is open & permits water to flow. To close the valve, rotate the isolator screw 90°. Valves can be left closed until after the trim kit has been fitted.

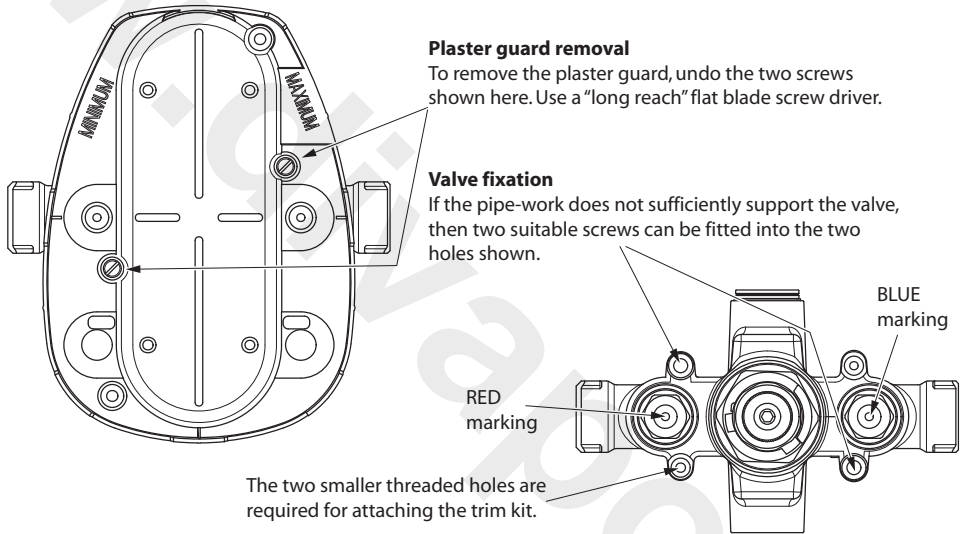

Fig. 5c Valve markings & mounting holes

Blanking plug

A ½" blanking plug is supplied with a copper sealing washer. Blank off the outlet port not being used. Above, the top port is shown with the plug fitted. With the seal in place, use a 10mm hexagonal key to tighten plug into the port being blanked.

Check valve housings

The top surfaces of the check valve housings are marked RED on the left side & BLUE on the right side. The markings signify the HOT & COLD water supply sides respectfully.

NOTE: If hot & cold water supplies are mistakenly plumbed incorrectly, the two check valve housings can be swapped to correct this issue.

With the valve secured, pipe-work attached, & blanking plug fitted, the plaster guard can be reattached to the valve to protect it from subsequent decorating tasks.

Make good the wall up to the profile of the plaster guard.

Check that all joints are securely tightened, test for leaks.

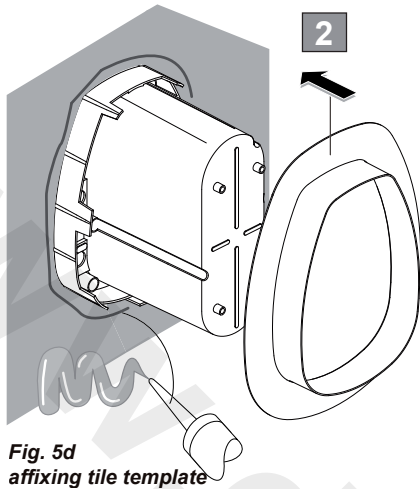

Fig. 5d
affixing tile template

Tiling

2. If the finished wall is to be tiled, then the tiling template should be used. Apply a thin layer of silicon sealant on the wall surrounding the plaster guard as shown. Slide the tiling template over the plaster guard & press it firmly against the wall. Wipe away any excess silicone. Allow silicone time to set.

3. Affix tiles to wall & trim neatly - close to the tiling template.

4. Undo the two screws shown here. Use a "long reach" flat blade screw driver.

5. To remove the plaster guard gently pull it away from the wall. The plaster guard & the two small screws can be discarded.

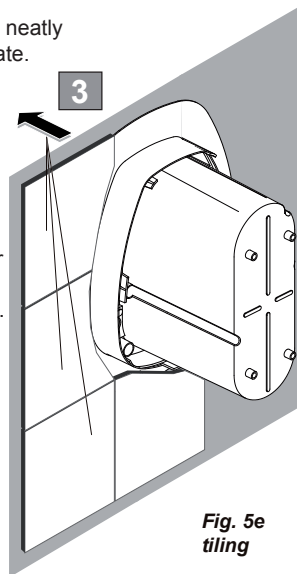

Fig. 5e
tiling

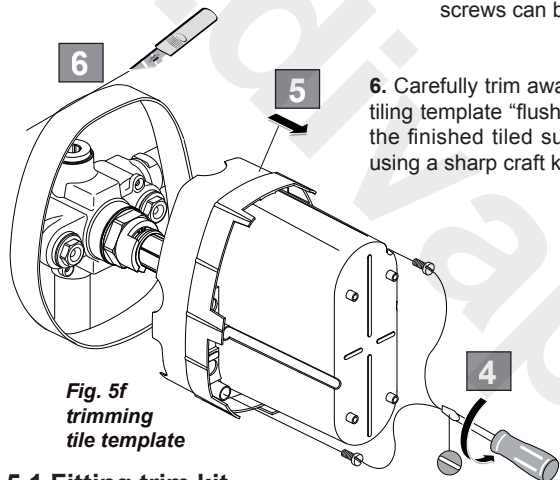

Fig. 5f
trimming
tile template

6. Carefully trim away the tiling template "flush" with the finished tiled surface using a sharp craft knife.

5.1 Fitting trim kit

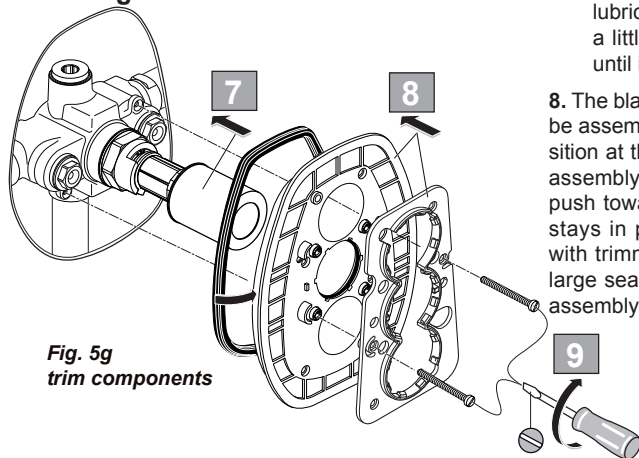

Fig. 5g
trim components

7. Carefully slide the chrome shroud onto the central cartridge boss. If necessary lubricate the o-ring with water containing a little washing-up liquid. Press shroud until it bottoms out on the shoulder.

8. The black mouldings shown should already be assembled. Ensure the large seal is in position at the rear. Align the centre hole of the assembly with the chromed shroud & gently push towards the wall. Ensure centre o-ring stays in position. Next align this assembly with trimmed tiling template. Manipulate the large seal into the tiling template. Press this assembly against the finished tiled wall.

9. Fit the long screws supplied into the holes as shown. Tighten screws using a flat blade screw driver.

10. Align the hole in the chromed escutcheon plate to the projecting chromed shroud & carefully press it against the finished wall.

11 to 13 see below.

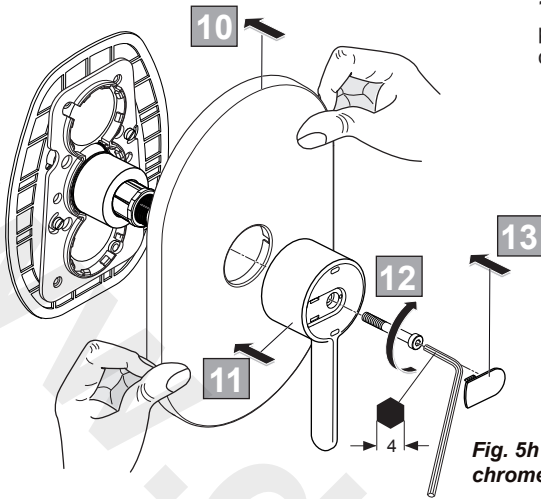

Fig. 5h
chrome trim components

5.2 Handle fixation

NOTE: Handle screw is already fitted to the grey spindle-extension on the shower valve. Undo this screw using a 4mm hexagonal key. Ensure spindle-extension remains seated on the thermostatic cartridge.

Fit the handle as follows:

Rotate the spindle-extension fully clockwise until it stops (excessive force is not required). Handle spline can be engaged onto spindle to assist rotation if necessary. The spindle is now in the "off" position.

11. Orientate the handle as shown above & locate it onto the spindle.

12. Locate fixing screw into the centre of the handle & tighten.

13. Finally snap the index button into the handle.

OPEN THE ISOLATING VALVES & CHECK FOR WATER FLOW.

6 OPERATION

Fig.6 showing the handle control positions.

As the handle is rotated anticlockwise from the off position the delivered water progresses from cold through warm to the preset maximum temperature of approximately 41°C.

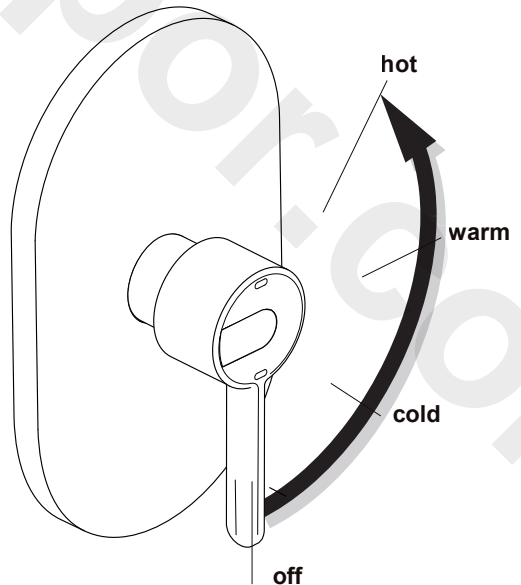

7 COMMISSIONING AND AUDITS

The following procedure should be conducted after installation to ensure the product is functioning correctly.

7.1 Purpose of commissioning

- To confirm the correct designation of product versus application.
- To confirm the correct supply water conditions for the product / installation.
- To adjust the mixed temperature if necessary to suit the water supply conditions of the installation.
- To check the product is performing properly.
- To start an audit log and record appropriate data.

This product is factory set at $40 \pm 1^{\circ}\text{C}$ with supplies of circa; 3 bar balanced pressure and temperatures of 15°C cold & 65°C hot (i.e. an inlet Δt of 50°C & a hot / mix Δt of 24°C)

For supply requirements, see 4.0 Water Supply Conditions.

7.2 Commissioning Process (see decision tree FC1)

- Establish that the supply conditions are within the requirements outlined above. If not investigate.
- When conditions are acceptable record them, together with hot and cold temperatures. Establish Δt .

Check the outlet mix temperature is within $40 \pm 2^{\circ}\text{C}$, if not (probably due to $\Delta t > 5^{\circ}\text{C}$ difference to factory setting) adjust appropriately. (see 9.1)

- If mixed temperature is correct undertake an 'in field' cold water isolation (CWI) test: (see 7.5)

Pass – restore supply and record mixed temperature,

Fail – See 7.5 *in-field 'Cold Water Isolation' test.*



For more information on spare parts why not visit our spare website:
www.fastpart-spare.co.uk. Or contact customer care

7.2 cont. Commissioning process (decision tree FC1)

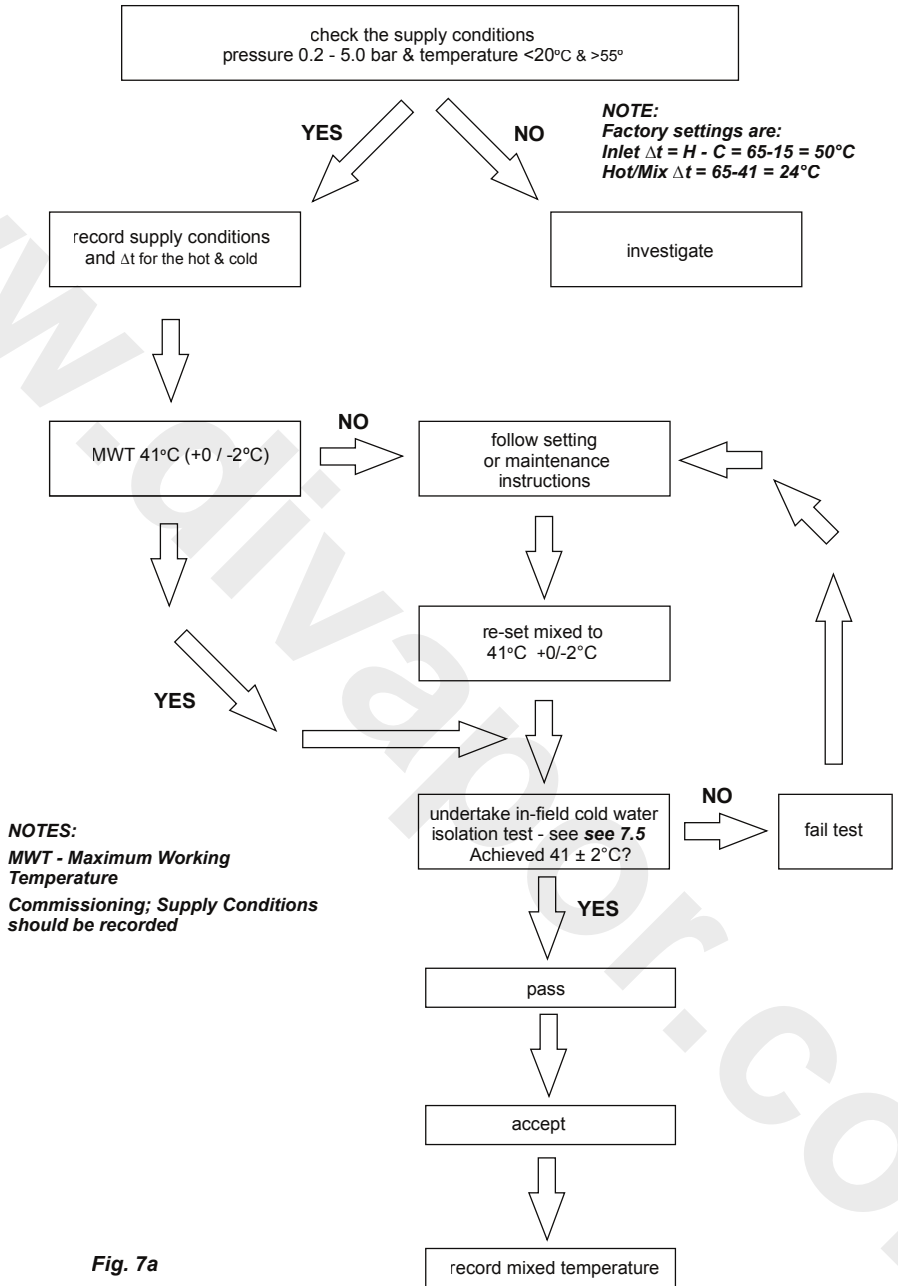

Fig. 7a

7.3 Audit Checks on TMV's

The purpose of a performance audit of a product is:

- ♦ To check the product continues to perform properly.
- ♦ To flag the need for the product to be adjusted due to supply condition changes or mechanism ageing.
- ♦ To ultimately identify the need for product maintenance.

Note - Additionally these audits facilitate regular verification of the supply conditions in accordance with section 4.3 requirements. (See decision tree FC3)

Audit of Supplies To Fittings (FC3)

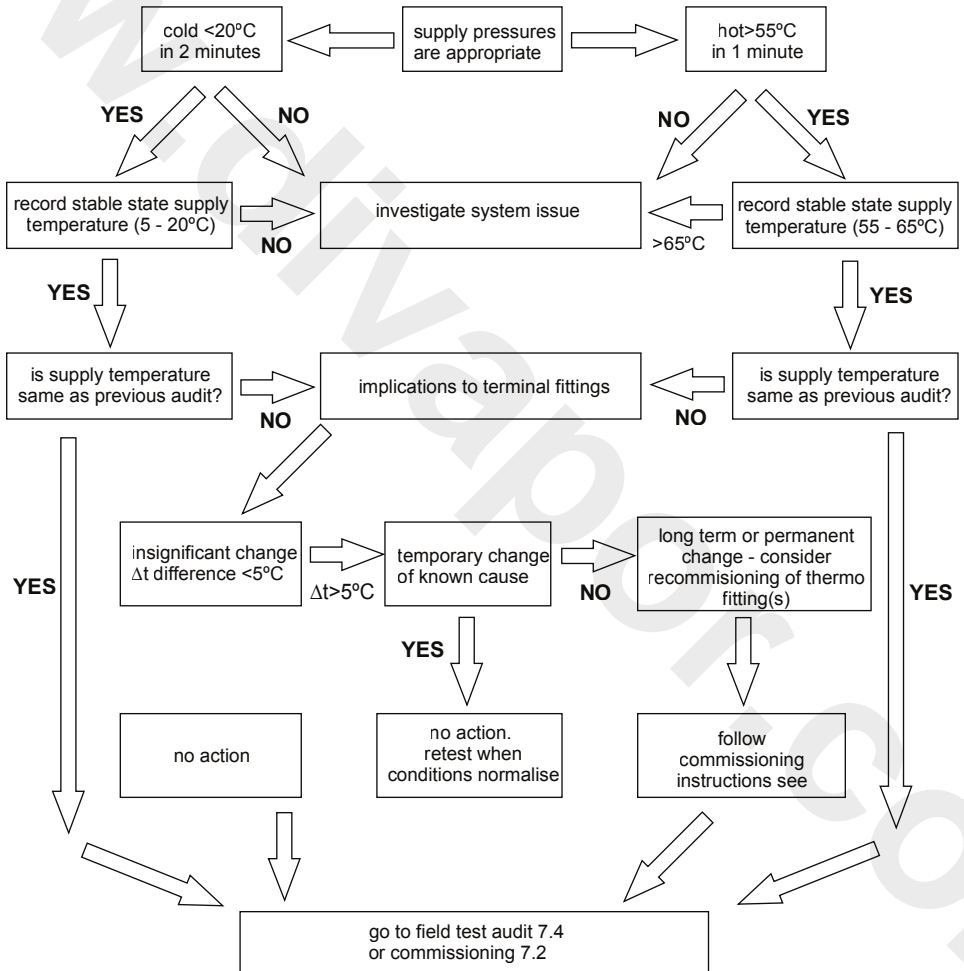

Figure 7b

7.4 Audit procedure (see decision tree FC2)

- Verify the water supplies conditions are similar to when the product was commissioned i.e. inlet Δt as previous + / - 5C°

Note: If inlet Δt change is > 5C° consider the cause of the change, If it is seen as a long term or permanent change, re-commission the product. If however, it is only a temporary change, retest when normal conditions resume.

- If inlet Δt differs from the commissioning Δt by < 5C° carry out field 'cold water isolation' (CWI) test (see 7.5 in field **Cold Water Isolation test failure**).
- Pass - restore the cold supply and move on to check the mix temperature.

Note: If the product fails CWI test, refer to 7.5 and then re-commission the valve.

- Mixed Temperature is as commissioned $\pm 2C^\circ$, Accept and record the temperature.

Note: If mixed Deviation > $\pm 2C^\circ$ (1st instance) reset mix as instructions and redo the test from start. See 9.1 Adjustment of the mix temperature.

- 2nd & subsequent instances follow maintenance instructions.

7.5 In-field 'Cold Water Isolation' (CWI) test.

Locate the cold inline isolating valve (see fig 10a, section 10).

Using a flat-blade screw driver, the screw can be rotated 90° anti-clockwise to isolate the cold water supply.

Before commencing the CWI test, ensure:

- The water supply conditions are met either:
 - For commissioning a new product (see table 1, section 4).
 - Or the inlet Δt is within $\pm 5^\circ C$ to when the product was commissioned (see 7.4)

NOTE It is important that the hot temperature is greater than 55°C

- Mixed water outlet temperature is correct (see table 2, section 8)

To perform a CWI test, operate the product by rotating the lever fully to the right.

Then conduct the following procedure:

- Record the steady state temperature of both hot and cold water supplies. Note the Δt .
- Record the temperature of the mixed water at the outlet.
- Isolate the cold water supply (by rotating the isolating screw 90° & monitor the flow of water from the outlet.

Fitting Field Test Audit (FC2)

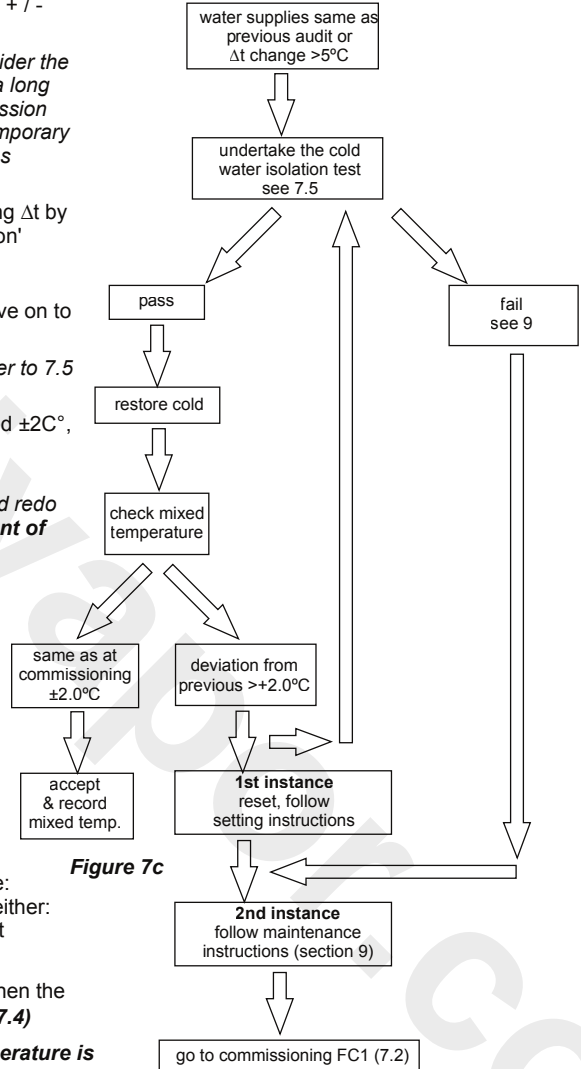

Figure 7c

If the flow ceases, CWI test passed:

1. Restore the cold water supply by rotating the isolator screw 90° clockwise.
2. Re-check the temperature of the stabilised mixed water at the outlet to ensure it is still correct.

Accept & record mixed temperature.

If there is an ongoing flow of water from the mixed water outlet, then 5 seconds after CWI collect the discharging water into a measuring vessel for 60 seconds. To pass the CWI test the volume of collected water should be less than 120ml.

If the product fails CWI test, see FC2 (**see section 7.4**) Follow product maintenance (**see section 9**) and servicing (**see section 8**) instructions.

8 SERVICING

The need for servicing is normally identified as a result of the regular performance auditing.

Application	Maximum mixed water temperature during normal operation	Permitted maximum stabilised temperature recorded during site testing – excluding transient spikes
Shower	41°C	43°C

Table 2 A guide to maximum temperature sets

8.1 FREQUENCY OF REGULAR SERVICING

This quick function check is permissible for in-service testing of thermostatic mixing valves:

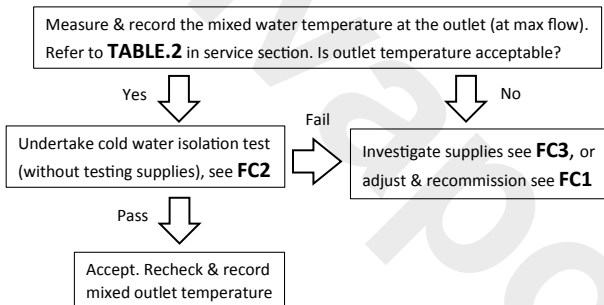

The purpose of servicing regularly is to monitor any changes in performance due to changes in either the system or the product. This may highlight the need to adjust either the supply system or the product. These products should be audited 6 to 8 weeks and again 12 to 15 weeks after commissioning.

The results are to be compared against original commissioning settings.

If the product passes the audit test three consecutive times (demonstrating good stability of system & product) then a 12 monthly servicing cycle may be adopted.

Otherwise, servicing checks should be carried out more frequently (E.g. every 4 months).

Follow the recommended auditing and maintenance procedures detailed in sections 7 & 9.

During servicing, note the following:

1. Repeat the procedure of recording and checking supply temperatures. (The same type of measuring equipment should be used)
2. If the temperature has changed significantly from the previously recorded valves, the following should be checked:
 - a. All in-line or integral valve filters are clear of obstruction.
 - b. All in-line or integral check valves are clean and working properly to prevent backflow.
 - c. Any isolating valves are fully open.
 - d. The thermostat is free of debris
3. When satisfied with the mixed outlet temperatures re-record the temperatures.

9 MAINTENANCE

When installed in a healthcare application, we recommend that the commissioning and maintenance procedures, detailed under 7 & 8, be carried out.

9.1 Adjustment of the mix temperature

• **Note: Cartridge is factory pre-set at 40±1°C at 3 bar**

1. Prise out the cover button on the handle & unscrew the retaining screw using a 4mm hexagonal key. Move the lever to the fully on (max) position & then remove the handle. Refer to section 5.2 Handle fixation.
2. Remove the face plate & black mouldings (see section 5.1). Slide off the cylindrical chrome shroud & grey spindle extension to expose the thermostatic cartridge.
3. Remove the upper Anti clockwise stop ring (slide off spindle).
4. Rotate spindle (use lever handle if necessary) to achieve correct mix temperature. (40±1°C) Rotate clockwise to reduce and anti-clockwise to increase.
5. Refit the upper stop ring against cartridge stop face.

Note: 1. this is the normal maximum temperature range for the product and as such there is a wide zone of spindle movement that gives this mix temperature. For best performance you should refit the stop at the first point of anticlockwise rotation that achieves the desired setting.

Note: 2. if you are unable to achieve 40 - 41°C Max and you have the correct Δt 's it may be due to fine debris. See 9.2 Removal and inspection of cartridge.

6. Upon successful completion of the temperature adjustment, conduct the Cold Water Isolation (CWI) test (See 7.5) to ensure product is working properly.
7. Refit the spindle extension, cylindrical shroud & face plate kit (see section 5.1). Refit the handle (see section 5.2).
8. Record the mix temperature.

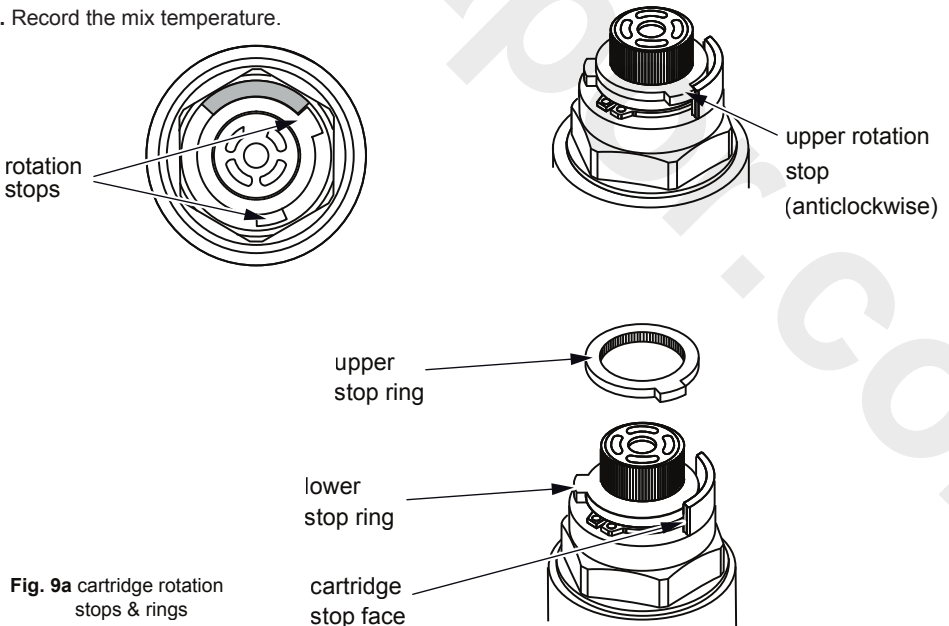
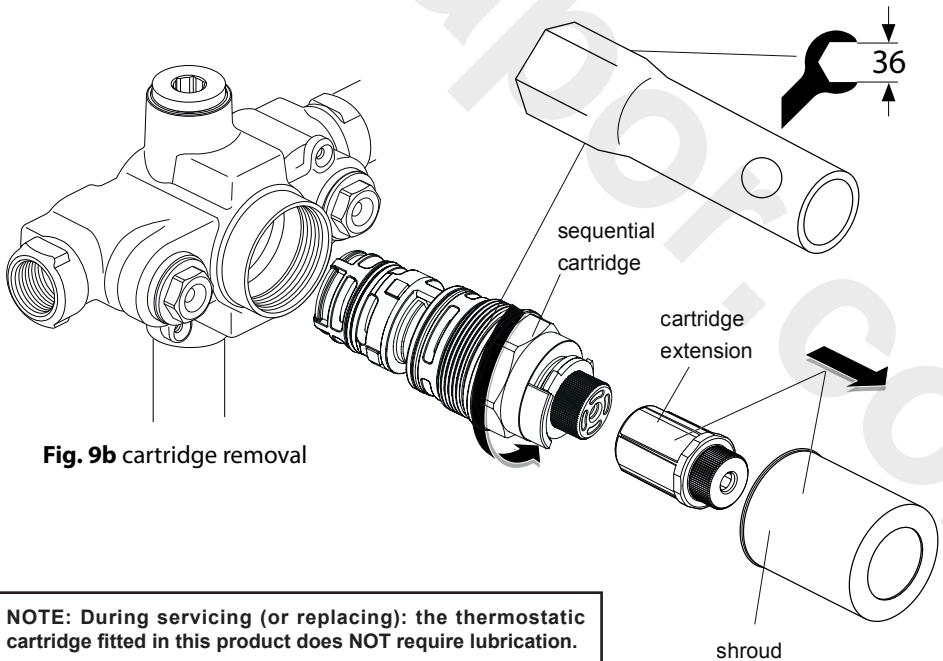

Fig. 9a cartridge rotation stops & rings

9.2 Removal and inspection of cartridge

After checking that supply conditions are within the specified parameters (see table 1), if the fitting malfunctions or should the test results fail to fall within the specified limits consider replacing the cartridge with a new one. **See 9.3 Important notes on debris.**

1. Remove the face plate (**see section 5.1 & 5.2**). Slide off the cylindrical chrome shroud & grey spindle extension to expose the thermostatic cartridge.
 2. Isolate the fitting by closing the isolating valves (**see section 10**).
 3. Unscrew the cartridge from the body with a 36mm A/F deep socket. Inspect cartridge for damage. Expect a small quantity of trapped water to escape when the cartridge is unscrewed.
 4. Replace cartridge if necessary and reassemble cartridge into body.
 5. The replacement cartridge should be tightened to a torque of 15Nm.
(To re-secure the cartridge we recommend the use of PermaBond A011 or equivalent applied to the thread of the cartridge)
 6. Reinstate the supplies.
 7. After fitting the new cartridge start the test procedure from the section on commissioning.
- Redo the Cold Water Isolation (CWI) test (**See 7.5**).
 - Once satisfied with the CWI test, re-check and if necessary, adjust the maximum mix temperature, (**See 9.1**).
 - Refit the spindle extension, cylindrical shroud & face plate (**see section 5.1**).
 - Refit the handle (**see section 5.2**).
 - Record the mix temperature.



9.3 Important notes on debris

Although this product is protected by built-in filters, debris can still find its way to the thermostat housing area. This can happen during servicing for example. Remove cartridge (see section 9.2) and carry out an inspection.

9.4 Thermostatic Cartridge Ageing

Following many years of normal service you may notice the following:

1. The need to carry out more frequent adjustment of mixed temperature.
2. The thermostatic element may not pass the CWI test.

These issues could be due to the ageing of the thermostat which loses some expansion capability over time.

These are the principle objectives of testing, as they serve to indicate to maintenance staff the declining performance capability of the thermostatic cartridge.

For this reason the audit testing flow chart highlights that 2nd Instance CWI test failure or 2nd instance mixed deviation even with stable 'as commissioned' supply conditions and correct inlet supply Δt 's, is potentially the first indication of the need to replace the cartridge.

10 INLINE SERVICE VALVES

The service valves contain filter & isolating valve functions.

Isolation valves facilitate 4 activities:

- 1) Cleaning strainers & check valves
- 2) Servicing the cartridge
- 3) Disinfection
- 4) Audit cold water failure testing

Strainers

Each service valve is fitted with a strainer (filter/mesh) to catch any waterbourne debris

To ensure trouble free operation of the fitting, the strainer elements should be checked and cleaned in accordance with the commissioning and servicing guide (see section 8).

To access the strainer element, simply close the isolating valve and unscrew the strainer cap. The strainer element should be washed with clean water and refitted.

Use a 22mm spanner on the strainer cap. Reopen the isolating valves upon completion. Expect a small quantity of trapped water to escape when the strainer cap is opened.

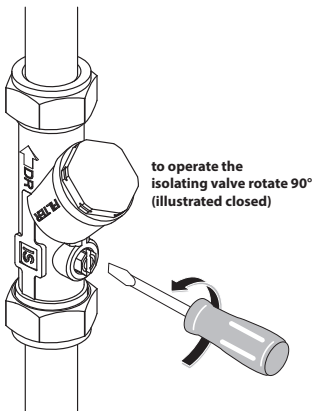

Fig.10a Operating the isolating valve

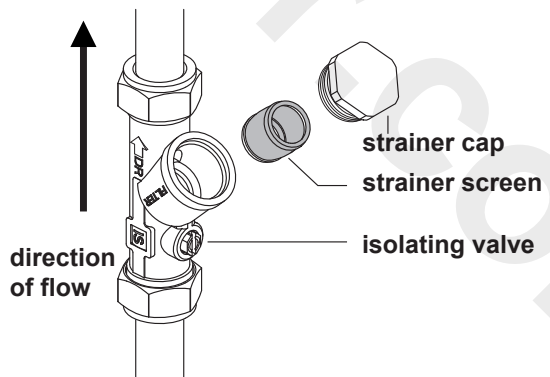

Fig.10b Exploded view of isolating valve

11 INTEGRAL COMBINED CHECK VALVES & FLOW REGULATORS

To access the combined check valves & flow regulators (CV15FR):

1. Remove the face plate (see section 5.1 & 5.2) to expose the shower valve. The CV15FR valve housings (x2) are integral to the shower valve as shown figure 11.

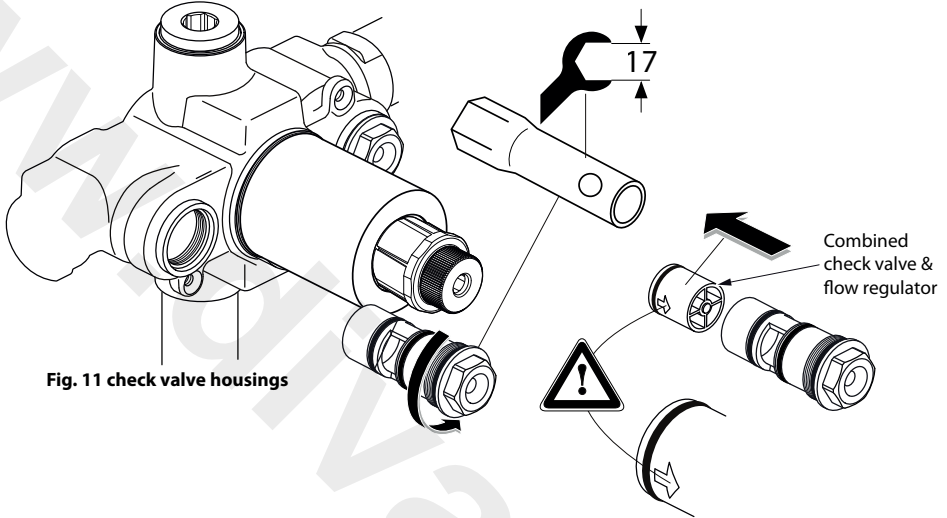

Fig. 11 check valve housings

2. Isolate the product, see section 10.
3. Use a 17mm spanner (or socket) to undo the CV15FR valve housings.
NOTE: Expect a small quantity of trapped water to escape when these housings are opened.
4. Slide the CV15FR valves out from the bottom of the housings.
5. Check/clean/replace the CV15FR valves. OBSERVE ARROW MARKING.
6. Refit the CV15FR valve housings into the shower valve.

Reopen the isolating valves upon completion of task & refit face plate etc...

To achieve a suitable flow rate where supply pressures are very low it may be necessary to remove the combined flow regulator (item 14a figure 12) and replace with a single check valve (item 14b figure 12).

PRODUCT MUST BE FITTED WITH CHECK VALVES, DO NOT REMOVE THESE.

NOTE: The flow regulator fitted in each CV15FR valve housing is nominally rated 5L/min. Therefore mixer is flow regulated to max 10L/min



For more information on spare parts why not visit our spare website:
www.fastpart-spares.co.uk. Or contact customer care

12 SPARE PARTS

Pos.	Part No.
1	A 962 017 AA
2	A 961 456 AA
3	A 961 464 NU
4	A 961 467 AA
5	A 960 054 AA

6	A 962 074 NU
7	A 961 481 NU
8	A 860 321 NU
9	A 963 344 NU
10	A 961 482 NU
11	A 962 280 NU

11a	F 960 879 NU	10 bulk pack
12	F 960 846 NU	
13	A 963 431 NU	
14a	F 961 081 NU	CV-FR
14b	A 962 594 NU	simple check valves
17	A 963 510 NU	

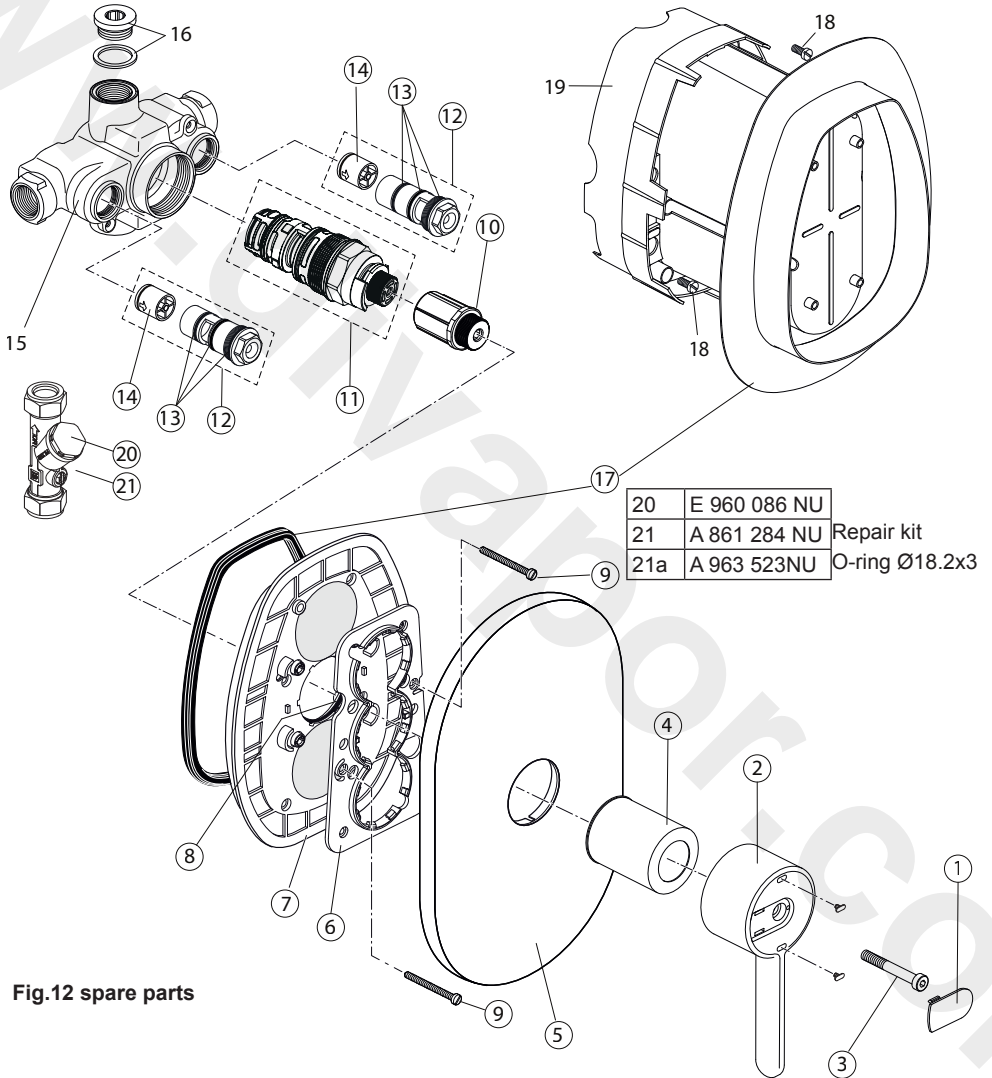
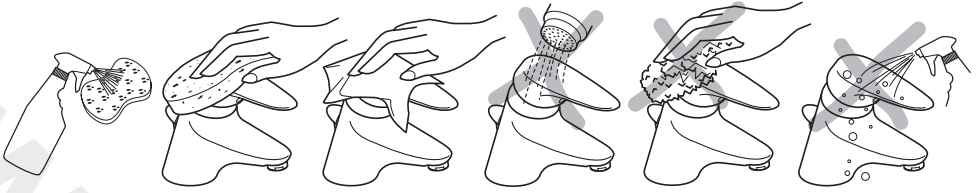

Fig.12 spare parts



For more information on spare parts why not visit our spare website:
www.fastpart-spares.co.uk. Or contact customer care

13 CLEANING CHROME SURFACES



When cleaning chromed products use only a mild detergent, rinse & wipe dry with a soft cloth. Ideally clean after each use to maintain appearance.

Never use abrasive, scouring powders or scrapers. Never use cleaning agents containing alcohol, ammonia, hydrochloric acid, sulphuric acid, nitric acid, phosphoric acid or organic solvents. Use of incorrect cleaning products / methods may result in chrome damage which is not covered by the manufacturer's guarantee.

For more information about our products visit our websites:
www.armitage-shanks.co.uk
www.idealspec.co.uk
www.fastpart-spares.co.uk

200
ARMITAGE SHANKS
THE NEXT 200 YEARS
ESTABLISHED 1817



AFTER SALES NON RESIDENTIAL HELPLINE
0870 122 8822

AFTER SALES NON RESIDENTIAL FAX
0870 122 8282

E-MAIL
aftersalesnonresidential@idealstandard.com

Armitage Shanks pursues a policy of continuing improvement in design and performance of its products.

This right is therefore reserved to vary specifications without notice.

Armitage Shanks is a division of
Ideal Standard (UK) Ltd

Ideal Standard International NV
Corporate Village - Gent Building
Da Vincilaan 2
1935 Zaventem
Belgium

www.idealstandardinternational.com

*Armitage
Shanks*

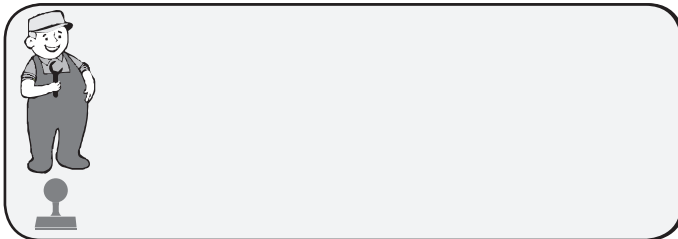

0919 / A 868 048
Made in Germany