

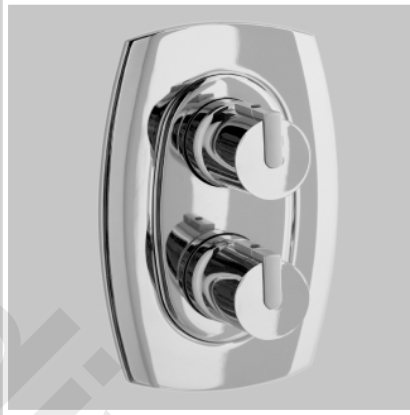

TREVI SHOWERS

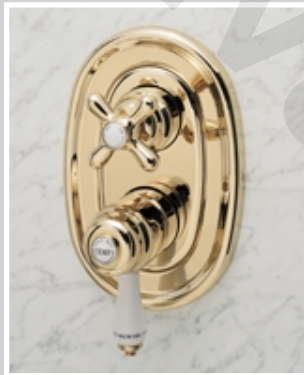

Trevi Outline



Trevi Traditional



Trevi Therm



TREVI
by Ideal-Standard

Installation Instructions

- A3000 Trevi Therm built-in thermostatic mixer
- A3700 Trevi Outline built-in thermostatic mixer
- E3115 Trevi Traditional built-in thermostatic mixer

INSTALLER:

After installation please pass this instruction booklet to user

1 GENERAL NOTES

Trevi thermostatic shower mixers are designed to be installed on normal UK low pressure storage tank fed systems, unvented high pressure systems, modulating instantaneous water heaters or modulating combination (combi) boilers. They are suitable for all pumped applications.

WATER REGULATIONS

Hot and cold water supply pressures must be reasonably balanced and from a common source - both from storage or both from a supply pipe. (IRN 101). The mixers will function within specification on unequal pressures up to a ratio of 5 : 1, but it is not recommended that the cold supply be connected to the rising main and hot to the tank fed supply as the pressure differential is likely to exceed the 5:1 ratio.

The minimum pressure for correct operation is 0.1 bar (1m head - see Figure 5). Pressure head is measured as the vertical distance between the bottom of the cold water storage tank which feeds the hot water system and the highest point on the shower spray plate.

When installing with a shower pump the use of a secondary tapping from the cylinder is highly recommended.

Figure 1 shows the various methods of connecting the hot water pipe to the cylinder - the most preferred on the left and the least preferred on the right.

The fitting should be so installed as to be readily accessible for examination, repair, replacement or operation. (IRN 111).

The temperature of the hot water must not exceed 85°C but the installer's attention is drawn to code of practice BS 6700 which recommends that stored hot water should normally never exceed 65°C. For correct operation of the valve, a minimum of 52°C is required.

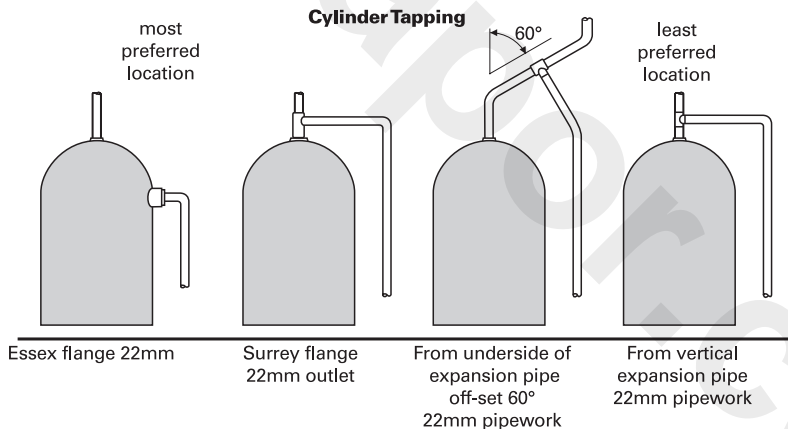

Figure 1 Preferred locations of cylinder tapping

FOR HEALTHCARE ESTABLISHMENTS

In accordance to NHS model engineering specification DO8 the valve has approval for the following applications: -

High pressure -HP-S

Low pressure -LP-S

TMV3 approval number: ETC/227/0903

Table 1 Conditions for normal use

Operating pressure range:	High Pressure	Low Pressure
Maximum static pressure - Bar	10	10
Flow pressure hot and cold - Bar	1 to 5	0.2 to 1
Hot supply temperature - °C	52 to 65	52 to 65
Cold supply temperature - °C	5 to 20	5 to 20
Temperature differential characteristic (TDC) °C	10	10

Valves operating outside of these conditions cannot guaranteed to perform as type 3. Approval only applies when the valves are installed without the flow restrictors illustrated in Figure 2.

When installing on a modulating combination boiler it is sometimes possible for the interaction of a thermostatic valve with the combi to cause the boiler to cut out and cut in again with the result that the water will become alternatively cold and hot. To overcome this, flow restrictors should be fitted upstream of the thermostatic valve.

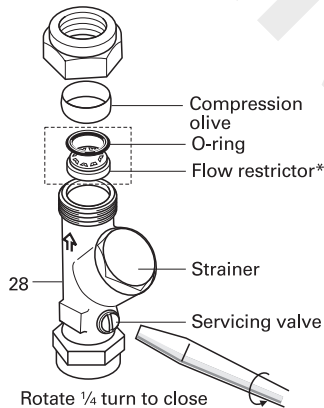

Figure 2 in-line filter and service valve showing restrictor

The Do8 approval of this fitting only applies when installed without the flow restrictors.

Trevi supply in-line strainers/servicing valves (28) which include these flow restrictors. These should be inserted in the downstream side of

the servicing valve as shown on Figure 2. It is essential that they are positioned the right way round as shown in the sketch. Remove the compression nut and olive from the outlet side of the Isolating valve and place the restrictor in the outlet. Push to the bottom of the recess. Fit O-ring in the visible rebate around the edge of the restrictor and push home until it is fully in the rebate. Use the tip of a small screwdriver or similar to achieve this.

Servicing valves should be fitted as close as is practical to the shower valve.

CATEGORIES OF RISK

The water regulations published in 1999* take a new approach to backflow in that they look at different categories of risk. The installer must assess the risk from the various categories of fluid in adjacent appliances before determining the level of backflow protection required for a particular installation. Figures 3 & 4 describe the protection required in various installations.

CATEGORY 3 RISK

Water in a shower tray, basin or bathtub is considered to be a fluid category 3 risk which is a fluid which represents a slight health hazard if it were to find it's way back into the supply pipe. For this reason it must not be possible for any flexible shower head to be able to enter any adjacent washbasin, bath or shower tray unless appropriate protection is employed. (See Figure 3).

*A guide to the Water Supply (Water fittings) Regulations 1999 and the Water Byelaws 2000, Scotland is published by WRAS (Water Regulations Advisory Scheme) Fern Close, Pen-y-Fan Industrial Estate, Oakdale, Newport, NP11 3EH. ISBN 0-9539708-0-9.

3 WATER REGULATIONS

If it is desired to allow the hand spray to be used inside say a bathtub or a basin it is essential that double check valves be fitted to the inlet on both hot and cold supplies to the thermostatic valve. Alternatively single check valves can be fitted at the inlets and an additional check valve should be fitted in the valve outlet.

No check valves need be fitted if the hand spray is prevented from reaching closer than 25mm of the spill over level of any such fixture.

CATEGORY 5 RISK

Water in a Sink, WC or Bidet is considered to be a fluid category 5 risk which is a fluid which represents a serious health hazard if it were to find it's way back into the supply pipe. For this reason it must not be possible for any flexible shower head to be able to enter any adjacent Sink, WC or Bidet. If the flexible hose to be fitted could reach into any such vessel, the requirements to the system design are so onerous it is better not to fit a flexible. Rather, a fixed overhead showerhead should be considered. (See Figure 4).

It will also be seen that this risk could change should the hose be taken out of the restraining device or should a longer replacement hose be fitted at a later date. Installers and householders are advised to take account of these factors when fitting replacement hoses.

For pumped applications the pipe supplying the pump must not in addition supply an ascending spray bidet.

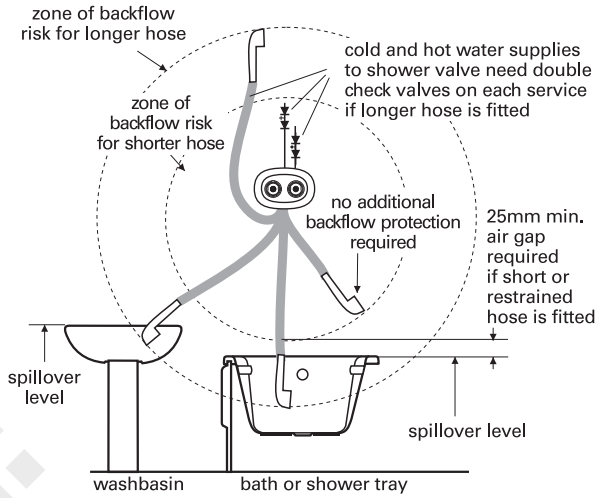

Figure 3 Illustration of backflow risk from fluid Category 3 risk

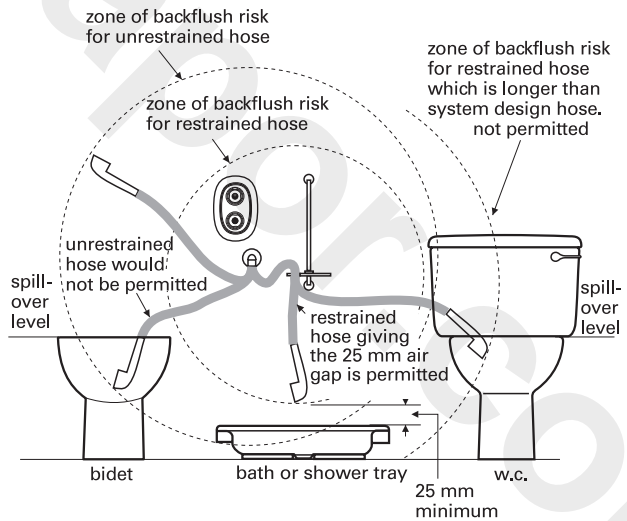

Figure 4 Illustration of backflow risk from fluid Category 5 risk

GRAVITY/PUMPED SYSTEMS

Note: When hot supply is routed above the ceiling, (for example, in the loft space), the high level pipes should be installed with a fall, and must be vented at the highest point

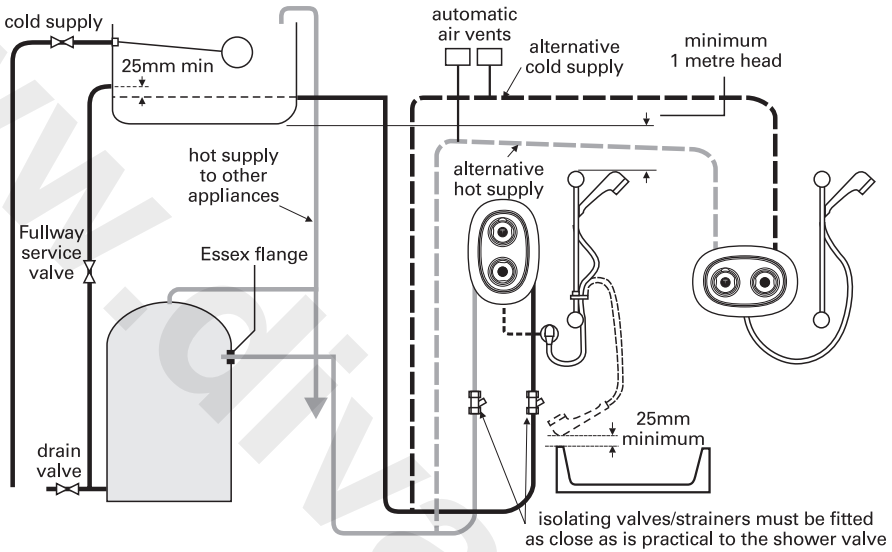

Figure 5 Recommended system layout for gravity applications

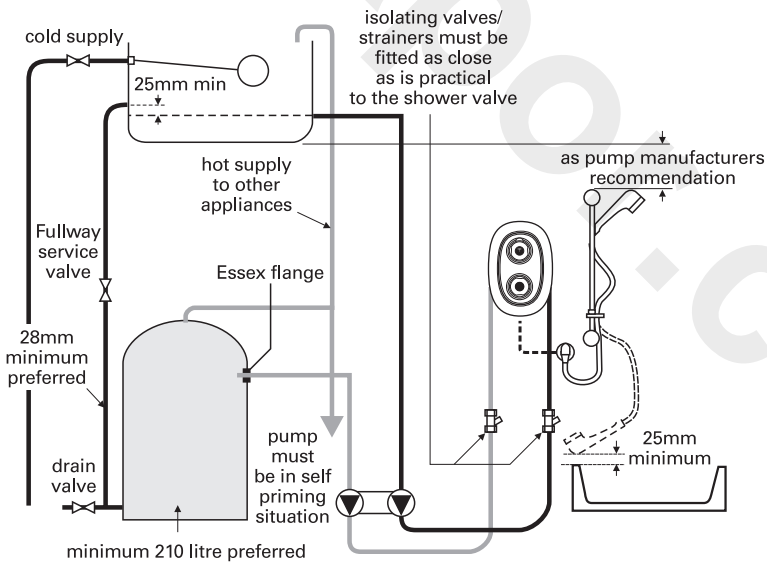

Figure 6 Recommended pumped system layout

5 DIMENSIONS

TECHNICAL DIMENSIONS

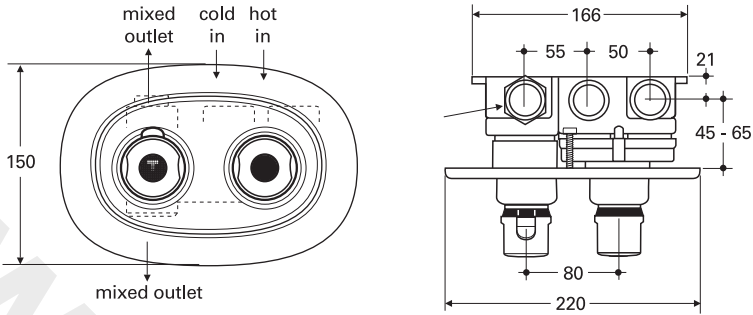

Figure 7 Trevi thermostatic shower valves - installation dimensions

INSTALLATION GUIDE

Connections on the built-in mixer body are $\frac{3}{4}$ " BSP (female) and are marked "hot in", "cold in" and "mixed out" on the body casting. There are two mixed outlet ports, one of which must be plugged with the blanking plug supplied. For maximum flow performance the unplugged outlet should be connected to the wall elbow or the fixed overhead shower using 22mm copper. The $\frac{3}{4}$ "/22mm connectors must be jointed to the valve body using jointing compounds or PTFE tape. Under no circumstances should soldered joints be used near the valve body as this will damage the fitting. It is recommended that isolation valves be fitted upstream of the valve body.

TREVI THERM A3000

The valve is supplied as per position 1 (Figure 8) with options for installation in positions 2, 3 & 4. Should positions 2, 3 or 4 be required then the temperature adjustment carrier will need to be repositioned so that the triangular raised mark at the rear is positioned at the top. The front handle carrier is rotated if necessary until the triangular indent is again at the top. The handle can then be pushed into position with the override button to the top.

TREVI OUTLINE THERMOSTAT A3700

This valve is supplied as per position 3. Since the wall plate is designed to be mounted vertically, position 4 is the only alternative orientation advised.

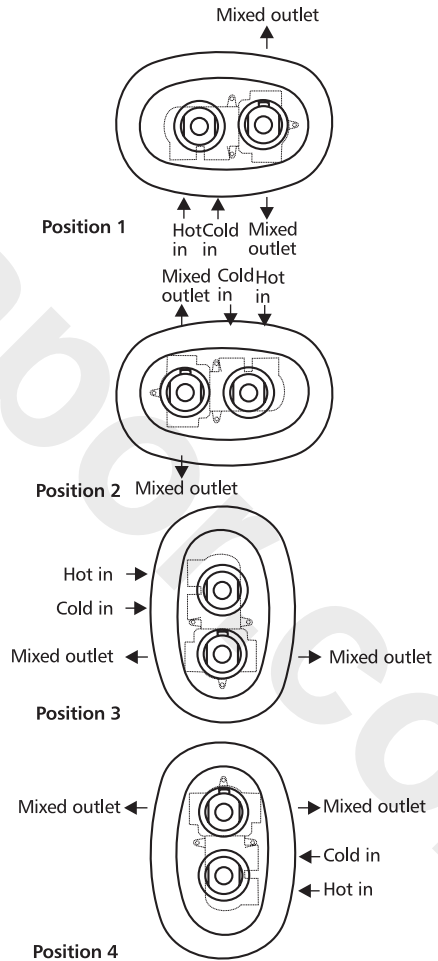

Figure 8

TREVI TRADITIONAL BUILT-IN E3115

Trevi Traditional is supplied as per position 3 (Figure 8) and should only be installed in this orientation. Connections are the same as for Trevi Therm and Trevi Outline.

Build-in guide

1. All the fittings covered by this instruction are designed to be recessed into the wall. The depth of the recess should be measured from the finished wall surface to the rear of the valve body. There is an adjustment of 20mm in the installation depth. Recess depth is in the range 66mm minimum to 86mm maximum. These minimum and maximum depths are marked on the plaster guard (26).

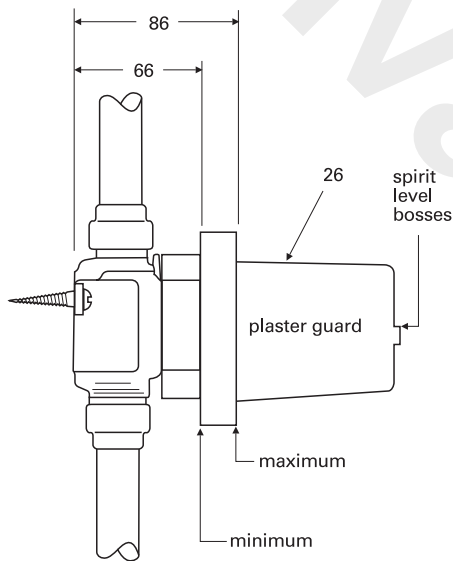

Figure 9

2. Chase out wall for mixer body and pipe work.

3. Remove plaster guard (26).

4. Fit blanking plug to appropriate port of the valve body and connect pipe work. (Do not solder near the valve body)

5. Replace plaster guard and check that the valve is horizontal (or vertical if positions 3 or 4 have been selected). The two bosses on the front of the plaster guard allow a spirit level to be placed on or against it. Check also that the valve is parallel to the wall surface.

6. Make good the wall by plastering around the valve up to the plaster guard.

7. Once the plaster has set the wall can be tiled and the plaster guard removed.

8. The temperature control handle can now be positioned so that the button is to the top (Trevi Therm and Trevi Outline Thermostat). If the valve is not being fitted in the position as supplied then the temperature adjustment carrier will have to be repositioned as described on Page 8 under thermostatic cartridge replacement.

9. **The pipe work and valve body must now be flushed out.** Failure to do so will cause the thermostatic cartridge filters to become blocked resulting in reduced or erratic performance. The procedure for this is described on Page 7 under replacement of cartridges.

10. Fit the back cover plate and secure using the fixing screws (3). (These may need to be cut if valve is installed close to the minimum depth). Push front cover plate into position and fit operating handles.

7 VALVE REPLACEMENT

CARTRIDGE REPLACEMENT

Flushing and replacement of cartridges & gear clutch wheels

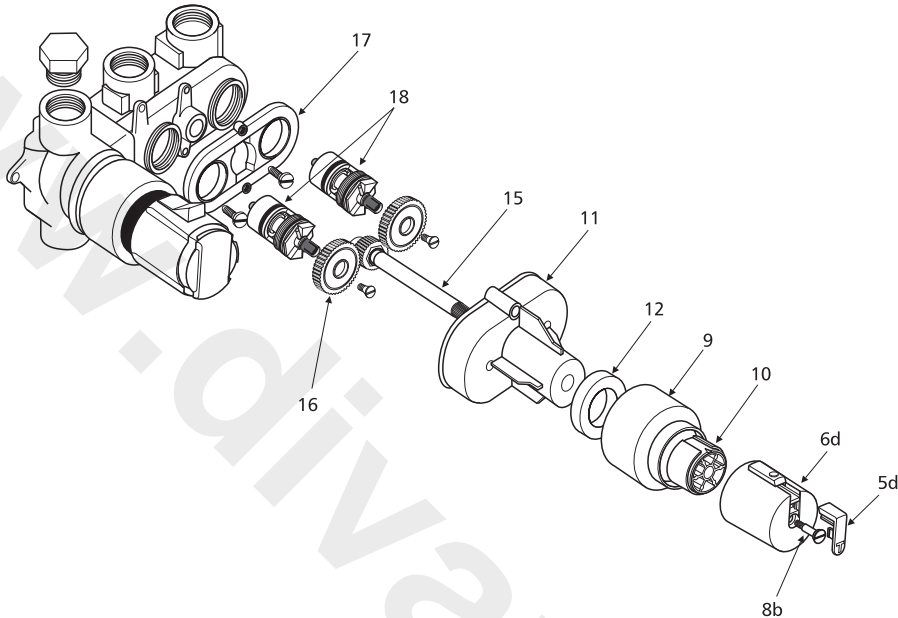

Figure 10

1. Remove handles. (see Pages 10/11 for details)
2. Remove the front cover plate (1) by prising forward using the small slots at the sides of the front cover plate.
3. Remove the two cover plate screws and pull off the back cover plate (2).
4. Remove the volume control handle (6) and carrier (10) by unscrewing screw (8b) and pulling off.
5. Pull off shroud (9)
6. Remove the two gear box cover fixing screws and pull off the gear box cover (11).
7. Pull out the drive shaft (15)
8. Loosen the two cartridge cone screws and remove the gear/clutch wheels (16) by pulling forward.
9. Lift off the rear gear box cover (17)
10. Isolate the shower valve from the supplies and unscrew the two cartridges (18) anticlockwise
11. Fit the flushing adapter (25) in place of the cartridges in turn and flush the pipework.
12. Assemble the valve in reverse order.
13. If fitting replacement cartridges and/or clutches they should be fitted at this stage.
14. Both cartridges must be in the closed position before fitting the gear clutches (16) in position.

THERMOSTATIC CARTRIDGE REPLACEMENT

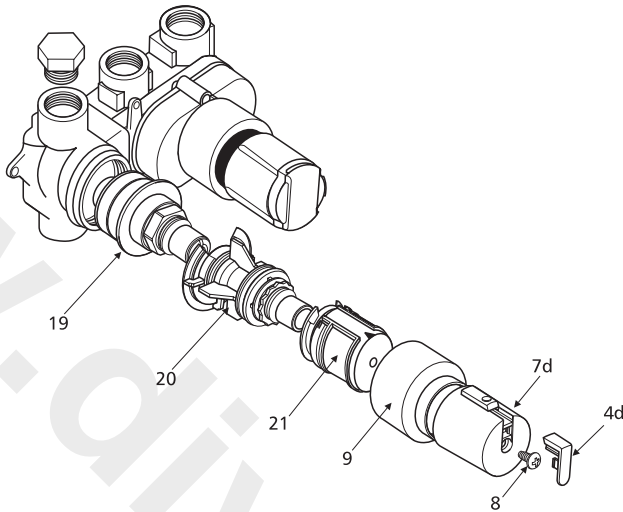

Figure 11

1. If the volume control handle is in the off position it should not be necessary to isolate the valve from the supply for this operation.
2. Remove handles (7). (see pages 10/11 for details)
3. Remove the front cover plate (1) by prising forward using the small slots at the sides of the front cover plate.
4. Remove the two cover plate screws (3) and pull off the back cover plate (2).
5. Remove shroud by pulling forward (9)
6. Remove the temperature adjustment carrier (21) by rotating the black locking latch and pulling forward.
7. Remove the rear temperature handle extension (20) by rotating the black locking latch and pulling forward.
8. The thermostatic cartridge (19) can now be removed by turning anticlockwise.
9. It is usually unnecessary to fit a new thermostatic cartridge. Most problems occur because debris from the pipe work has blocked the cartridge filter screens.
10. The cylindrical filter screens can be removed for cleaning by removing the o-rings from the cartridge and sliding the screens off. Do not attempt to refit the cartridge with the filter screens missing. Any small particles of grit in the water supply will cause the mechanism to jam. (Place all components which have grease on them on a clean piece of paper to avoid picking up grit)
11. Grease the cartridge o-rings with silicone grease when they have been refitted.
12. If a replacement cartridge is being fitted, fit it at this stage.
13. The valve is assembled in reverse order.

9 CALIBRATION

Details of the recommended code of practice for safe water temperatures can be found on the Thermostatic Mixing Valve Manufacturers Association web site: www.tmva.org.uk

The rear temperature handle extension (20) can be fitted on to the thermostatic cartridge (19) in any position.

The temperature adjustment carrier (21) will need to be refitted with the triangular raised mark on the rear of the carrier in the top position. Providing this assembly has not been separated, (i.e. the red clip removed) the unit will remain calibrated and no adjustments will be required. Ensure that the front handle carrier is rotated fully anticlockwise before refitting otherwise difficulty will be experienced in fitting the temperature adjustment carrier to the rear temperature extension. The temperature handle is then refitted with the override button again in the top position.

CALIBRATION

Trevi thermostats are factory calibrated and require no further calibration during installation. However, if the temperature adjustment carrier is accidentally disturbed and the calibration altered it is a simple procedure to recalibrate the unit. Before starting this you will need to ensure the hot supply temperature is above 52°C.

1. Remove the temperature control handle.
2. Remove the red U-clip (b) from the temperature adjustment carrier. Remove the front carrier (e).
3. Ensure the raised triangular mark (a) on the rear handle carrier is to the top.
4. Rotate the temperature adjusting spindle (d) until a temperature of 40°C is measured at the outlet.
5. Replace the front handle carrier ensuring the triangular indent (c) is to the top.
6. Refit the red U-clip.
7. Refit the temperature handle.

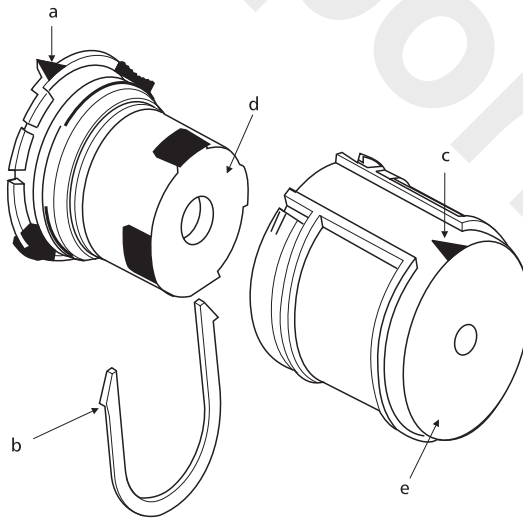

Figure 12

The thermostatic cartridge seldom fails and the possibility of blocked filters should be investigated before contemplating replacing it.

Although the Trevi Therm is supplied with strainers in the separate servicing valves, small particles of debris may find their way past this and onto the filter screens in the thermostatic cartridge. These should be cleaned and refitted. See section on cartridge replacement.

This shower valve has safety characteristics superior to the previous version of the Trevi Therm and is approved to TMV3 standard, which allows it to be used in hospitals, nursing homes and residential care home. When installed in such establishments it is a requirement that the following commissioning and maintenance procedures be carried out. For normal domestic installations these checks are not a requirement.

COMMISSIONING & PERIODIC CHECKS

The following procedures should be carried out after installation and every 6 months after to ensure that the valve is functioning correctly.

Check that:

1. The application of the thermostatic valve matches the approved designation.
2. The supply pressures are within the recommended range for the application.
3. The supply temperatures are within the permitted range for the application and comply with the guidance for prevention of Legionella.

4. The mixed temperature is as required for the application.

Record:

5. Each hot and cold supply. (Make a note of the measuring device used).
6. The mixed water temperature at the outlet device.

Isolate:

7. The cold supply to the mixing valve and record the mixed water temperature. The temperature should not exceed the value given in table (1) below.

TABLE (1)

A guide to maximum temperature sets

Application	Mixed Water temperature	Permitted maximum temperature rise during site testing
Shower	41 °C	43 °C

FREQUENCY OF REGULAR SERVICING

The purpose of servicing regularly is to monitor the performance of changes in system and valve set up. This may require the need to adjust either the supply system or the valve. The A3000, A3700 or E3115 should be checked and tested 6 to 8 weeks and again 12 to 15 weeks after commissioning. The results are to be compared against original commissioning settings. If there is no significant change (i.e. less than 1K) then a 6 monthly servicing cycle may be adopted. If the temperature increases up to and greater than 2K at the mixed water outlet, then servicing checks should be carried out more frequently, (every 4 months).

The following procedure is recommended for all servicing:

1. Repeat the procedure of recording and checking supply temperatures. (The same type of measuring equipment should be used).
2. If the temperature has the changed significantly from the previously recorded valves, check the following :
 - a) **All inline or integral valve filters are clear of obstruction.**
 - b) **All inline or integral check valves are**

clean and working properly to prevent backflow.

c) Any isolating valves are fully open.

3. When satisfied with the mixed outlet temperatures re-record the temperatures. If the change in temperature of the mixed water is extreme it is advisable to increase the frequency of servicing, unless temperature stability is achieved.

11 HANDLE FIXATION/REMOVAL

Trevi Traditional

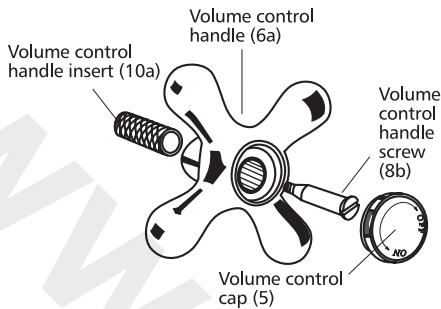

Figure 13 Fitting Trevi Traditional volume control handle

The volume and temperature control handles are not pre-fitted but are supplied packed with the valve.

The Traditional valve should be fitted only in position 3 as shown as in Figure 8

1. Push the volume control handle insert (10a) into the volume control handle (6a) and push this assembly on the drive shaft (15).
2. Secure with the screw (8b) and finally push the cap (5) into place

For correct operation the temperature handle must be fitted as follows

1. The temperature adjustment carrier is fitted as below.

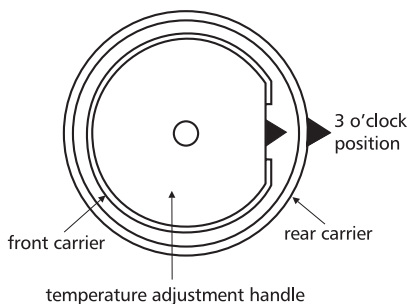

Figure 14

2. To fit the temperature handle (7a), push it onto the temperature adjustment carrier (21) with the lever at the 4 o'clock position. The wide key on the inside of the lever should engage with the key way on the temperature adjustment carrier (21).
3. Secure the lever with the screw (8)

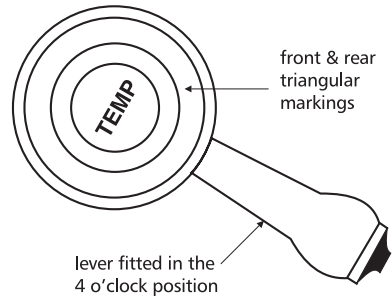

Figure 15

4. When the lever is moved to the 6 o'clock position the water temperature should be approximately 35°C
5. To increase the temperature, move the handle anticlockwise. See Figure 16

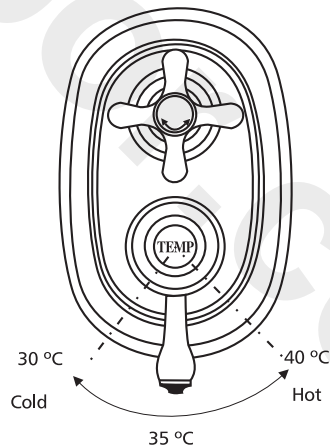

Figure 16

Trevi Therm and Trevi Outline

To remove the Outline handles, the cover slip (4d or 5d) should be prised up by inserting a small screw driver in the recess as shown. Care should be taken not to scratch the handle while doing this and it is advisable to wrap a piece of masking tape or similar around the screw driver as shown.

Unscrew screw (8b) and slide the handle off. The handle carrier can then be removed.

To replace the handle slide onto handle carrier (10) ensuring the key inside the handle engages with the keyway in the carrier (10).

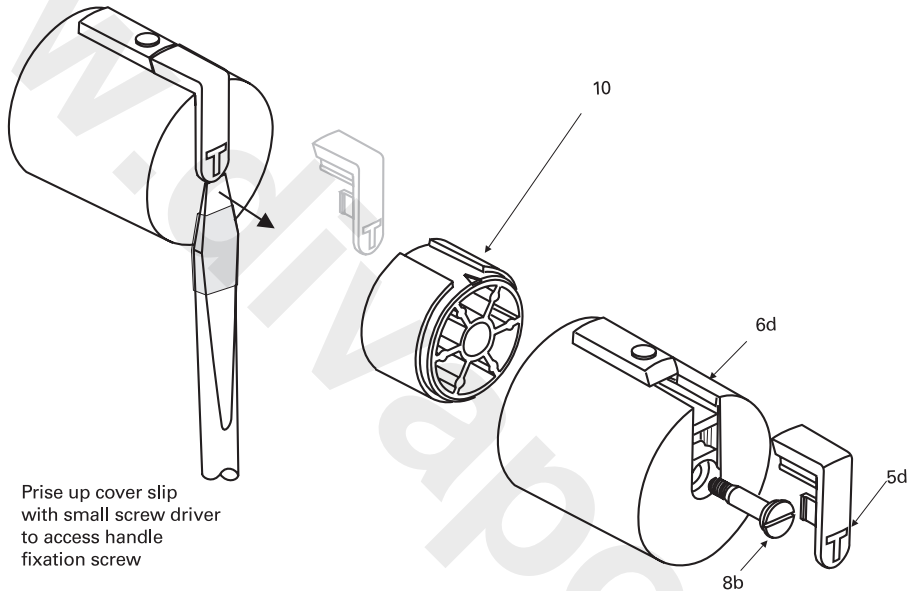
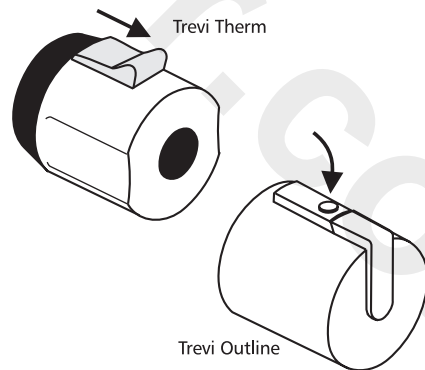

Figure 17

Temperature over-ride button

The Trevi Therm and the Trevi Outline Thermostat (but not the Trevi Traditional) are fitted with a temperature over-ride button. Normally this is pre-set to limit the temperature to 40°C. However, higher temperatures may be obtained by pressing the button and rotating the temperature handle further.

The Trevi Therm button slides outwards and the Trevi Outline Thermostat button pivots inwards as shown.



13 SPARE PARTS

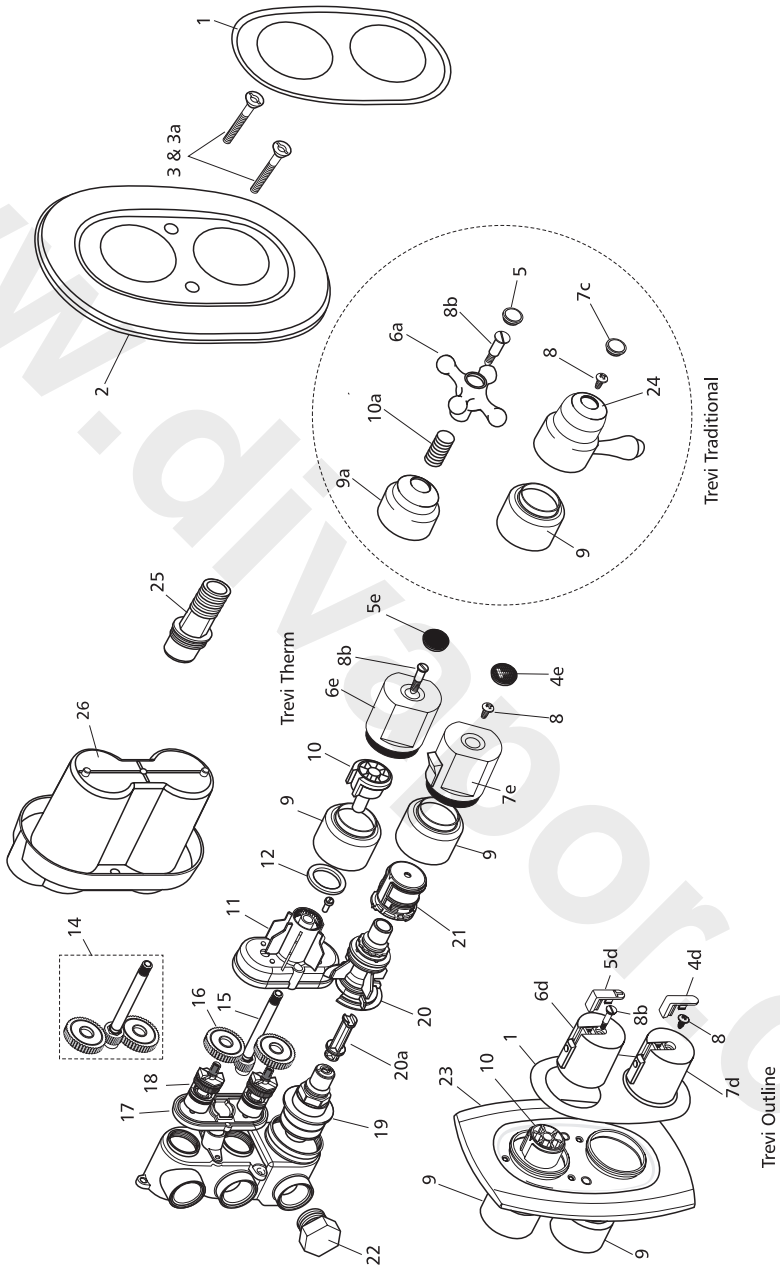

Figure 19

Ref.	Description	Ref.	Description
1	Front cover plate	10	Volume control handle carrier
2	Wall plate for Trevi Therm & Traditional	10a	Traditional volume control handle insert
2a	Cover plate sealing rings	11	Gear box cover
3	Cover plate fixing screws 50 mm	12	Gear box sealing washer
3a	Cover plate fixing screws 60 mm	13	Gear box cover fixing screws
4d	Outline temperature handle cover slip	14	Gear/clutch wheels complete
4e	Trevi Therm Temperature handle cap	15	Gear/ wheel drive shaft
5	Traditional volume control handle cap	16	Gear/clutch wheels
5d	Outline volume handle cover slip	17	Gear box back plate
5e	Trevi Therm volume handle cap	18	1/2" cartridge
6a	Traditional volume handle	19	Thermostatic control cartridge
6d	Outline volume handle	20	Temperature handle extension
6e	Trevi Therm volume handle	21	Temperature adjustment carrier complete
7c	Traditional temperature handle index	22	Blanking plug
7d	Outline temperature handle	23	Outline wall plate
7e	Trevi Therm Temperature handle	24	Traditional temperature handle
8	Self tapping handle screw	25	Flushing adapter outlet
8b	Long volume handle screw	26	Mounting template/plaster guide
9	Standard Shroud	27	Mounting template/plaster guide screws
9a	Traditional Volume control handle shroud		

www.divaport.com



Trevi Showers.
The Bathroom Works,
National Avenue,
Kingston upon Hull,
HU5 4HS
England.
Telephone: 01482 470788
Fax: 01482 445886

CUSTOMER CARE HELPLINE
0870 1296086
FAX LINE 01482 499611
email: ukcustcare@aseur.com

Trevi Showers pursue a policy of continuing improvement in design and performance of its products.

The right is, therefore, reserved to vary specifications without notice.

Trevi Showers is a division of
American Standard Plumbing (UK) Ltd.

T 096 09/03

E965033