

TREVI FLIGHT

THERMOSTATIC BATH SHOWER MIXER AND SHOWER VALVE



Installation Instructions

A3549AA Flight Wall Mounted Bath Shower Mixer

A3550AA Flight Wall Mounted Shower Mixer

E960440AA Legs for Rim Mounting



TREVI

by Ideal-Standard

INSTALLER:

After installation please pass this instruction
booklet to user

The Flight thermostatic mixers are designed to be installed on high pressure systems where the minimum supply pressure is 1.0 Bar. They must be fitted with a high pressure shower kit.

They are suitable for modulating combination boiler systems, unvented hot water supply systems (UHWSS) and other mains pressurised systems. They are also suitable for pumped applications.

The wall mounted version (150mm centres) can be converted to rim mounted (180mm centres) using the optional legs.

Supply pressures

Optimum: 0,1 MPa- 0,5 MPa
(1 - 5 bar / 14,5-72,5 psi)

Minimum: 0,1 MPa (1 bar / 14,5 psi)

For pressures > 0,5 MPa (5 bar / 72,5 psi) a pressure reducing valve should be used. Hot and cold supply pressures must be balanced and from a common source.

Technical data

Flow rate at 0,3 MPa (3 bar / 43,5 psi)
= 23 l/min

Temperature: 80°C max.

Test pressure: 1,6 MPa (16 bar / 232 psi)max

Flexible shower hoses and backflow protection

The water regulations place a duty on installers to ensure that flexible shower hoses cannot create a backflow risk. This risk exists when it is possible for a flexible shower outlet to enter any sanitary vessel.

To make it easy for installers to comply with the regulations, Trevi has included a screw-to-wall restraining bracket (29) with the Flight thermostatic valves.

This restraining bracket should be sited such

that when the flexible shower hose is passed through it, the spray head cannot enter any adjacent sanitary appliance. The three sketches below summarise its use.

If it is required to allow the spray head to enter an adjacent bath, shower tray or basin, both Inlets to the mixer must be protected by single check valves. (This is not permitted in health care establishments.)

It must never be possible for the spray head to enter an adjacent bidet or W.C.

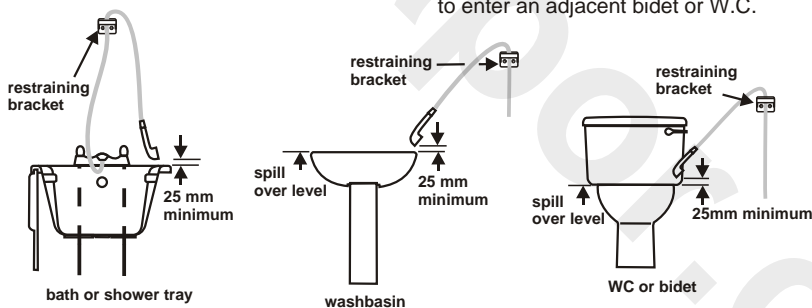
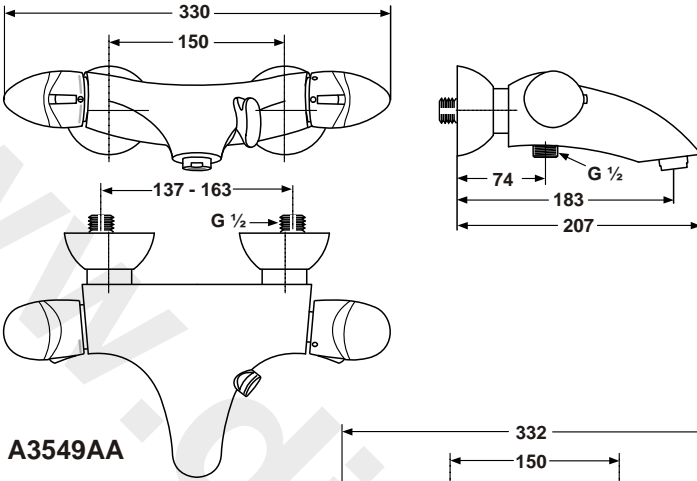

Figure 3 Use of restraining bracket

The fittings covered by this installation and maintenance instruction should be installed in accordance with the water regulations published in 1999*, therefore American Standard strongly recommend that these fittings are installed by a professional installer

*A guide to the Water Supply (Water Fittings) Regulations 1999 and the Water Byelaws 2000, Scotland, is published by WRAS (Water Regulations Advisory Scheme) Fern Close, Pen-y-Fan Industrial Estate, Oakdale, Newport, NP11 3EH.
ISBN 0-9539708-0-9



A3549AA

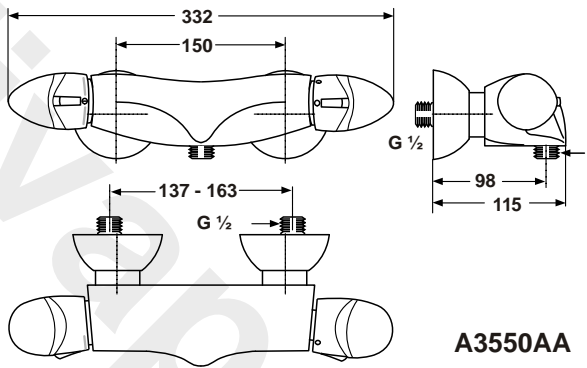

A3550AA

Operation

Note - The diverter switches from bath filler to shower by back-pressure. The tub filler must be fitted with a Neoperl. The shower flow rate should not exceed 20 litres / min. at 3 bar.

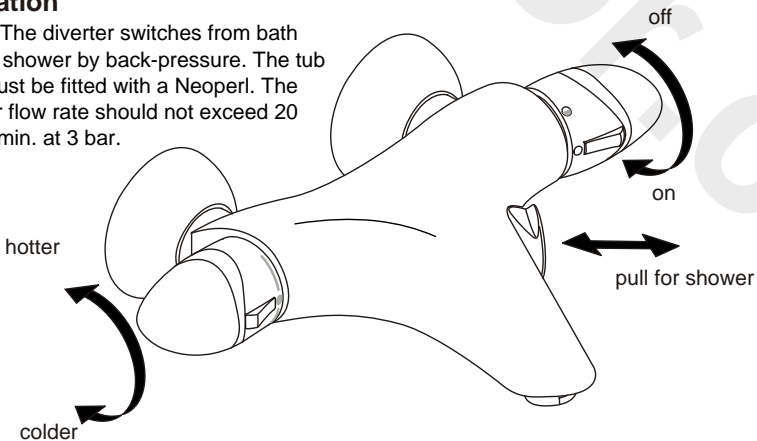

Wall Mounted

The supply pipes will have to be positioned in the wall terminating in backplate elbows. These should be at 150mm centres and flush with the tiled wall surface such that the S-connectors can be installed to project 34-39mm. Flush out the supply pipes thoroughly to remove any installation debris. Line up S-connectors and seal in position.

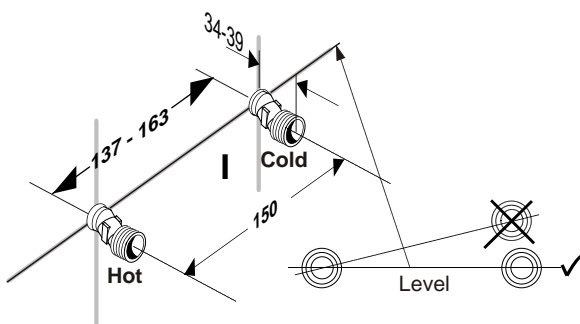

Assembling the collars:

Screw inner collar (19) back into the outer collar (18). Slide complete collar assembly over the S-connector. Screw mixer into position on the S-connectors with the coupling nuts (13). Open supply pipes and check that all connections are functioning properly and are leak-tight. Draw complete collar assembly over the hexagonal union nut (13) and screw the outer collar with clockwise rotation against the tiles. The inner collar fits against the mixer body and covers the coupling nut.

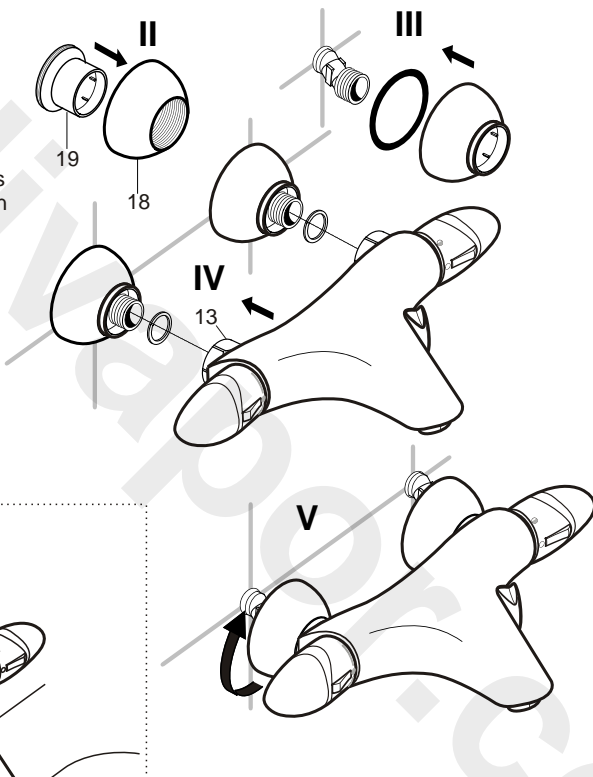

Rim mounted

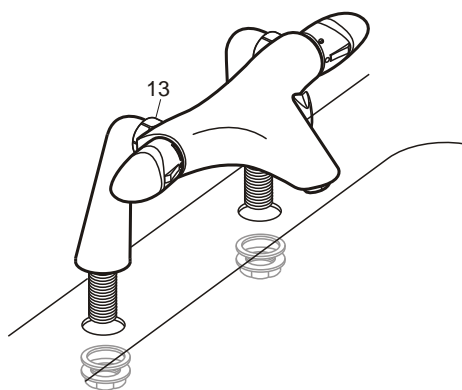

The bath shower mixer can be rim mounted by attaching to the optional inlet legs. Attach the legs using the coupling nut (13) and complete the installation as for conventional rim mounted bath shower mixers. See left.

Temperature adjustment

Pull off the handle cap (1).
 Undo and remove screw (2).
 Pull off temperature-control knob (4).
 Turn the water on with knob (5).
 Turn the knob mount (6) to the left or right until the spout temperature is 40°C. Then shut the water off again using knob (5).

Check that the arrow marking **D** is aligned with the reference hole **G**

on the mixer body. If not, pull the red locking clip **C** out backwards, pull the knob mount (6) off to the left, and refit it so that the arrow marking **D** and the horizontal reference **G** are exactly aligned.

Re-fit the locking clip **C**. Now slip on the knob (4) - the stop button should align with the reference hole **G** - and screw it tight with screw (2). Replace handle cap (1)

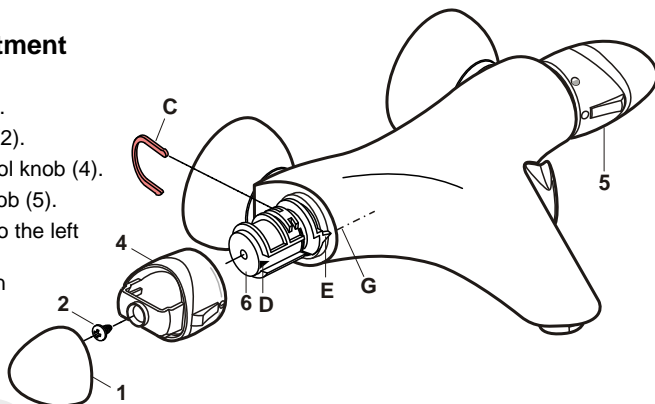

Replacing the check valve (14)

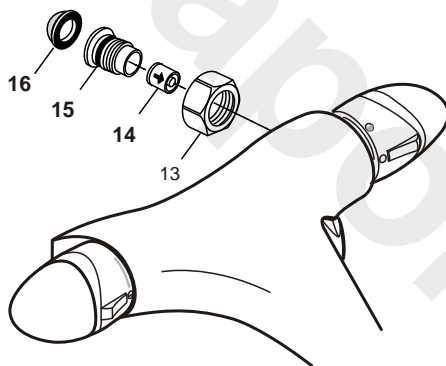

Shut off the supply pipes. Screw off the thermostat unit by loosening coupling nuts (13) uniformly with an open-jawed spanner size 30mm. Screw off seating piece (15) with an Allen key size 12mm (**left-hand thread**).

Remove check valve cartridge (14) from the seating piece and insert a new one. Make sure the flow direction is correct.

Screw the seating piece (15) back in (**left hand thread**) ensuring the coupling nut (13) is attached.

Refit the strainer (16), then re-install the thermostat unit.

Check that all the connections function correctly and do not leak.

Replacing the 180° cartridge (11)

Shut off mains water supply. Pull off the handle cap (1). Undo screw (3) and remove knob (5).

Take off the knob mount (10) with its stop ring sideways. Remove the cartridge (11) by turning it anti-clockwise (spanner size 22mm) and replace it with a new, lightly greased cartridge.

Turn the mains water supply back on and check that all connections function correctly and do not leak.

Then close the new cartridge by turning it clockwise.

Re-install the stop ring and knob mount (10) so that the arrow markings **H** and **J** align with the reference horizontal **G**.

Push the knob (5) with the stop button to the front back on and screw it tight.

Press the handle cap back on with the gap provided for ease of removal facing to the rear.

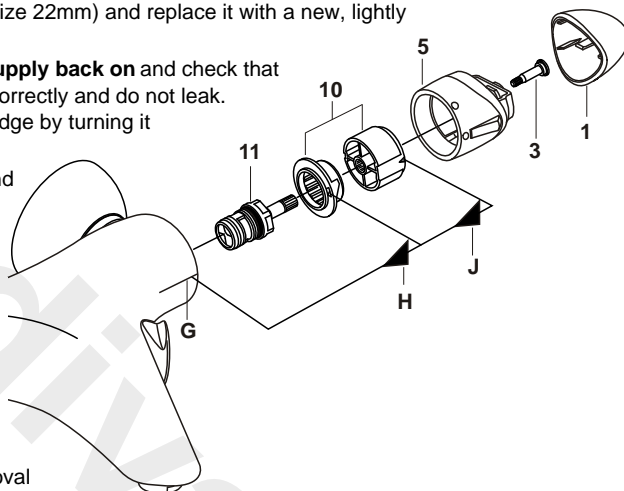

Replacing the temperature control unit (7)

Shut off the mains water supply.

Pull off handle cap (1). Undo and remove screw (2). Pull off temperature control knob (4). Press the black clamp **F** on the securing ring down and simultaneously remove the entire temperature control unit 6 sideways.

Remove the cartridge (7) by turning it anti-clockwise (spanner size 24). Screw in the new cartridge (lightly grease the O-rings only) and then **turn the mains water supply back on**.

Start the water running with knob (5). Check that there are no leaks.

Refit the temperature control unit (6), making sure that the arrow marking **E** aligns with the reference horizontal **G** and that the black securing ring locks back in place.

Now re-assemble the remaining parts and carry out the 40°C adjustment as described under

Temperature adjustment.

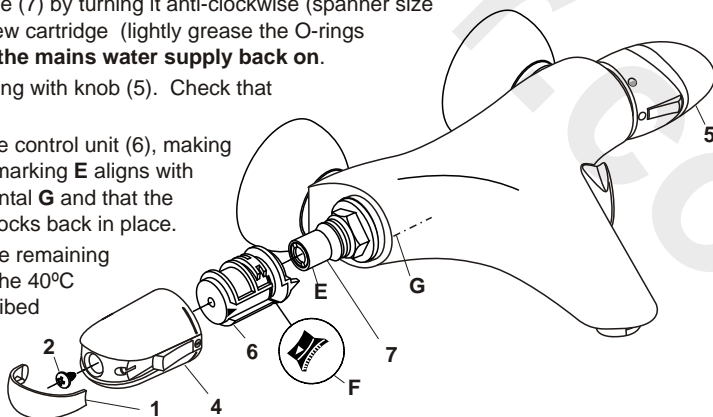

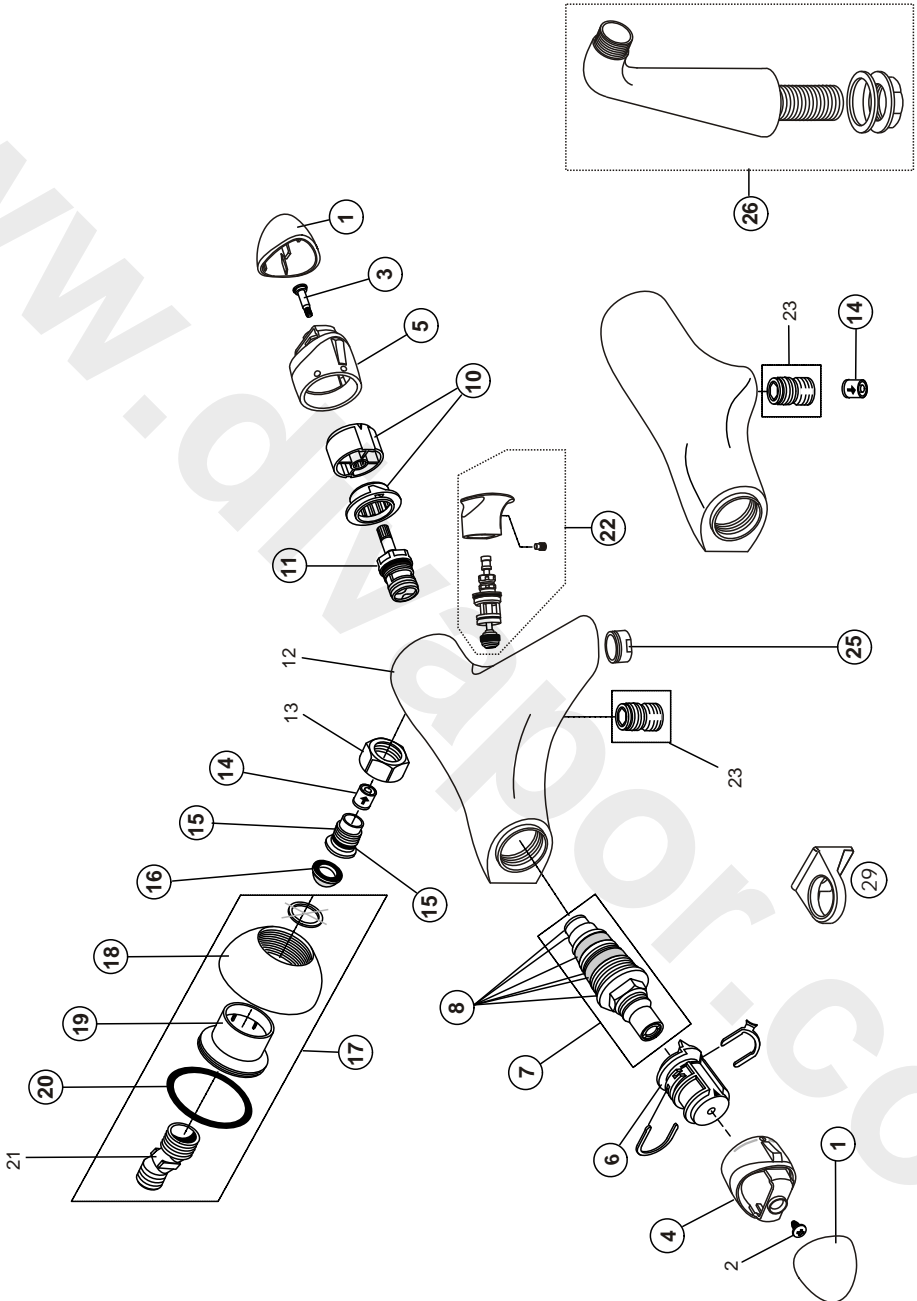

Ref.	Description	Ref.	Description
1	Handle cap	16	Noise screen
3	Screw	17	S-connector and escutcheon set
4	Temperature handle cover	18	Escutcheon
5	Flow control handle cover	19	Inner collar
6	Temperature handle carrier	20	Wall seal
7	Thermostatic cartridge	21	S connector
8	Thermostatic cartridge repair kit	22	Diverter complete
10	Flow control handle carrier and stop ring	25	Neoparl
11	Flow control cartridge	26	Legs for rim mounting
14	Check valve	27	Return to wall elbow
15	O-ring	29	Restraining bracket

Cleaning

When cleaning the fitting, only use saponaceous (i. e. soap - based) agents. Never use abrasive or scouring powders, cleaning agents containing alcohol, ammonia, nitric acid or phosphoric acid, or disinfectants.

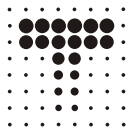

TREVI

by Ideal-Standard

Trevi Showers
The Bathroom Works
National Avenue
Kingston-upon-Hull
HU5 4HS
England

CUSTOMER CARE HELPLINE

0870 129 6085

CUSTOMER CARE FAX

01482 499611

E-MAIL

ukcustcare@aseur.com

Trevi Showers pursues a policy of continuing improvement in design and performance of its products.

The right is therefore reserved to vary specification without notice.

Trevi Showers is a division of American Standard Plumbing (UK) Ltd

TS112 10/04

E96547100