

TECHNICAL INFORMATION

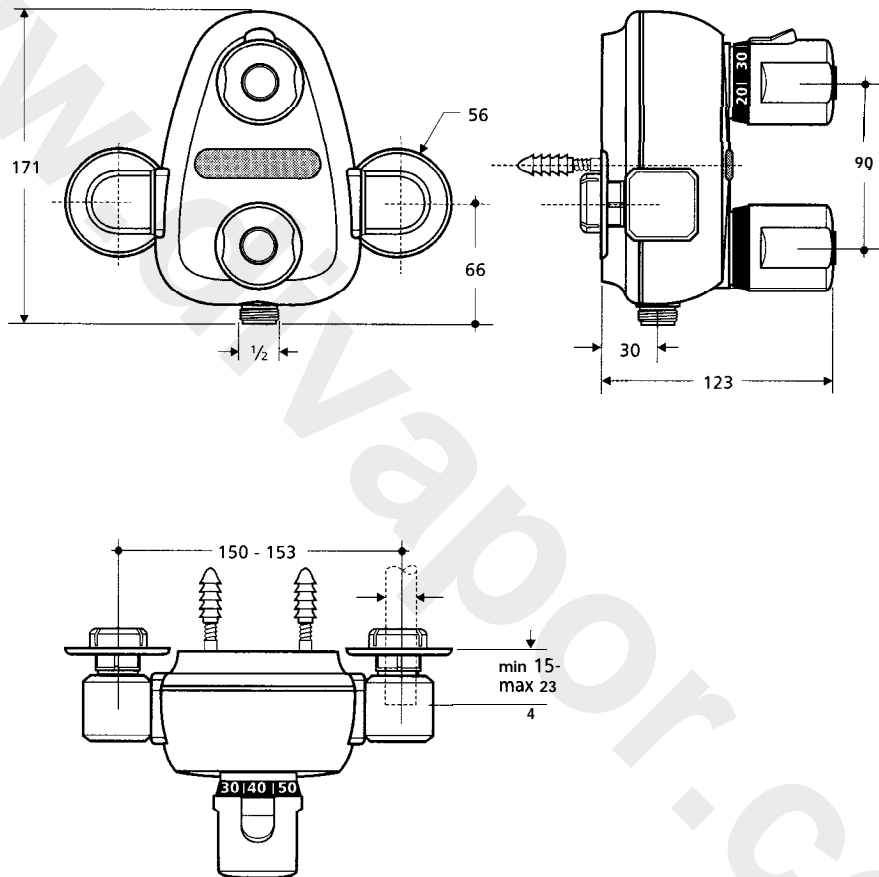

Fig. 1

All dimensions shown in millimetres.
Dimensions shown may vary within permitted tolerances

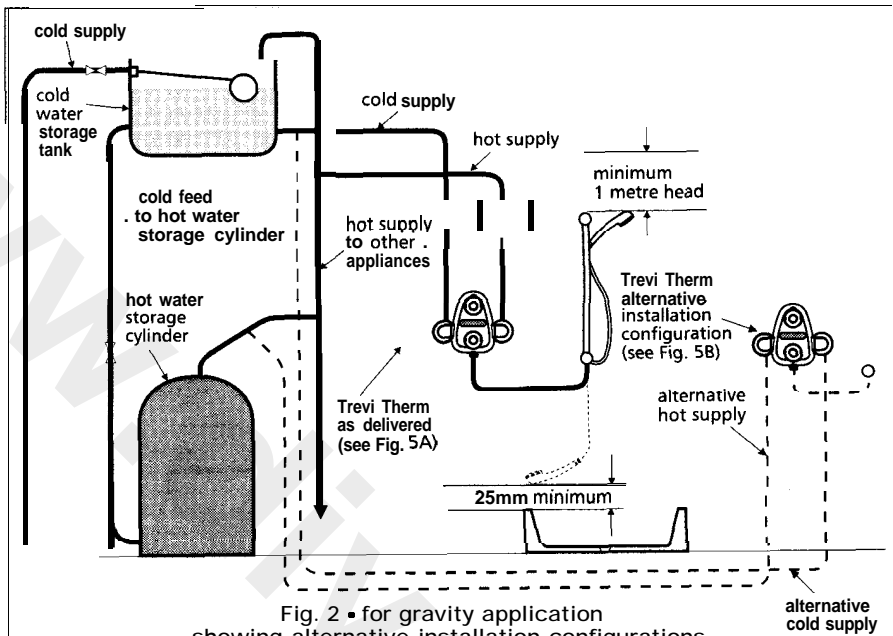
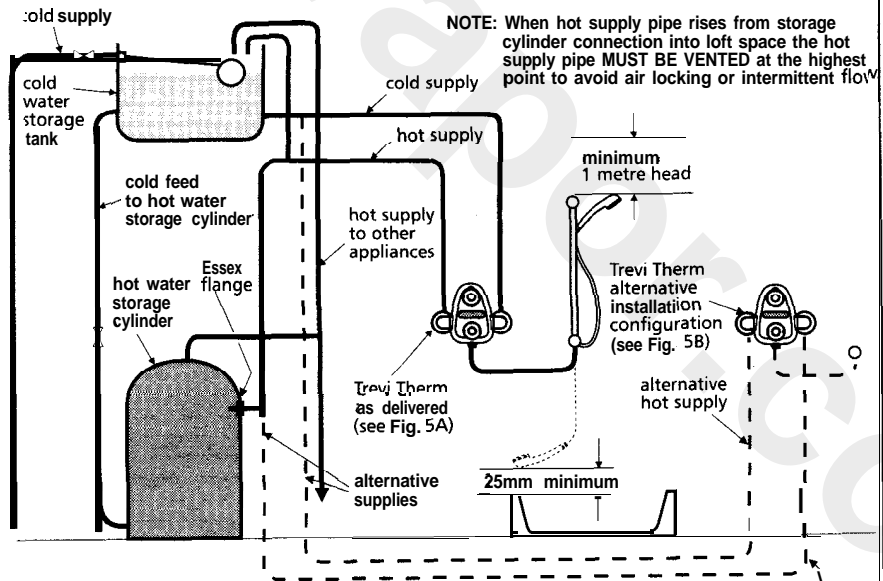

Fig. 2 - for gravity application
- showing alternative installation configurations



NOTE: When hot supply pipe rises from storage cylinder connection into loft space the hot supply pipe MUST BE VENTED at the highest point to avoid air locking or intermittent flow

Fig. 3 - for gravity application
- showing alternative installation configurations and alternative storage cylinder connections

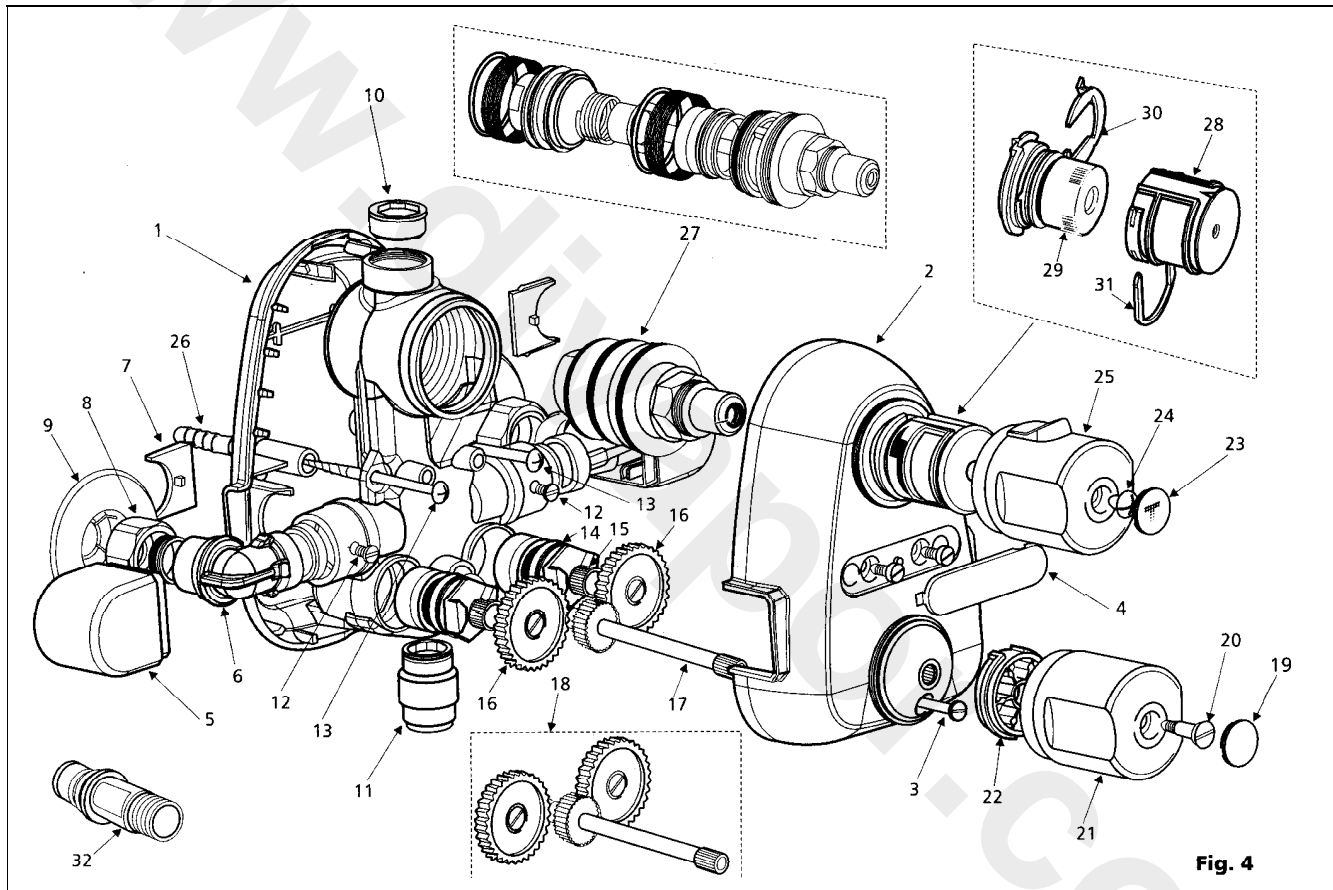

Fig. 4

Part Nos	Description
1	Rear cover plate
2	Front cover plate
3.	Cover plate fixing screw
4.	Cover access plate
5	Elbow cover
6	Compression elbow - 90° x 15mm
7	Elbow cover plate
8	Nut
9	Escutcheon ring
10	Blanking plug
11	$\frac{3}{4}$ " x $\frac{1}{2}$ " BSP shower outlet
12	Grub screw
13	Fixina screw
14	$\frac{1}{2}$ " cartridge
15	Cone screw
16	Clutch gears
17	Clutch drive shaft
18	Clutch complete
19	Cap for volume control handle
20	Screw for volume control handle
21	Volume control handle
22	Volume control handle carrier
23	Cap for temperature control handle
24	Screw for temperature control handle
25	Temperature control handle
26	Wall plug
27	Thermostatic control cartridge
28	Front handle carrier
29	Rear handle carrier
30	Fastening clip
31	'U' niece
32	Flushing outlet

GENERAL NOTES

The Trevi Therm thermostatic shower mixer is supplied for exposed installation. It can be installed with either concealed or surface mounted pipework and incorporates a means of flushing water through the pipework to remove debris, when the shower mixer is fitted on the wall and connected to supply pipework.

Flow control is by ceramic disc cartridges and there are no check valves used which may stick and restrict flow. The Trevi Therm shower mixer has been manufactured to be fitted in a variety of installation configurations to suit the shower room design, see Fig. 5.

Hot and cold connections are 15mm compression and the supply pipework should be 22mm copper tube, converting to 15mm close to the valve. Supplied with the shower mixer are two 90° x 15mm compression elbows (6 - Fig. 4) for connecting hot and cold supplies. The shower elbows are pre-fitted to accommodate return to wall pipework, although these are adjustable to cater for rising or falling supply pipework. Two decorative escutcheon rings are provided for return to wall pipework installation.

WATER SUPPLIES

The Trevi Therm exposed thermostatic shower mixer is designed for installation on normal UK low pressure

storage tank fed systems, unvented high pressure systems or modulating instantaneous water heaters and combi boilers. They are also suitable for all pumped applications. It is recommended that hot and cold water supply pressures be reasonably balanced for both low pressure and unvented high pressure systems for optimum performance. The mixer will, however, operate at unequal pressures up to a ratio of 5 to 1.

The Trevi Therm shower mixer is designed to operate on supply pressures between 0.1 bar and 5.0 bar. The minimum pressure head of 0.1 bar (1 metre) is measured as shown in Fig. 2 & Fig. 3. Pressure head is measured as the vertical distance between the bottom of the cold water storage tank that feeds the hot and cold water supplies and the highest point on the shower spray head.

The temperature of the hot water must not exceed 90°C and as most people prefer to shower at approximately 40°C, the hot water storage cylinder temperature must be in excess of 40°C.

It is recommended that isolating valves be fitted to the hot and cold supply pipework feeding the mixer. They will allow the isolation of the mixer for maintenance purposes without shutting off the supply to other appliances.

BYELAWS INSTALLATION REQUIREMENTS

As the incorrect installation of water fittings may result in contravention of Water Byelaws requirements the following **INSTALLATION REQUIREMENTS AND NOTES (IRN)** are intended as guides to water undertakers and consumers. The IRN's relate to the Byelaws implemented by water undertakers from 1st January 1989.

For further information see "Water Supply Byelaws Guide" published by the Water Research Centre (International Book No. ISBN 1 870779 02 9).

The following IRN's apply to the Trevi Therm fitting listed.

No. 320 Trevi Therm Exposed MkII shower mixer -
IRN Nos. 101, 103, 109.

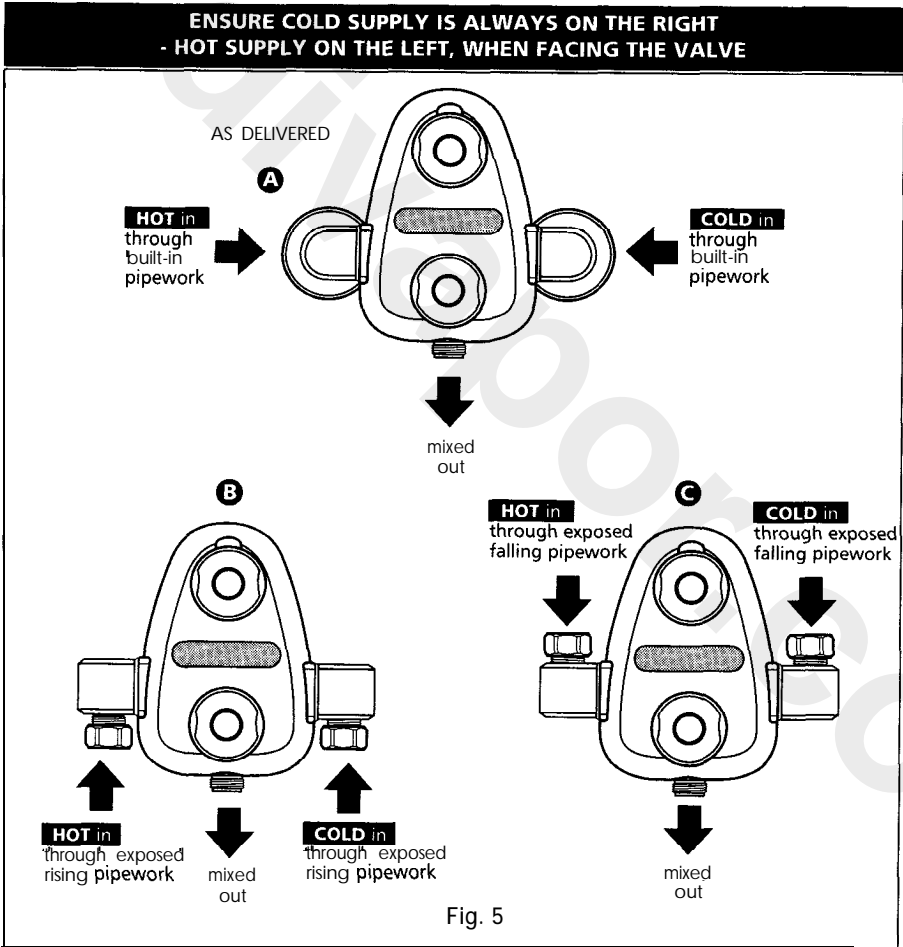

Before connecting the fitting to the supply pipework flush all pipework through with water. This will prevent the thermostatic control cartridge being clogged with debris.

1. The Trevi Therm exposed shower mixer is delivered ready for installation as Diagram A (Fig. 5) with the temperature handle at the top and the volume control at the bottom. The alternative configurations B and C are achieved by repositioning the compression elbows (6 - Fig. 4) to cater for rising or falling hot and cold supply pipework.

2. Decide on the configuration required and if either B or C (Fig. 5) are chosen, remove handles and front cover, remove elbow covers (5 - Fig. 4). Release grub screws (12 - Fig. 4) and rotate compression elbows to position required.

Tighten grub screws. Remove cover access plate (4 - Fig. 4). Connect fitting to the pipework, place fitting on the wall and mark position of screw holes for fixing screws (13 - Fig. 4).

Disconnect fitting, add escutcheon rings (9 - Fig. 4) to hot and cold pipework (built-in supply pipework only) and drill and plug wall. Screw fitting to the wall and refit cover access plate (4 - Fig. 4).

FLUSHING OPERATION

3. If necessary water may now be flushed through the pipework to prevent the thermal element in the thermostatic control cartridge being clogged with debris, once the shower

has been fitted see Fig. 6. Ensure that both cartridges (14) are closed before flushing out by turning the volume control handle (21) clockwise. Remove the volume control handle and the volume control handle carrier (22). Remove the fixing screws (3) and take off the front cover plate (2).

4. Pull out clutch drive shaft (17) and loosen cone screws (15) to release clutch gears (16). Lift off both clutch gears.

5. Remove one cartridge (14) by unscrewing anti-clockwise and insert flushing outlet (32), with drain tube attached (Fig. 7) use shower hose if necessary. Flush system, replace cartridge and repeat operation with the other cartridge. Both cartridges should be in the closed position when replaced in the mixer body.

6. Replace both clutch gears (16) with the flat side facing downwards, and secure with cone screws (15). Replace clutch drive shaft (17). Replace front cover (2). Replace volume control handle carrier (22) and volume control handle (21). Turn volume control handle (21) through 360° to synchronise the hot and cold cartridges. The volume control handle incorporates a slipping clutch to prevent damage in the event of being over tightened.

7. Turn on water supplies, check for leaks and operate the volume control handle.

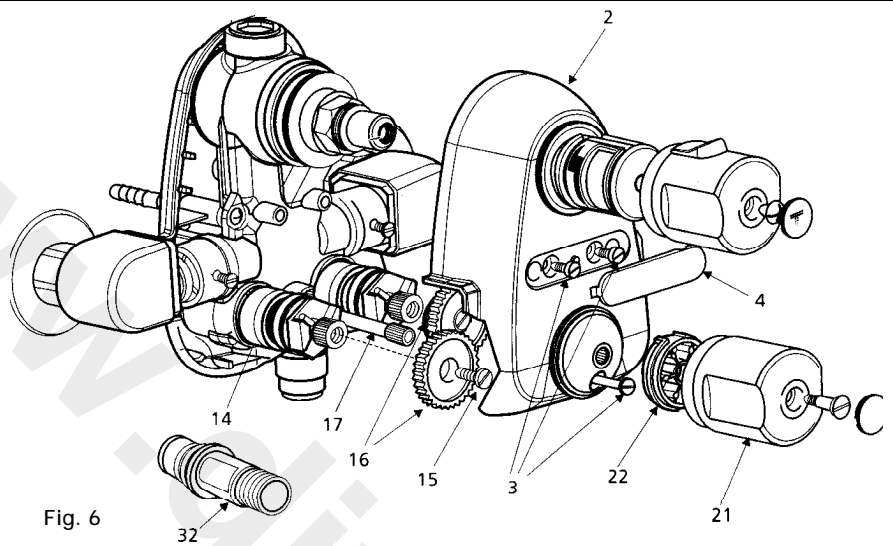

Remove cartridge
 Insert flushing outlet (32)
 and drain tube
 (not supplied) and flush
 supply pipe.
 Replace cartridge
 and repeat

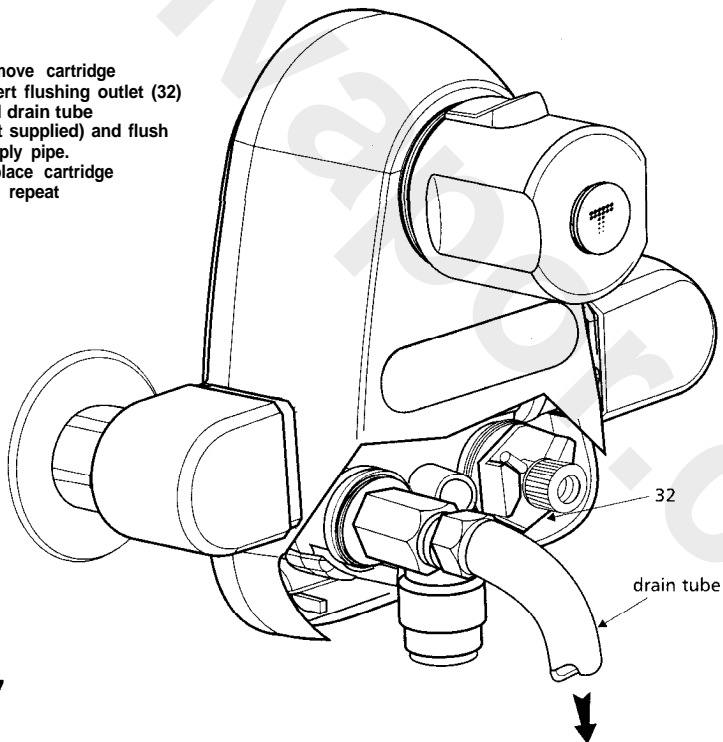

CALIBRATION

The thermostatic cartridge is pre-calibrated incorporating a safety stop at 40°C. To operate the shower at temperatures above 40°C, pull back red button on thermostatic handle and rotate anti-clockwise.

In the event of the thermostatic cartridge requiring re-calibration the following procedure should be undertaken, see Fig.8.

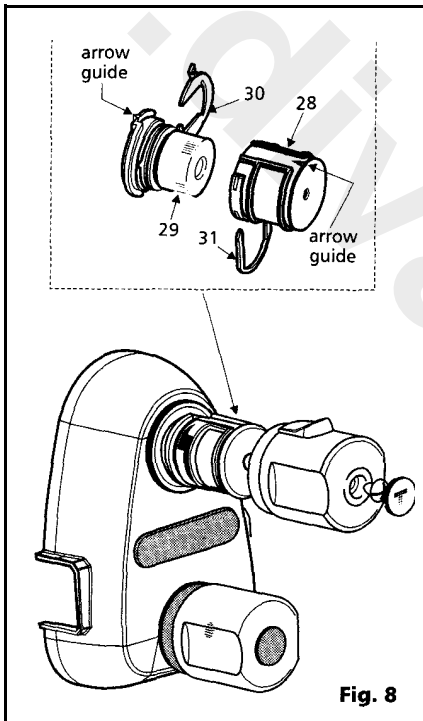

Fig. 8

1. Remove Trevi logo button and disconnect handle ensuring that the red button (40°C) is positioned at 12 o'clock.

2. Disconnect front handle carrier by removing red 'U' piece (31) exposing temperature control mechanism (29).

3. Turn on shower, position thermometer into running water and rotate temperature control mechanism until 40°C is achieved.

4. Reconnect front handle carrier (28) ensuring that arrow guide is at 12 o'clock - refit red 'U' piece (31), temperature handle and logo button.

SAFETY FOR THE USER

The Trevi Therm mixer is thermostatically controlled but outlet temperature depends on the position of the temperature control handle particularly if the red button has been operated.

Before using the shower check that the temperature is satisfactory.

Young children, the elderly and infirm should be supervised when using a shower.

OPERATION

Ceramic disc cartridges control the flow of hot and cold water. Turn the volume control handle through 180° to move from fully off to fully on. The temperature control handle will not move to provide a water temperature above 40°C without pulling back the red button. Temperatures up to 60°C are then available.

MAINTENANCE

Ceramic disc cartridges

The unique ceramic disc cartridges contain ultra smooth ceramic discs. They are so hard that they always remain sealed together polishing one another in use, and sand, sediment or other water borne matter cannot get between them or damage them.

Even the hardest water has no effect and this means that the Trevi Therm shower mixer should give many years of trouble free service without the drip and liming-up problems associated with traditional shower valves.

Cartridges are supplied in sets and both cartridges should be changed at the same time. They both operate in the same direction therefore they can be fitted to either side.

Poor flow can also be caused by a blockage of pipework debris in the thermostatic control cartridge.

In the event of poor flow or water temperature check the thermostatic control cartridge (27 - Fig. 4). The filter screens could be clogged and require cleaning. Remove the cartridge and carefully wash under a tap.

Spares

Spare components and replacement cartridges are available from Trevi Showers stockists. If you have any difficulty in obtaining spares locally, please contact Trevi Showers, The Bathroom Works, National Avenue, Kingston upon Hull HU5 4HS.

Any information reproduced from the Water Research Centre - "Water Fittings and Materials Directory" is with the kind permission of the WRc Water Byelaws Advisory Service.

www.divaport.com

TDA 847/796/965439



TREVISHOWERS

**Trevi Showers,
The Bathroom Works,
National Avenue,
Kingston upon Hull,
HU5 4HS, England.
Telephone: (01482) 470788.
Telefax: (01482) 445886.**

CUSTOMER CARE HELPLINE

01482 499380

Trevi Showers pursues a policy of continuing improvement in design and performance of its products. The right is therefore, reserved to vary specification without notice.

Trevi Showers is a division of Ideal-Standard Limited.

Trevi is a trademark of Ideal-Standard Limited.

A Division of American Standard (UK) Co.

TS29 6/96