



## TREVI CTV

CONCENTRIC  
THERMOSTATIC SHOWER VALVES



**Installation Instructions**  
**A3085 Trevi CTV Built-in (long handle)**  
**A3097 Outline CTV Built-in**  
**A3101 Trevi CTV Exposed**  
**A3102 Trevi CTV Built-in**

INSTALLER: After installation please pass this instruction booklet to user

**This installation instruction covers two types of Concentric Thermostatic Valves (CTV) - built-in and exposed**

**The Trevi built-in (A3102 & A3085) and Outline built-in A3097 are designed to be recessed in the wall.**

**The exposed (A3101) is designed to be surface mounted with either concealed or exposed pipe work.**

Both types are supplied with separate servicing valves incorporating strainers which must be positioned in the supply pipes in an accessible position so that the strainers can be cleaned on a regular basis.

#### Water Supplies and Water Regulations Requirements

The Trevi CTV is designed to be installed on normal UK low pressure storage tank fed systems, unvented high pressure systems or modulating instantaneous water heaters or modulating combination (combi) boilers. They are suitable for all pumped applications. Hot and cold water supply pressures must be reasonably balanced and from a common source - both from storage or both from a supply pipe. (IRN 101). The mixer will function within specification on unequal pressures up to 5 : 1 but it is not recommended that cold be connected to the rising main and hot to the tank fed supply as the pressure differential is likely to exceed the 5:1 ratio.

The minimum pressure for correct operation is 0.1 bar (1m head when measured as shown in Figure 5). Pressure head is measured as the vertical distance between the bottom of the cold water storage tank which feeds the hot water system and the highest point on the shower head.

When installing with a shower pump the use of a secondary tapping from the cylinder is highly recommended. Figure 1 shows the various methods of connecting the hot water pipe to the cylinder, the most preferred on the left and the least preferred on the right.

Flow control utilises a simple screw down rubber valve located downstream of the thermostatic mixer.

The hot and cold inlets, therefore, incorporate check valves. This is a regulatory requirement to prevent cross flow between the hot and cold supplies through the thermostatic element of the fitting.

The exposed version incorporates adjustable inlet elbows which can be turned backwards to receive supplies from within the wall. The centres between the inlets are adjustable between 147mm and 155 mm. The elbows can also be turned upwards or downwards to connect to falling or rising surface pipework.

The fitting is to be so installed as to be readily accessible for examination, repair, replacement or operation. (IRN 111).

#### For Healthcare Establishments (A3101 & A3102 only)

In accordance to NHS model engineering specifications DO8 the valve has approval for the following applications:-

High pressure - HP -S

Low pressure - LP -S

TMV3 approval number: - ETC/151/1101

*For this type of application the following supply conditions must apply:*

**Table 1 Conditions for normal use**

Operating pressure range	High pressure	Low pressure
Maximum static pressure - Bar	10	10
Flow pressure hot and cold - Bar	1 to 5	0.2 to 1
Hot supply temperature °C	52 to 65	52 to 65
Cold supply temperature °C	5 to 20	5 to 20
Temperature differential characteristic (TDC) °C	10	10

Note: Valves operating outside of these conditions cannot be guaranteed to perform as type 3.

**Approval only applies when the valves are installed without the flow restrictors illustrated in Figure 2**

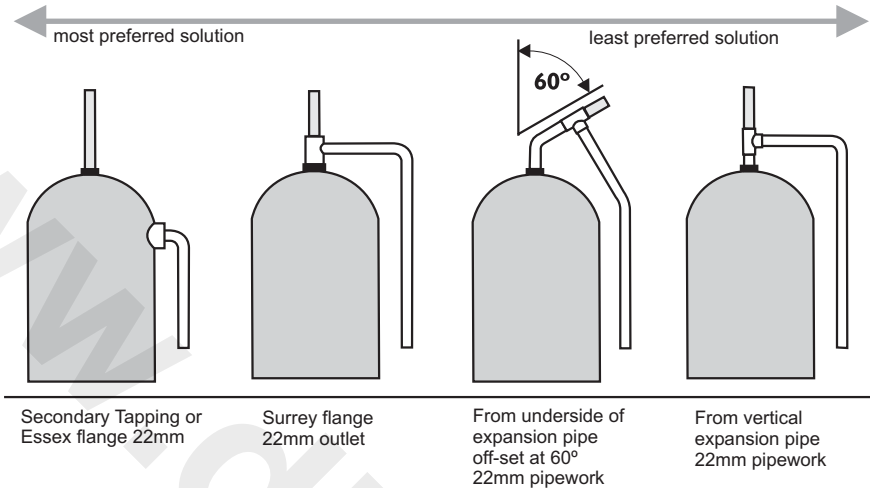
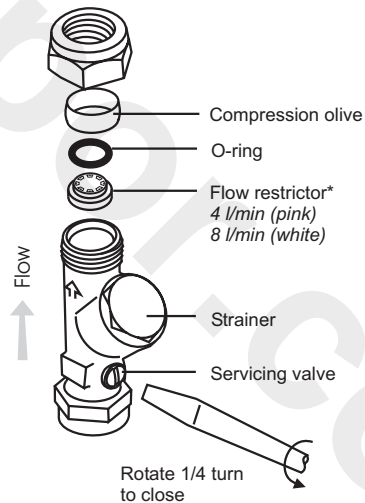

**Figure 1 Preferred location of cylinder tapping**

The temperature of the hot water must not exceed 85°C but the installer's attention is drawn to code of practice BS 6700 which recommends that stored hot water should normally never exceed 65°C. For correct operation of the valve, a minimum of 52°C is required.

When installing on a modulating combination boiler it is sometimes possible for the interaction of a thermostatic valve with the combi to cause the boiler to cut out and cut in again with the result that the water will become alternatively cold and hot. To overcome this it is necessary to fit the flow restrictors\* supplied upstream of the CTV. When installing on a combi boiler system these should be inserted in the downstream side of the servicing valve as shown on Fig 2. It is essential that these are positioned the right way round as shown in the sketch. Remove the compression nut and olive from the outlet side of the Isolating valve and place the restrictor in the outlet. Push to the bottom of the recess. Fit O-ring in

the visible rebate around the edge of the restrictor and push home until it is fully in the rebate. Use the tip of a small screwdriver or similar to achieve this.



**Figure 2 In-line filter and service valve showing restrictor**

\* The D08 approval of fitting only applies when installed without the flow restrictors

The water regulations published in 1999\* take a new approach to backflow in that they look at different categories of risk. The installer must assess the risk from the various categories of fluid in adjacent appliances before determining the level of backflow protection required for a particular installation. The following diagrams outline the protection required in various installations.

#### CATEGORY 3 RISK

Water in a shower tray, basin or bathtub is considered to be a fluid category 3 risk which is a fluid which represents a slight health

hazard if it were to find its way back into the supply pipe. For this reason it must not be possible for any flexible shower head to be able to enter any adjacent washbasin, bath or shower tray unless appropriate protection is employed. (See Figure 3). If it is desired to allow the handspray to be used inside say a bathtub or a basin it is essential that additional check valves be fitted to the inlet on both hot and cold supplies to the CTV. Alternatively an additional check valve should be fitted in the valve outlet.

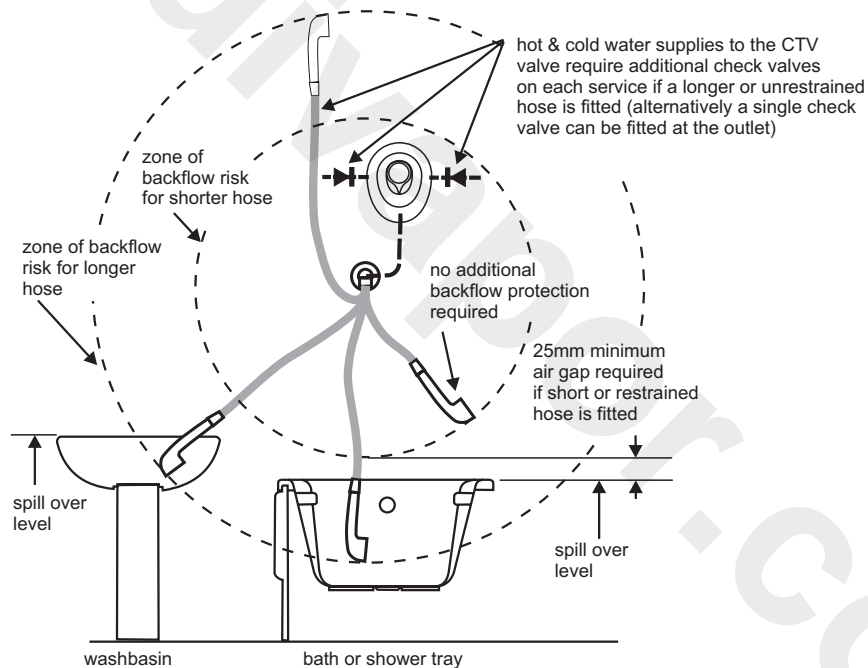

Fig 3 Illustration of backflow risk from a fluid Category 3

\*A guide to the Water Supply (Water fittings) Regulations 1999 and the Water Byelaws 2000, Scotland is published by WRAS (Water Regulations Advisory Scheme) Fern Close, Pen-y-Fan Industrial Estate, Oakdale, Newport, Np11 3EH. ISBN 0-9539708-0-9

**CATEGORY 5 RISK**

Water in a Sink, WC or Bidet is considered to be a fluid category 5 risk which is a fluid which represents a serious health hazard if it were to find its way back into the supply pipe. For this reason it must not be possible for any flexible shower head to be able to enter any adjacent Sink, WC or Bidet. If the flexible hose to be fitted could reach into any such vessel, the requirements to the system design are so onerous it is better not to fit a flexible. Rather, a fixed overhead showerhead should be considered. (See Figure 4). It will also be seen that this risk could change should the

hose be taken out of the restraining device or should a longer replacement hose be fitted at a later date. Installers and householders are advised to take account of these factors when fitting replacement hoses.

For pumped applications the pipe supplying the pump must not in addition supply an ascending spray bidet.

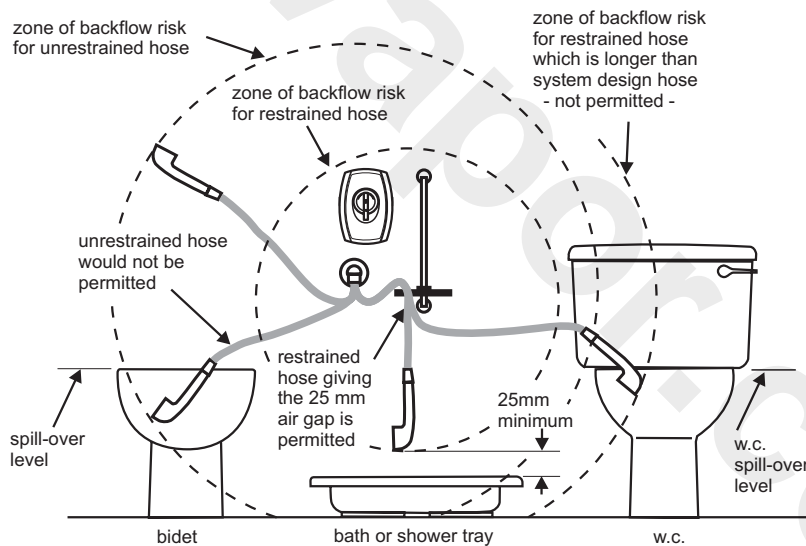

**Fig 4 Illustration of backflow risk from a fluid Category 5**

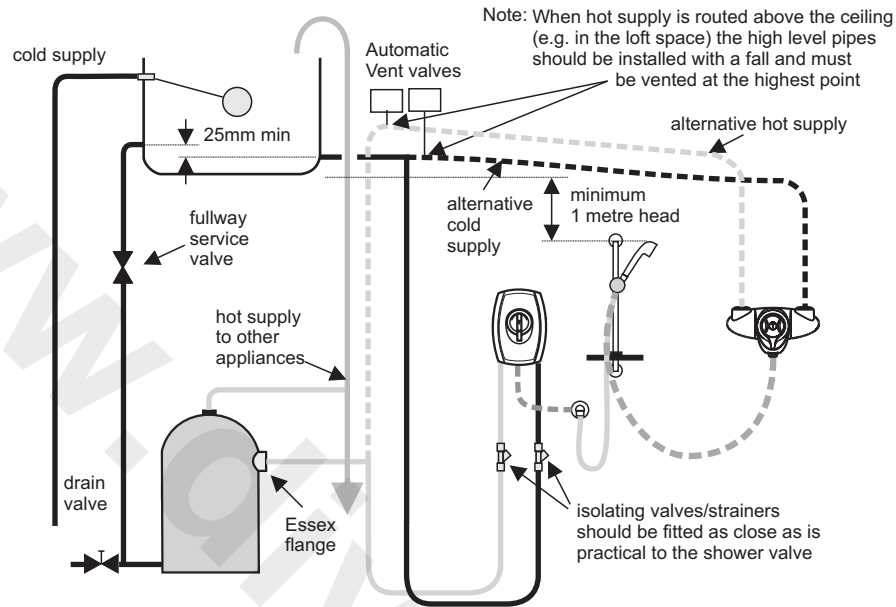

Figure 5 Recommended system layout for gravity applications

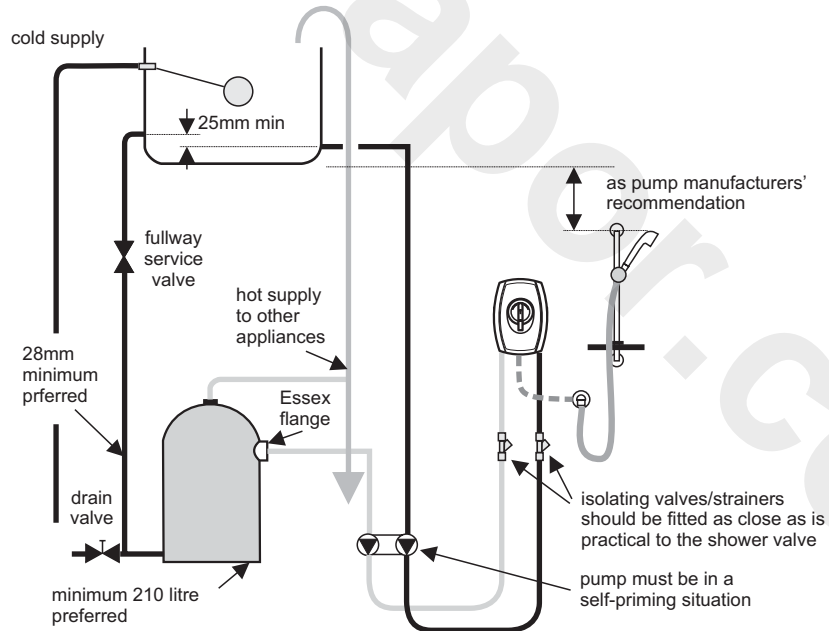

Figure 6 Recommended Pumped system layout

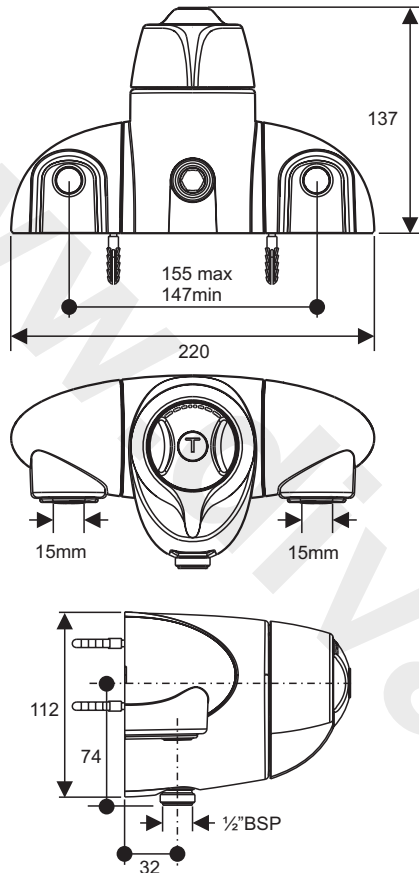

Figure 7 A3101 - Exposed CTV

**BUILT-IN Solid wall installations**

The Trevi CTV is delivered ready to be installed with the plaster guard fitted. Attached to the rear of the valve body is a polystyrene moulding which acts as a stabilising bed when the body casting is secured in a chased recess in a solid wall. The depth of the recess should be measured from the finished wall surface to the rear of the polystyrene bed moulding. There is an adjustment of 20mm in the installation depth from 52.5mm minimum to 72.5mm maximum from the finished wall surface. Ensure valve body is level.

See Figure 9.

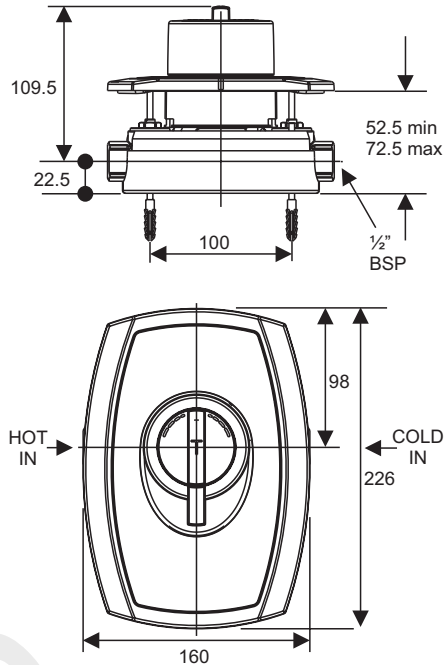
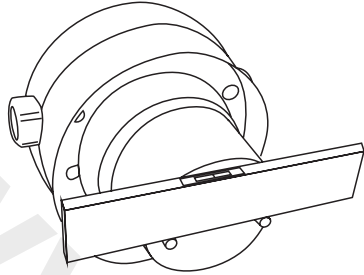

Figure 8 A3097 Outline CTV Built-in

The minimum and maximum depths are indicated on the mounting template / plaster guard. Connections to the built-in body are tapped 1/2" BSP and are marked HOT and COLD on the top of the brass body casting.

1. Chase out the wall for the mixer body and pipe work.
2. Connect the pipe work to the valve body.  
(Do not make any soldered joints near the valve body and ensure it is installed in vertical and horizontal alignment (Figure 9) to the wall surface and within the build-in depth limits.
3. Replace the plaster guard and complete the plastering/tiling work.
4. Remove the plaster guard when the plaster work is dry.
5. Fit the cover plate and trim.



**Figure 9**  
Using spirit level on plaster guard to ensure valve body is level when installing in chased out cavity in a solid wall.

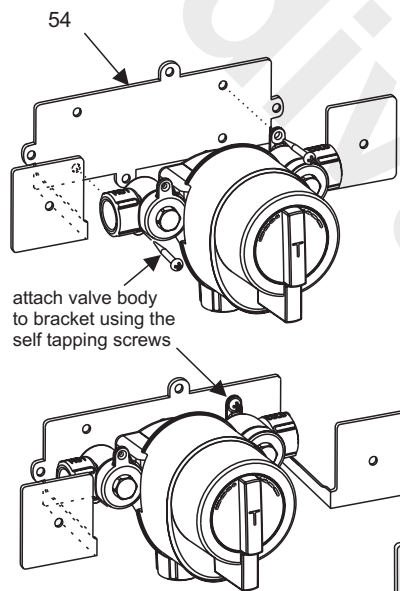

attach valve body to bracket using the self tapping screws

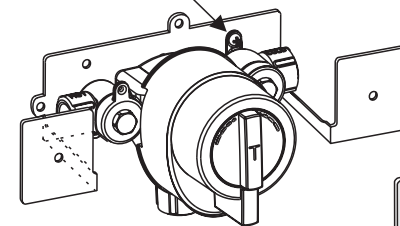

Tile over the bracket (which is only 1.5mm thick)

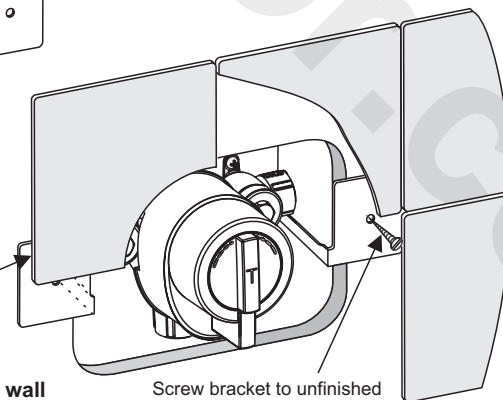

Screw bracket to unfinished wall surface using a suitable cavity fixing (not supplied)

### BUILT-IN Cavity partition walls

The normal method of installing in a cavity wall is to fit a wooden noggin between the wooden studs at a suitable depth to permit the back surface of the valve body to be screwed to its surface. The noggin should be set at a depth of 52.5 - 72.5 from the finished wall surface.

However, a metal mounting bracket may be the best method of mounting when installing built-in valves into walls of timber construction with large cavities and plasterboard facing. The bracket (# 54 - optional extra) will provide stability and ensure that the body is installed at the correct depth. See Figure 10.

As illustrated the bracket is shown for use with falling pipework. For rising pipework it should be rotated 180°.

The bracket is available from Trevi stockists or directly from Trevi Showers - contact 0870 129 6086 quoting part number L6714NU

After testing all the plumbing connections, make good the wall in the usual way. The tiles can simply be attached over the surface flange of the wall bracket as the bracket material at this point is only 1.5 mm thick.

**Figure 10** Fitting to a plasterboard wall using the fixation bracket

### INSTALLATION - EXPOSED VALVE

Connections to the exposed CTV are 15mm compression. Decide which configuration of pipe work is to be used. Adjust centres of the elbows (31) by screwing them in/out to the desired dimension. (These are adjustable between 147 mm and 155 mm). Connect the fitting (loosely at this stage as the cover slips still have to be fitted) to the pipe work. Red and blue stickers on the back plate indicate that hot is on the left and cold on the right. Mark the position of holes for fixing screws (32). Remove fitting from pipe work and drill and plug the wall. If installing with surface pipe work, fit the elbow cover pipe slips (4) to the pipes. Reconnect the fitting to the supplies. Screw fitting to wall and fit elbow covers (7) ensuring that the lugs on the pipe slips engage behind the cover (7).

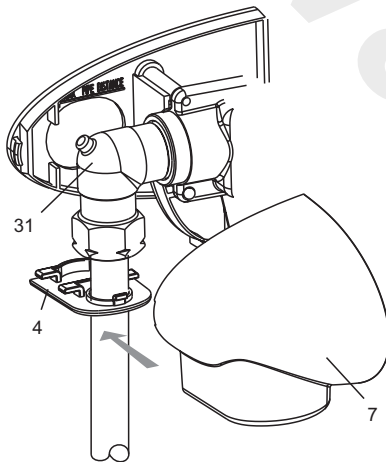

Figure 11 Fitting the cover slips

### CHECK VALVES

Because the flow control is down stream of the mixing valve the CTV is fitted with single check valves at the inlets. In a new installation if the valve is operated before the pipe work is flushed it is possible that debris from the installation can become lodged in the

check valve. To clean these proceed as follows.

**Built in.** After isolating the supplies, unscrew the cover (15) and withdraw the check valve module (22). Inspect and clean - Check that the check valve element (20) is working freely. Replace the module ensuring that the location stud engages in the recess in the brass body. Refit cover (15)

**Exposed.** Disconnect the supplies from the inlet elbows. Unscrew the inlet elbows and the check valves (20) will be found in the end of the elbows. Check and clean as above.

### FLUSHING OPERATION

**Warning** Do not open the flow control on the CTV before flushing the new pipework.

1. Ensure the flow control on the CTV is turned fully off (clockwise)
2. Turn the servicing valve to the off position, Figure 2.
3. Turn on the supply.
4. Remove the strainer.
5. Place a bucket under the open strainer port. Open the servicing valve and allow water to flow until it is clear of debris.
6. Refit the strainer and cover.
7. Repeat for the other supply.

### THERMOSTATIC CARTRIDGE REPLACEMENT

Remove handles (12 & 13) and wall plates (1 & 2) or covers (5, 6 & 7).

Remove the temperature handle carrier (21). To do this slide the black serrated lever (21a) in a clockwise direction with a screwdriver. Hold it there and pull off the handle carrier (21). Figure 12

Pull off the geared volume handle carrier (28). The thermostatic cartridge (19) can then be unscrewed.

Refit a thermostatic cartridge and replace the geared handle carrier (28).

To replace the flow control valve (18) loosen the screw in the end on the valve spindle and slide off the small gear wheel (17). Unscrew the flow control valve headwork and replace. Slide on the gear wheel (17) and tighten the screw. Turn the geared volume handle carrier (28) anticlockwise to close the valve and snap on the temperature handle carrier (21). Replace the wall plates (1 & 2) or covers (5,6 & 7).

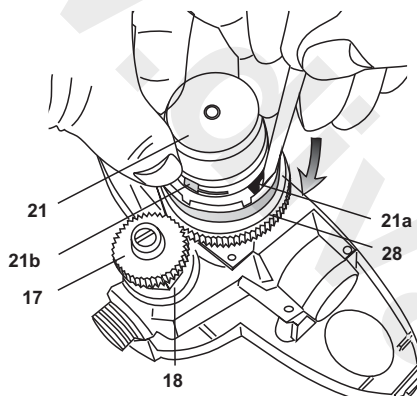
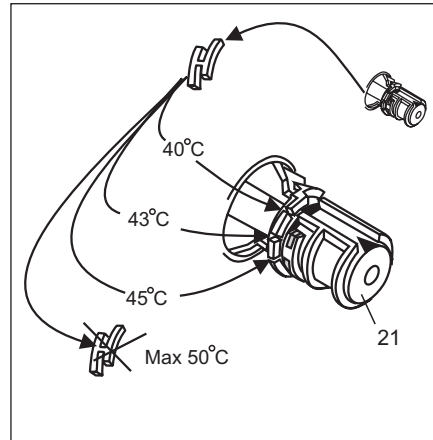

**Figure 12**  
Removal of temperature handle carrier

#### MAXIMUM TEMPERATURE STOP

The maximum mixed water temperature is factory set at 40°C. To change this temperature remove the temperature control handle (13). Remove the temperature limit stop (black H-shaped plastic part) and reinsert it in the appropriate recess on the handle carrier. Four different settings are possible. 40°C, 43°C, 45°C & 50 °C (See fig 13) Refit temperature handle (13). Refit temperature handle.

When installing in care homes it must not be possible to deliver water hotter than 41°C so the limit stop must remain at the 40°C setting.



**Figure 13**  
Adjusting the temperature stop

*Details of the recommended code of practice for safe water temperatures can be found on the Thermostatic Mixing Valve manufacturers Association web site: [www.tmva.org.uk](http://www.tmva.org.uk)*

#### CALIBRATION

Remove handles and wall plate or covers. Slide out the red "U" piece (21b Figure 12) and disconnect the handle carrier to expose the temperature control mechanism. Turn on the shower, position a thermometer in the running water and when the temperature settles, rotate the temperature control mechanism until 40 °C is achieved. Replace the handle carrier (21) ensuring the arrow is at 12 o'clock and refit the red "U" piece. Replace the covers and handles.

#### MAINTENANCE

The thermostatic cartridge seldom fails and the possibility of blocked filters should be investigated before contemplating replacing it. Although the CTV is supplied with strainers in the separate servicing valves,

small particles of debris may find their way past this and onto the filter screens in the thermostatic cartridge. These should be cleaned and re-fitted. See section on cartridge replacement. These shower valves have safety characteristics superior to the previous version of the Trevi CTV and are now approved to TMV 3 standard which allows them to be used in hospitals, nursing homes and residential care homes. (A3101/2 only) When installed in such establishments it is a requirement that the following commissioning and maintenance procedures be carried out. For normal domestic installations these checks are not a requirement.

#### COMMISSIONING AND PERIODIC CHECKS

The following procedure should be carried out after installation and every 6 months after to ensure that the valve is functioning correctly.

##### Check that:

1. The application of the thermostatic valve matches the approved designation.
2. The supply pressures are within the recommended range for the application.
3. The supply temperatures are within the permitted range for the application and comply with the guidance for prevention of Legionella.
4. The mixed temperature is as required for the application.

##### Record:

5. Each hot and cold supply. (Make a note of the measuring device used).
6. The mixed water temperature at the outlet device.

##### Isolate:

7. The cold supply to the mixing valve and record the mixed water temperature. The temperature should not exceed the value given in table 2 (following).

**Table 2**  
**A guide to maximum temperature sets**

Application	Mixed water temperature	Permitted maximum temperature rise during site testing
Shower	41°C	43°C

#### FREQUENCY OF REGULAR SERVICING

The purpose of servicing regularly is to monitor the performance of changes in system and valve set up. This may require the need to adjust either the supply system or the valve. The A3101/2 should be checked and tested 6 to 8 weeks and again 12 to 15 weeks after commissioning. The results are to be compared against original commissioning settings. If there is no significant change (i.e. less than 1°C ) then a 6 monthly servicing cycle may be adopted. If the temperature increases up to and greater than 2°C at the mixed water outlet, then servicing checks should be carried out more frequently, (every 4 months).

The following procedure is recommended for all servicing:

1. Repeat the procedure of recording and checking supply temperatures. (The same type of measuring equipment should be used).
2. If the temperature has changed significantly from the previously recorded valves, you should check the following:
  - a. All inline or integral valve filters are clear of obstruction.
  - b. All inline or integral check valves are clean and working properly to prevent backflow.
  - c. Any isolating valves are fully open.
3. When satisfied with the mixed outlet temperatures re-record the temperatures. If the change in temperature of the mixed water is extreme it is advisable to increase

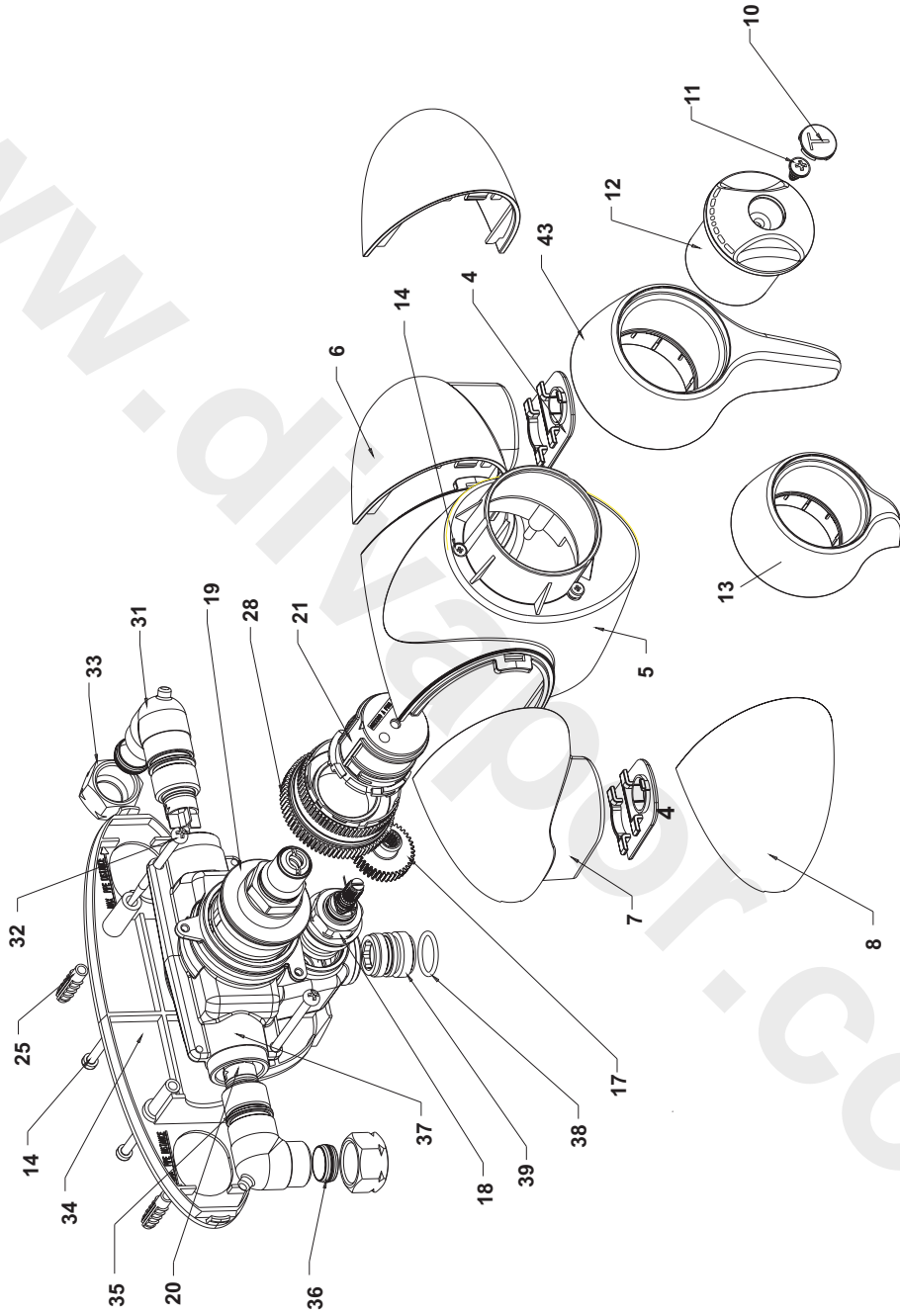

A3085 Trevi CTV Built-in with long handle

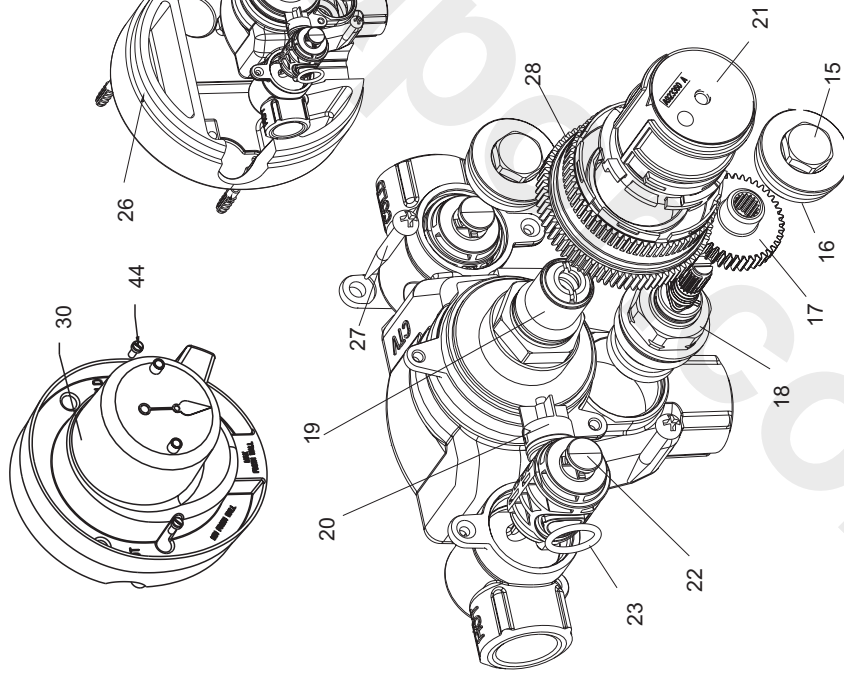

Outline CTV  
A3097

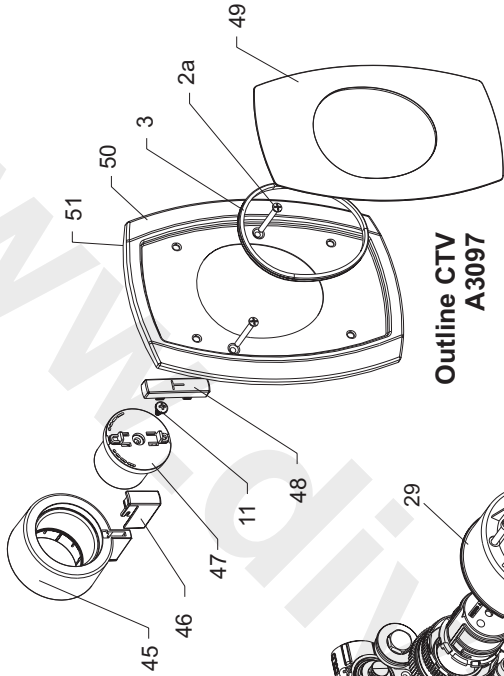

Trevi CTV with standard  
handle A3102

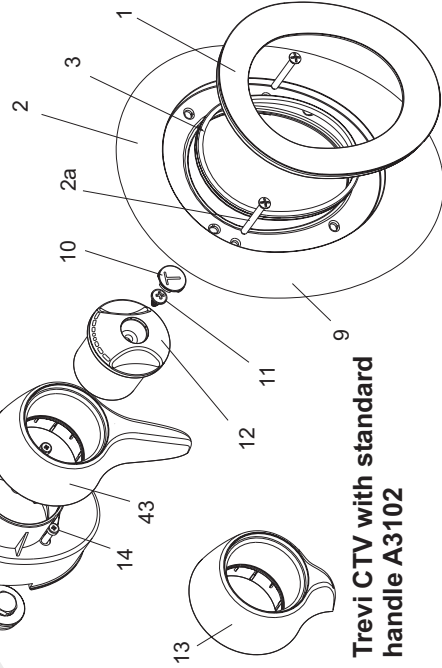

CTV Diagnostic Chart

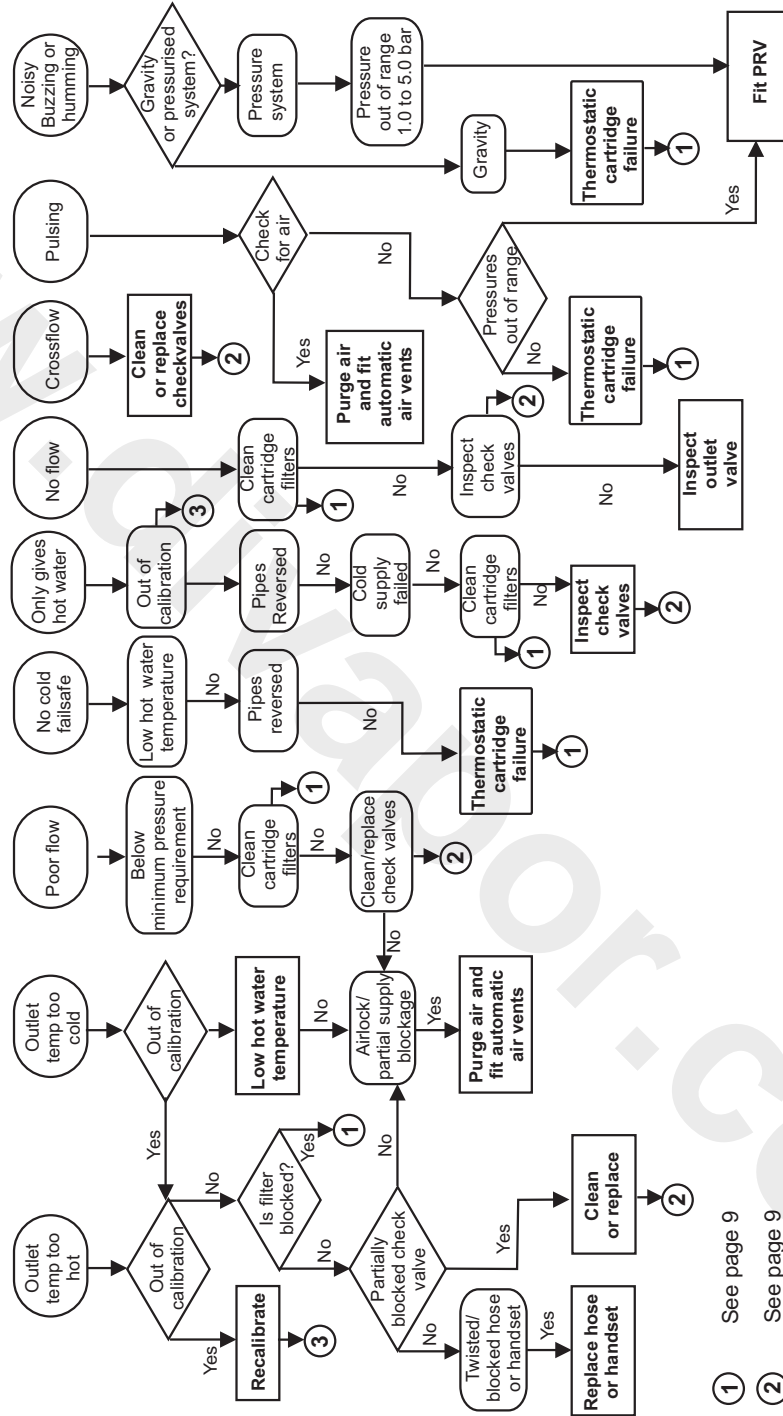

- ① See page 9
- ② See page 9
- ③ See page 10

Part No's	Description
1	Cover plate trim
3	Cover plate grommet
2	Cover plate
4	Elbow cover pipe slip
5	Exposed cover body
6	RH elbow cover (viewed pipe rising)
7	LH elbow cover (viewed pipe rising)
8	Back inlet elbow cover
9	Cover plate wall seal
10	Handle cover cap
11	Screw - temperature control handle
12	Temperature handle
13	Flow control handle (standard)
14	Screw
15	Check valve cover plug
16	O ring
17	Flow control drive gear
18	Flow control valve anti clockwise to close
19	Thermostatic control cartridge
20	Check valve
21	Temperature handle carrier
22	Check valve carrier
23	O ring
24	Body casting
25	Wall plug
26	Valve body stabilising bed polystyrene
27	Wall fixing screw
28	Volume handle geared carrier
29	Valve shroud
30	Plaster guard
31	Adjustable connecting elbow
32	Screw
33	½ " compression nut
34	Back plate
35	O ring
36	15mm compression olive
37	Main body casting finished
38	O ring
39	Outlet nipple
40	Wall elbow

Part No's	Description
41	Isolating valve/strainer/flow limiter (page 2)
42	Flow restrictor (page 2)
43	Flow control handle (long)
44	Plaster guard screw
45	Outline CTV flow control handle body
46	Outline CTV flow control handle lever
47	Outline CTV temperature knob body
48	Outline CTV temperature knob handle
49	Outline CTV BI front cover plate
50	Outline CTV BI back cover plate
51	Outline CTV BI cover plate seal
52	Flow regulator 4litre/min
53	Flow regulator 8litre/min
<b>Optional extra</b>	
54	Cavity wall mounting bracket # L6714NU

**The fittings covered by this installation and maintenance instruction should be installed in accordance with the water regulations published in 1999\*, therefore, American Standard would strongly recommend that these fittings are installed by a professional installer**



Trevi Showers  
The Bathroom Works  
National Avenue  
Kingston-upon-Hull  
HU5 4HS  
England

CUSTOMER CARE HELPLINE

**0870 129 6086**

CUSTOMER CARE FAX

**01482 499611**

E-MAIL

**ukcustcare@aseur.com**

Trevi Showers pursues a policy of continuing improvement in design and performance of its products.

The right is therefore reserved to vary specification without notice.

Trevi Showers is a division of  
American Standard Plumbing (UK) Ltd

TS085 09/03

E96518000