



Roca

ESSENTIAL 2.0

A2H0423000



INDICE

ES

1. INTRODUCCIÓN	3
2. DESCRIPCIÓN DEL EQUIPO	3
3. CONSIDERACIONES PREVIAS.....	3
4. MATERIAL NECESARIO PARA LA INSTALACIÓN DE LA COLUMNA	4
5. INSTALACIÓN DE LA COLUMNA.....	4
6. INSTRUCCIONES DE FUNCIONAMIENTO	10
6.1 PRECAUCIONES	10

EN

1. INTRODUCTION.....	5
2. DESCRIPTION OF THE EQUIPMENT	5
3. PRELIMINARIES	5
4. MATERIALS REQUIRED FOR INSTALLATION OF THE COLUMN.....	6
5. INSTALLATION OF THE COLUMN	6
6. OPERATING INSTRUCTIONS	11
6.1 WARNINGS	11

A2H0423000

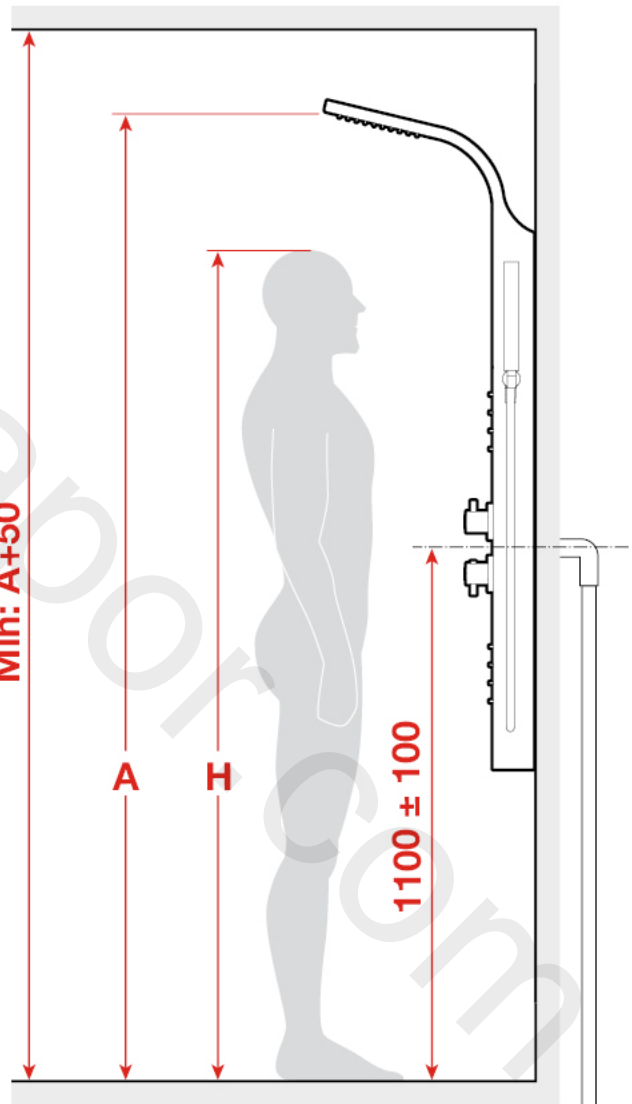
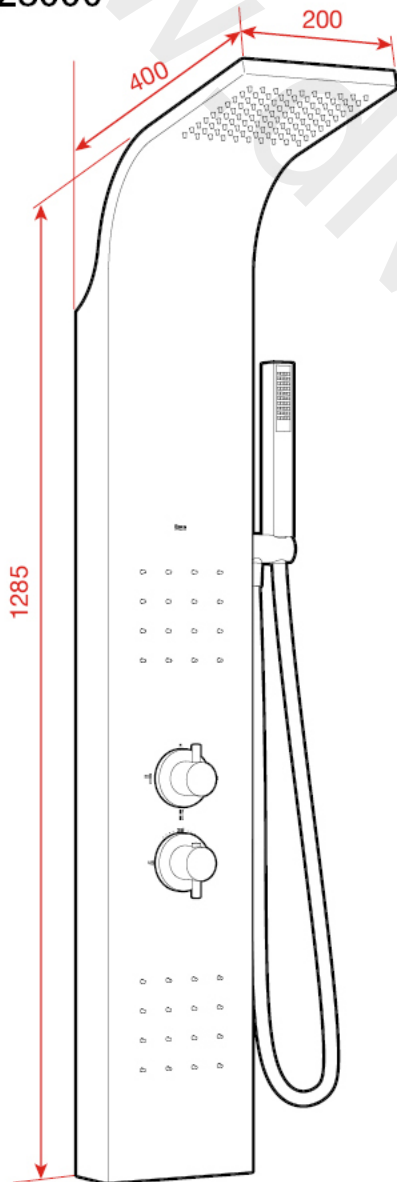

A	1900	2000	2100	2200	2300	 1100 min 1200 max
H	1700	1800	1900	2000	2100	

Dimensiones en milímetros
Measurements in millimeters

1. INTRODUCCIÓN

La instalación debe realizarse de acuerdo con la normativa vigente y un instalador autorizado, siguiendo las correspondientes instrucciones.

2. DESCRIPCIÓN DEL EQUIPO

Compruebe los elementos recibidos y el perfecto estado de las piezas antes de realizar la instalación.

Columna ESSENTIAL 2.0: 1 unid.

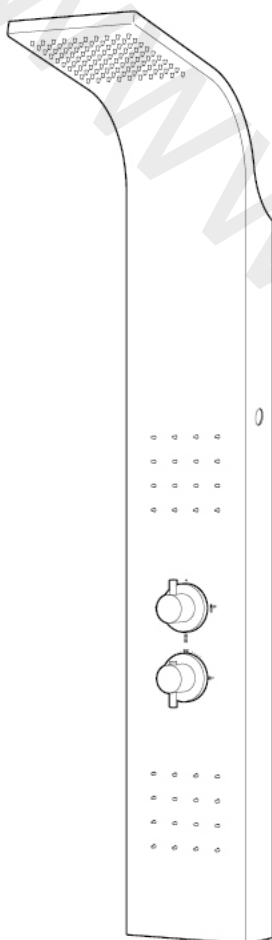

Caja de accesorios

x1	x1	x3	x3
x1	x2	x1	x1
x1	x1		

3. CONSIDERACIONES PREVIAS

Compruebe el espacio disponible antes de instalar la columna ESSENTIAL 2.0.

Es muy importante que previo al montaje verifique que la situación de las tuberías, está en el lugar adecuado.

	P	P bar			
	T	°C			
	Q	l/min			
	(3 bar)		14	12	9

Referente a la presión y temperatura del agua:

Presiones dinámicas inferiores a 1 bar no permiten una regulación correcta de la grifería.

Para presiones superiores a 5 bar, instale un reductor de presión tanto en el agua fría como en la caliente.

Depósitos acumuladores:

Para depósitos acumuladores inferiores a 100 litros se recomienda elevar el termostato hasta el máximo valor admisible, ya que en caso contrario la duración del hidromasaje con agua caliente quedará reducida a pocos minutos. Por cuestiones de seguridad este valor no deberá sobrepasar los 60° C.

Calentadores instantáneos:

Si se dispone de un calentador instantáneo o caldera mixta deben garantizar las presiones y consumos indicados anteriormente. Potencias útiles inferiores a 20.000 Kcal/hora no podrán mantener temperaturas elevadas durante determinadas funciones, registrándose una pérdida de caudal o de temperatura.

Si se le apaga la caldera y le sale agua fría, ajuste la temperatura y caudal de la caldera de forma adecuada, en caso de no conseguirlo consulte al servicio post-venta de la caldera.

Sistemas mixtos calentador instantáneo con depósito acumulador:

Es la configuración recomendada, con un volumen de depósito no inferior a 50 litros.

4. MATERIAL NECESARIO PARA LA INSTALACIÓN DE LA COLUMNA

5. INSTALACIÓN DE LA COLUMNA

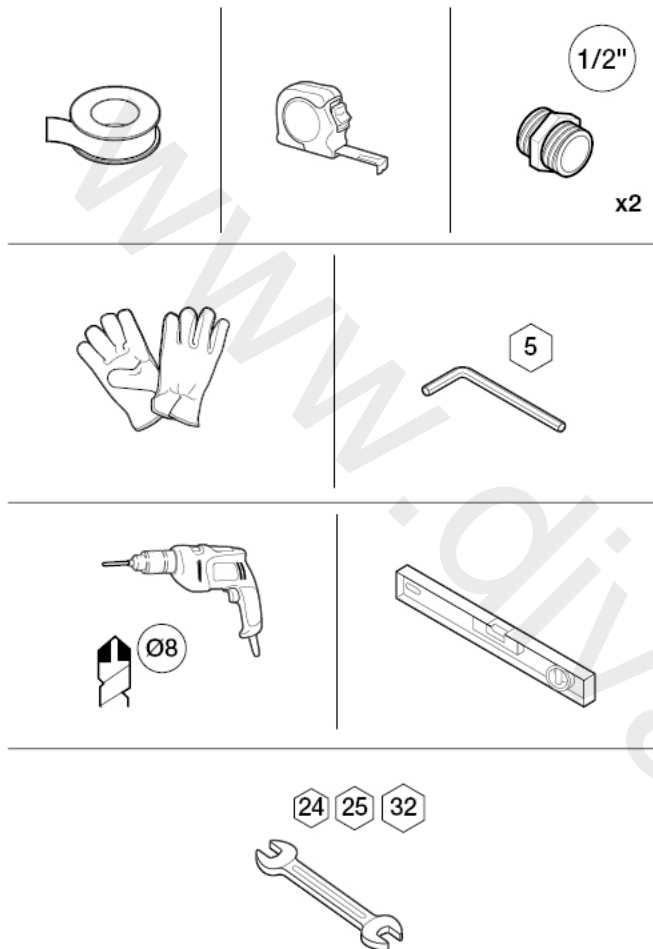

El montaje de la columna **ESSENTIAL 2.0** debe realizarse con las protecciones provistas en la columna. Se recomienda el uso de guantes antideslizantes.

Una vez instalada, quitar las protecciones.

Asegúrese de que no existen fugas de agua antes de proceder con el montaje de la columna.

Proceda con el montaje de la columna siguiendo los pasos que se detallan a continuación.

1. INTRODUCTION

The column must be installed in accordance with current standards and by a qualified fitter, following the corresponding instructions.

2. DESCRIPTION OF THE EQUIPMENT





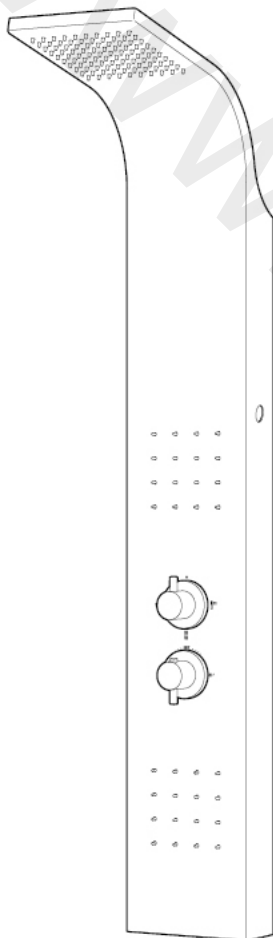





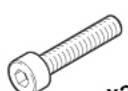

Please check that all parts have been received and are in perfect condition before beginning the installation.

ESSENTIAL 2.0: 1 unit.

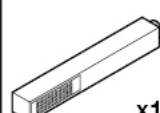

Fittings Box









EN

 x1	 x1	 x3	 x3
 x1	 x2	 x1	 x1
 x1	 x1	 x1	 x1

3. PRELIMINARIES

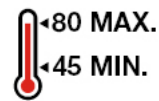
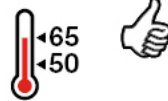
Check the space available before beginning the installation of the ESSENTIAL 2.0 ensemble.

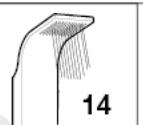
The water outlets from the plumbing system must be at the intended location.

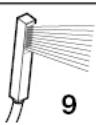
 P	P bar	 MAX. 10	 5 
 T	°C	 80 MAX. 45 MIN.	 65 50 
 Q (3 bar)	l/min	 14	 12  9

Concerning the water pressure and temperature:

Dynamic pressures lower than 1 bars will prevent the proper adjustment of the taps.

For pressures over 5 bars, install a pressure reducer in both the cold and hot water supplies.

Accumulator tanks:

For accumulator tanks below 100 litres it is recommended to increase the thermostat to the highest possible value, as the hot water hydro-massage will otherwise last only a few minutes. In the interests of safety this value must not exceed 60° C.

Instant heaters:

If an instant heater or mixed boiler is used, these must guarantee the aforementioned pressures and consumptions. Useful electrical powers below 20.000 Kcal/hour are not sufficient to maintain high temperatures during certain operations, which thus register a reduction of flow or temperature.

If the boiler is turned off and the water runs cold, adjust the temperature and flow of the boiler as appropriate and if this does not work, please consult the boiler's after-sales service.

Instant heater with accumulator tank mixed systems:

This is the recommended configuration, with a tank volume of no less than 50 litres.

4. MATERIALS REQUIRED FOR INSTALLATION OF THE COLUMN

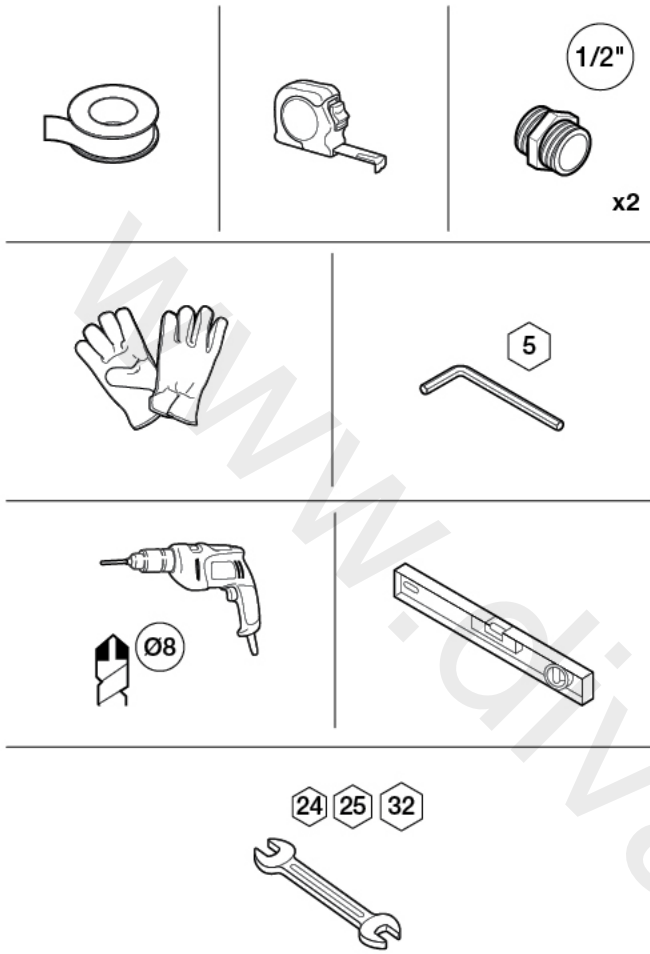

5. INSTALLATION OF THE COLUMN

The column assembly **ESSENTIAL 2.0** must be installed with the provided protections attached to the column. We recommend the use of anti-slip gloves.

Once installed, remove the protections.

To install the column, Ensure that there are no water leaks prior to installing the column.

Proceed with the column installation by following the steps outlined below.

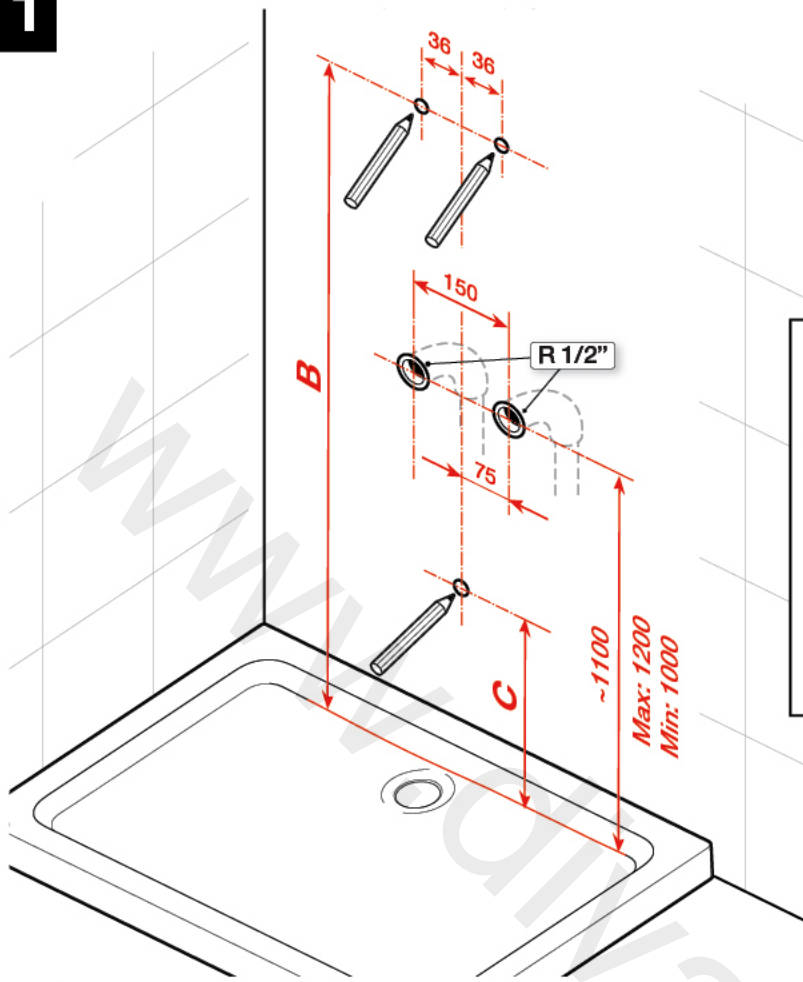
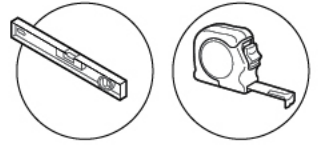
1

	H	B	C
	1700	1650	660
	1800	1750	760
	1900	1850	860
	2000	1950	960
	2100	2050	1060

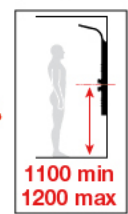
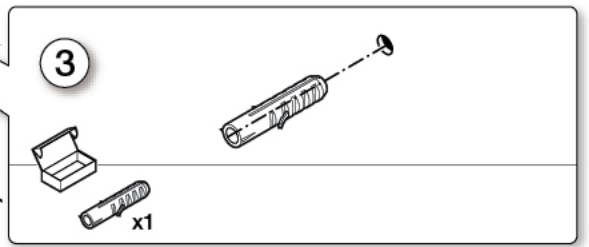
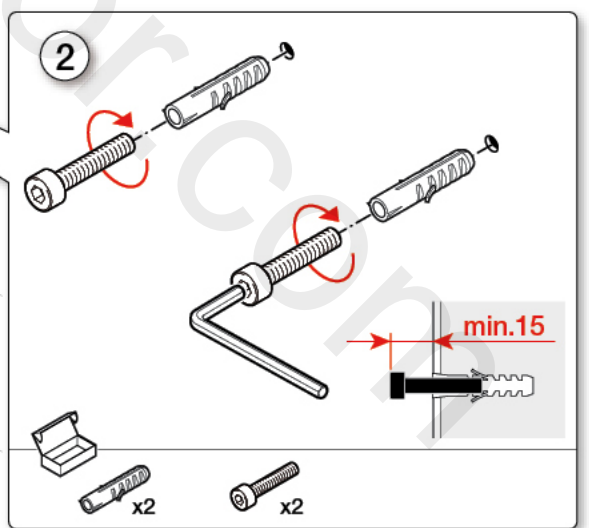
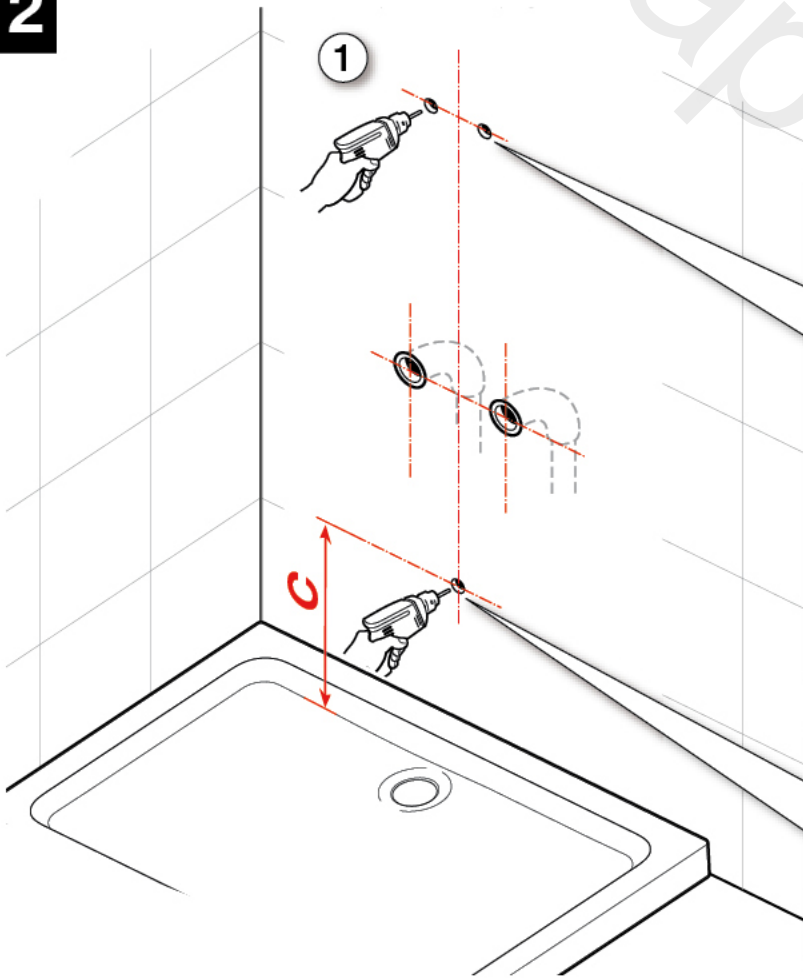
**2**

3

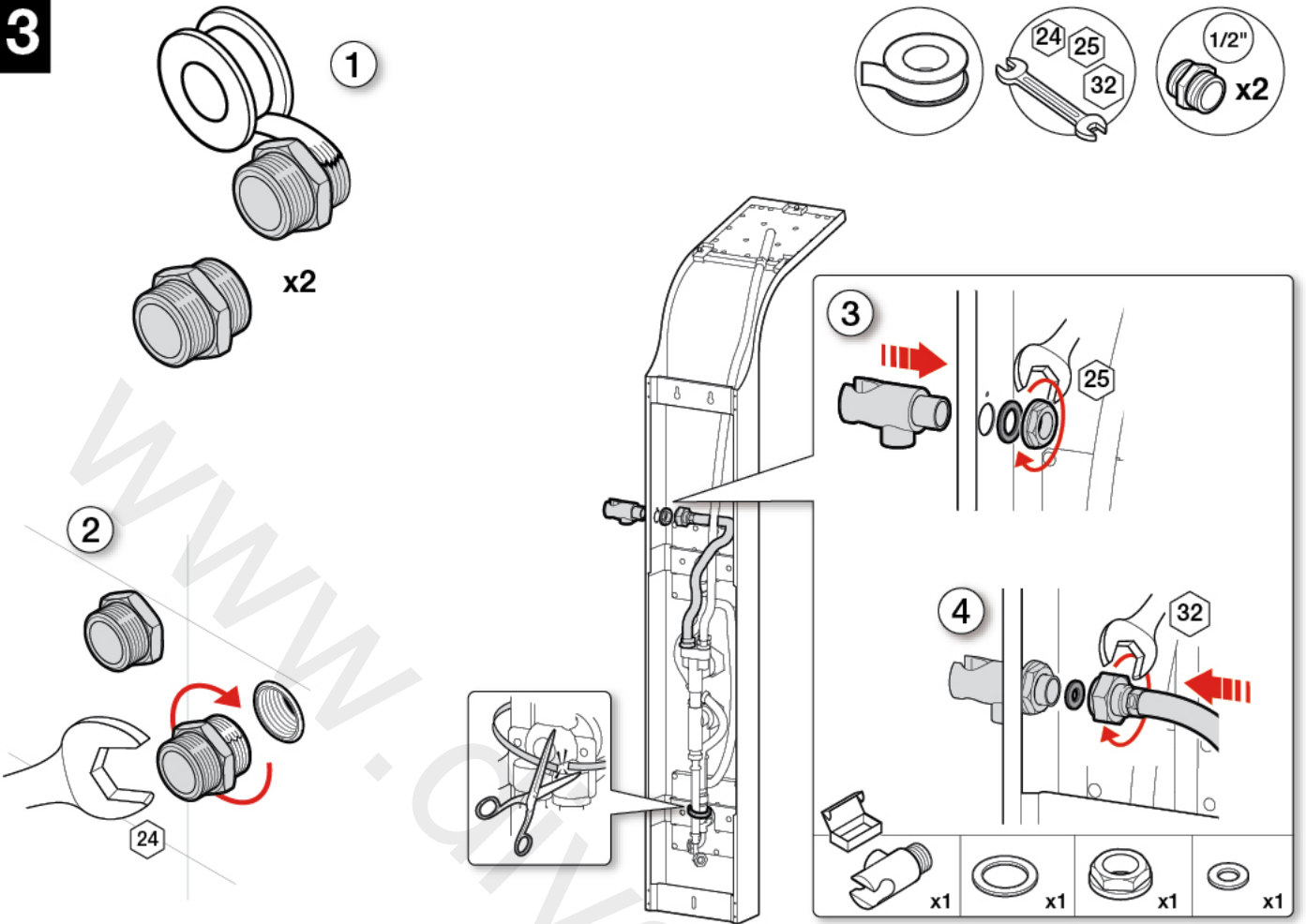

4

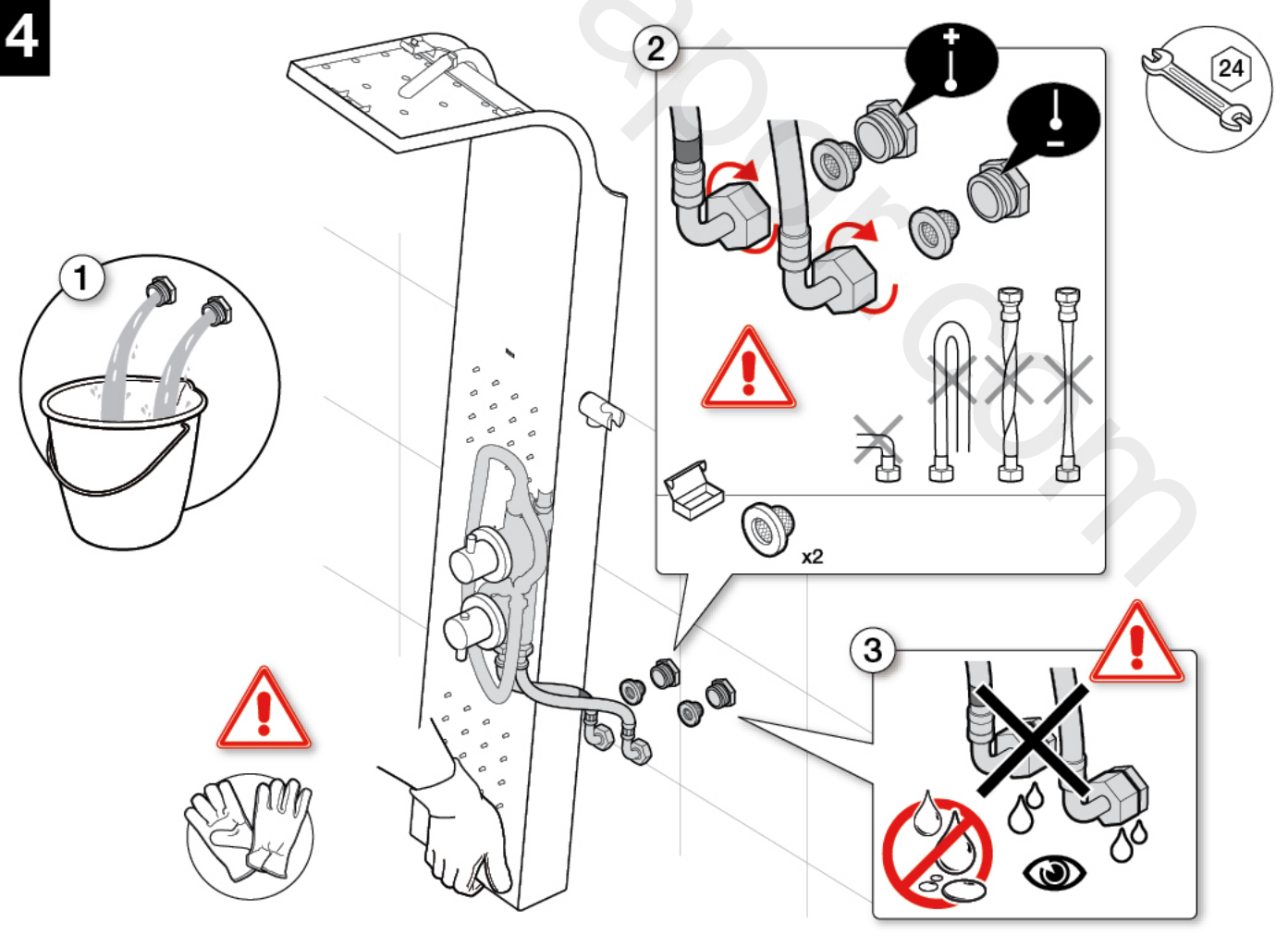

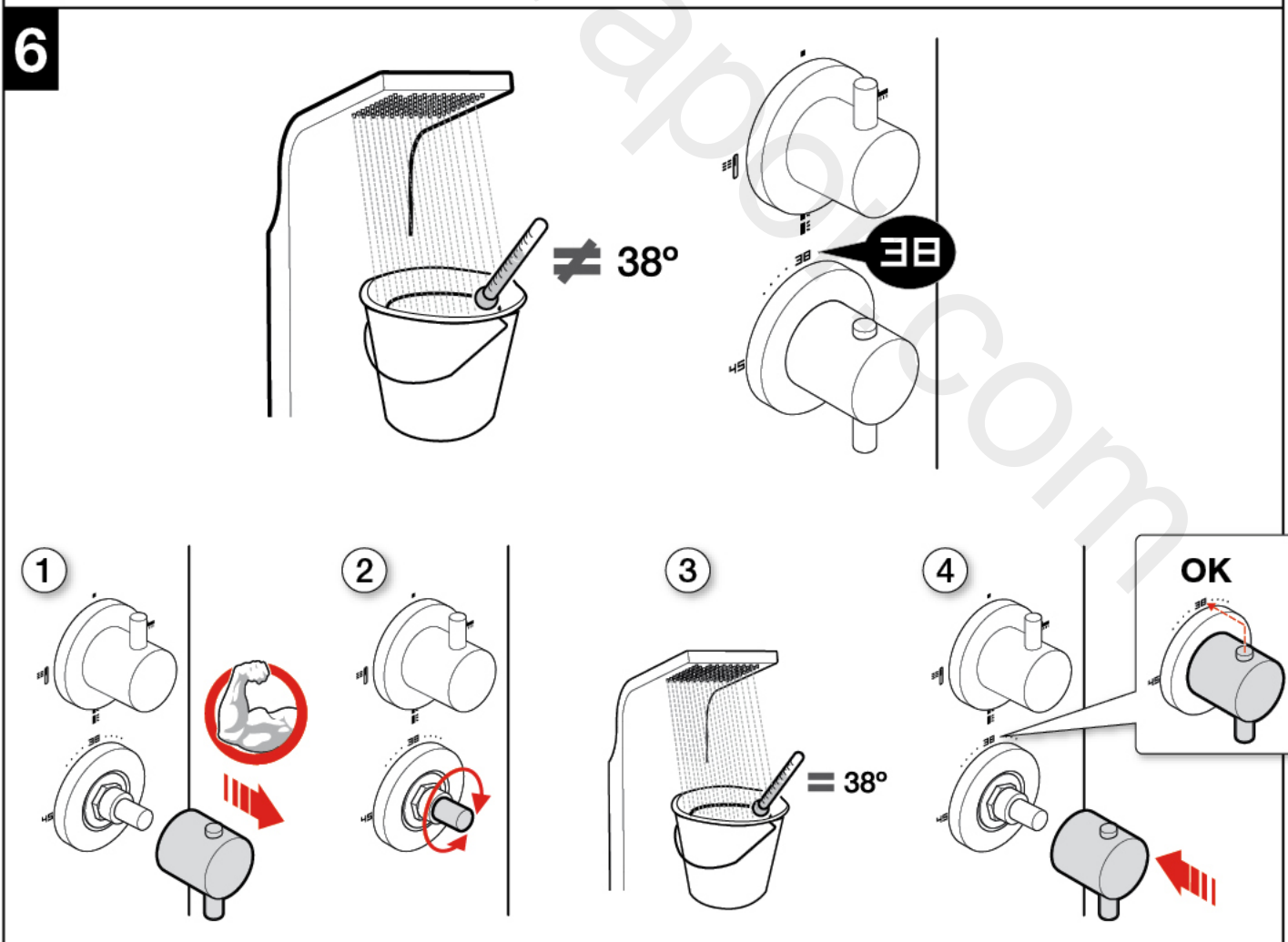
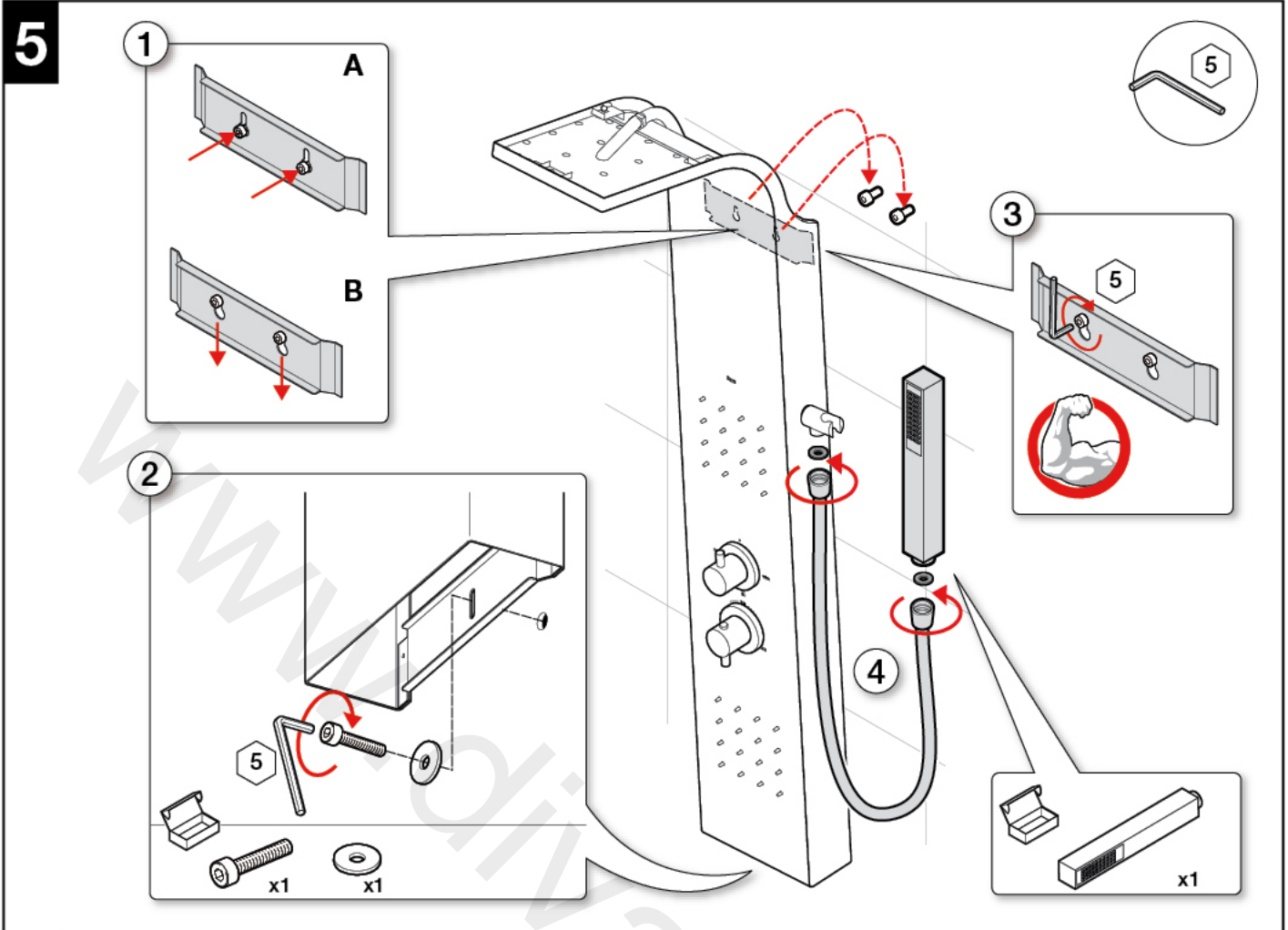



6. INSTRUCCIONES DE FUNCIONAMIENTO

A través del inversor de la columna de hidroterapia **ESSENTIAL 2.0** se le permite seleccionar las siguientes funciones:

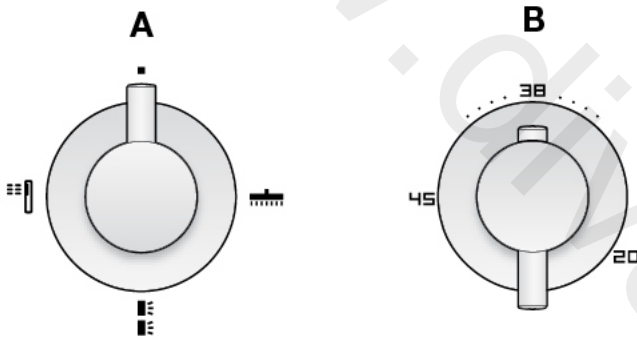
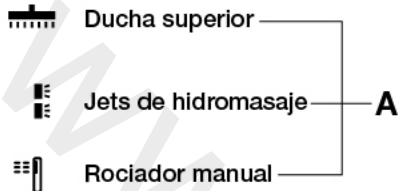

Para ello basta con girar el mando inversor **(A)** hacia la posición deseada, ya sea en un sentido u en otro. La combinación de varias funciones **(A)**, puede reducir el rendimiento de los rociadores en comparación con su uso individual.

El selector de temperatura permite seleccionar la temperatura deseada, girando el mando **(B)** a derecha ó izquierda. Por precaución, para temperaturas superiores a 38° C, es preciso pulsar el mando y girar a la izquierda.

6.1 LIMPIEZA DE LOS JETS

Cuando el agua que sale de los jets no va bien dirigida, se debe a la disposición de cal en los orificios de salida.

Para su limpieza, pasar la mano por los orificios de salida de silicona, con el agua accionada.

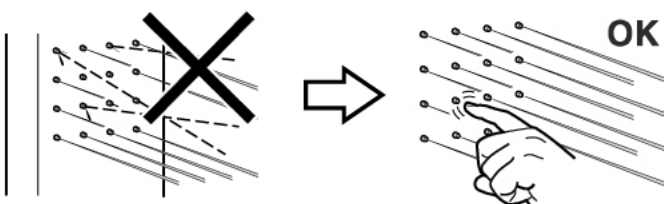

6.3 PRECAUCIONES

A pesar de los efectos terapéuticos preventivos y relajantes del hidromasaje, es importante señalar que en caso de afecciones agudas, cardiopatías descompensadas, hipertensiones graves, etc., así como para determinado tipo de personas (niños, ancianos, embarazadas), deben tenerse en cuenta unas condiciones especiales de duración, temperatura y frecuencia. En estas situaciones es recomendable la consulta previa al médico.

Evite colgar objetos en la columna, ya que ésta no está preparada para soportar peso adicional.



LIMPIEZA ACERO INOXIDABLE

Los aceros inoxidable resisten bien la corrosión, pero hay que seguir unas reglas muy estrictas de limpieza y mantenimiento para evitar deterioros de aspecto.

CONSEJOS DE LIMPIEZA GENERALES

1. Aplicar detergentes de tipo neutro previstos para éste campo de aplicación (tensioactivos no iónicos y ácido cítrico.)
2. Aplicar el detergente mediante un paño suave. Los paños abrasivos pueden rayar la superficie.
3. Aclarar con agua hasta eliminar completamente el detergente
4. Secar la columna con un paño suave.
5. Los residuos de productos de aseo, jabón líquido, champús, gel de baño....pueden dañar también la columna. Aclarar con abundante agua después de su uso.
6. Las manchas de cal pueden evitarse secando la columna con un paño suave después de uso.

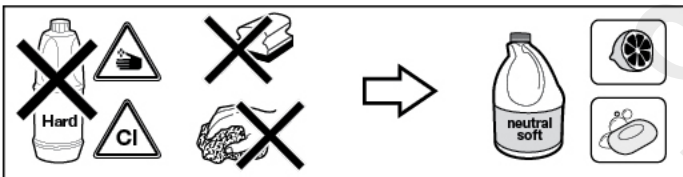

CONSEJOS DE LIMPIEZA ESPECIFICOS

Marcas de dedos o grasa: Las manchas persistentes de marcas de dedos, grasa, pueden ser tratadas con alcohol o acetona. Lavado final a continuación con abundante agua y jabón neutro para asegurar su total aclarado.

Restos de cal del agua: Aplicar una disolución de una parte de vinagre con tres partes de agua a las manchas directamente sobre las manchas y dejar actuar unos minutos. Después frotar con un paño suave o esponja humedecida. Lavado final con agua y jabón neutro para su total aclarado.

PRÁCTICAS NO ADMITIDAS (PÉRDIDA DE GARANTÍA)

- No aplicar detergentes con productos abrasivos, o que contengan:

- 1.- Ácido clorhídrico (sulfumán)
- 2.- Hipoclorito sódico (Lejía)
- 3.- Ácido fórmico.

- No utilizar utensilios, estropajos metálicos o esponjas abrasivas.

- No rociar directamente el detergente sobre la columna, porque el líquido puede entrar en las aperturas o hendiduras y causar daños.

- Limpiadores anti-cal o desincrustantes no son aptos para limpiar acero inoxidable.

- Limpiadores de plata contienen cloruros en su composición que atacan el acero inoxidable.

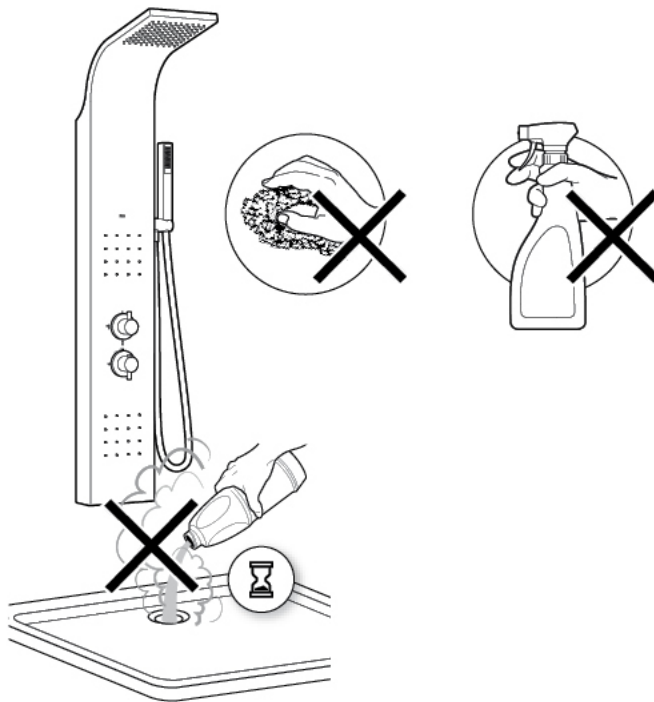

NOTA IMPORTANTE A EVITAR (PÉRDIDA DE GARANTÍA)

Una práctica habitual es utilizar lejía o desincrustantes en los cuartos de baño dejándolos actuar durante tiempo. Ésta práctica genera liberación de gases que contienen cloro y junto con la condensación de agua que tiene la columna, hace precipitar los cloruros en la superficie del inoxidable. Esto producirá oxidación en la superficie tanto interior como exterior.

LIMPIEZA DE FILTROS

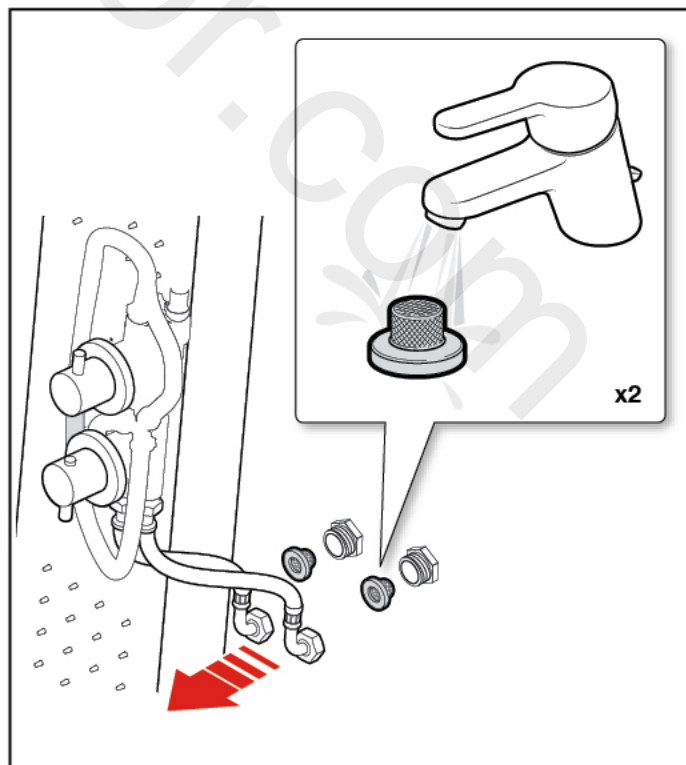



6. OPERATING INSTRUCTIONS

Using the **ESSENTIAL 2.0** hydrotherapy column's inverter switch you can select the following functions:

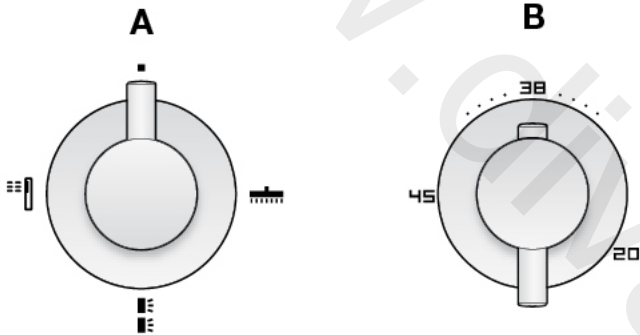
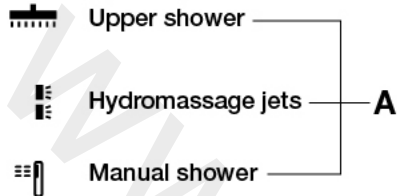

Simply turn the inverter switch (**A**) towards the desired position, moving it in either direction, even when the water is running. The combination of functions (**A**) can reduce the flow of water, compared to a single function.

The temperature selector allows you to choose the desired temperature, by turning the selector (**B**) to the left or right. As a precaution, for temperatures above 38° C, you must press the button and turn to the left.

6.1 CLEANING THE JETS

If the water streams from the jets are not correctly projected, there might be limescale accumulation in the water outlets.

It can easily be cleaned by scrubbing the silicone water outlets with a finger, with the water flowing.

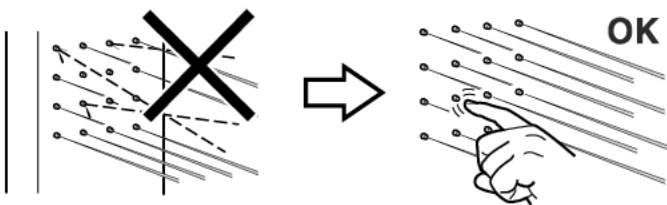

6.3 WARNINGS

Despite the preventive and relaxing therapeutic effects of hydro-massage, in case of acute illnesses, heart conditions, serious high blood pressure, etc., as well as for certain people (children, the elderly, pregnant women), special care must be taken regarding the duration, temperature and frequency of the massage. In these situations, it is advisable to previously consult a doctor.

Do not hang heavy objects on the column, as it has not been designed to support additional weight.



CLEANING STAINLESS STEEL

Stainless steel is highly resistant to rust, but there are some very strict cleaning and maintenance rules to be followed to prevent damage to its appearance.

GENERAL CLEANING TIPS

1. Apply neutral detergents formulated for these purposes (non-ionic surfactants and citric acid).
2. Apply the detergent with a soft cloth. Be careful with abrasive cloths. They may scratch the surface.
3. Rinse with water until all the detergent has gone.
4. Dry the column with a soft cloth.
5. Residue from hygiene products, liquid soap, shampoos, bath gel, etc, can also damage columns. Rinse the column with plenty of water after use.
6. Limescale stains can be prevented by drying the column with a soft cloth after use.

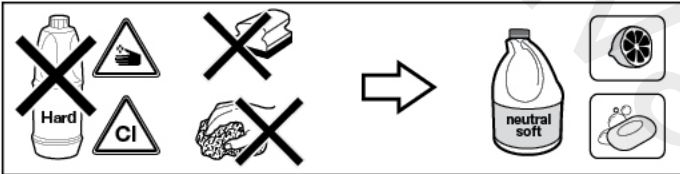

SPECIFIC CLEANING TIPS

Finger or grease marks: Persistent stains such as finger marks, grease, etc can be removed with alcohol or acetone. Then give it a final wash with plenty of water and neutral soap to ensure it is thoroughly rinsed.

Limescale from mains water: Apply a solution of one part vinegar and three parts water directly to the stains and leave to work for a few minutes. Then rub with a soft cloth or damp sponge. Then give it a final wash with plenty of water and neutral soap to ensure it is thoroughly rinsed.

UNACCEPTABLE PRACTICES (LOSS OF GUARANTEE)

- Do not apply detergents with abrasive products or which contain:

- 1.- Hydrochloric acid
- 2.- Sodium hypochlorite (bleach)
- 3.- Formic acid.

- Do not use abrasive utensils, metal scouring pads or abrasive sponges.

- Do not spray the detergent on the column, because the liquid can get into the openings or cracks in them and cause damage.

- Do not use anti-limescale and descaling cleaning products. They are not suitable for cleaning stainless steel.

- Do not use silver cleaners, contain chlorides that attack stainless steel.

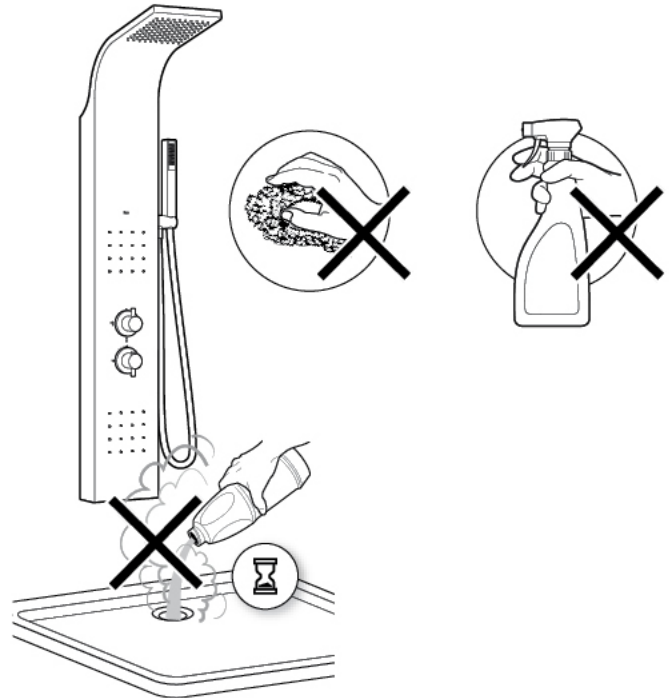

WARNING. IMPORTANT TO AVOID (LOSS OF GUARANTEE)

Bleach and descalers are often applied to bathroom equipment and left to work for a time. This leads to the release of gases that contain chloride, which together with the water in the column cause chlorides to run down the surface of the stainless steel. This rusts both internal and external surfaces.

CLEANING FILTERS

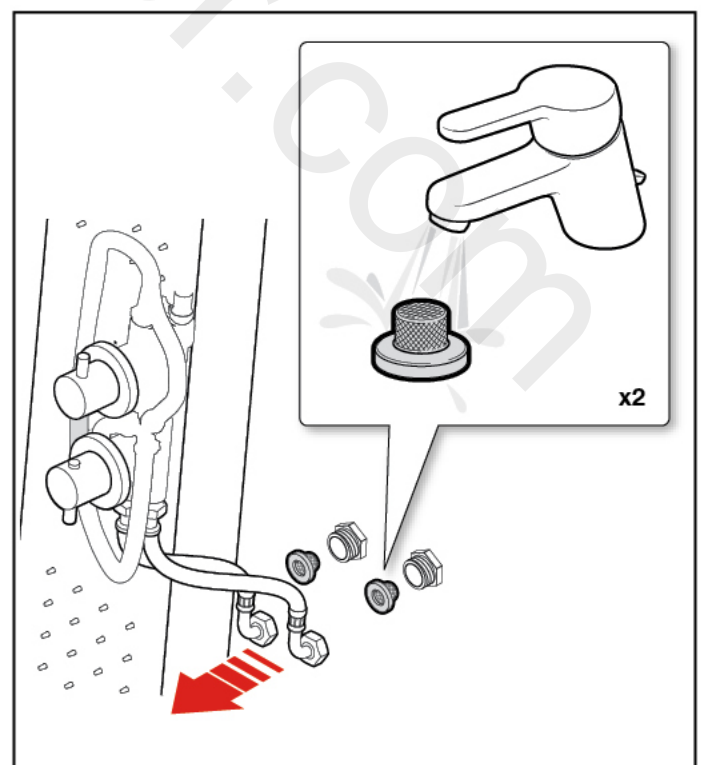

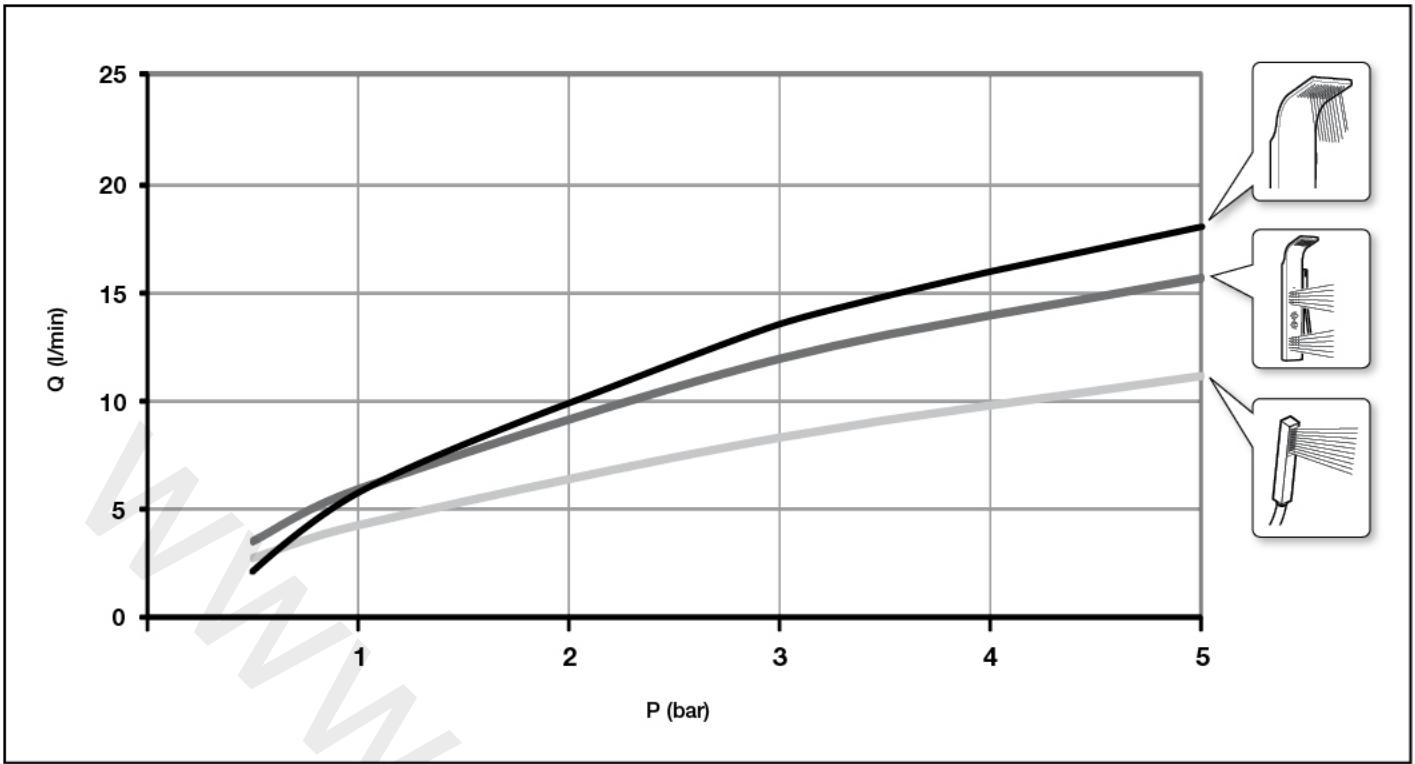

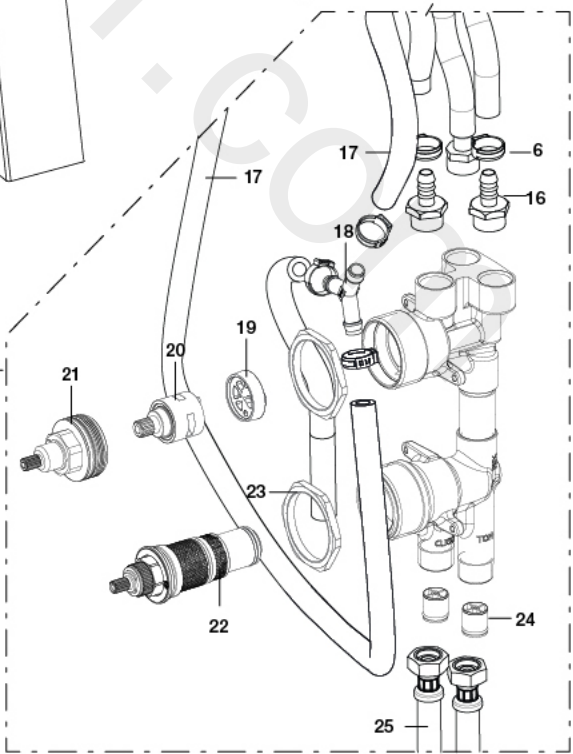
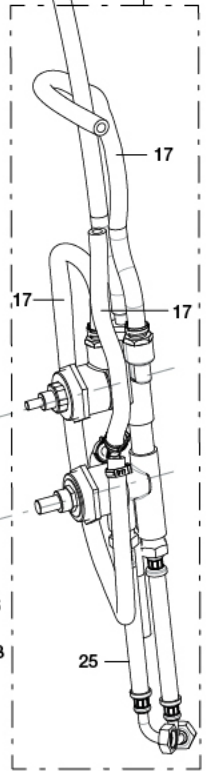
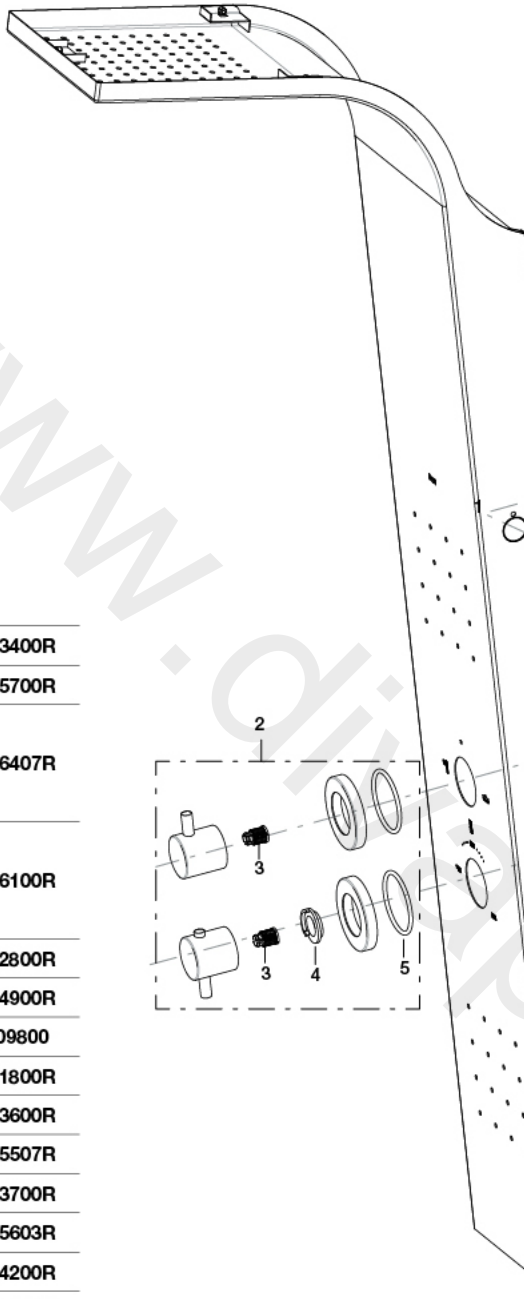

1		AD0003400R
2		AD0005700R
3	2	AD0006407R
4		
5	2	AC0006100R
6	3	
7		
18		
6	5	AD0002800R
8		AD0004900R
9		A525009800
10		AD0001800R
11	2	AD0003600R
12	4	AD0005507R
13	2	AD0003700R
14		AD0005603R
15		AD0004200R
16	2	AD0003100R
17	1,5m	AE0009200R
6	2	
19		AD0006107R
20		
21		AD0006203R
3		
22		AD0006307R
3		
23	2	AD0006003R
24	2	AD0005907R
25	2	AD0005809R

www.divapor.com



Roca Sanitario, S.A.
Avda. Diagonal, 513
08029 Barcelona
SPAIN
www.roca.com

**902
304
848** 
LÍNEA DE
ATENCIÓN AL
CONSUMIDOR
ESPAÑA

**902
400
423** 
SERVICIO
TÉCNICO
ESPAÑA

productsupport.rs@roca.net
soporteproducto.rs@roca.net

A2HG266000d