

AXOR[®]

hansgrohe

- EN** Installation / User Instructions / Warranty
- FR** Instructions de montage / Mode d'emploi / Garantie
- ES** Instrucciones de montaje / Manejo / Garantía

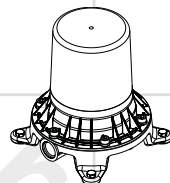

Axor Starck
10452181

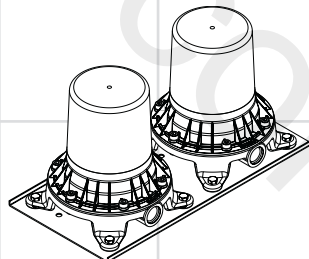

Axor Montreux
16549181

Technical Information

Recommended water pressure	15 - 75 PSI
Max. water pressure	145 PSI
Recommended hot water temp.	120° - 140° F*
Max. hot water temp	176° F*

*Please know and follow all applicable local plumbing codes when setting the temperature on the water heater.

Installation Considerations

- For best results, Hansgrohe recommends that this unit be installed by a licensed, professional plumber.
- Please read over these instructions thoroughly before beginning installation. Make sure that you have all tools and supplies needed to complete the installation.
- This faucet requires 1/2" NPT hot and cold supply lines (not included).
- The tub fillers are not anti-scald. If required by local code, install an approved remote pressure balance valve (not included) on the hot and cold supplies before they enter the rough.
- Keep this booklet and the receipt (or other proof of date and place of purchase) for this product in a safe place. The receipt is required should it be necessary to request warranty parts.

Données techniques

Pression d'eau recommandée	15 - 75 PSI
Pression d'eau maximum	145 PSI
Température recommandée d'eau chaude	120° - 140° F*
Température maximum d'eau chaude	176° F*

* Vous devez connaître et respecter tous les codes de plomberie locaux applicables pour le réglage de la température du chauffe-eau.

À prendre en considération pour l'installation

- Pour de meilleurs résultats, Hansgrohe recommande que ce produit soit installé par un plombier professionnel licencié.
- Veuillez lire attentivement ces instructions avant de procéder à l'installation. Assurez-vous de disposer de tous les outils et du matériel nécessaires pour l'installation.
- Ce robinet requiert des conduites d'alimentation d'eau chaude et d'eau froide de 1/2 po NPT (non comprises).
- Les robinets de baignoire ne possèdent pas de dispositif anti-brûlure. Si les codes locaux l'exigent, installez une valve d'équilibrage de pression à distance approuvée (non comprise) sur les conduites d'eau chaude et d'eau froide avant leur point d'insertion dans la pièce intérieure.
- Conservez ce livret et le reçu (ou une autre preuve sur laquelle figurent la date et l'endroit de l'achat) pour ce produit dans un endroit sûr. Le reçu est requis si vous commandez des pièces sous garantie.

Datos técnicos

Presión recomendada en servicio	15 - 75 PSI
Presión en servicio max.	145 PSI
Temperatura recomendada del agua caliente	120° - 140° F*
Temperatura del agua caliente max.	176° F*

*Debe conocer y cumplir todos los códigos locales aplicables para ajustar la temperatura del calentador de agua.

Consideraciones para la instalación

- Para obtener mejores resultados, la instalación debe estar a cargo de un plomero profesional matriculado.
- Antes de comenzar la instalación, lea estas instrucciones detenidamente. Asegúrese de tener las herramientas y los insumos necesarios para completar la instalación.
- Este grifo requiere tuberías de suministro de agua caliente y fría de ½" NPT (no incluidas).
- Los grifos de la bañera no son anti-escaldadura. Si así lo requiere su código local, instale una válvula remota de balance de presiones aprobada (no incluida) en los suministros de agua caliente y de agua fría antes de que ingresen a la pieza interior.
- Mantenga este folleto y el recibo (u otro comprobante del lugar y fecha de compra) de este producto en lugar seguro. El recibo se requiere en caso de ser necesario solicitar piezas bajo garantía.

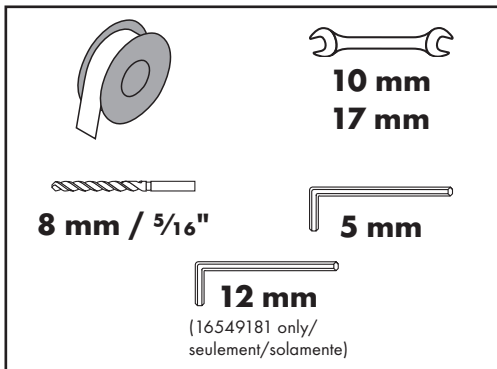
Tools Required / Outils Utiles / Herramientas Útiles

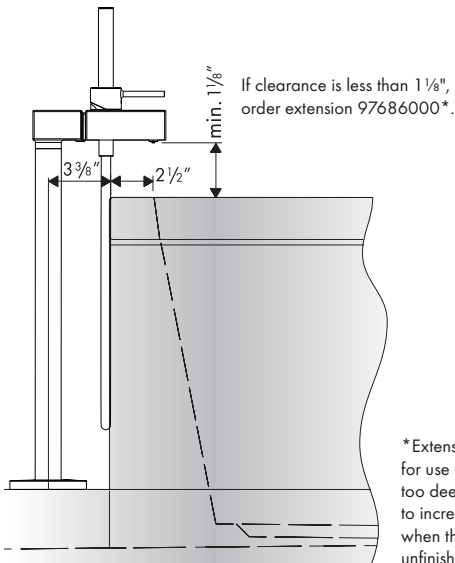
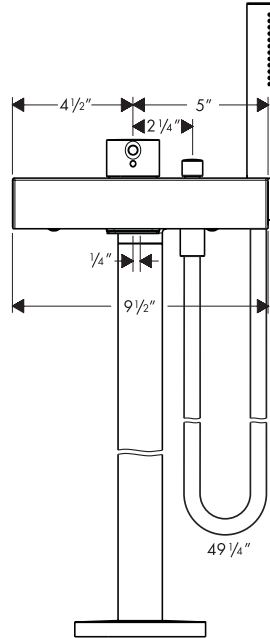
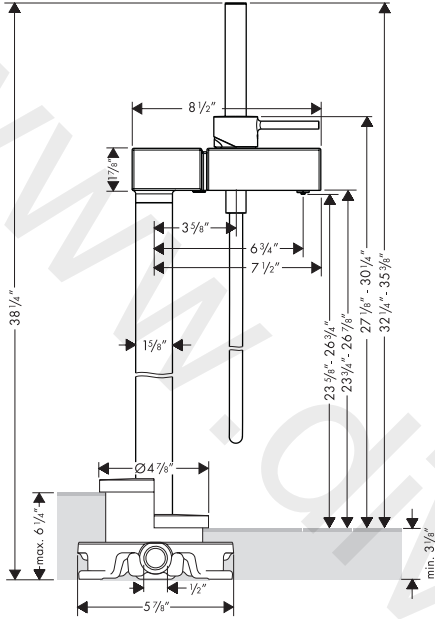

Tub shown: Duravit Philippe Starck
Starck X Freestanding tub with outside covering.

*Extension 97686000 is intended for use when the rough is installed too deeply in the floor. If it is used to increase the height of the tub filler when the rough is installed correctly, unfinished parts will be visible.

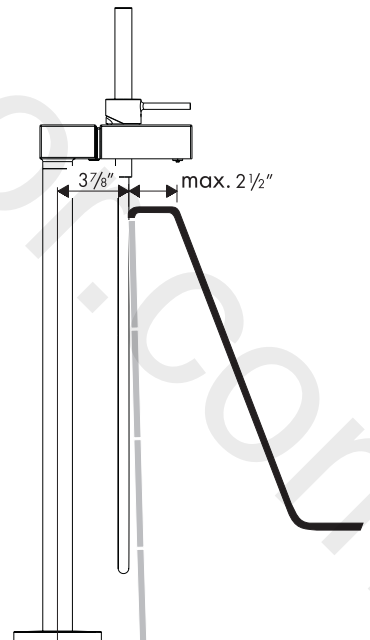

PuraVida 15473xx1

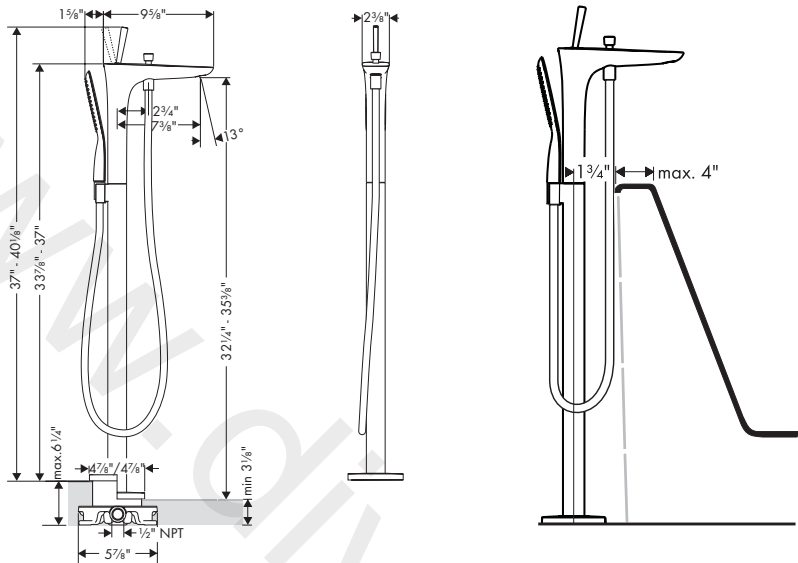

Installation – 10452181

Marquez les positions des trous de vissage sur le sous-plancher.

Percez les trous de vissage.

Installez les chevilles.

Installez les réducteurs de bruit, les rondelles et les vis.

Assurez-vous que la pièce intérieure est au niveau.

Installez des conduites d'alimentation d'eau chaude et d'eau froide filetéées NPT de 1/2 po.

Pour vous assurer que le robinet de baignoire fonctionne correctement, installez la conduite d'eau chaude à gauche et la conduite d'eau froide à droite.

Retirez le bouchon d'insertion pour rinçage du côté de l'eau froide sur la pièce intérieure. Installez une pièce d'accouplement et un tuyau.

Rincez la conduite d'eau froide.

Répétez la procédure de rinçage sur la conduite d'eau chaude.

Instalación – 10452181

Marque las posiciones de los orificios para los tornillos en el contrapiso.

Perfore los orificios para los tornillos.

Instale los pernos de anclaje.

Instale los reductores de ruido, las arandelas y los tornillos.

Confirme que la pieza interior quede nivelada.

Instale líneas de suministro de agua caliente y agua fría NPT de 1/2".

Para asegurar el funcionamiento adecuado del grifo de la bañera, instale el suministro de agua caliente en el lado izquierdo y el suministro de agua fría en el lado derecho.

Retire el tapón del inserto de lavado del lado del agua fría de la pieza interior. Instale una espita para manguera y una manguera.

Deje fluir el agua fría.

Repita el procedimiento de lavado con el suministro de agua caliente.

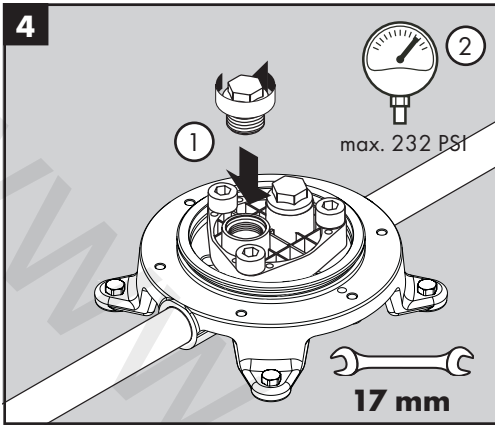

Replace and tighten the plugs.

Pressure test the unit.

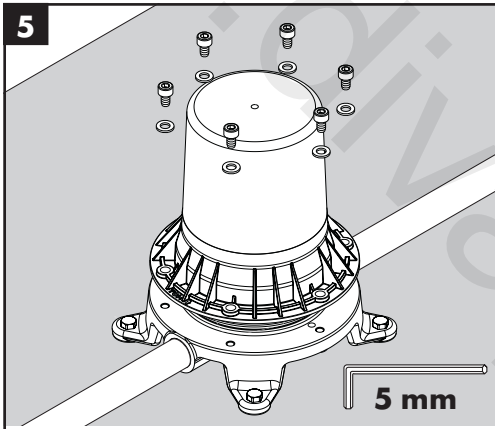

Install the plaster shield.

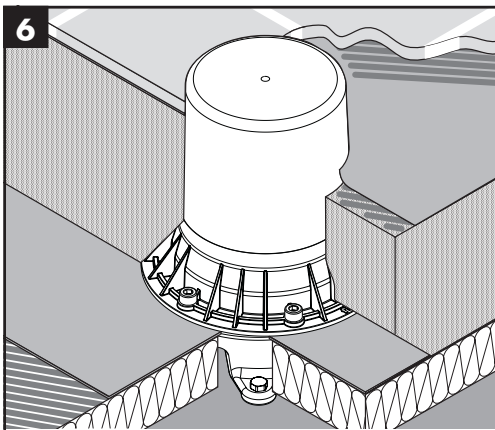

Install the flooring material.

To insure proper fit of the tub filler, the surface of the finished floor **must** fall somewhere between the "minimum" and "maximum" markings on the plaster shield.



Know and follow all applicable local codes regarding waterproofing.

Français

Remettez les bouchons en place et serrez-les.

Testez la pression du produit.

Español

Reemplace y ajuste los tapones.

Realice una prueba de presión de la unidad.

Installez le protecteur.

Instale el protector de yeso.

Installez les matériaux du plancher.

Pour que le robinet de baignoire s'ajuste de façon adéquate, la surface du plancher fini doit se situer entre les marques « minimum » et « maximum » figurant sur le protecteur.



Vous devez connaître et respecter les codes locaux en vigueur relatifs à l'étanchéité.

Instale el material para revestimiento del piso.

Para asegurar el ajuste adecuado del grifo de la bañera, la superficie del acabado del piso debe estar entre las marcas de "mínimo" y "máximo" en el protector de yeso.



Debe conocer y cumplir con todos los códigos locales aplicables respecto de la impermeabilidad.

16549181

Axor Montreux 16547xx1 / 16553xx1

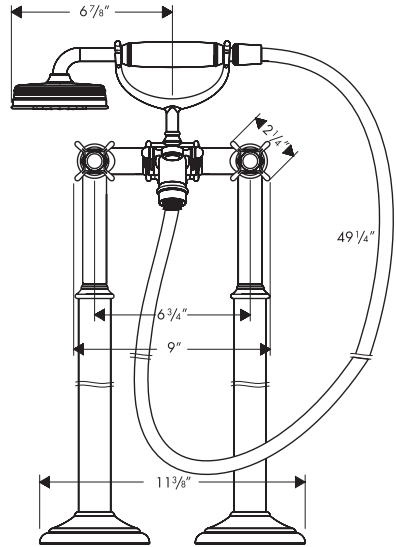
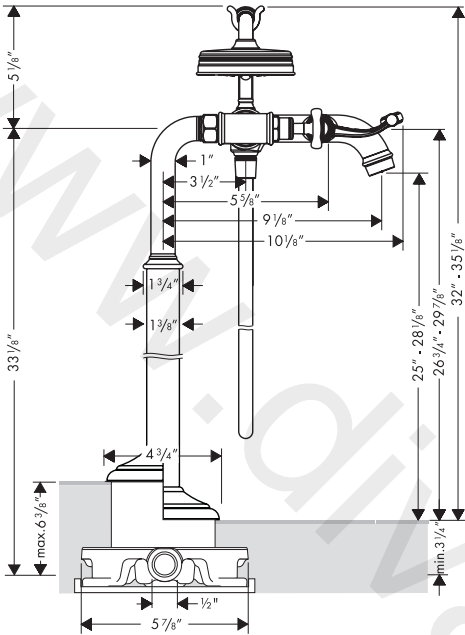

English

Installation - 16549181

Wrap the threads on the two brass plugs with Teflon tape.

Install one plug on each rough.

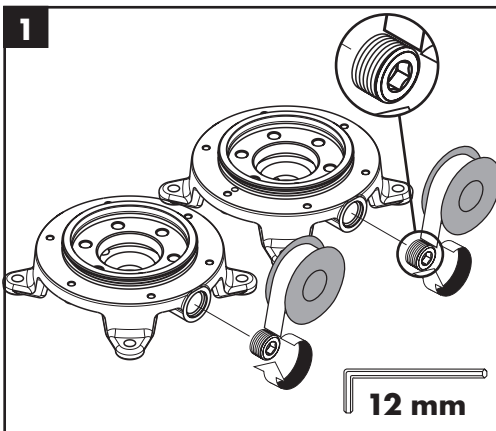

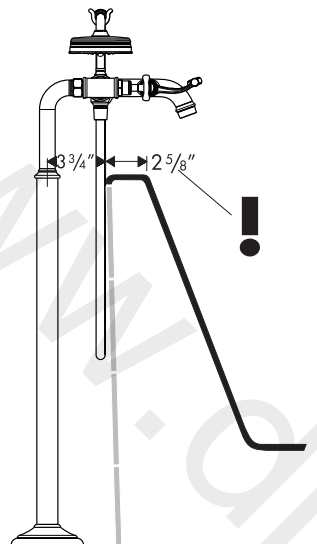

Français

Installation – 16549181

Enveloppez les filets des deux bouchons de laiton avec du ruban Téflon.

Installez un bouchon sur chaque pièce intérieure.

Español

Instalación – 16549181

Envuelva las roscas de los dos tapones de latón con cinta de Teflon.

Instale un tapón en cada pieza interior.

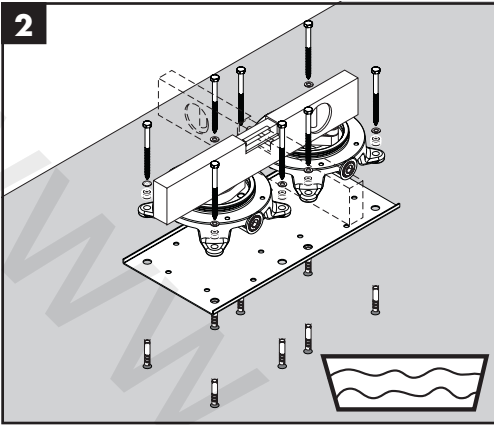

- Mark the positions of the screw holes in the subfloor.
- Drill the screw holes.
- Install the anchors.
- Install the noise reducers, washers, and screws.
- Confirm that the rough is level.

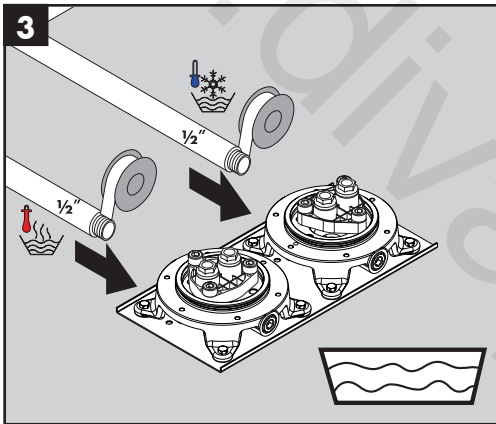

- Install 1/2" NPT hot and cold supply lines.
- To insure correct operation of the tub filler, install the hot supply on the left, and the cold supply on the right.

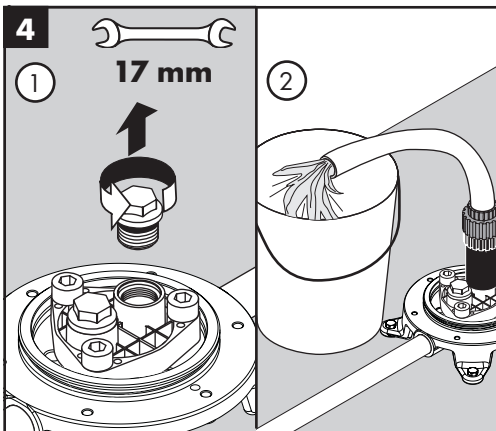

- Remove the flush insert plug from the cold water side of the rough. Install a hose bibb and a hose.
- Flush the cold supply.
- Repeat the flushing procedure on the hot supply.

Français

Marquez les positions des trous de vissage sur le sous-plancher.

Percez les trous de vissage.

Installez les chevilles.

Installez les réducteurs de bruit, les rondelles et les vis.

Assurez-vous que la pièce intérieure est au niveau.

Installez des conduites d'alimentation d'eau chaude et d'eau froide filetéées NPT de 1/2 po.

Pour vous assurer que le robinet de baignoire fonctionne correctement, installez la conduite d'eau chaude à gauche et la conduite d'eau froide à droite.

Retirez le bouchon d'insertion pour rinçage du côté de l'eau froide sur la pièce intérieure. Installez une pièce d'accouplement et un tuyau.

Rincez la conduite d'eau froide.

Répétez la procédure de rinçage sur la conduite d'eau chaude.

Español

Marque las posiciones de los orificios para los tornillos en el contrapiso.

Perfore los orificios para los tornillos.

Instale los pernos de anclaje.

Instale los reductores de ruido, las arandelas y los tornillos.

Confirme que la pieza interior quede nivelada.

Instale líneas de suministro de agua caliente y agua fría NPT de 1/2".

Para asegurar el funcionamiento adecuado del grifo de la bañera, instale el suministro de agua caliente en el lado izquierdo y el suministro de agua fría en el lado derecho.

Retire el tapón del inserto de lavado del lado del agua fría de la pieza interior. Instale una espita para manguera y una manguera.

Deje fluir el agua fría.

Repita el procedimiento de lavado con el suministro de agua caliente.

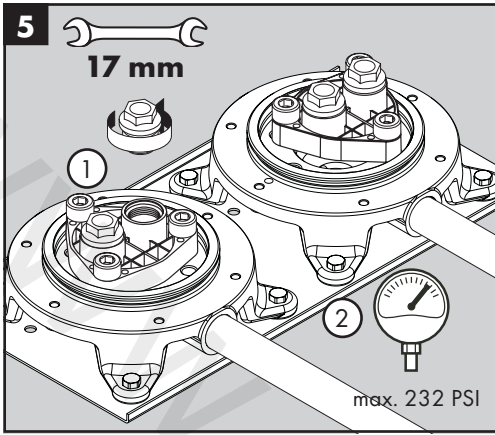

Replace and tighten the plugs.

Pressure test the unit.

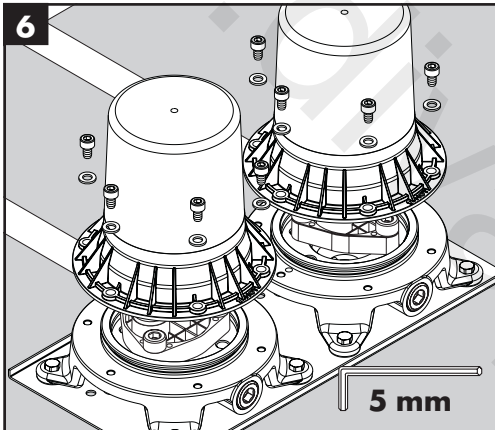

Install the plaster shields.

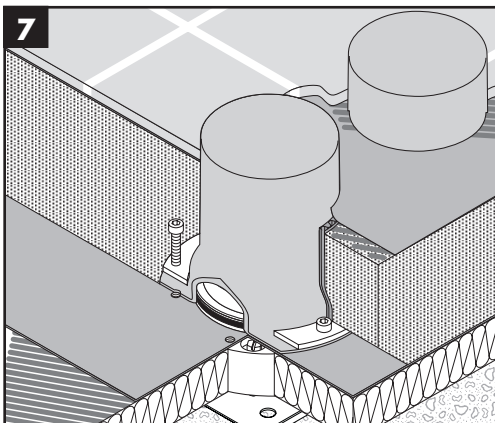

Install the flooring material.

To insure proper fit of the tub filler, the surface of the finished floor **must** fall somewhere between the "minimum" and "maximum" markings on the plaster shield.



Know and follow all applicable local codes regarding waterproofing.

Français

Remettez les bouchons en place et serrez-les.

Testez la pression du produit.

Español

Reemplace y ajuste los tapones.

Realice una prueba de presión de la unidad.

Installez les protecteurs.

Instale los protectores de yeso.

Installez les matériaux du plancher.

Pour que le robinet de baignoire s'ajuste de façon adéquate, la surface du plancher fini doit se situer entre les marques « minimum » et « maximum » figurant sur le protecteur.



Vous devez connaître et respecter les codes locaux en vigueur relatifs à l'étanchéité.

Instale el material para revestimiento del piso.

Para asegurar el ajuste adecuado del grifo de la bañera, la superficie del acabado del piso debe estar entre las marcas de "mínimo" y "máximo" en el protector de yeso.



Debe conocer y cumplir con todos los códigos locales aplicables respecto de la impermeabilidad.

Replacement Parts / Pièces détachées / Repuestos

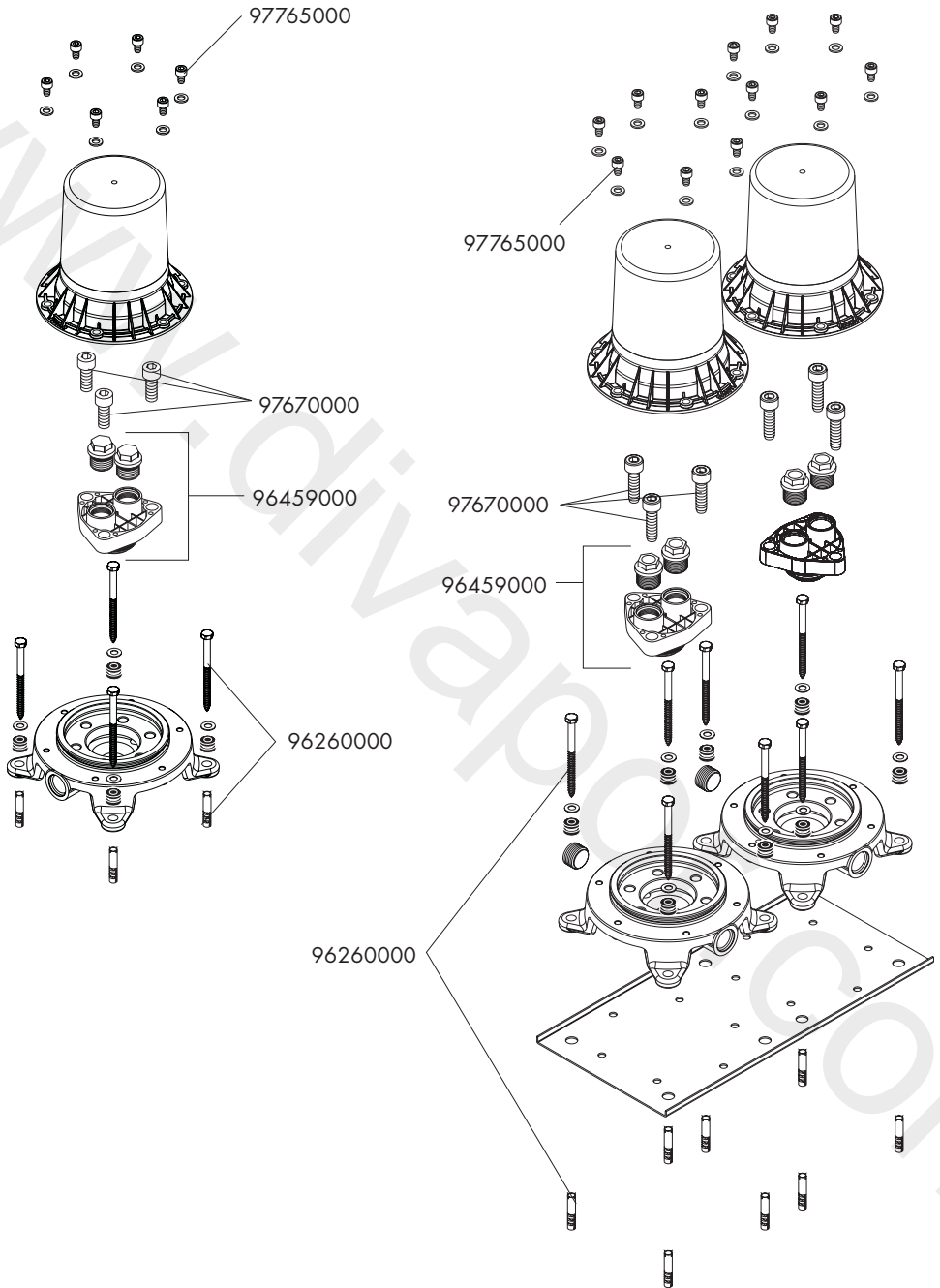

Limited Consumer Warranty

This product has been manufactured and tested to the highest quality standards by Hansgrohe, Inc. ("Hansgrohe"). This warranty is limited to Hansgrohe products that are purchased by a consumer in the United States or Canada after March 1, 1996, and installed in either in the United States or in Canada.

WHO IS COVERED BY THE WARRANTY

This warranty extends to the original purchaser only. This warranty is non-transferable.

WHAT IS COVERED BY THE WARRANTY

The warranty covers only your Hansgrohe manufactured product. Hansgrohe warrants this product against defects in material or workmanship as follows:

Hansgrohe will replace at no charge for parts only or, at its option, replace any product or part of the product that proves defective because of improper workmanship and/or material, under normal installation, use, service and maintenance. If Hansgrohe is unable to provide a replacement and repair is not practical or cannot be made in timely fashion, Hansgrohe may elect to refund the purchase price in exchange for the return of the product.

LENGTH OF WARRANTY

Replacement or repaired parts of products will be covered for the term of this warranty, as stated in the following two sentences. If you are a consumer who purchased the product for use primarily for personal, family or household purposes, this warranty extends for as long as you own the product and the home in which the product is originally installed. If you purchased the product for use primarily for any other purpose, including, without limitation, a commercial purpose, this warranty extends only (i) for 1 year, with respect to Hansgrohe & Commercial products, and (ii) for 5 years, with respect to Axor products.

THIS WARRANTY DOES NOT COVER, AND HANSGROHE WILL NOT PAY FOR:

- A. Conditions, malfunctions or damage not resulting from defects in material or workmanship.
- B. Conditions, malfunctions or damage resulting from (1) normal wear and tear, improper installation, improper maintenance, misuse, abuse, negligence, accident or alteration; (2) the use of abrasive or caustic cleaning agents or "no-rinse" cleaning products, or the use of the product in any manner contrary to the product instructions; or (3) conditions in the home such as excessive water pressure or corrosion.
- C. Labor and other expenses for disconnection, deinstallation, or return of the product for warranty service (including but not limited to proper packaging and shipping costs), or for installation or reinstallation of the product.
- D. Accessories, connected materials and products, or related products not manufactured by Hansgrohe.
- E. Any Hansgrohe or Axor product sold for display purposes.
- F. Rubbed Bronze finish is subject to a 3-year limited warranty. Chrome and all PVD finishes are covered by the limited lifetime warranty.
- G. Hansgrohe Water Filtration System is subject to a 1-year limited warranty. Warranty does not include replacement filters.

TO OBTAIN WARRANTY PARTS OR INFORMATION

Contact your Hansgrohe retailer, or contact Technical Service at:

Hansgrohe, Inc.
1492 Bluegrass Lakes Parkway
Alpharetta, GA 30004
Toll-free 800-334-0455

In requesting warranty service, you will need to provide:

1. The sales receipt or other evidence of the date and place of purchase.
2. A description of the problem.
3. Delivery of the product or the defective part, postage prepaid and carefully packed and insured, to:

Hansgrohe, Inc.
1492 Bluegrass Lakes Parkway
Alpharetta, GA 30004
Toll-free 800-334-0455

When warranty service is completed, any repaired or replacement product or part will be returned to you postage prepaid.

EXCLUSIONS AND LIMITATIONS

REPAIR OR REPLACEMENT (OR, IN LIMITED CIRCUMSTANCES, REFUND OF THE PURCHASE PRICE) AS PROVIDED UNDER THIS WARRANTY IS THE EXCLUSIVE REMEDY OF THE PURCHASER. HANSGROHE NEITHER ASSUMES NOR AUTHORIZES ANY PERSON TO CREATE FOR IT ANY OTHER OBLIGATION OR LIABILITY IN CONNECTION WITH THIS PRODUCT. HANSGROHE SHALL NOT BE LIABLE TO PURCHASER OR ANY OTHER PERSON FOR ANY INCIDENTAL, SPECIAL OR CONSEQUENTIAL DAMAGES, ARISING OUT OF BREACH OF THIS WARRANTY OR ANY IMPLIED WARRANTY (INCLUDING BUT NOT LIMITED TO ANY IMPLIED WARRANTY OF MERCHANTABILITY).

Some States do not allow the exclusion or limitation of incidental or consequential damages, so the above limitation or exclusion may not apply to you. This warranty gives you specific legal rights, and you may also have other rights that vary from state to state.

TO THE EXTENT PERMITTED BY LAW, ANY IMPLIED WARRANTIES OF MERCHANTABILITY AND FITNESS FOR A PARTICULAR PURPOSE, ARE LIMITED TO THE DURATION OF THE EXPRESS WARRANTY.

Some states do not allow limitations on how long an implied warranty may last, so the above limitations may not apply to you. You may be required by law to give us a reasonable opportunity to correct or cure any failure to comply before you can bring any action in court against us under the Magnuson-Moss Warranty Act.

PRODUCT INSTRUCTIONS AND QUESTIONS

Upon purchase or prior to installation, please carefully inspect your Hansgrohe product for any damage or visible defect. Prior to installing, always carefully study the enclosed instructions on the proper installation and the care and maintenance of this product. If you have questions at any time about the use, installation or performance of your Hansgrohe product, or this warranty, please write us or call us toll-free at 800-334-0455.

hansgrohe

Hansgrohe, Inc. • 1490 Bluegrass Lakes Parkway • Alpharetta, GA 30004
Tel. 800-334-0455 • Fax 770-360-9887

www.hansgrohe-usa.com