

hansgrohe

- EN** Installation / User Instructions / Warranty
FR Instructions de montage / Mode d'emploi / Garantie
ES Instrucciones de montaje / Manejo / Garantía

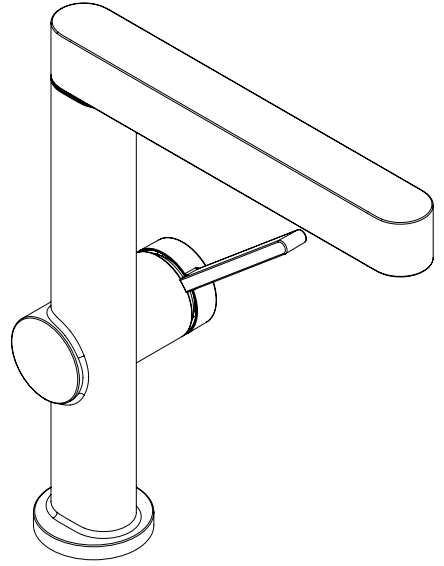

Finoris™ 230 2jet
76063XX1

Technical Information

Recommended water pressure	15 - 75 PSI
Max. water pressure	145 PSI
Recommended hot water temp.	120° - 140° F*
Max. hot water temp	176° F*
Flow rate	1.2 GPM
Hole size in mounting surface	1 ³ / ₈ "
Max. depth of mounting surface	1 ⁵ / ₈ "

* Please know and follow all applicable local plumbing codes when setting the temperature on the water heater.

Installation Considerations

- For best results, Hansgrohe recommends that this unit be installed by a licensed, professional plumber.
- Please read over these instructions thoroughly before beginning installation. Make sure that you have all tools and supplies needed to complete the installation.
- Inspect the faucet for shipping damage before installation. Hansgrohe will not honor claims for shipping damage after the faucet is installed.
- This faucet does not include a drain or a pull rod.
- The check valves should be inspected yearly, and replaced if dirty or worn (see page 14).
- The included adapters must be used. They adapt the G ³/₈ supply hoses to ³/₈" stops.
- Keep this booklet and the receipt (or other proof of date and place of purchase) for this product in a safe place. The receipt is required should it be necessary to request warranty parts.

Données techniques

Pression d'eau recommandée	15 - 75 PSI
Pression d'eau maximum	145 PSI
Température recommandée d'eau chaude	120° - 140° F*
Température maximum d'eau chaude	176° F*
Capacité nominale	1.2 GPM
Dimension du trou dans la surface de montage	1 3/8 po
Profondeur maximale de la surface de montage	1 5/8 po

* Vous devez connaître et respecter tous les codes de plomberie locaux applicables pour le réglage de la température du chauffe-eau.

À prendre en considération pour l'installation

- Pour de meilleurs résultats, Hansgrohe recommande que ce produit soit installé par un plombier professionnel licencié.
- Veuillez lire attentivement ces instructions avant de procéder à l'installation. Assurez-vous de disposer de tous les outils et du matériel nécessaires pour l'installation.
- Inspectez le robinet afin de vérifier s'il a été endommagé pendant l'expédition avant de procéder à son installation. Hansgrohe n'acceptera aucune réclamation de dommages survenant pendant l'expédition une fois que le robinet a été installé.
- Cette robinetterie n'incluent pas un obturateur à clapet ou une tirette.
- Les clapets anti-retour doivent être inspectés chaque année et remplacés s'ils sont sales ou usés (voir page 14).
- Les adaptateurs fournis doivent être utilisés. Ils adaptent les tuyaux d'alimentation G 3/8 aux butées 3/8 po.
- Conservez ce livret et le reçu (ou une autre preuve sur laquelle figurent la date et l'endroit de l'achat) pour ce produit dans un endroit sûr. Le reçu est requis si vous commandez des pièces sous garantie.

Datos técnicos

Presión recomendada en servicio	15 - 75 PSI
Presión en servicio max.	145 PSI
Temperatura recomendada del agua caliente	120° - 140° F*
Temperatura del agua caliente max.	176° F*
Caudal máximo	1.2 GPM
Tamaño del orificio en la superficie de montaje	1 $\frac{3}{8}$ po
Profundidad máxima de la superficie de montaje	1 $\frac{5}{8}$ po

* Debe conocer y cumplir todos los códigos locales aplicables para ajustar la temperatura del calentador de agua.

Consideraciones para la instalación

- Para obtener mejores resultados, la instalación debe estar a cargo de un plomero profesional matriculado.
- Antes de comenzar la instalación, lea estas instrucciones detenidamente. Asegúrese de tener las herramientas y los insumos necesarios para completar la instalación.
- Inspeccione el grifo antes de instalarlo para detectar cualquier daño causado por el transporte. Hansgrohe no será responsable por reclamos por daños causados por el transporte una vez que el grifo esté instalado.
- Esta grifería no incluyen un tapón elevable ni un tirador.
- Las válvulas antirretorno deben inspeccionarse anualmente y reemplazarse si están sucias o gastadas (consulte la página 14).
- Debe usar los adaptadores incluidos. Estos sirven para adaptar las mangueras de suministro G $\frac{3}{8}$ a las llaves de paso de $\frac{3}{8}$ ".
- Mantenga este folleto y el recibo (u otro comprobante del lugar y fecha de compra) de este producto en lugar seguro. El recibo se requiere en caso de ser necesario solicitar piezas bajo garantía.

Finoris 230 2jet
76063XX1

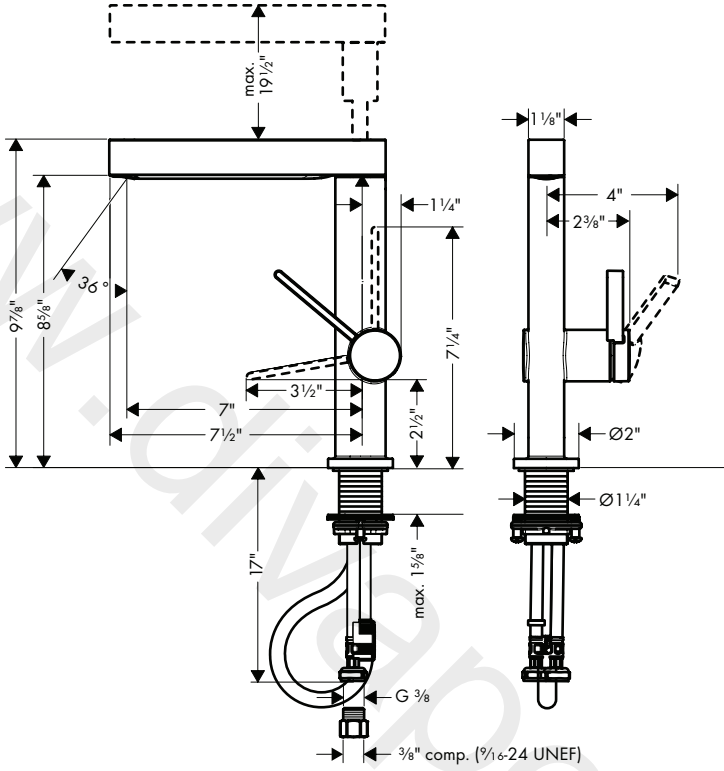

**Tools Required / Outils Requis /
Herramientas Útiles**

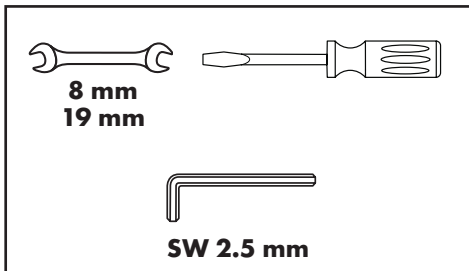

Installation / Installation / Instalación

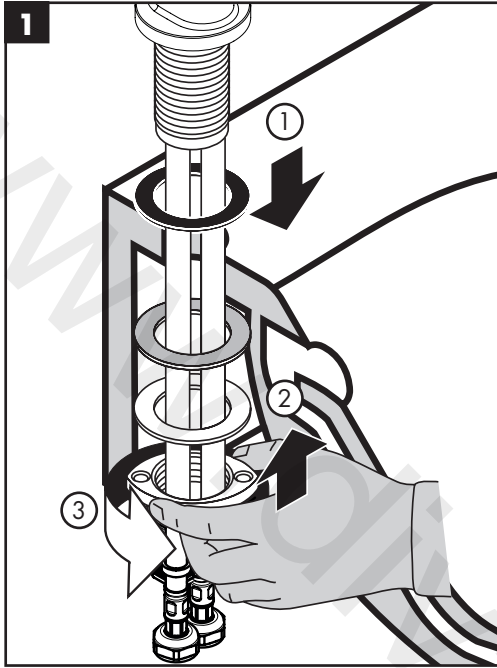

Place the fiber washer, then the friction washer and then the mounting nut onto the faucet.

Tighten to countertop by hand.

Placez la rondelle en fibre, puis la rondelle de friction et ensuite l'écrou de montage sur le robinet.

Serrez au comptoir à la main.

Coloque la arandela de fibra, luego la arandela de fricción y luego la tuerca de montaje en el grifo.

Ajuste la mesada con la mano.

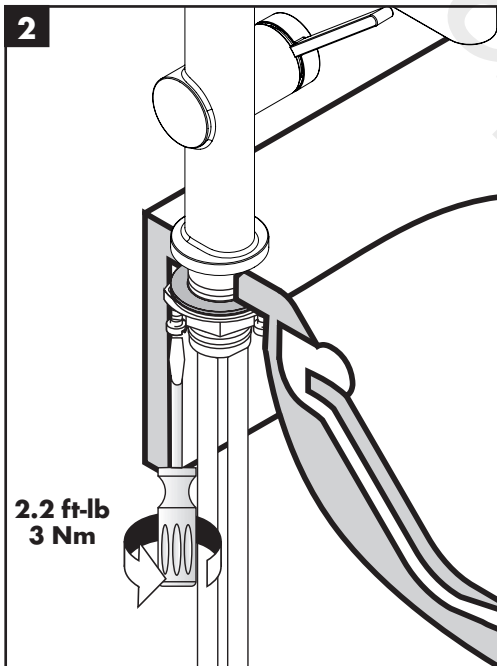

Tighten the tensioning screws.

Serrez les vis de pression.

Apretete los tornillos tensores.

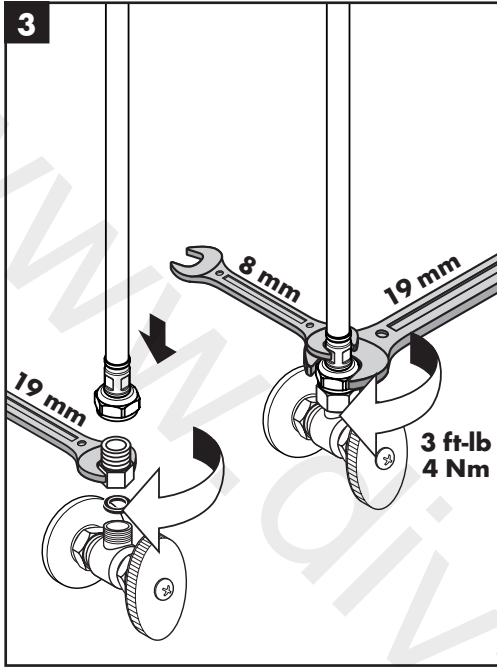

Install the adapters to the stops.

Connect the supply lines to the adapters.

⚠ **Use two wrenches. Do not allow the hoses to twist.**

Raccordez les conduites d'alimentation aux butées d'arrêt.

⚠ **Utilisez deux clés. Assurez-vous que les tuyaux ne s'entortillent pas.**

Conecte las líneas de suministro a las llaves de paso.

⚠ **Use dos llaves. No permita que las mangueras se retuerzan.**

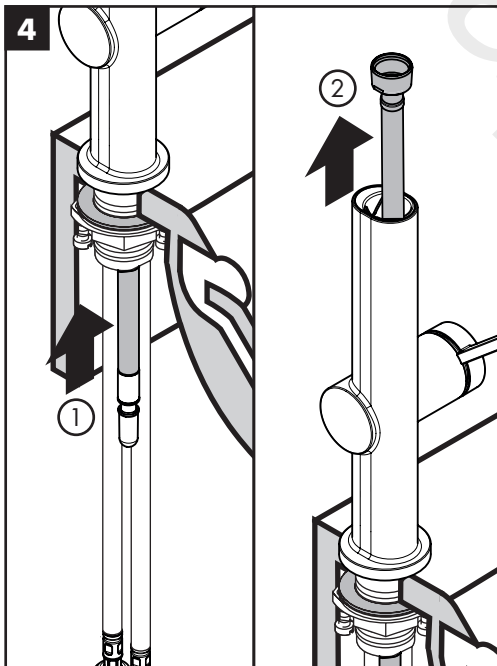

Push up on the pullout sprayer hose from the bottom of the faucet and remove some hose slack from the top.

Poussez sur le tuyau de l'arroseur rétractable du bas du robinet et retirez un peu de mou du haut du tuyau.

Empuje hacia arriba de la manguera rociadora tipo tirador desde la parte inferior del grifo y elimine algo de flojedad de la parte superior.

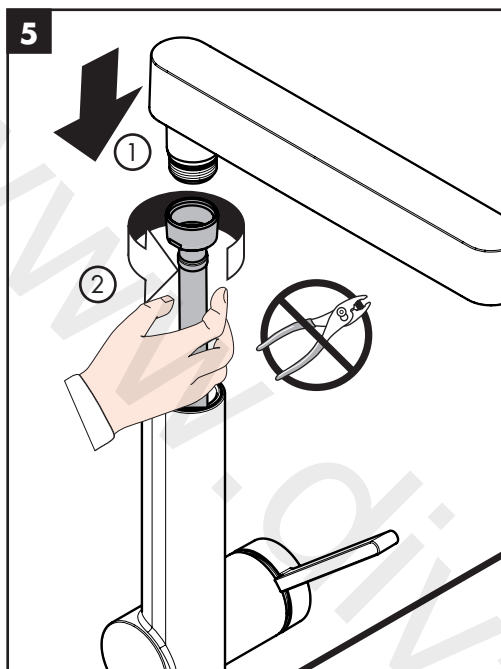

Press the spout connection into the pullout hose and tighten the hose nut by hand

⚠ **Do not use pliers.**

Enfoncez le raccord du bec dans le tuyau rétractable et serrez l'écrou du tuyau à la main

⚠ **N'utilisez pas de pinces.**

Presione la conexión del surtidor en la manguera tipo tirador y ajuste la tuerca de la manguera con la mano.

⚠ **No utilice pinzas.**

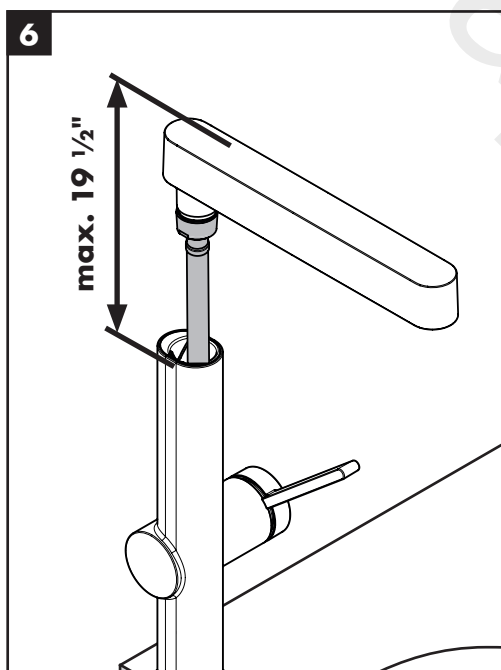

Pull up on the spout a maximum of 19 1/2" and carefully set it down on a towel or other soft surface.

Tirez sur le bec d'un maximum de 19 1/2 po et posez-le soigneusement sur une serviette ou une autre surface douce.

Tire hacia arriba del surtidor un máximo de 19 1/2" y cuidadosamente colóquelo sobre una toalla u otra superficie suave.

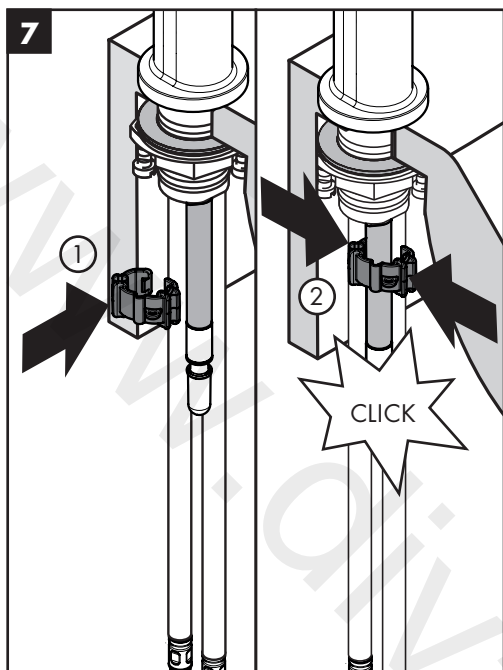

Snap the retainer clip onto the remaining pullout hose on the underside of the faucet to limit the maximum pullout length.

Enclenchez le clip de retenue sur le tuyau rétractable restant sur la face inférieure du robinet pour limiter la longueur rétractable maximale.

Acople la presilla de retención en la manguera tipo tirador restante en la parte inferior del grifo para limitar la longitud máxima para tirar.

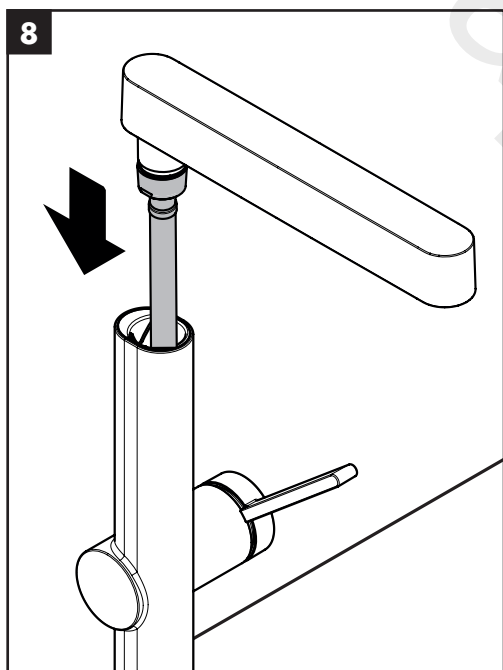

Return the spout to its resting position.

Remettez le bec en position de repos.

Vuelva el surtidor a su posición de descanso.

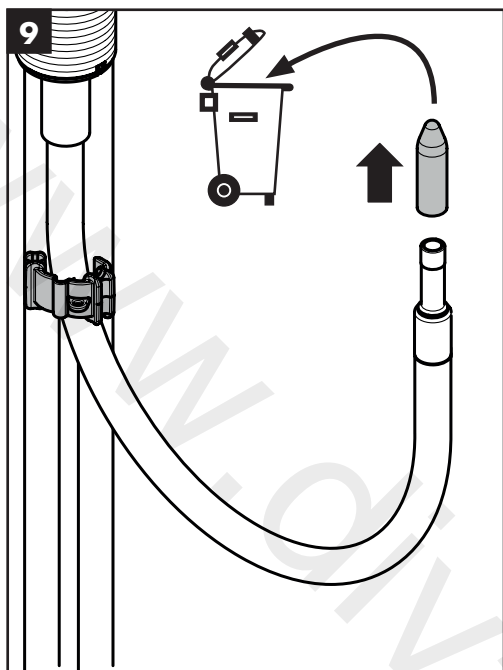

Remove the protective cap from the quickconnect barb at the end of the pullout hose and discard.

Retirez le capuchon de protection de la cannelure de connexion rapide à l'extrémité du tuyau rétractable et jetez-le.

Quite la tapa protectora de la lengüeta de conexión rápida en el extremo de la manguera tipo tirador y deséchela.

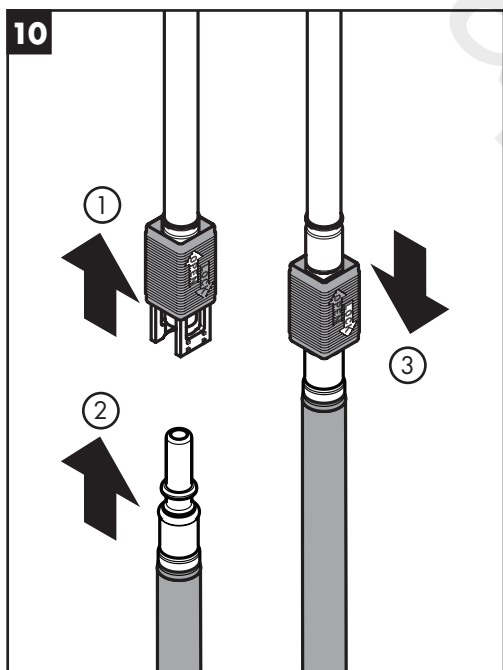

Push the quickconnect barb into the coupling hose and slide the retainer sleeve down until it clicks.

Poussez la cannelure de connexion rapide dans le tuyau de raccordement et faites glisser le manchon de retenue vers le bas jusqu'à ce qu'il s'enclenche.

Empuje la lengüeta de conexión rápida en la manguera de acople y deslice el manguito de retención hacia abajo hasta que haga clic.

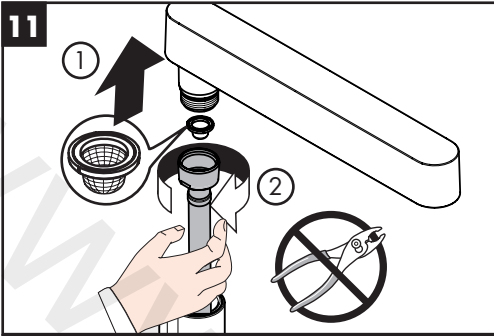

Remove the spout from the pullout hose

Clean the filter under running water.

Retirez le bec du tuyau rétractable

Nettoyez le filtre sous l'eau courante.

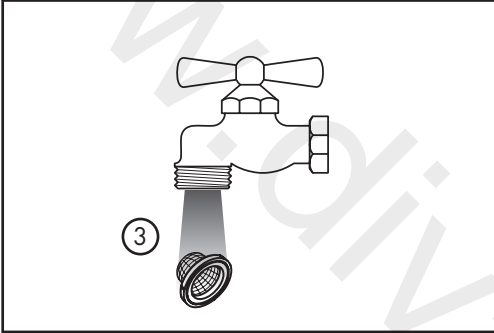

Retire el surtidor de la manguera tipo tirador.

Limpie el filtro haciendo pasar agua.

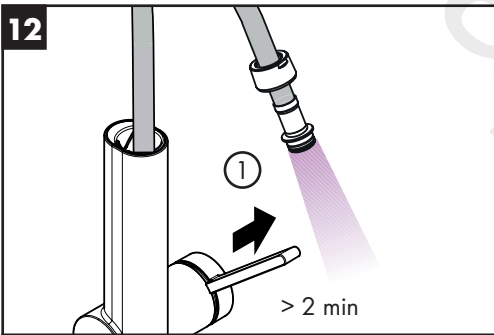

Flush the faucet with water for at least two minutes.

Reinstall the filter in the pullout hose and reconnect the pullout hose to the spout, tightening the nut by hand.

Rincez le robinet avec de l'eau pendant au moins deux minutes.

Réinstallez le filtre dans le tuyau rétractable et reconnectez le tuyau rétractable au bec en serrant l'écrou à la main.

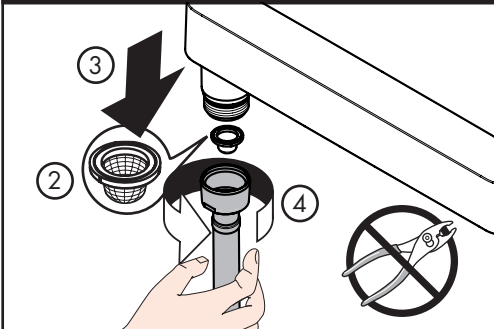

Purgue el grifo con agua durante al menos dos minutos.

Vuelva a colocar el filtro en la manguera tipo tirador y vuelva a conectar la manguera al surtidor, ajustando la tuerca con la mano.

Set hot water limiter / Positionner le limiteur de température / Ajustar tope

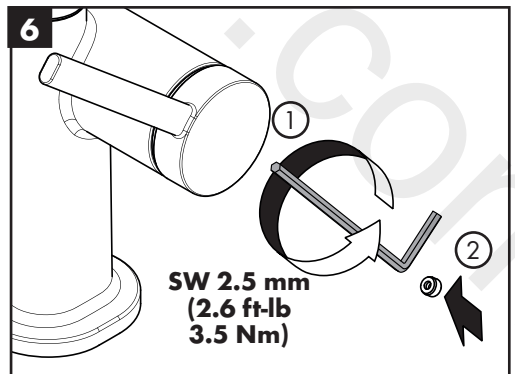
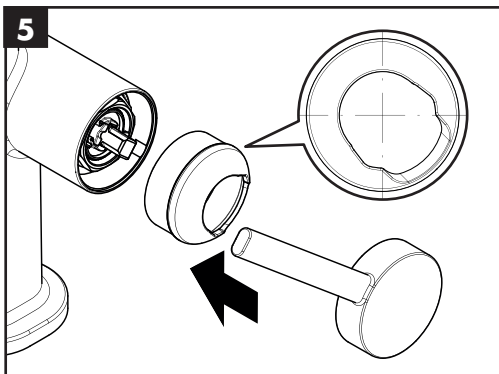
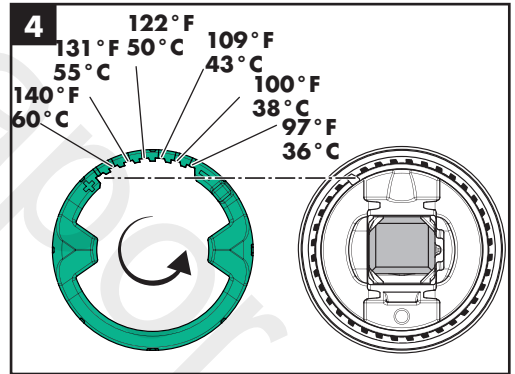
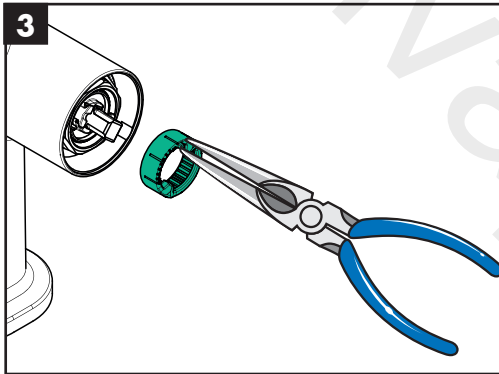
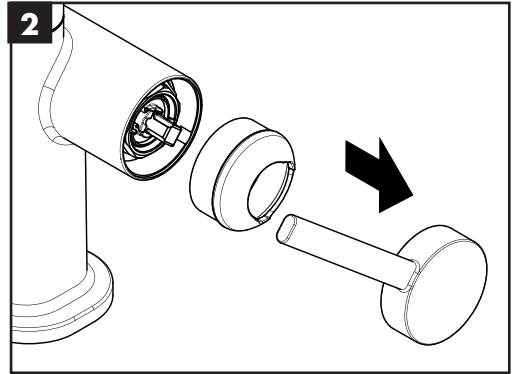
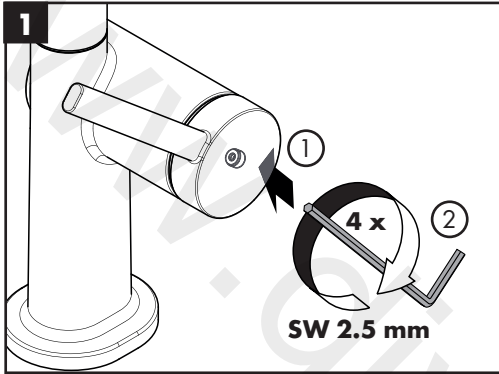

Replacement Parts / Pièces détachées / Repuestos

Finoris 230 2jet
76063XX1

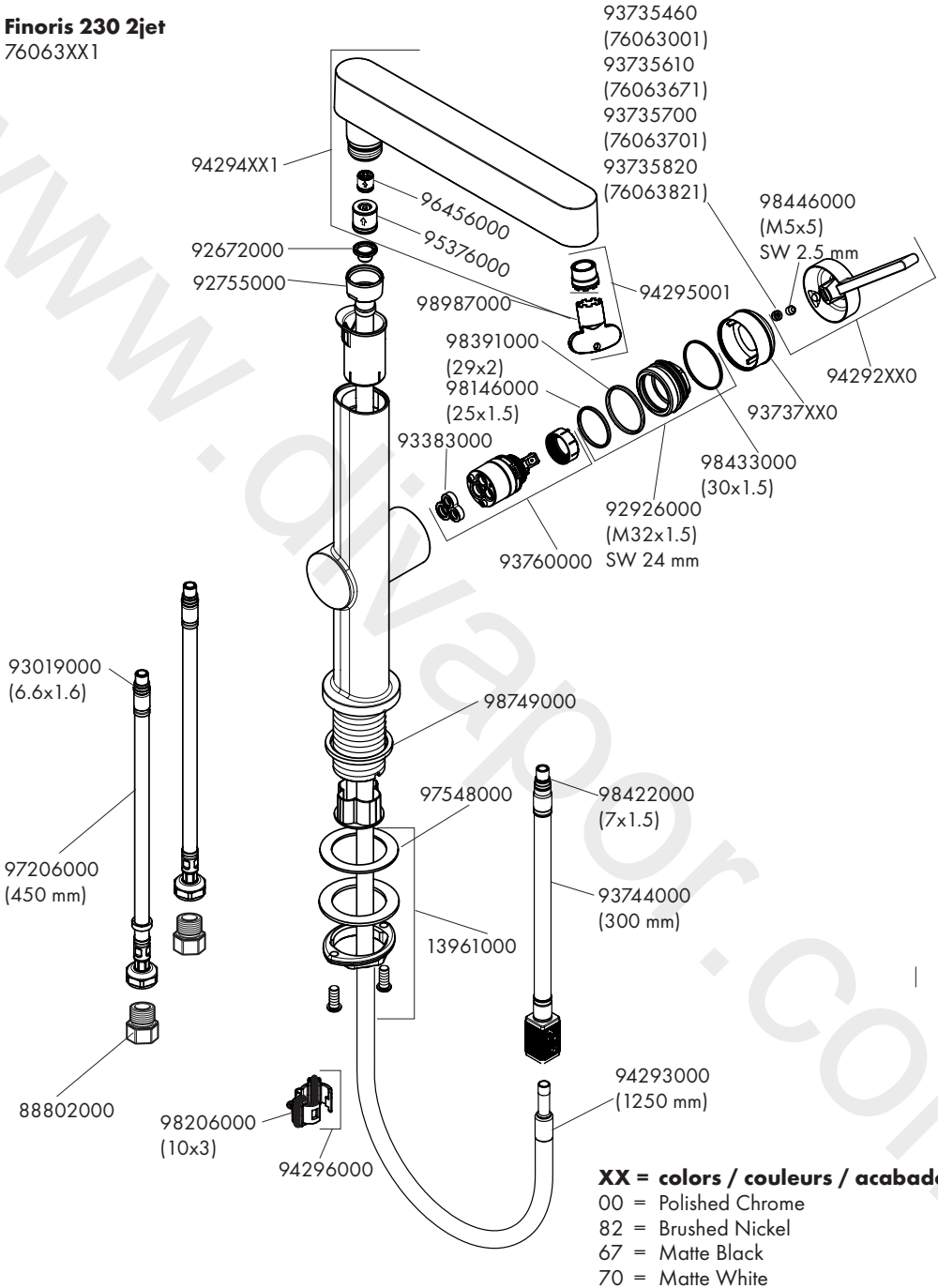

Maintenance / Maintenance / Mantenimiento

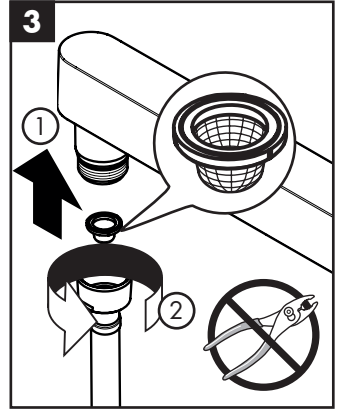
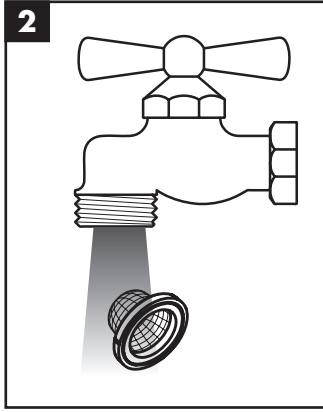
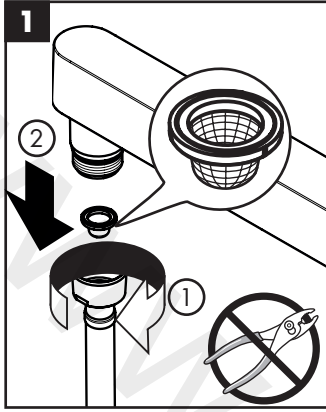

Check valve maintenance / Entretien de les clapets anti-retour/ Mantenimiento de las válvulas antirretornos

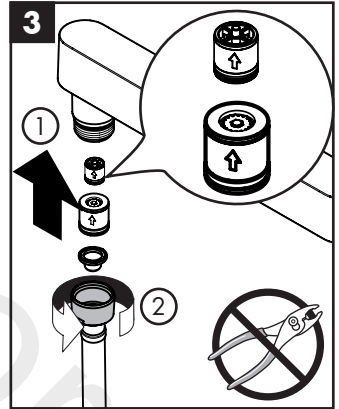
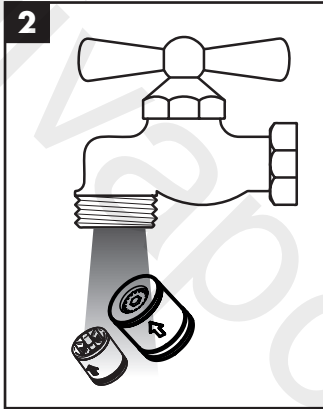
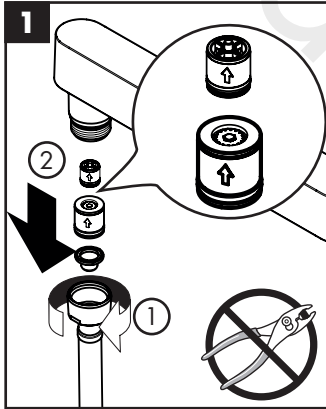

User Instructions / Instructions de service / Manejo

on
ouvert
abierto

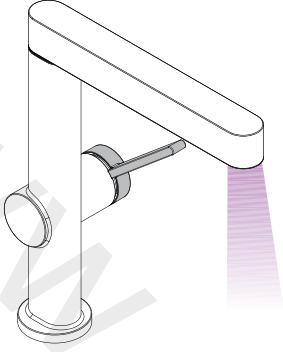

off
fermé
cerrar

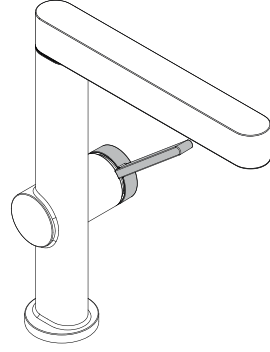

hot
chaud
caliente

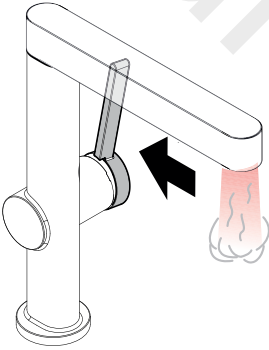

cold
froid
frío

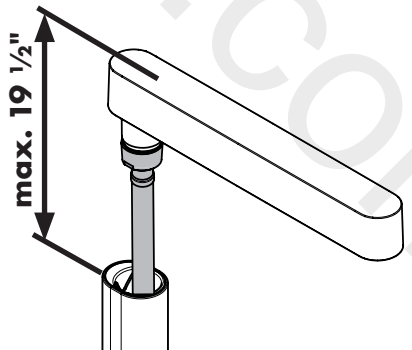
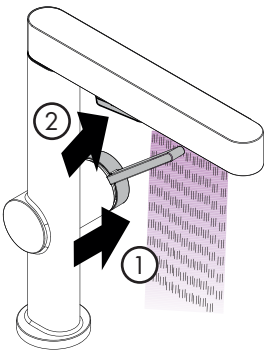
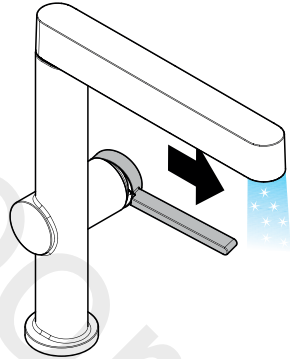

Cleaning Recommendation for Hansgrohe Products

Modern bathroom faucets, kitchen faucets and shower products are made from different materials to comply with the needs of the market with regard to design and functionality. To avoid damage to the product, it is necessary to take proper care of it.

For best results:

- Prevent the buildup of mineral scale and /or soap residue by cleaning your Hansgrohe product(s) when needed.
- Select a cleaning agent specifically intended for the type of product.
- **Do not** use these types of cleaners as they will cause damage to your Hansgrohe product:
 - ✗ Any cleaning agent containing hydrochloric acid, formic acid, lye, or acetic acid.
 - ✗ Abrasive cleaning powders, pads, or brushes.
 - ✗ Steam cleaners.
 - ✗ "No rinse" cleaning agents.
- **Always** follow the instructions provided by the manufacturer of the cleaning agent.
- **Do not** mix cleaning agents, unless directed by the manufacturer.
- **Do not** spray cleaners directly onto the product as drops could enter openings and gaps and cause damage. When using spray cleaners, spray the cleaner onto a soft cloth or sponge.
- **Always** rinse your Hansgrohe product thoroughly with clear water and polish dry with a soft cloth after cleaning.

Important

- Residue from soaps and shampoos can cause damage. Rinse the product with clean water after each use.
- Residue from basin/tub/tile cleaner can cause damage to faucets and fittings. Immediately rinse any overspray from the Hansgrohe product.
- **Do not** store any cleaning agents under your Hansgrohe product, such as in a vanity unit, as the fumes may damage the product.
- **Damage to the product caused by improper care or the use of improper cleaning agents is not covered by the warranty.**
- **If a component of the product is damaged, replace it, as there is risk of injury.**

Conseil de nettoyage pour les produits Hansgrohe

Les robinets pour les salles de bains et les cuisines modernes ainsi que les produits récents pour les douches se composent de matériaux différents afin de satisfaire aux besoins du marché en termes de conception et de fonctionnalité. Afin d'éviter d'endommager le produit, il est nécessaire d'en prendre soin.

Pour de meilleurs résultats :

- Empêchez l'accumulation de tarte et/ou de résidu de savon en nettoyant votre produit Hansgrohe lorsque c'est nécessaire.
- Sélectionnez un produit de nettoyage spécifiquement prévu pour ce type de produit.
- **N'utilisez pas** ces types de nettoyeurs car ils peuvent endommager votre produit Hansgrohe :
 - ✗ Tout produit de nettoyage contenant de l'acide chlorhydrique, de l'acide formique, de la potasse ou de l'acide acétique.
 - ✗ Les poudres de nettoyage, les tampons ou les brosses abrasives.
 - ✗ Les nettoyeurs à vapeur.
 - ✗ Les produits de nettoyage « sans rinçage ».
- **Ne mélangez pas** les produits de nettoyage, à moins que cela soit indiqué par le fabricant.
- **Ne pulvérisiez pas** les nettoyeurs directement sur le produit car des gouttes pourraient entrer dans les ouvertures et les fentes et causer des dommages. Lorsque vous utilisez des nettoyeurs par pulvérisation, pulvérisez le nettoyeur sur un chiffon ou une éponge douce.
- Après le nettoyage rincer abondamment à l'eau claire pour éliminer intégralement les restes de détergent.

Important

- Les residus de produits pour le corps comme les savons liquides, shampoings, gels de douche, teintures pour cheveux, parfums, apres-rasage et vernis a ongles peuvent causer des deteriorations. Rincez le produit avec de l'eau propre après chaque utilisation.
- Le résidu provenant des nettoyeurs pour cuvette/baignoire/carrelage peut endommager les robinets et les raccords de tuyauterie. Rincez immédiatement toute surpulvérisation sur le produit Hansgrohe.
- De meme, il est interdit de stocker des detergents ou des produits chimiques sous les produits, par ex. dans un meuble sous lavabo, car les vapeurs qui s'en degagent risquent d'abimer les produits.
- **Les dommages au produit causés par un mauvais entretien ou par l'utilisation de produits de nettoyage inadéquats ne sont pas couverts par la garantie.**
- **Si un composant du produit est endommagé, remplacez-le, car il existe un risque de blessure.**

Recomendación de limpieza para los productos de Hansgrohe

Hoy en día, las griferías de baño y de cocina así como duchas modernas se componen de materiales muy distintos para satisfacer las exigencias del mercado respecto al diseño y la funcionalidad. Para evitar daños y reclamaciones hay que tener en cuenta ciertos aspectos tanto en el uso como en su limpieza.

Para obtener mejores resultados:

- Evite la acumulación de restos de jabón o sarro limpiando el producto Hansgrohe cuando sea necesario.
- Seleccione un agente de limpieza diseñado específicamente para el tipo de producto.
- **No** use estos tipos de limpiadores, ya que causarán daño a su producto Hansgrohe:
 - ✗ Agentes limpiadores que contengan ácido clorhídrico, fórmico, acético o lejía.
 - ✗ Alavos, paños o cepillos de limpieza abrasivos.
 - ✗ Limpiadores a vapor
 - ✗ Agentes de limpieza "sin enjuague".
- **Siempre** siga las instrucciones provistas por el fabricante del agente de limpieza.
- **No** mezcle los agentes de limpieza, a menos que esté indicado por el fabricante.
- **No** rocíe limpiadores directamente sobre el producto, ya que podrían caer gotas sobre las aberturas y espacios y causar daños. Cuando use limpiadores en spray, rocíe el limpiador sobre un paño suave o esponja.
- **Siempre** enjuague su producto Hansgrohe con agua limpia y séquelo y lústrela con un paño suave después de la limpieza.

Importante

- Los residuos de productos de aseo como jabon liquido, champus, gel de ducha, tintes de pelo, perfumes, lociones de afeitado y esmalte de unas pueden danar tambien los materiales. Enjuague el producto con agua limpia después de cada uso.
- Los residuos de limpiadores para lavatorios, bañeras o azulejos pueden causar daño a los grifos y accesorios. Enjuague inmediatamente cualquier derrame que haya sobre el producto de Hansgrohe.
- Tampoco pueden generarse depositos de productos de limpieza o quimicos debajo de los productos, p. ej. En un armario de lavabo. De lo contrario, los vapores generados pueden danar los productos.
- **Los daños que resulten de un cuidado inadecuado o uso de agentes de limpieza inadecuados no están cubiertos por la garantía.**
- **Si se daña un componente del producto, reemplázelo, ya que existe riesgo de lesión.**

www.divapor.com

Hansgrohe, Inc. Limited Warranty

Offering our customers the highest quality at all times is a fundamental part of the Hansgrohe, Inc. company philosophy. We offer consumers a limited warranty on our hansgrohe® and AXOR® branded products.

This warranty is limited to products manufactured by Hansgrohe, Inc. that are purchased from a Hansgrohe, Inc. authorized seller by a consumer in the United States or Canada after September 1, 2019, and installed in either the United States or in Canada.

WARRANTY

Hansgrohe, Inc. warrants to the original consumer purchaser that hansgrohe and AXOR products will be free from defects in material and workmanship for as long as the original consumer purchaser owns both the product and the home in which the product was originally installed. For commercial purchasers, the warranty period is (a) one (1) year for hansgrohe products and (b) five (5) years for AXOR products, in each case from the date of purchase. The warranty period for products in the Rubbed Bronze, Matte Black and Matte White finishes are three (3) years from the date of purchase. This warranty is non-transferable.

WHAT WE WILL DO

Hansgrohe, Inc., at its option, will replace any product or part of the product that proves defective in workmanship and/or material, under normal installation, use, service and maintenance. If Hansgrohe, Inc. is unable to provide a replacement part or product and repair is not practical or cannot be made in timely fashion, Hansgrohe, Inc. may elect to refund the purchase price in exchange for the return of the defective product. REPAIR OR REPLACEMENT (OR, IN LIMITED CIRCUMSTANCES, REFUND OF THE PURCHASE PRICE) AS PROVIDED UNDER THIS LIMITED WARRANTY IS THE EXCLUSIVE REMEDY OF THE PURCHASER.

WHAT IS NOT COVERED BY THE WARRANTY

Because Hansgrohe, Inc. is unable to control the quality of hansgrohe or AXOR products sold by unauthorized sellers, unless otherwise prohibited by law, this warranty does not cover hansgrohe or AXOR products purchased from unauthorized sellers. Authorized sellers can be found on hansgrohe and AXOR branded websites.

Labor and other expenses for disconnection, deinstallation, or return of the product for warranty service (including but not limited to proper packaging and shipping costs), or for installation or reinstallation of the product are not covered by this warranty.

Hansgrohe, Inc. shall not be liable for any damage to the product resulting from

- reasonable wear and tear
- outdoor use
- misuse (including use of the product for an unintended application)
- freezing water
- excessive water pressure
- pipe corrosion in the home in which the product is installed

- abuse, neglect or improper or incorrectly performed installation, maintenance or repair, including the use of abrasive or caustic cleaning agents or “no-rinse” cleaning products.

This warranty does not cover: (i) accessories, connected materials and products, or related products not manufactured by Hansgrohe, Inc. (ii) any hansgrohe or AXOR product sold for display purposes or (iii) hansgrohe or AXOR products purchased from unauthorized sellers.

WHAT YOU MUST DO TO OBTAIN WARRANTY SERVICE OR INFORMATION

Contact your retailer, or contact Technical Service at:

Hansgrohe, Inc.
1492 Bluegrass Lakes Parkway
Alpharetta, GA 30004
Toll-free 800 -334- 0455

In requesting warranty service, you will need to provide:

1. The sales receipt or other evidence of the date and place of purchase.
2. A description of the problem.
3. Delivery of the product or the defective part, postage prepaid and carefully packed and insured, to:

Hansgrohe, Inc.
1492 Bluegrass Lakes Parkway
Alpharetta, GA 30004
Toll-free 800 -334- 0455

When warranty service is completed, any repaired or replacement product or part will be returned to you postage prepaid.

REVISED SEPTEMBER 1, 2019.

Limitation on Duration of Implied Warranties: Some States do not allow limitations on how long an implied warranty lasts, so the below limitations may not apply to you. TO THE MAXIMUM EXTENT PERMITTED BY APPLICABLE LAW, ANY IMPLIED WARRANTY, INCLUDING THE IMPLIED WARRANTIES OF MERCHANTABILITY AND OF FITNESS FOR A PARTICULAR PURPOSE, IS LIMITED TO THE STATUTORY PERIOD OR THE DURATION OF THIS WARRANTY, WHICHEVER IS SHORTER.

Limitation of Special, Incidental or Consequential Damages: Some States do not allow the exclusion or limitation of incidental or consequential damages, so the below limitations and exclusions may not apply to you. TO THE MAXIMUM EXTENT PERMITTED BY APPLICABLE LAW, THIS WARRANTY DOES NOT COVER, AND HANSGROHE, INC. SHALL NOT BE LIABLE FOR, ANY SPECIAL, INCIDENTAL OR CONSEQUENTIAL DAMAGES (INCLUDING LABOR CHARGES TO REPAIR, REPLACE, INSTALL OR REMOVE THIS PRODUCT), WHETHER ARISING OUT OF BREACH OF ANY EXPRESS OR IMPLIED WARRANTY, BREACH OF CONTRACT, TORT, OR OTHERWISE. HANSGROHE, INC. SHALL NOT BE LIABLE FOR ANY DAMAGE TO THE PRODUCT RESULTING

FROM REASONABLE WEAR AND TEAR, OUTDOOR USE, MISUSE (INCLUDING USE OF THE PRODUCT FOR AN UNINTENDED APPLICATION), FREEZING WATER, EXCESSIVE WATER PRESSURE, PIPE CORROSION IN THE HOME IN WHICH THE PRODUCT IS INSTALLED, ABUSE, NEGLIGENCE OR IMPROPER OR INCORRECTLY PERFORMED INSTALLATION, MAINTENANCE OR REPAIR, INCLUDING THE USE OF ABRASIVE OR CAUSTIC CLEANING AGENTS OR "NO-RINSE" CLEANING PRODUCTS.

Notice to residents of the State of New Jersey: The provisions of this warranty, including its limitations, are intended to apply to the fullest extent permitted by the laws of the State of New Jersey.

This warranty gives you specific legal rights, and you may also have other rights which vary from state to state.

PRODUCT INSTRUCTIONS AND QUESTIONS

Upon purchase or prior to installation, please carefully inspect your product for any damage or visible defect. Prior to installing, always carefully study the enclosed instructions on the proper installation and the care and maintenance of this product.

If you have questions at any time about the use, installation or performance of your product, or the Limited Warranty, please write us or call us toll-free at 800-334-0455.

hansgrohe

Hansgrohe, Inc. 1490 Bluegrass Lakes Parkway Alpharetta, GA 30004
Tel. 800-334-0455 Fax 770-889-1783

www.hansgrohe-usa.com