

DE Gebrauchsanleitung / Montageanleitung

EN Instructions for use / assembly instructions

2

3

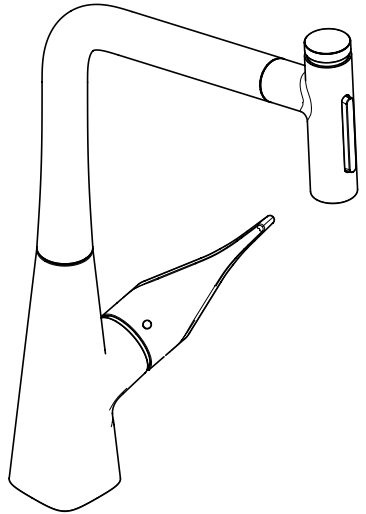

Metris Select M71 320 2jet sBox
73816003



Sicherheitshinweise

- ⚠ Bei der Montage müssen zur Vermeidung von Quetsch- und Schnittverletzungen Handschuhe getragen werden.
- ⚠ Große Druckunterschiede zwischen den Kalt- und Warmwasseranschlüssen müssen ausgeglichen werden.

Montagehinweise

- Vor der Montage muss das Produkt auf Transportschäden untersucht werden. Nach dem Einbau werden keine Transport- oder Oberflächenschäden anerkannt.
- Die Leitungen und die Armatur müssen nach den gültigen Normen montiert, gespült und geprüft werden.
- Die in den Ländern jeweils gültigen Installationsrichtlinien sind einzuhalten.
- Bei Erstinbetriebnahme und nach Wartungsarbeiten kann es durch Luft in der Armatur zu einem Geräusch kommen. Nach ca. 15 Aktivierungen der Armatur ist das Geräusch verschwunden.

Technische Daten

Betriebsdruck: max. 1 MPa
 Empfohlener Betriebsdruck: 0,1 - 0,5 MPa
 Prüfdruck: 1,6 MPa
 (1 MPa = 10 bar = 147 PSI)

Heißwassertemperatur: max. 70 °C
 Empfohlene Heißwassertemperatur: 65 °C
 Thermische Desinfektion: max. 70 °C / 4 min

Das Produkt ist ausschließlich für Trinkwasser konzipiert!

Symbolerklärung

 Kein essigsäurehaltiges Silikon verwenden!

Justierung (siehe Seite 11)

Einstellen der Warmwasserbegrenzung. In Verbindung mit Durchlauferhitzern ist eine Warmwassersperre nicht zu empfehlen.

Maße (siehe Seite 18)

Durchflussdiagramm (siehe Seite 18)

Wartung (siehe Seite 14)

Rückflussverhinderer müssen gemäß DIN EN 1717 regelmäßig in Übereinstimmung mit nationalen oder regionalen Bestimmungen auf ihre Funktion geprüft werden (mindestens einmal jährlich).

Reinigung (siehe Seite 13)

Serviceteile (siehe Seite 16)

Sonderzubehör

(nicht im Lieferumfang enthalten)

F12 Verlängerung #43333000 (siehe Seite 16 / 17)

Bedienung (siehe Seite 12)

- Hansgrohe empfiehlt, morgens oder nach längeren Stagnationszeiten den ersten halben Liter nicht als Trinkwasser zu verwenden.
- Beim Öffnen der Armatur über den Hebelgriff kann kurzzeitig minimal Wasser am Auslauf austreten.
- Über den Hebelgriff wird die Armatur geöffnet und die gewünschte Temperatur eingestellt. Durch den stirnseitig am Auslauf befindlichen Select-Knopf kann der Wasserfluss pausiert werden. Bei längerer Nichtverwendung, z. B. über Nacht oder bei Verlassen des Hauses, muss die Armatur über den Hebelgriff vollständig geschlossen werden.

Störung	Ursache	Abhilfe
Armatur schwergängig	- Kartusche defekt, verkalkt	- Kartusche austauschen
Armatur tropft	- Kartusche defekt	- Kartusche austauschen
Wasseraustritt am Befestigungsschaft	- Anschlussschläuche nicht ganz in den Grundkörper eingeschraubt - O-Ring am Anschlussschlauch defekt	- Anschlussschläuche von Hand festziehen - O-Ring austauschen
Zu niedrige Warmwassertemperatur	- Warmwasserbegrenzung falsch eingestellt	- Warmwasserbegrenzung einstellen
Geringer Durchfluss mit geöffneten Select-Ventil nach dem Tausch des Ventils	- Falsches Select-Ventil verbaut	- Select-Ventil austauschen (#98463000)
Select-Knopf schwergängig	- Select-Knopf verschmutzt	- Select-Knopf reinigen und O-Ring (#9820100) fetten



Safety Notes

- △ Gloves should be worn during installation to prevent crushing and cutting injuries.
- △ The hot and cold supplies must be of equal pressures.

Installation Instructions

- Prior to installation, inspect the product for transport damages. After it has been installed, no transport or surface damage will be honoured.
- The pipes and the fixture must be installed, flushed and tested as per the applicable standards.
- The plumbing codes applicable in the respective countries must be observed.
- During initial start-up and after servicing, air in the fittings can cause noise. After switching the jet on and off about 15 times, the noise will stop.

Technical Data

Operating pressure: max. 1 MPa
 Recommended operating pressure: 0,1 - 0,5 MPa
 Test pressure: 1,6 MPa
 (1 MPa = 10 bar = 147 PSI)

Hot water temperature: max. 70°C
 Recommended hot water temp.: 65°C
 Thermal disinfection: max. 70°C / 4 min

The product is exclusively designed for drinking water!

Symbol description



Do not use silicone containing acetic acid!

Adjustment (see page 11)

To adjust the hot water limiter. Using a hot water limiter in combination with a continuous flow water heater is not recommended.



Dimensions (see page 18)

Flow diagram (see page 18)

Maintenance (see page 14)

The check valves must be checked regularly according to DIN EN 1717 in accordance with national or regional regulations (at least once a year).



Cleaning (see page 13)



Spare parts (see page 16)

Special accessories (order as an extra)



F12 extension #43333000 (see page 16 / 17)



Operation (see page 12)

- Hansgrohe recommends not to use as drinking water the first half liter of water drawn in the morning or after a prolonged period of non-use.
- Minor leaking may occur briefly at the spout when opening the fitting via the lever.
- Use the lever to open the tap and set the desired temperature. The water flow can be paused by pressing the Select button on the face side of the spout. When the tap is not used for a longer period of time, f.e. when retiring at night or leaving the house, it must be closed completely by means of the lever.

Fault	Cause	Remedy
Mixer stiff	- Cartridge defective, calcified	- Exchange cartridge
Mixer dripping	- Cartridge defective	- Exchange cartridge
Water escaping at the threaded base	- connection hoses not completely screwed into basic body - O-ring at the connection hose defective.	- Tighten connection hoses by hand - Exchange O-ring
Hot water temperature too low	- Hot water limiter incorrectly set	- Set hot water limiter
Low flow with Select valve after valve replacement	- Improper Select valve installed	- Replace Select valve (#98463000)
Select button stiff	- Select button soiled	- Clean Select button and grease (#9820100) O-ring

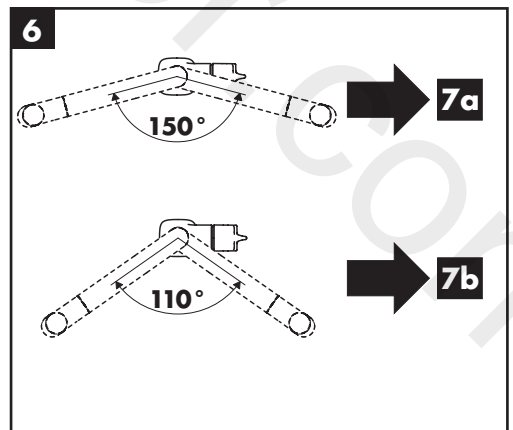
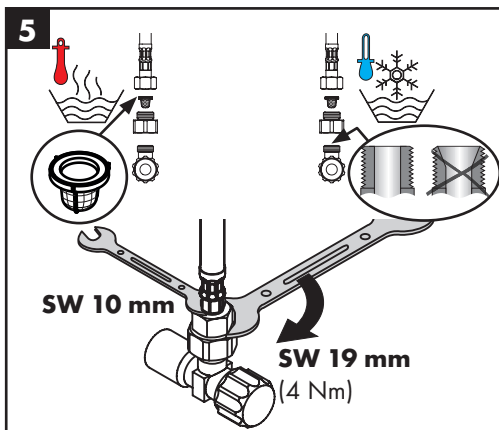
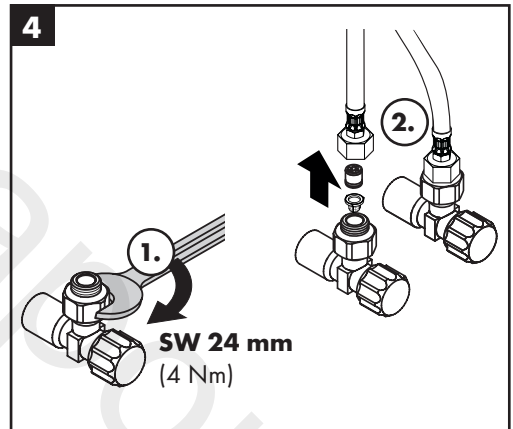
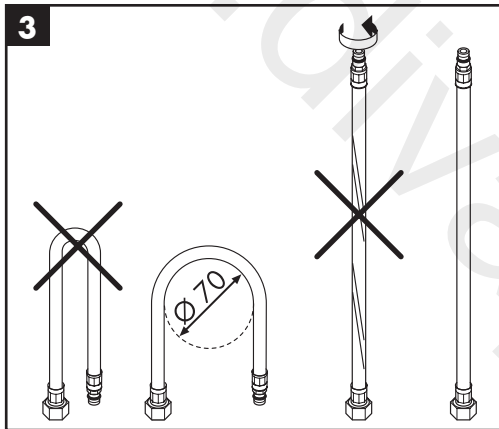
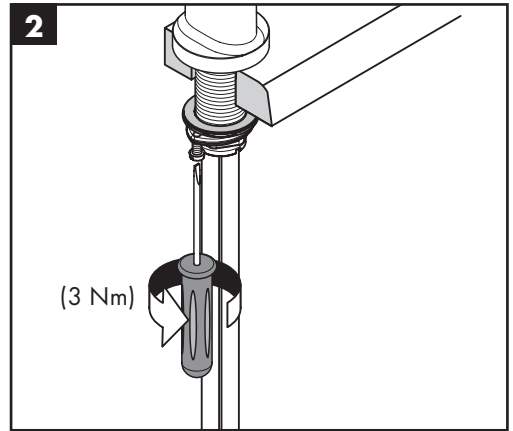
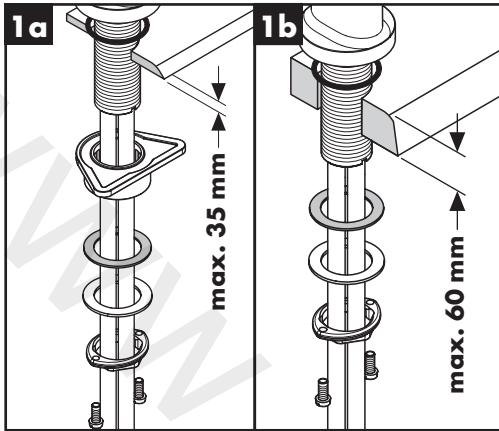



7a

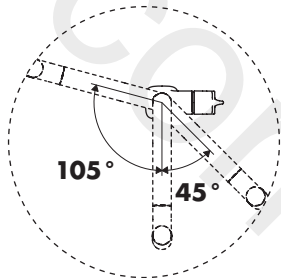
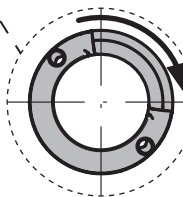
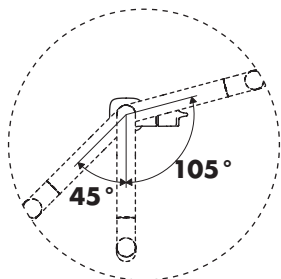
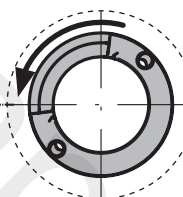
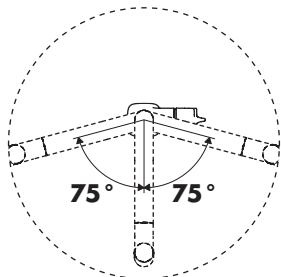
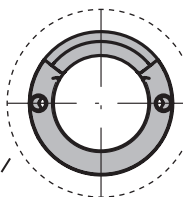
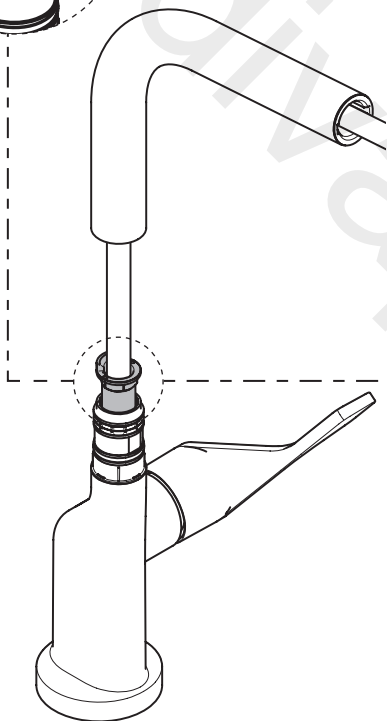
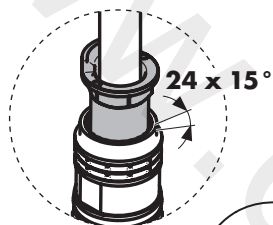
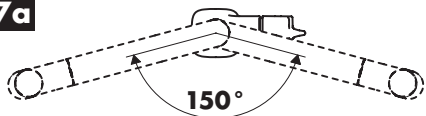



7b

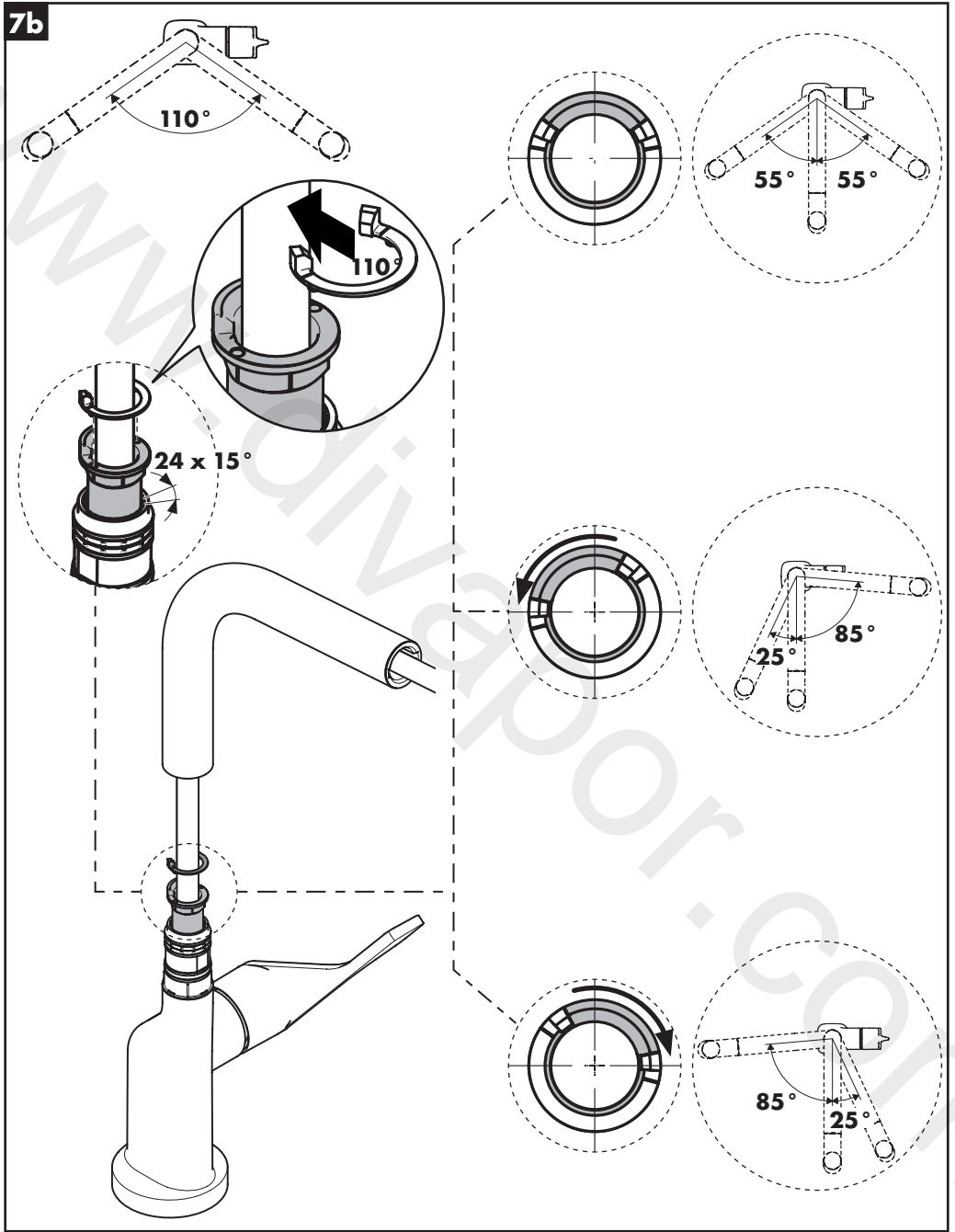

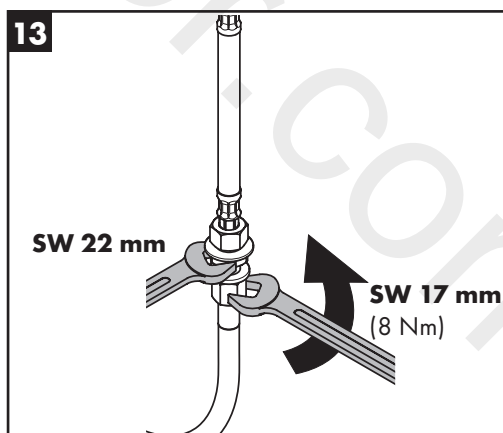
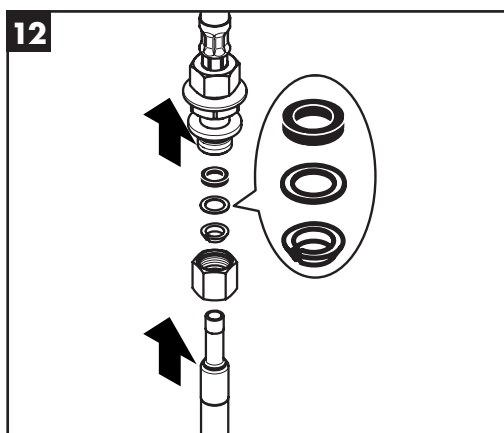
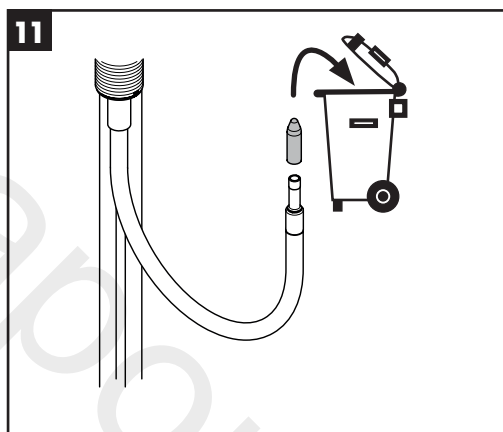
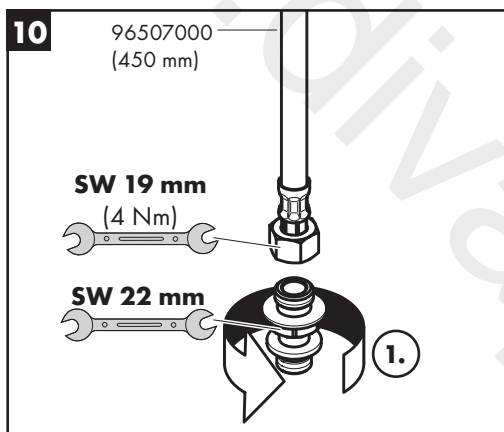
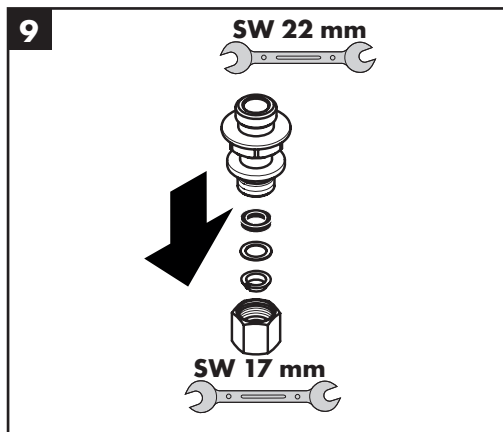
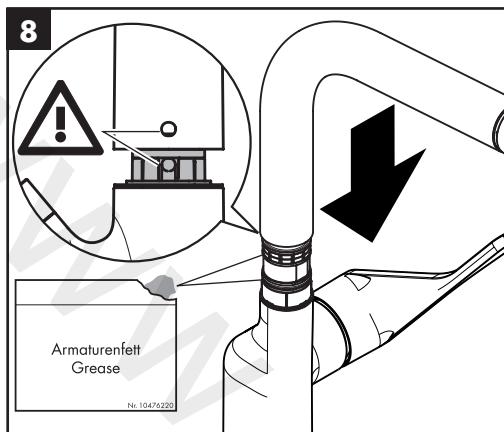

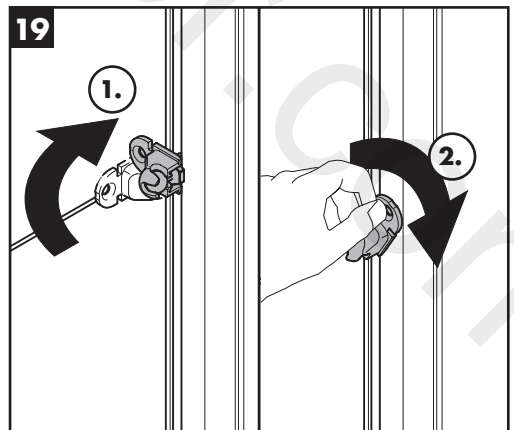
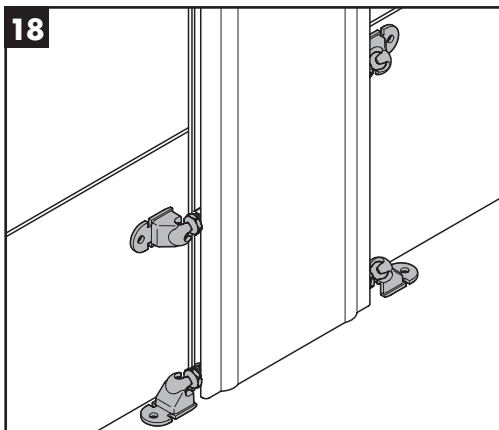
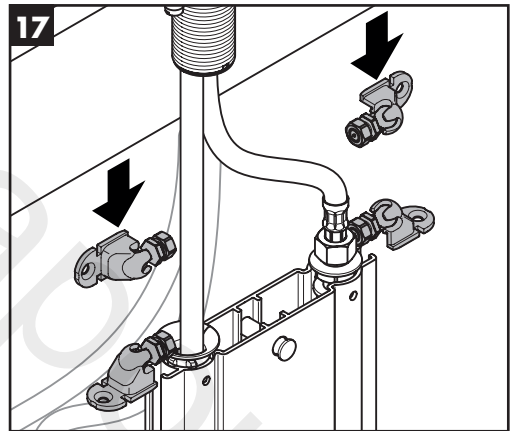
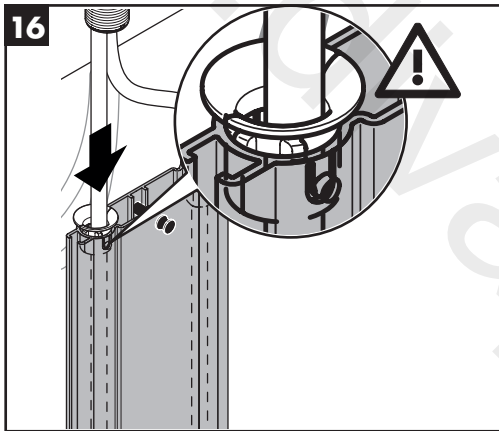
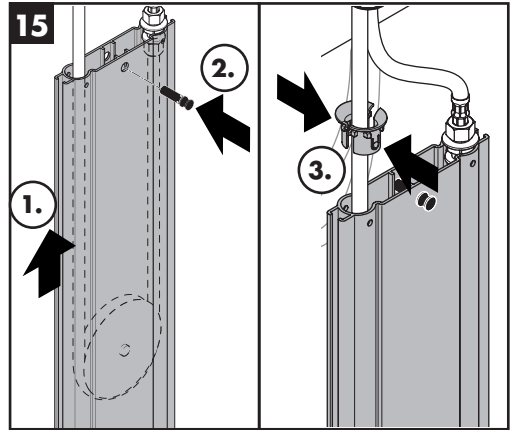
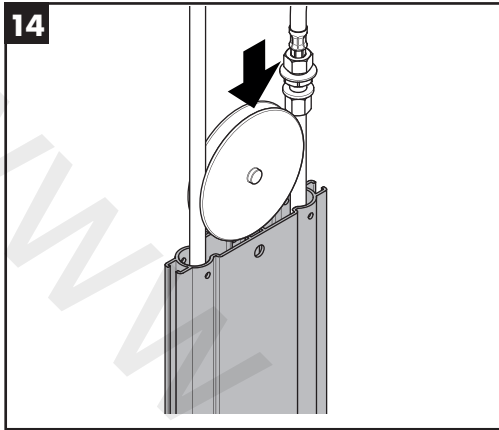

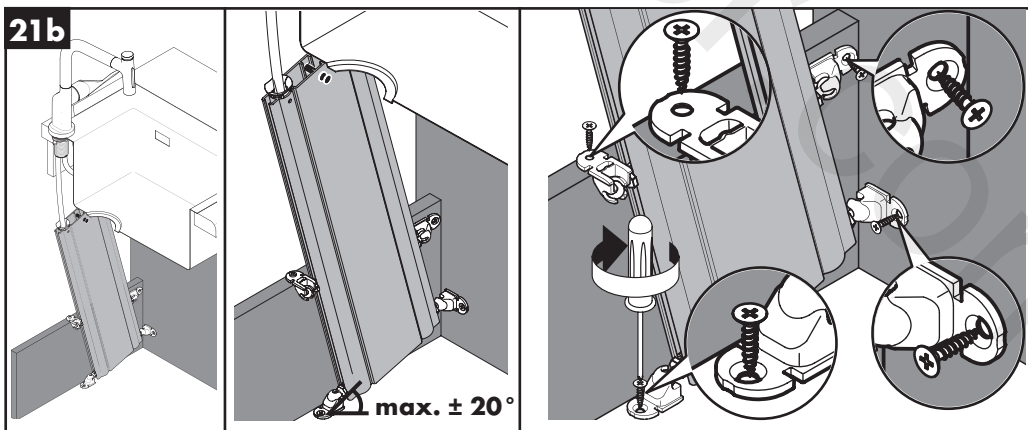
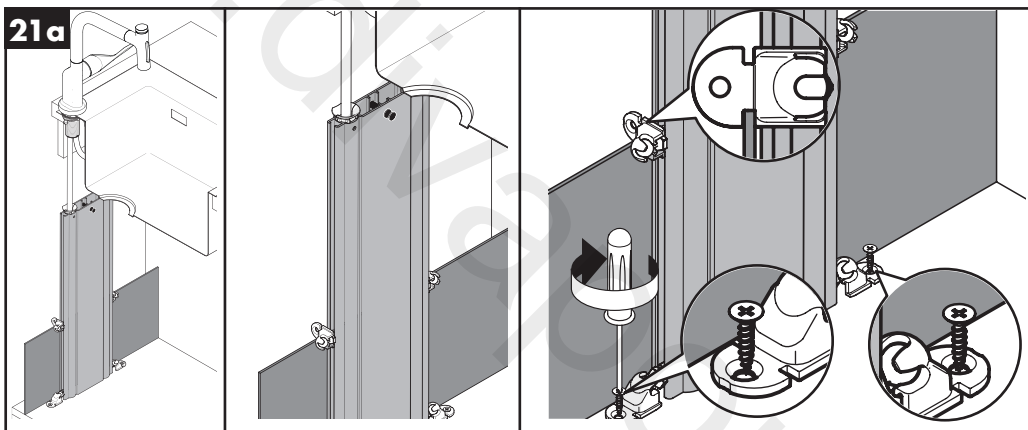
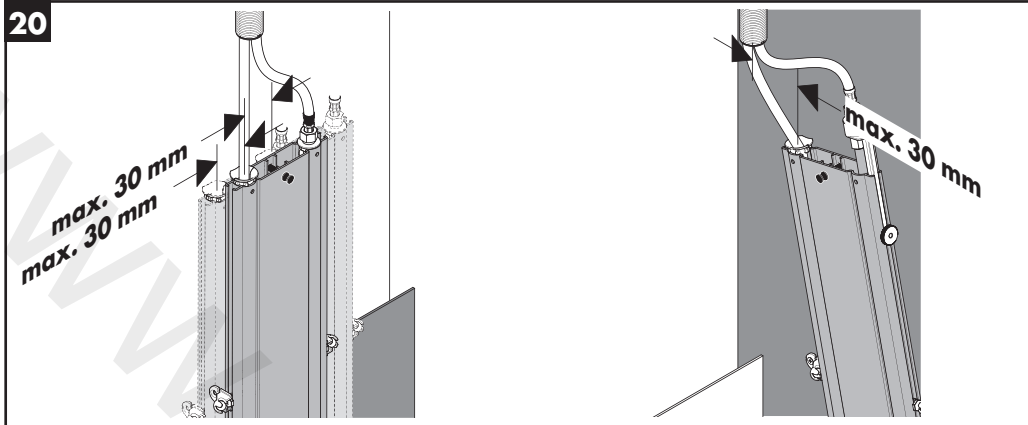

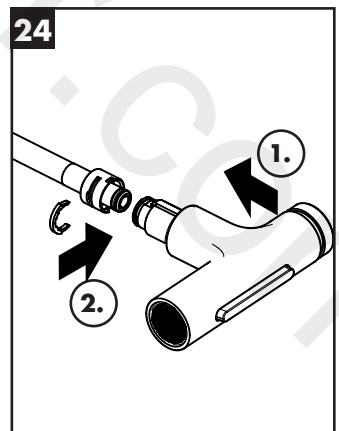
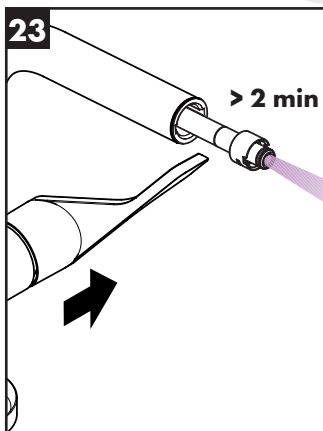
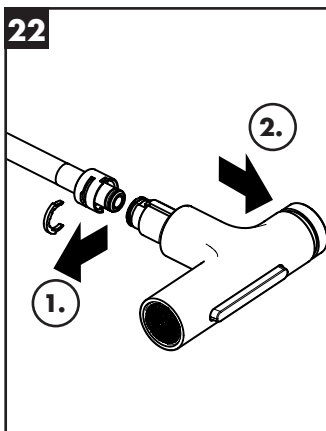
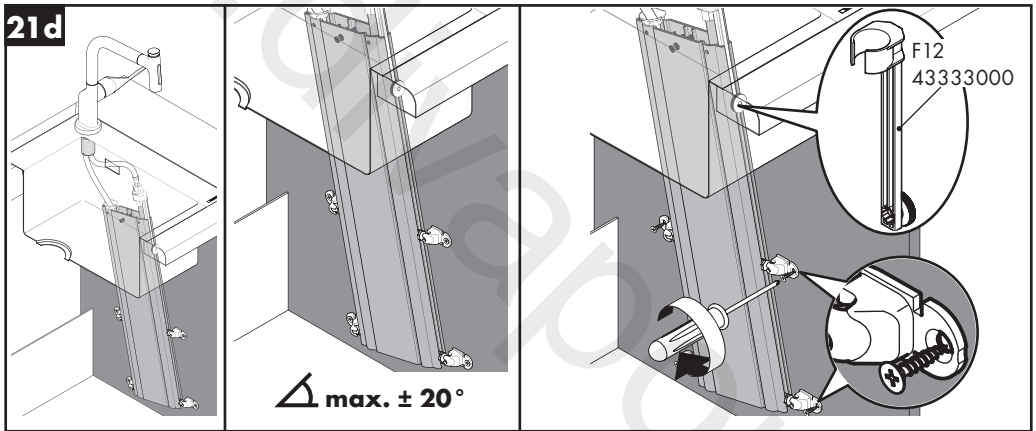
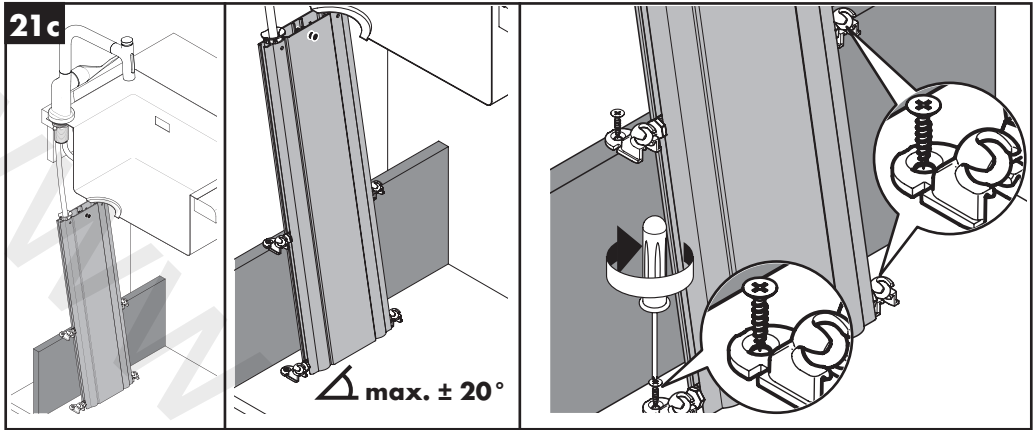

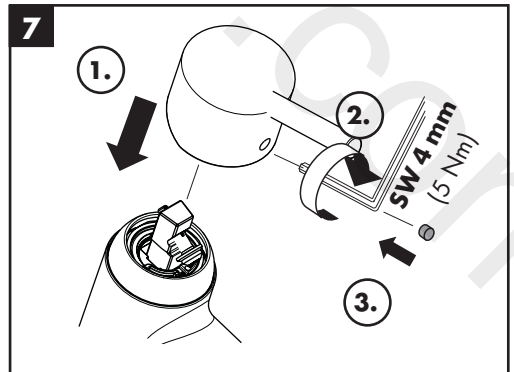
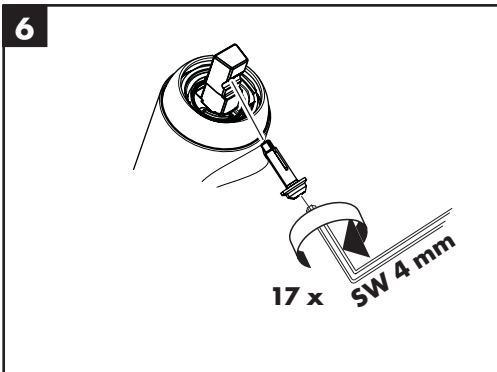
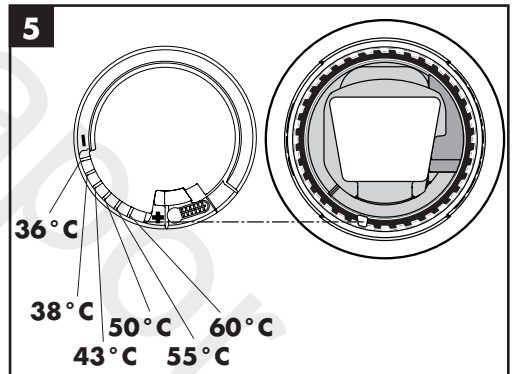
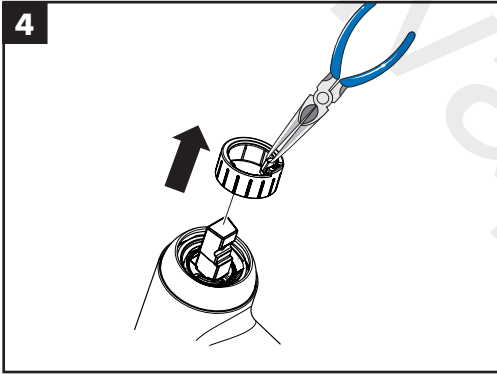
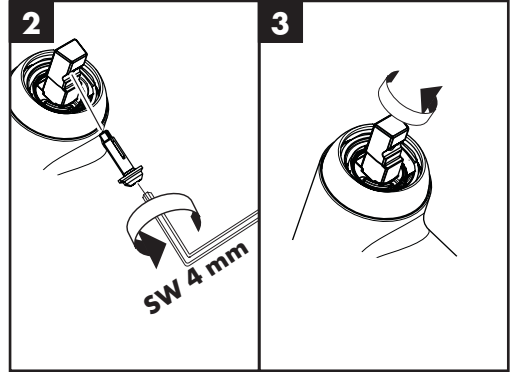
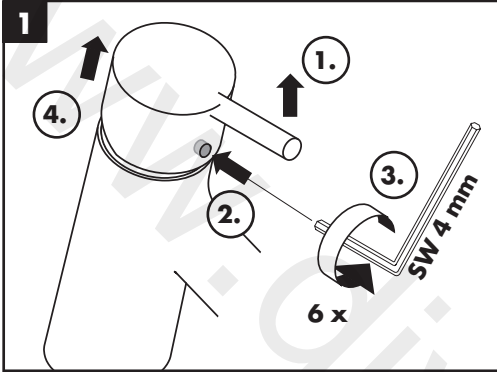

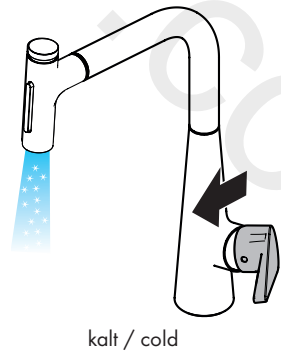
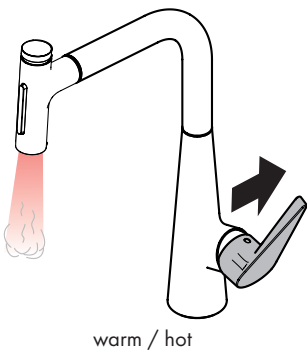
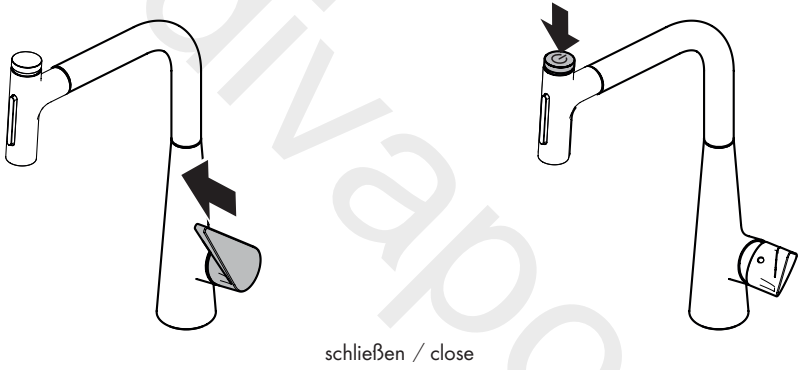
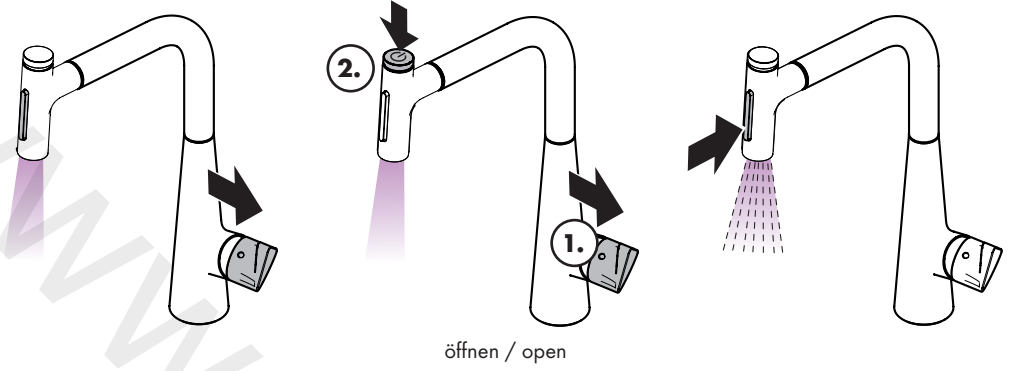



DE Reinigungsempfehlung / Garantie / Kontakt

EN Cleaning recommendation / Warranty / Contact



[www.hansgrohe.com/
cleaning-recommendation](http://www.hansgrohe.com/cleaning-recommendation)

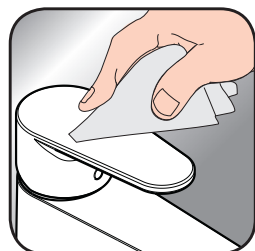

[www.hansgrohe.com/
cleaning-recommendation](http://www.hansgrohe.com/cleaning-recommendation)



[www.hansgrohe.com/
cleaning-recommendation](http://www.hansgrohe.com/cleaning-recommendation)



[www.hansgrohe.com/
cleaning-recommendation](http://www.hansgrohe.com/cleaning-recommendation)

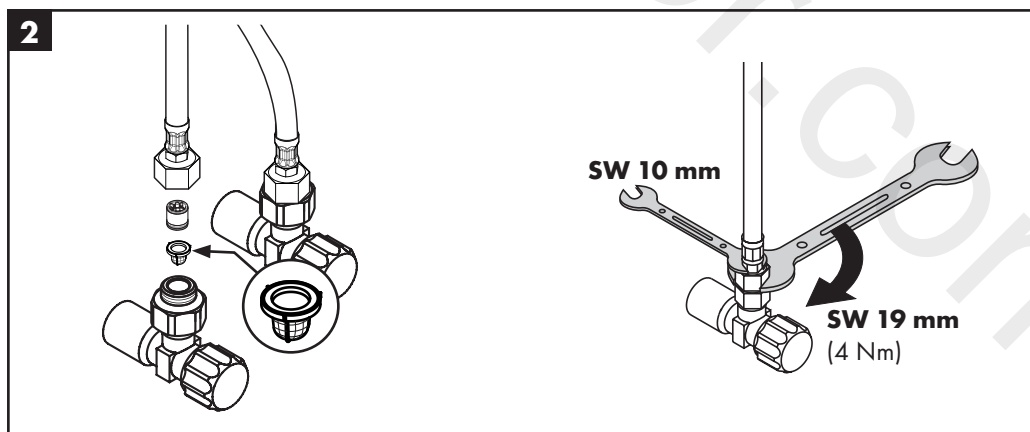
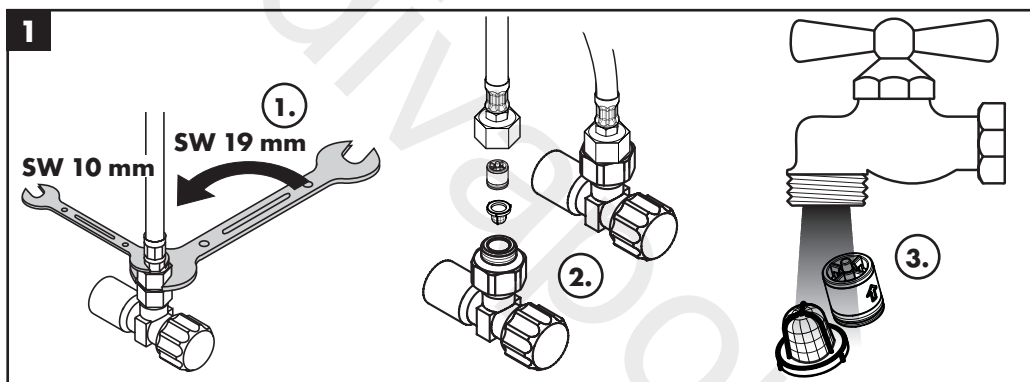
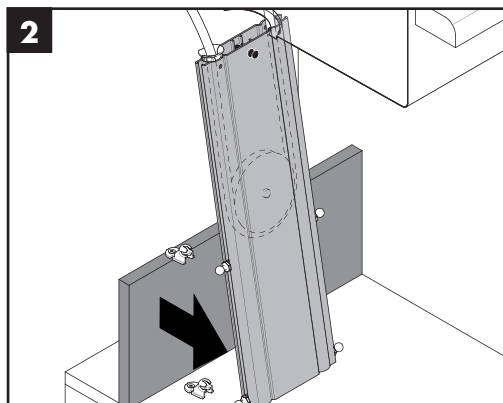
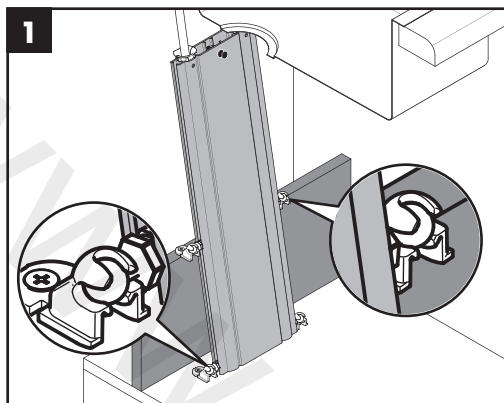

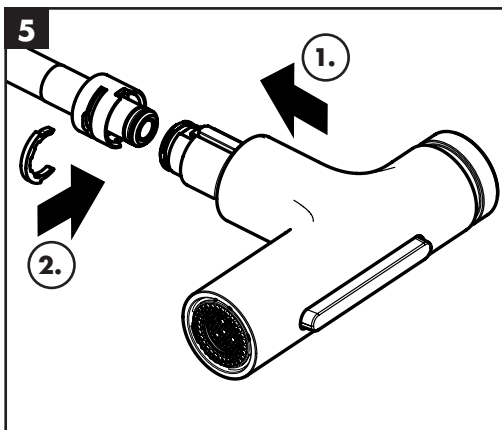
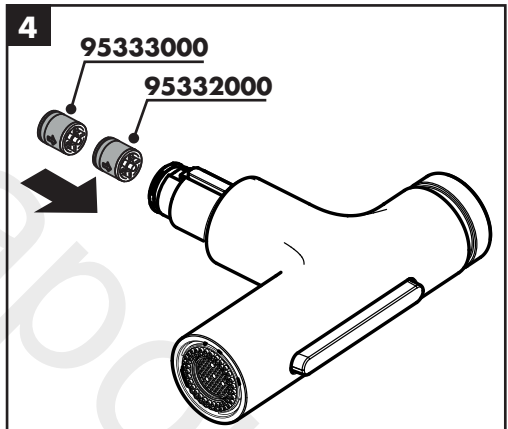
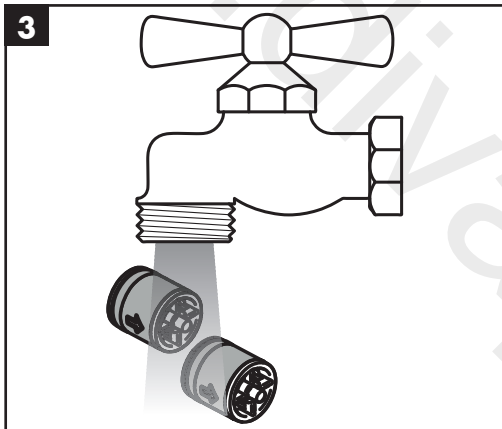
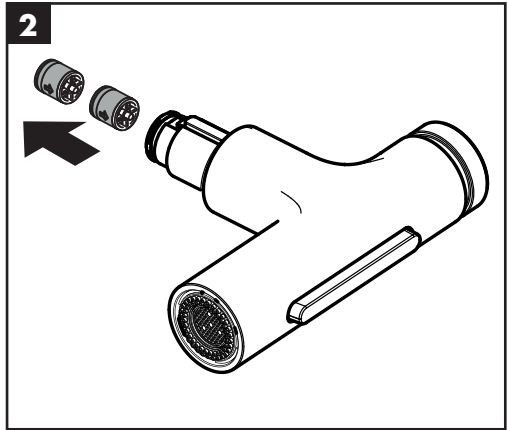
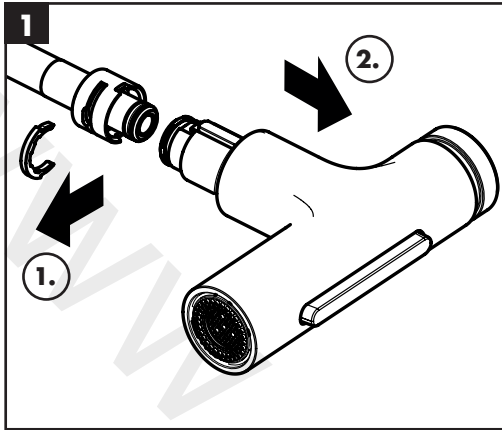

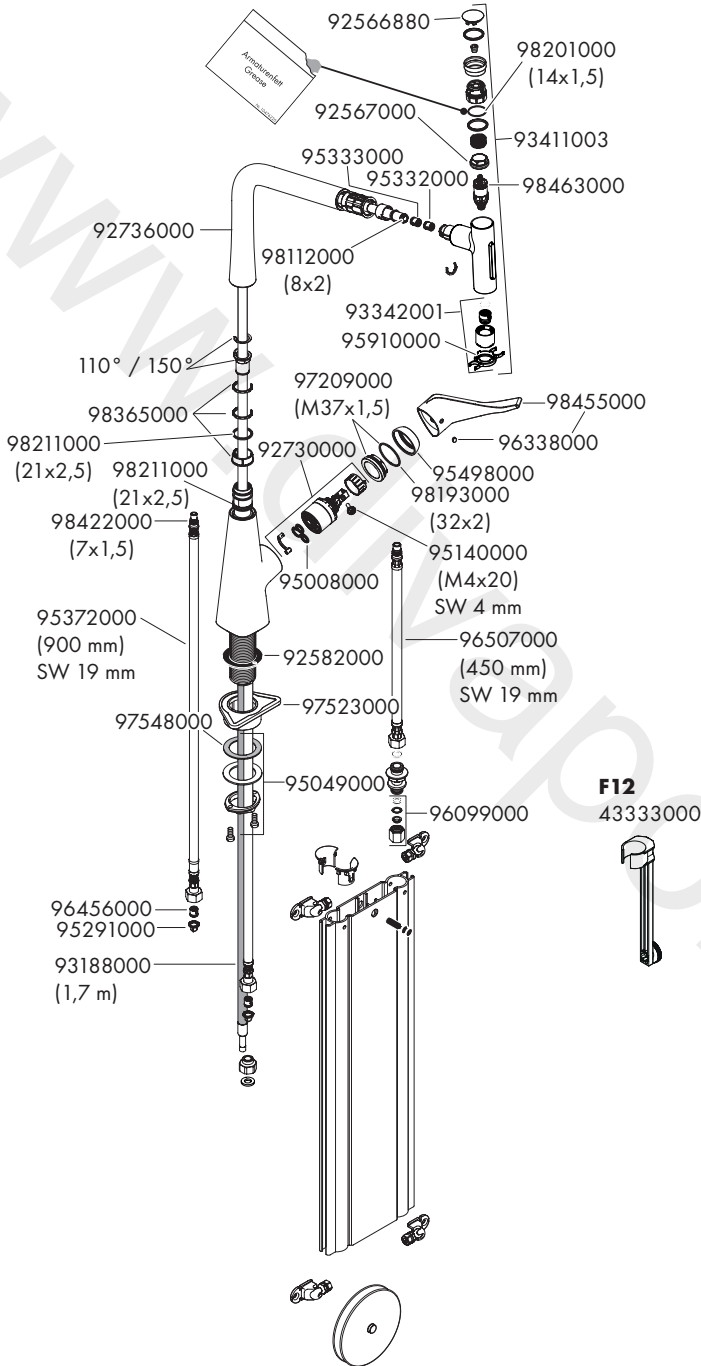

F12
43333000

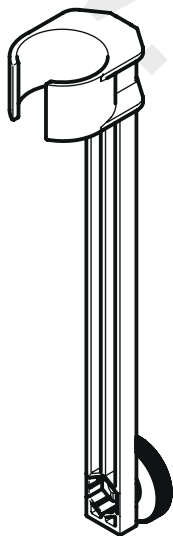

1

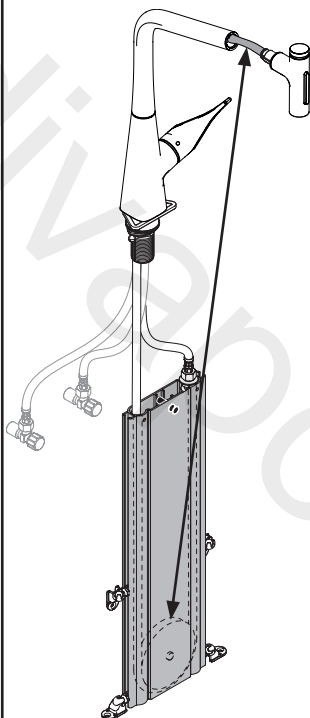

2

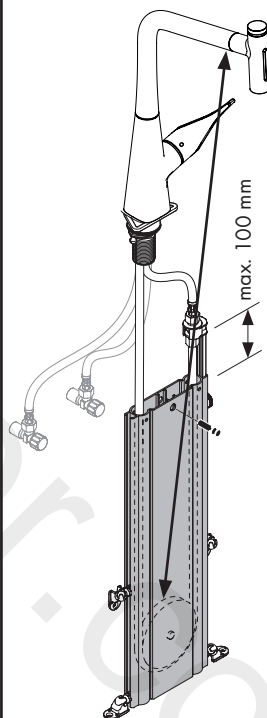

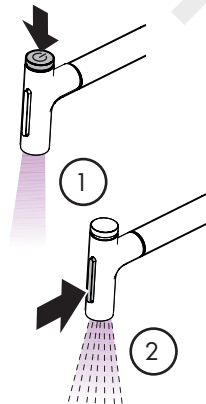
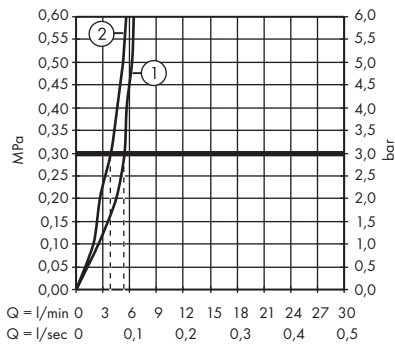
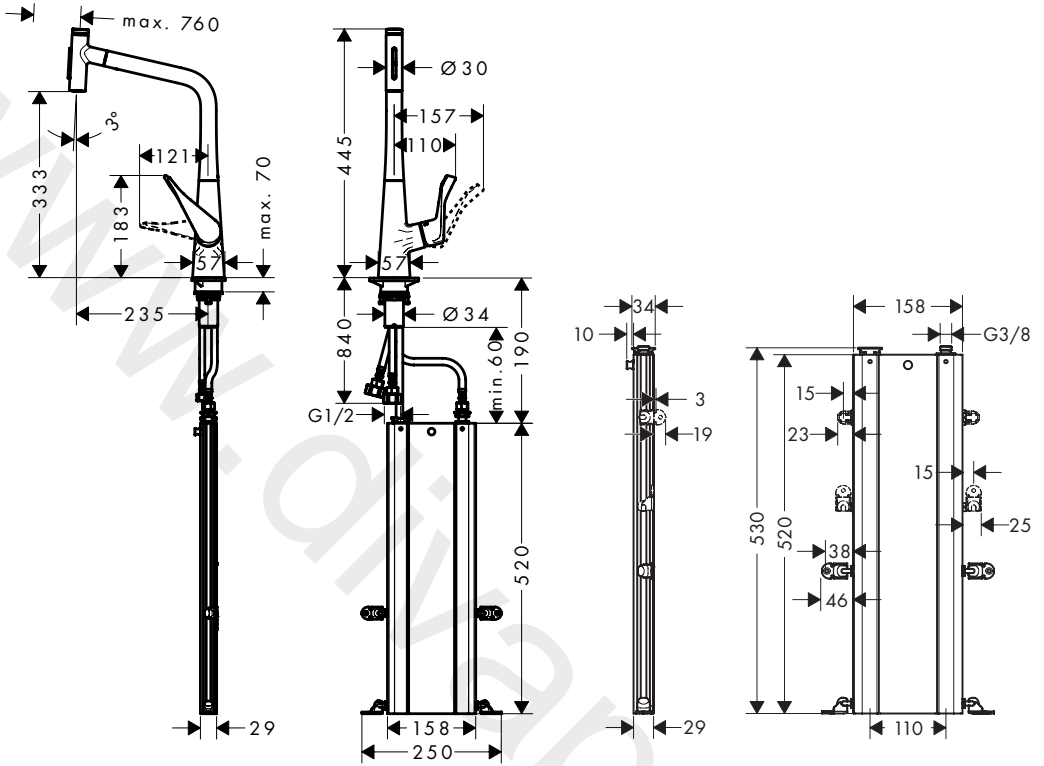

www.divapor.com

www.divapor.com

hansgrohe

Hansgrohe · AuestraÙe 5 · 9 · D-77761 Schiltach · Telefon +49 (0) 78 36/51-1282 · Telefax +49 (0) 7836/511440
E-Mail: info@hansgrohe.com · Internet: www.hansgrohe.com

11/2019
9.0593631