

<b>DE</b>	Gebrauchsanleitung / Montageanleitung	<b>2</b>
<b>FR</b>	Mode d'emploi / Instructions de montage	<b>2</b>
<b>EN</b>	Instructions for use / Assembly instructions	<b>3</b>
<b>IT</b>	Istruzioni per l'uso / Istruzioni per Installazione	<b>3</b>
<b>ES</b>	Modo de empleo / Instrucciones de montaje	<b>4</b>
<b>NL</b>	Gebruiksaanwijzing / Handleiding	<b>4</b>
<b>DK</b>	Brugsanvisning / Monteringsvejledning	<b>5</b>
<b>PT</b>	Instruções para uso / Manual de Instalação	<b>5</b>
<b>PL</b>	Instrukcja obsługi / Instrukcja montażu	<b>6</b>
<b>CS</b>	Návod k použití / Montážní návod	<b>6</b>
<b>SK</b>	Návod na použitie / Montážny návod	<b>7</b>
<b>ZH</b>	用户手册 / 组装说明	<b>7</b>
<b>RU</b>	Руководство пользователя / Инструкция по монтажу	<b>8</b>
<b>FI</b>	Käyttöohje / Asennusohje	<b>8</b>
<b>SV</b>	Bruksanvisning / Monteringsanvisning	<b>9</b>
<b>LT</b>	Vartotojo instrukcija / Montavimo instrukcijos	<b>9</b>
<b>HR</b>	Upute za uporabu / Uputstva za instalaciju	<b>10</b>
<b>RO</b>	Manual de utilizare / Instrucțiuni de montare	<b>10</b>
<b>EL</b>	Οδηγίες χρήσης / Οδηγία συναρμολόγησης	<b>11</b>
<b>SL</b>	Navodilo za uporabo / Navodila za montažo	<b>11</b>
<b>ET</b>	Kasutusjuhend / Paigaldusjuhend	<b>12</b>
<b>LV</b>	Lietošanas pamācība / Montāžas instrukcija	<b>12</b>
<b>SR</b>	Uputstvo za upotrebu / Uputstvo za montažu	<b>13</b>
<b>NO</b>	Bruksanvisning / Montasjeveiledning	<b>13</b>
<b>BG</b>	Инструкция за употреба / Ръководство за монтаж	<b>14</b>
<b>JP</b>	取扱説明書 / 施工説明書	<b>14</b>
<b>SQ</b>	Udhëzuesi i përdorimit / Udhëzime rreth montimit	<b>15</b>
<b>AR</b>	دليل الاستخدام / تعليمات التجميع	<b>15</b>
<b>TR</b>	Kullanım kılavuzu / Montaj kılavuzu	<b>16</b>
<b>HU</b>	Használati útmutató / Szerelési útmutató	<b>17</b>

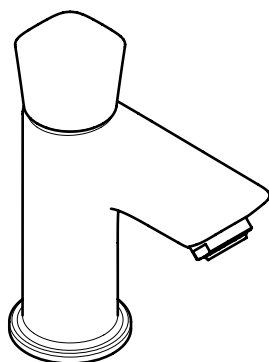

**Pillar Tap Logis 70 KF**  
71134000



## Sicherheitshinweise

- Bei der Montage müssen zur Vermeidung von Quetsch- und Schnittverletzungen Handschuhe getragen werden.
- Das Produkt darf nur zu Bade-, Hygiene- und Körperreinigungszwecken eingesetzt werden.

## Montagehinweise

- Vor der Montage muss das Produkt auf Transportschäden untersucht werden. Nach dem Einbau werden keine Transport- oder Oberflächenschäden anerkannt.
- Die Leitungen und die Armatur müssen nach den gültigen Normen montiert, gespült und geprüft werden.
- Die in den Ländern jeweils gültigen Installationsrichtlinien sind einzuhalten.

## Technische Daten

Betriebsdruck:	max. 1 MPa
Empfohlener Betriebsdruck:	0,1 - 0,5 MPa
Prüfdruck:	1,6 MPa (1 MPa = 10 bar = 147 PSI)

Das Produkt ist ausschließlich für Trinkwasser konzipiert!

## Symbolerklärung



Kein essigsäurehaltiges Silikon verwenden!



**Maße** (siehe Seite 20)



**Durchflussdiagramm** (siehe Seite 20)



**Serviceteile** (siehe Seite 21)



**Reinigung** (siehe Seite 22)



**Bedienung** (siehe Seite 19)



**Prüfzeichen** (siehe Seite 24)



## Consignes de sécurité

- Lors du montage, porter des gants de protection pour éviter toute blessure par écrasement ou coupure.
- Le produit ne doit servir qu'à se laver et à assurer l'hygiène corporelle.

## Instructions pour le montage

- Avant son montage, s'assurer que le produit n'a subi aucun dommage pendant le transport. Après le montage, tout dommage de transport ou de surface ne pourra pas être reconnu.
- Les conduites et la robinetterie doivent être montés, rincés et contrôlés selon les normes en vigueur.
- Les directives d'installation en vigueur dans le pays concerné doivent être respectées.

## Informations techniques

Pression de service autorisée:	max. 1 MPa
Pression de service conseillée:	0,1 - 0,5 MPa
Pression maximum de contrôle:	1,6 MPa (1 MPa = 10 bar = 147 PSI)

Le produit est exclusivement conçu pour de l'eau potable!

## Description du symbole



Ne pas utiliser de silicone contenant de l'acide acétique!



**Dimensions** (voir pages 20)



**Diagramme du débit** (voir pages 20)



**Pièces détachées** (voir pages 21)



**Nettoyage** (voir pages 22)



**Instructions de service**

(voir pages 19)



**Classification acoustique et débit**

(voir pages 24)





## Safety Notes

- △ Gloves should be worn during installation to prevent crushing and cutting injuries.
- △ The product may only be used for bathing, hygienic and body cleaning purposes.

## Installation Instructions

- Prior to installation, inspect the product for transport damages. After it has been installed, no transport or surface damage will be honoured.
- The pipes and the fixture must be installed, flushed and tested as per the applicable standards.
- The plumbing codes applicable in the respective countries must be observed.

## Technical Data

Operating pressure:	max. 1 MPa
Recommended operating pressure:	0,1 - 0,5 MPa
Test pressure:	1,6 MPa
	(1 MPa = 10 bar = 147 PSI)

The product is exclusively designed for drinking water!

## Symbol description

 Do not use silicone containing acetic acid!

 **Dimensions** (see page 20)

 **Flow diagram** (see page 20)

 **Spare parts** (see page 21)

 **Cleaning** (see page 22)

 **Operation** (see page 19)

 **Test certificate** (see page 24)

## Indicazioni sulla sicurezza

- △ Durante il montaggio, per evitare ferite da schiacciamento e da taglio bisogna indossare guanti protettivi.
- △ Il prodotto deve essere utilizzato esclusivamente per fare il bagno e per l'igiene del corpo.

## Istruzioni per il montaggio

- Prima del montaggio è necessario controllare che non ci siano stati danni durante il trasporto. Una volta eseguito il montaggio, non verranno riconosciuti eventuali danni di trasporto o delle superfici.
- Montare, lavare e controllare tubature e rubinetteria rispettando le norme correnti.
- Vanno rispettate le direttive di installazione nazionali vigenti nel rispettivo paese.

## Dati tecnici

Pressione d'uso:	max. 1 MPa
Pressione d'uso consigliata:	0,1 - 0,5 MPa
Pressione di prova:	1,6 MPa
	(1 MPa = 10 bar = 147 PSI)

Il prodotto è concepito esclusivamente per acqua potabile!

## Descrizione simbolo

 Non utilizzare silicone contenente acido acetico!

 **Ingombri** (vedi pagg. 20)

 **Diagramma flusso** (vedi pagg. 20)

 **Parti di ricambio** (vedi pagg. 21)

 **Pulitura** (vedi pagg. 22)

 **Procedura** (vedi pagg. 19)

 **Segno di verifica** (vedi pagg. 24)



## Indicaciones de seguridad

- △ Durante el montaje deben utilizarse guantes para evitar heridas por aplastamiento o corte.
- △ El producto solo debe ser utilizado para fines de baño, higiene y limpieza corporal.

## Indicaciones para el montaje

- Antes del montaje se debe examinar el producto contra daños de transporte. Después de la instalación no se reconoce ningún daño de transporte o de superficie.
- Los conductos y la grifería deben montarse, lavarse y comprobarse según las normas vigentes.
- Es obligatorio el cumplimiento de las directrices de instalación vigentes en el país respectivo.

## Datos técnicos

Presión en servicio: max. 1 MPa  
 Presión recomendada en servicio: 0,1 - 0,5 MPa  
 Presión de prueba: 1,6 MPa  
 (1 MPa = 10 bar = 147 PSI)

El producto ha sido concebido exclusivamente para agua potable.

## Descripción de símbolos



No utilizar silicona que contiene ácido acético!



**Dimensiones** (ver página 20)



**Diagrama de circulación**  
(ver página 20)



**Repuestos** (ver página 21)



**Limpiar** (ver página 22)



**Manejo** (ver página 19)



**Marca de verificación**  
(ver página 24)



## Veiligheidsinstructies

- △ Bij de montage moeten ter voorkoming van knel- en snijwonden handschoenen worden gedragen.
- △ Het product mag alleen voor het wassen, hygiënische doeleinden en voor de lichaamsreiniging worden gebruikt.

## Montage-instructies

- Vóór de montage moet het product gecontroleerd worden op transportschade. Na de inbouw wordt geen transport- of oppervlakteschade meer aanvaard.
- De leidingen en armaturen moeten gemonteerd, gespoeld en gecontroleerd worden volgens de geldige normen.
- De in de overeenkomstige landen geldende installatierichtlijnen moeten nageleefd worden.

## Technische gegevens

Werkdruk: max. 1 MPa  
 Aanbevolen werkdruk: 0,1 - 0,5 MPa  
 Getest bij: 1,6 MPa  
 (1 MPa = 10 bar = 147 PSI)

Het product is uitsluitend ontworpen voor drinkwater!

## Symboolbeschrijving



Gebruik geen zuurhoudende silicone!



**Maten** (zie blz. 20)



**Doorstroombiagram** (zie blz. 20)



**Service onderdelen** (zie blz. 21)



**Reinigen** (zie blz. 22)



**Bediening** (zie blz. 19)



**Keurmerk** (zie blz. 24)



## Sikkerhedsanvisninger

- △ Ved monteringen skal der bruges handsker for at undgå kvæstelser og snitsår.
- △ Produktet må kun bruges til bade-, hygiejne og kropssrengøringsformål.

## Monteringsanvisninger

- Før monteringen skal produktet kontrolleres for transportskader. Efter monteringen godkendes transportskader eller skader på overfladen ikke længere.
- Ledningerne og armaturerne skal monteres, skylles og kontrolleres iht. de gældende standarder.
- Installationsbestemmelserne, der gælder i det enkelte land, skal overholdes.

## Tekniske data

Driftstryk:	max. 1 MPa
Anbefalet driftstryk:	0,1 - 0,5 MPa
Prøvetryk:	1,6 MPa

(1 MPa = 10 bar = 147 PSI)

Produktet er udelukkende beregnet til drikkevand!

## Symbolbeskrivelse



Der må ikke benyttes eddikesyreholdig silikone!



**Målene** (se s. 20)



**Gennemstrømningsdiagram**

(se s. 20)



**Reservedele** (se s. 21)



**Rengøring** (se s. 22)



**Brugsanvisning** (se s. 19)



**Godkendelse** (se s. 24)

## Avisos de segurança

- △ Durante a montagem devem ser utilizadas luvas de protecção, de modo a evitar ferimentos resultantes de entalamentos e de cortes.
- △ O produto só pode ser utilizado para fins de higiene pessoal.

## Avisos de montagem

- Antes da montagem deve-se controlar o produto relativamente a danos de transporte. Após a montagem não são aceites quaisquer danos de transporte ou de superfície.
- As tubagens e a torneira têm que ser montadas, enxaguadas e verificadas de acordo com as normas em vigor.
- A prescrições de instalação válidas nos respetivos países devem ser respeitadas.

## Dados Técnicos

Pressão de funcionamento: max. 1 MPa

Pressão de func. recomendada: 0,1 - 0,5 MPa

Pressão testada: 1,6 MPa

(1 MPa = 10 bar = 147 PSI)

Este produto foi única e exclusivamente concebido para água potável!

## Descrição do símbolo



Não utilizar silicone que contenha ácido acético!



**Medidas** (ver página 20)



**Fluxograma** (ver página 20)



**Peças de substituição**

(ver página 21)



**Limpeza** (ver página 22)



**Funcionamento** (ver página 19)



**Marca de controlo** (ver página 24)

## Montering

(se s. 18) 

## Montagem

(ver página 18) 



## Wskazówki bezpieczeństwa

- △ Aby uniknąć zranień na skutek zgniecenia lub przecięcia, podczas montażu należy nosić rękawice ochronne.
- △ Produkt może być używany tylko do kąpieli, higieny i czyszczenia ciała.

## Wskazówki montażowe

- Przed montażem należy skontrolować produkt pod kątem szkód transportowych. Po montażu nie widać żadnych szkód transportowych ani szkód na powierzchni.
- Przewody i armatura muszą być montowane, płukane i kontrolowane według obowiązujących norm.
- Należy przestrzegać wytycznych instalacyjnych obowiązujących w danym kraju.

## Dane techniczne

Ciśnienie robocze: maks. 1 MPa  
 Zalecane ciśnienie robocze: 0,1 - 0,5 MPa  
 Ciśnienie próbne: 1,6 MPa  
 (1 MPa = 10 bary = 147 PSI)

Produkt przeznaczony wyłącznie do wody pitnej!

## Opis symbolu



Nie stosować silikonów zawierających kwas octowy!



**Wymiary** (patrz strona 20)



**Schemat przepływu**  
(patrz strona 20)



**Części serwisowe** (patrz strona 21)



**Czyszczenie** (patrz strona 22)



**Obsługa** (patrz strona 19)



**Znak jakości** (patrz strona 24)



## Bezpečnostní pokyny

- △ Pro zabránění řezným zraněním a pohmožděním je nutné při montáži nosit rukavice.
- △ Produkt smí být používán pouze ke koupání a za účelem tělesné hygieny.

## Pokyny k montáži

- Před montáží je třeba produkt zkontrolovat, zda nebyl při transportu poškozen. Po zabudování nebudou uznány žádné škody způsobené transportem nebo poškození povrchu.
- Vedení a armatura musí být namontovány, propláchnuty a otestovány podle platných norem.
- Je třeba dodržovat montážní pravidla platné v dané zemi.

## Technické údaje

Provozní tlak: max. 1 MPa  
 Doporučený provozní tlak: 0,1 - 0,5 MPa  
 Zkušební tlak: 1,6 MPa  
 (1 MPa = 10 bar = 147 PSI)

Výrobky Hansgrohe jsou vhodné pro přímý kontakt s pitnou vodou.

## Popis symbolů



Nepoužívat silikon s obsahem kyseliny octové!



**Rozměry** (viz strana 20)



**Diagram průtoku** (viz strana 20)



**Servisní díly** (viz strana 21)



**Čištění** (viz strana 22)



**Ovládání** (viz strana 19)



**Zkušební značka** (viz strana 24)



## **Bezpečnostné pokyny**

- △ Pri montáži musíte nosiť rukavice, aby ste predišli pomliaždeninám a rezným poraneniam.
- △ Produkt sa smie používať len na kúpanie a telesnú hygienu.

## **Pokyny pre montáž**

- Pred montážou musíte produkt skontrolovať, či nebol počas transportu poškodený. Po zabudovaní nebudú uznané žiadne škody spôsobené transportom alebo poškodenia povrchu.
- Potrubia a vybavenie musia byť namontované, prepláchnuté a vybavené v platnom normami.
- Je potrebné dodržiavať smernice o inštalácii, ktoré sú práve teraz platné v krajinách.

## **Technické údaje**

Prevádzkový tlak:	max. 1 MPa
Doporučený prevádzkový tlak:	0,1 - 0,5 MPa
Skúšobný tlak:	1,6 MPa

(1 MPa = 10 bar = 147 PSI)

Výrobok je koncipovaný výhradne pre pitnú vodu!

## **Popis symbolov**

 Nepoužívať silikón s obsahom kyseliny octovej!

 **Rozmery** (vid' strana 20)

 **Diagram prietoku** (vid' strana 20)

 **Servisné diely** (vid' strana 21)

 **Čistenie** (vid' strana 22)

 **Obsluha** (vid' strana 19)

 **Osvedčenie o skúške** (vid' strana 24)

## **安全技巧**

- △ 装配时为避免挤压和切割受伤，必须戴上手套。
- △ 本产品只允许作为洗浴、卫生和洁身之用。

## **安装提示**

- 安装前必须检查产品是否受到运输损害。安装后将不认可运输损害或表面损伤。
- 管道和阀门必须根据通用标准进行安装、冲洗和检查。
- 请遵守当地国家现行的安装规定。

## **技术参数**

工作压力:	最大 1 MPa
推荐工作压力:	0,1 - 0,5 MPa
测试压强:	1,6 MPa

(1 MPa = 10 bar = 147 PSI)

该产品专为饮用水设计！

## **符号说明**

 请勿使用含有乙酸的硅胶！

 **大小** (参见第页 20)

 **流量示意图** (参见第页 20)

 **备用零件** (参见第页 21)

 **清洗** (参见第页 22)

 **操作** (参见第页 19)

 **检验标记** (参见第页 24)



## Указания по технике безопасности

- Во время монтажа следует надеть перчатки во избежание прищемления и порезов.
- Изделие разрешается использовать только в гигиенических целях: для принятия ванны и личной гигиены.

## Указания по монтажу

- Перед монтажом следует проверить изделие на предмет повреждений при перевозке. После монтажа претензии о возмещении ущерба за повреждения при перевозке или повреждения поверхностей не принимаются.
- Трубы и арматура должны быть установлены, промыты и проверены в соответствии с действующими нормами.
- Необходимо соблюдать требования по монтажу, действующие в соответствующих странах.

## Технические данные

Рабочее давление: не более 1 МПа  
 Рекомендуемое рабочее давление: 0,1 - 0,5 МПа  
 Давления: 1,6 МПа  
 (1 МПа = 10 bar = 147 PSI)

Изделие предназначено исключительно для питьевой воды!

## Описание символов



Не применяйте силикон, содержащий уксусную кислоту.



**Размеры** (см. стр. 20)



**Схема потока** (см. стр. 20)



**Комплект** (см. стр. 21)



**Очистка** (см. стр. 22)



**Эксплуатация** (см. стр. 19)



**Знак технического контроля**  
(см. стр. 24)



## Turvallisuusohjeet

- Asennuksessa on käytettävä käsineitä puristumien ja viiltojen aiheuttamien tapaturmien estämiseksi.
- Tuotetta saa käyttää ainoastaan kylpy-, hygienia- ja puhdistustarkoituksiin.

## Asennusohjeet

- Ennen asennusta on tarkastettava tuotteen mahdolliset kuljetusvahingot. Asennuksen jälkeen kuljetus- ja pintavaurioita ei hyväksytä.
- Putket ja hana on asennettava, huuhdeltava ja tarkastettava voimassa olevien standardien mukaisesti.
- Jokaisessa maassa on noudatettava siellä päteviä asennusohjeita.

## Tekniset tiedot

Käyttöpaine: maks. 1 МПа  
 Suositeltu käyttöpaine: 0,1 - 0,5 МПа  
 Koestuspaine: 1,6 МПа  
 (1 МПа = 10 bar = 147 PSI)

Tuote on suunniteltu käytettäväksi ainoastaan juomaveden kanssa!

## Merkin kuvaus



Älä käytä etikkahappopitoista silikonia!



**Mitat** (katso sivu 20)



**Virtausdiagrammi** (katso sivu 20)



**Varaosat** (katso sivu 21)



**Puhdistus** (katso sivu 22)



**Käyttö** (katso sivu 19)



**Koestusmerkki** (katso sivu 24)





## Säkerhetsanvisningar

- △ Handskar ska bäras under monteringsarbetet så att man kan undvika kläm- och skärskador.
- △ Produkten får bara användas till kroppshygien med bad och dusch.

## Monteringsanvisningar







- Det måste undersökas om produkten har transportskador innan den monteras. Efter monteringen accepteras inga transport- eller ytskiktsskador.
- Ledningarna och blandaren måste monteras, spolas igenom och kontrolleras enligt de gällande normerna.
- De installationsriktlinjer som gäller i länderna ska följas.

## Tekniska data

Driftstryck:	max. 1 MPa
Rek. driftstryck:	0,1 - 0,5 MPa
Tryck vid provtryckning:	1,6 MPa
	(1 MPa = 10 bar = 147 PSI)

Produkten är enbart avsedd för dricksvatten!

## Symbolförklaring

-  Använd inte silikon som innehåller ättiksyra!
-  **Måtten** (se sidan 20)
-  **Flödesschema** (se sidan 20)
-  **Reservdelar** (se sidan 21)
-  **Rengöring** (se sidan 22)
-  **Hantering** (se sidan 19)
-  **Testsigill** (se sidan 24)

## Saugumo technikos nurodymai

- △ Apsaugai nuo užspaudimo ir įsijpavimo montavimo metu mūvėkite pirštines.
- △ Gaminys turi būti naudojamas tik maudymuisi, kūno higienai ir švarai palaikyti.

## Montavimo instrukcija







- Prieš montuojant būtina patikrinti, ar gaminys nebuvo pažeistas transportavimo metu. Sumontavus pretenzijos dėl transportavimo ir paviršiaus pažeidimų nepriimamos.
- Vamzdžiai ir sujungimai turi būti montuojami, plaunami ir tikrinami pagal galiojančias normas.
- Laikykites atitinkamoje šalyje galiojančių direktyvų dėl įrengimo.

## Techniniai duomenys

Darbinis slėgis:	ne daugiau kaip 1 MPa
Rekomenduojamas slėgis:	0,1 - 0,5 MPa
Bandomasis slėgis:	1,6 MPa
	(1 MPa = 10 barų = 147 PSI)

Produktas skirtas tik geriamajam vandeniui!

## Simbolio aprašymas

-  Nenaudokite silikono, kurio sudėtyje yra acto rūgšties!
-  **Išmatavimai** (žr. psl. 20)
-  **Pralaidumo diagrama** (žr. psl. 20)
-  **Atsarginės dalys** (žr. psl. 21)
-  **Valymas** (žr. psl. 22)
-  **Eksplotacija** (žr. psl. 19)
-  **Bandomo pažyma** (žr. psl. 24)

## Montering

(se sidan 18)



## Montavimas

(žr. psl. 18)



**Sigurnosne upute**

- ⚠ Prilikom montaže se radi sprječavanja prignječenja i posjekotina moraju nositi rukavice.
- ⚠ Proizvod se smije primjenjivati samo za kupanje, tuširanje i osobnu higijenu.

**Upute za montažu**

- Prije montaže mora se provjeriti je li proizvod oštećen prilikom transporta. Nakon ugradnje se ne priznaju nikakve reklamacije koje se odnose na površinska i transportna oštećenja.
- Cijevi i armatura moraju biti postavljeni, isprani i testirani prema važećim normama.
- Obvezno se moraju uvažiti propisi o instalacijama koji vrijede u dotičnoj zemlji.

**Tehnički podatci**

Najveći dopušteni tlak:	tlak 1 MPa
Preporučeni tlak:	0,1 - 0,5 MPa
Probni tlak:	1,6 MPa
	(1 MPa = 10 bar = 147 PSI)

Proizvod je koncipiran isključivo za pitku vodu!

**Opis simbola**

Nemojte koristiti silikon koji sadrži octenu kiselinu!



**Mjere** (pogledaj stranicu 20)



**Dijagram protoka**  
(pogledaj stranicu 20)



**Rezervni djelovi**  
(pogledaj stranicu 21)



**Čišćenje** (pogledaj stranicu 22)



**Upotreba** (pogledaj stranicu 19)



**Oznaka testiranja**  
(pogledaj stranicu 24)

**Instrucțiuni de siguranță**

- ⚠ La montare utilizați mănuși pentru evitarea contuziunilor și tăierii mâinilor.
- ⚠ Produsul poate fi utilizat doar pentru spălarea, menținerea igienei și curățarea corpului.

**Instrucțiuni de montare**

- Înainte de instalare verificați, dacă produsul prezintă deteriorări de transport. După instalare garanția nu acoperă deteriorările de transport și cele de suprafață.
- Conductele și bateriile trebuie montate, spălate și verificate conform normelor în vigoare.
- Respectați reglementările referitoare la instalare valabile în țara respectivă.

**Date tehnice**

Presiune de funcționare:	max. 1 MPa
Presiune de funcționare recomandată:	0,1 - 0,5 MPa
Presiune de verificare:	1,6 MPa
	(1 MPa = 10 bar = 147 PSI)

Produsul este destinat exclusiv pentru apă potabilă.

**Descrierea simbolurilor**

Nu utilizați silicon cu conținut de acid acetic!



**Dimensiuni** (vezi pag. 20)



**Diagrama de debit** (vezi pag. 20)



**Piese de schimb** (vezi pag. 21)



**Curățare** (vezi pag. 22)



**Utilizare** (vezi pag. 19)



**Certificat de testare** (vezi pag. 24)

**Sastavljanje**

10 (pogledaj stranicu 18)

**Montare**

(vezi pag. 18)

**⚠ Υποδειξεις ασφαλείας**

- ⚠ Για να αποφύγετε τραυματισμούς κατά τη συναρμολόγηση πρέπει να φοράτε γάντια.
- ⚠ Το προϊόν επιτρέπεται να χρησιμοποιείται μόνο σαν μέσο λουτρού, υγιεινής και καθαρισμού του σώματος.

**Οδηγίες συναρμολόγησης**

- Πριν τη συναρμολόγηση πρέπει να εξεταστεί το προϊόν για ζημιές μεταφοράς. Μετά την εγκατάσταση δεν αναγνωρίζονται ζημιές από τη μεταφορά ή επιφανειακές ζημιές.
- Οι σΩλήνες και η μπαταρία πρέπει να τοποθετηθούν σύμφωνα με τα ισχύοντα πρότυπα, να τεθούν υπό πίεση και να δοκιμαστούν.
- Θα πρέπει να τηρούνται οι οδηγίες εγκατάστασης που ισχύουν σε κάθε κράτος.

**Τεχνικά Χαρακτηριστικά**

Λειτουργία πίεσης:	έως 1 MPa
Συνιστώμενη λειτουργία πίεσης:	0,1 - 0,5 MPa
Πίεση ελέγχου:	1,6 MPa (1 MPa = 10 bar = 147 PSI)

Το προϊόν έχει σχεδιαστεί αποκλειστικά για πόσιμο νερό!

**Περιγραφή συμβόλων**

Μην χρησιμοποιείτε σιλικόνη που περιέχει οξικό οξύ!



**Διαστάσεις** (βλ. Σελίδα 20)



**Διάγραμμα ροής** (βλ. Σελίδα 20)



**Ανταλλακτικά** (βλ. Σελίδα 21)



**Καθαρισμός** (βλ. Σελίδα 22)



**Χειρισμός** (βλ. Σελίδα 19)



**Σήμα ελέγχου** (βλ. Σελίδα 24)

**⚠ Varnostna opozorila**

- ⚠ Pri montaži je treba nositi rokavice, da se preprečijo poškodbe zaradi zmečkanja ali urezov.
- ⚠ Ta izdelek se sme uporabljati le z namenom umivanja, vzdrževanja higiene in telesne nege.

**Navodila za montažo**

- Pred montažo je treba izdelek preveriti glede morebitnih transportnih poškodb. Po vgradnji transportne ali površinske poškodbe ne bodo več priznane.
- Cevi in armaturo je treba montirati, izprati in preveriti po veljavnih standardih.
- Upoštevati je treba pravilnike o inštalacijah, ki veljajo v posamezni državi.

**Tehnični podatki**

Delovni tlak:	maks. 1 MPa
Priporočeni delovni tlak:	0,1 - 0,5 MPa
Preskusni tlak:	1,6 MPa (1 MPa = 10 bar = 147 PSI)

Proizvod je zasnovan izključno za sanitarno vodo!

**Opis simbola**

Ne smete uporabiti silikona, ki vsebuje ocetno kislino!



**Mere** (glejte stran 20)



**Diagram pretoka** (glejte stran 20)



**Rezervni deli** (glejte stran 21)



**Čiščenje** (glejte stran 22)



**Upravljanje** (glejte stran 19)



**Preskusni znak** (glejte stran 24)





## Ohutusjuhised

- △ Kandke paigaldamisel muljumis- ja löikevigastuste vältimiseks kindaid.
- △ Toodet tohib kasutada ainult pesemis-, hügieeni- ja kehahügieeniseesmärkidel.

## Paigaldamisjuhised

- Enne paigaldamist tuleb toodet kontrollida transpordikahjustuste osas. Pärast paigaldamist ei tunnustata enam transpordi- või pinnakahjustuste kaebuseid.
- Voolikute ja segisti paigaldamisel, loputamisel ja kontrollimisel tuleb lähtuda kehtivatest normatiividest.
- Vastavas riigis kehtivaid paigalduseeskirju tuleb järgida.

## Tehnilised andmed

Töörõhk	maks. 1 MPa
Soovitav töörõhk:	0,1 - 0,5 MPa
Kontrollsurve:	1,6 MPa

(1 MPa = 10 baari = 147 PSI)

Toode on ette nähtud eranditult joogivee jaoks!

## Sümbolite kirjeldus



Ärge kasutage äädikhapet sisaldavat silikooni!



**Mõõtude** (vt lk 20)



**Läbivooludiagramm** (vt lk 20)



**Varuosad** (vt lk 21)



**Puhastamine** (vt lk 22)



**Kasutamine** (vt lk 19)



**Kontrollsertifikaat** (vt lk 24)



## Drošības norādes

- △ Montāžas laikā, lai izvairītos no spiedumiem un iegriezumiem, nepieciešams nēsāt cimdus.
- △ Šo produktu drīkst izmantot tikai, lai mazgātos, higiēnai un ķermeņa tīrīšanai.

## Norādījumi montāžai

- Pirms montāžas nepieciešams pārbaudīt, vai produktam transportēšanas laikā nav radušies bojājumi. Pēc iebūvēšanas bojājumi, kas radušies transportēšanas laikā, vai virsmas bojājumi netiek atzīti.
- Caurļvadi un armatūra ir jāuzstāda, jāizskalo un jāpārbauda saskaņā ar spēkā esošajiem standartiem.
- Jāievēro attiecīgās valstīs spēkā esošās montāžas prasības.

## Tehniskie dati

Darba spiediens:	maks. 1 MPa
Ieteicamais darba spiediens:	0,1 - 0,5 MPa
Pārbaudes spiediens:	1,6 MPa

(1 MPa = 10 bar = 147 PSI)

Izstrādājums ir paredzēts tikai dzeramajam ūdenim!

## Simbolu nozīme



Neizmantojot silikonu, kas satur etiķskābi!



**Izmērus** (skat. lpp. 20)



**Caurplūdes diagramma**

(skat. lpp. 20)



**Rezerves daļas** (skat. lpp. 21)



**Tīrīšana** (skat. lpp. 22)



**Lietošana** (skat. lpp. 19)



**Pārbaudes zīme** (skat. lpp. 24)

## Paigaldamine

(vt lk 18)

## Montāža

(skat. lpp. 18)



## Sigurnosne napomene

- △ Prilikom montaže se radi sprečavanja prignječenja i posekotina moraju nositi rukavice.
- △ Proizvod sme da se koristi samo za kupanje, tuširanje i ličnu higijenu.

## Instrukcije za montažu

- Pre montaže se mora proveriti da li je proizvod oštećen pri transportu. Nakon ugradnje se ne priznaju nikakve reklamacije koje se odnose na površinska i transportna oštećenja.
- Vodovi i armatura moraju biti postavljeni, isprani i testirani prema važećim normama.
- Treba se pridržavati propisa koji u određenim zemljama važe za instalacije.

## Tehnički podaci

Radni pritisak:	maks. 1 MPa
Preporučeni radni pritisak:	0,1 - 0,5 MPa
Probni pritisak:	1,6 MPa
	(1 MPa = 10 bar = 147 PSI)

Proizvod je koncipiran isključivo za pijaću vodu!

## Opis simbola



Nemojte koristiti silikon koji sadrži sircetnu kiselinu!



**Mere** (vidi stranu 20)



**Dijagram protoka** (vidi stranu 20)



**Rezervni delovi** (vidi stranu 21)



**Čišćenje** (vidi stranu 22)



**Rukovanje** (vidi stranu 19)



**Ispitni znak** (vidi stranu 24)

## Sikkerhetshenvisninger

- △ Bruk hansker under montasjen for å unngå klem- og kuttskader.
- △ Produktet skal kun brukes for bade-, hygiene- og kroppshygiene.

## Montagehenvisninger

- Før montasjen skal produktet sjekkes for transportskader. Etter monteringen aksepteres ikke noen transport- eller overflateskader.
- Ledningene og armaturen skal monteres, spyles og sjekkes iht. de gyldige normer.
- Gjeldende retningslinjer for rørleggerarbeid i de enkelte land skal følges.

## Tekniske data

Driftstrykk	maks. 1 MPa
Anbefalt driftstrykk:	0,1 - 0,5 MPa
Prøvetrykk	1,6 MPa
	(1 MPa = 10 bar = 147 PSI)

Produktet er utelukkende designet for drikkevann!

## Symbolbeskrivelse



Ikke bruk silikon som inneholder eddiksyre!



**Mål** (se side 20)



**Gjennomstrømningsdiagram**  
(se side 20)



**Serviceleder** (se side 21)



**Rengjøring** (se side 22)



**Betjening** (se side 19)



**Prøveemerke** (se side 24)

## Montaža

(vidi stranu 18)



## Montasje

(se side 18)





## Указания за безопасност

- △ При монтажа трябва да се носят ръкавици, за да се избегнат наранявания поради притискане или порязване.
- △ Позволено е използването на продукта само за къпане, хигиена и цели на почистване на тялото.

## Указания за монтаж

- Преди монтажа продуктът трябва да се провери за транспортни щети. След монтажа не се признават транспортни или повърхностни щети.
- Тръбопроводите и арматурата трябва да се монтират, промият и проверят в съответствие с валидните норми.
- Трябва да бъдат спазвани валидните в съответните страни предписания за инсталиране.

## Технически данни

Работно налягане: макс. 1 МПа  
 Препоръчително работно налягане: 0,1 - 0,5 МПа  
 Контролно налягане: 1,6 МПа  
 (1 МПа = 10 bar = 147 PSI)

Продуктът е разработен само за питейна вода!

## Описание на символите



Не използвайте силикон, съдържащ оцетна киселина!



**Размери** (вижте стр. 20)



**Диаграма на потока**  
(вижте стр. 20)



**Сервизни части** (вижте стр. 21)



**Почистване** (вижте стр. 22)



**Обслужване** (вижте стр. 19)



**Контролен знак** (вижте стр. 24)



## 安全上の注意

- △ 施工の際は手を挟んだり怪我をしないように、手袋をはめてください。
- △ この製品は、体や手を洗う等の製品本来の目的以外には使用しないでください。

## 施工上の注意

- 製品の施工前に輸送でのダメージがないか確認してください。施工後のキズ等のお申し出はお断りさせていただきます。
- 配管と水栓は、関連法規に従って施工、洗浄、および試験を行ってください。
- 施工行う地域に適用される関連法規をお守りください。

## 技術資料

使用圧力: 最大 1 МПа  
 推奨使用水圧: 0,1 - 0,5 МПа  
 耐圧試験圧力: 1,6 МПа  
 (1 МПа = 10 bar = 147 PSI)

この製品は飲料水での使用が前提となっています (日本においては水道法に適合する飲料水) !

## アイコンの説明



酢酸系シリコンをご使用にならないでください!



**寸法** (次のページを参照 20)



**流量曲線図** (次のページを参照 20)



**スペアパーツ** (次のページを参照 21)



**お手入れ方法** (次のページを参照 22)



**使用方法** (次のページを参照 19)



**認証について** (次のページを参照 24)

## Монтаж

(вижте стр. 18) 

## 施工方法

(次のページを参照 18) 

**⚠ Udhëzime sigurie**

- ⚠ Për të evituar lëndimet e pickimeve ose të prerjeve gjatë procesit të montimit duhet që të vishni doreza.
- ⚠ Produkti duhet të përdoret vetëm qëllimet e banjave, të higjienës dhe të larjes së trupit.

**Udhëzime për montimin**

- Përpara montimit duhet që produkti të kontrollohet për dëmtime nga transporti. Pas instalimit nuk do të njihet asnjë dëmtim nga transporti ose dëmtim i sipërfaqes.
- Tubacionet dhe rubinetet duhet që të montohen, të shpëlahen dhe të kontrollohen sipas standardeve në fuqi
- Duhet të respektohen linjat udhëzuese të instalimit, të vlefshme për vendet respektive.

**Të dhëna teknike**

Presioni gjatë punës	maks. 1 MPa
Presioni i rekomanduar:	0,1 - 0,5 MPa
Presioni për provë:	1,6 MPa
	(1 MPa = 10 bar = 147 PSI)

Produkti është projektuar ekskluzivisht për ujë të pijshëm!

**Përshkrimi i simbolit**

 Mos përdorni silikon që në përbërje ka acid acetik.

 **Përmasat** (shih faqen 20)

 **Diagrami i qarkullimit**  
(shih faqen 20)

 **Pjesët e servisit** (shih faqen 21)

 **Pastrimi** (shih faqen 22)

 **Përdorimi** (shih faqen 19)

 **Shenja e kontrollit** (shih faqen 24)

**⚠ تنبيهات الأمان**

- ⚠ يجب ارتداء قفازات لليد أثناء التركيب لتجنب حدوث أخطار الإنحشار أو الجروح.
- ⚠ لا يجب استخدام المنتج إلا في أغراض الاستحمام والأغراض الصحية وأغراض تنظيف الجسم.

**تعليمات التركيب**

- قبل القيام بعملية التركيب، يجب فحص المنتج للتأكد من خلوه من أية تلفيات ناتجة عن النقل. بعد القيام بعملية التركيب، لن يتم الاعتراف بوجود أية تلفيات سطحية أو تلفيات ناتجة عن عملية النقل.
- يجب تركيب وغسيل واختبار التوصيلات وخلطات المياه طبقاً للمعايير السارية.
- يجب مراعاة القواعد الخاصة بالتركيب وأعمال السباكة وفقاً للوائح الخاصة بكل بلد.

**المواصفات الفنية**

الحد الأقصى 1 ميجاباسكال	ضغط التشغيل:
0,1 - 0,5 ميجاباسكال	ضغط التشغيل الموصى به:
1,6 ميجاباسكال	ضغط الاختبار:
(1 ميجاباسكال = 10 بار = 147 PSI)	المنتج مخصص فقط لماء الشرب!

**وصف الرمز**

 هام! لا تستخدم السليكون الذي يحتوي على أحماض!

 أبعاد (راجع صفحة 20)

 رسم للصرف (راجع صفحة 20)

 قطع الغيار (راجع صفحة 21)

 التنظيف (راجع صفحة 22)

 التشغيل (راجع صفحة 19)

 شهادة اختبار (راجع صفحة 24)

**Montimi**

(shih faqen 18) 

**التركيب**

(راجع صفحة 18) 



# Türkçe



## Güvenlik uyarıları

- △ Montaj esnasında ezilme ve kesilme gibi yaralanmaları önlemek için eldiven kullanılmalıdır.
- △ Ürün yalnızca banyo, hijyen ve beden temizliği amaçları doğrultusunda kullanılabilir.

## Montaj açıklamaları

- Montaj işleminden önce ürün nakliye hasarları yönünden kontrol edilmelidir. Montaj işleminden sonra nakliye veya yüzey hasarları için sorumluluk üstlenilmemektedir.
- Boruların ve armatürün montajı, yıkanması ve kontrolü geçerli normlara göre yapılmalıdır.
- Ülkelerde geçerli kurulum yönetmeliklerine riayet edilmelidir.

## Teknik bilgiler

İşletme basıncı: azami 1 MPa  
Tavsiye edilen işletme basıncı: 0,1 - 0,5 MPa  
Kontrol basıncı: 1,6 MPa  
(1 MPa = 10 bar = 147 PSI)

Ürün sadece şebeke suyu için tasarlanmıştır!

## Simge açıklaması



Asetik asit içeren silikon kullanmayın!



**Ölçüleri** (bakınız sayfa 20)



**Akış diyagramı** (bakınız sayfa 20)



**Yedek Parçalar** (bakınız sayfa 21)



**Temizleme** (bakınız sayfa 22)



**Kullanımı** (bakınız sayfa 19)



**Kontrol işareti** (bakınız sayfa 24)

## Garanti Belgesi

### Üretici veya İthalatçı Firmanın

Unvanı: Hansgrohe Armatür Ltd. Şti  
Adresi: Fulya Mahallesi Bahçeler Sokak Efe han 20/C  
Mecidiyeköy Şişli İstanbul  
Telefonu: (0-212) 273 07 30  
Faks: (0-212) 273 07 40  
web adresi: www.hansgrohe.com.tr

## Malın

Markası: Hansgrohe  
Cinsi: Sıhhi tesisat malzemesi  
Garanti Süresi: 2 YIL  
Azami Tamir Süresi: 20 İş günü

## Genel Müdür

Albert Emlek

Satıcı Firmanın:

Unvanı:  
Adresi:  
Telefonu:  
Faks:  
e-posta:  
Fatura Tarih ve Sayısı:  
Marka ve Modeli:  
Teslim Tarihi ve Yeri:  
Yetkilinin İmzası:  
Firmanın Kaşesi:  
Bu bölümü, ürünü aldığınız Yetkili Satıcı imzalayacak ve kaşeleyecektir.

## Montajı

(bakınız sayfa 18)





## Biztonsági utasítások

- △ A szerelésnél a zúzódások és vágási sérülések elkerülése érdekében kesztyűt kell viselni.
- △ A terméket csak fürdéshez, mosakodáshoz, és egészségügyi tisztálkodáshoz szabad használni.

## Szerelési utasítások

- A szerelés előtt ellenőrizni kell, hogy a terméknek nincs-e szállítási sérülése. Beépítés után a szállítási vagy felületi sérüléseket nem ismerik el.
- A vezetékeket és a csaptelepet az érvényes szabványoknak megfelelően kell felszerelni, öblíteni és ellenőrizni
- Az egyes országokban érvényes installációs irányelveket be kell tartani.

## Műszaki adatok

Üzemi nyomás:	max. 1 MPa
Ajánlott üzemi nyomás:	0,1 - 0,5 MPa
Nyomáspróba:	1,6 MPa
	(1 MPa = 10 bar = 147 PSI)

A terméket kizárólag ivóvízhez tervezték!

## Szimbólumok leírása

 Ne használjon ecetsavtartalmú szilikon!

 **Méretet** (lásd a oldalon 20)

 **Átfolyási diagram**  
(lásd a oldalon 20)

 **Tartozékok** (lásd a oldalon 21)

 **Tisztítás** (lásd a oldalon 22)

 **Használat** (lásd a oldalon 19)

- A csaptelepeken átfolyt víz hőmérséklete fogyasztásra szánt víz esetében a 65°C-ot nem haladhatja meg. A csaptelep nem eredményezheti az emberi fogyasztásra (pl. ivás és főzés céljából) szánt víz minőségsromlását.

- Beüzemelés és üzemszünetek után szigorúan be kell tartani a használati útmutatóban leírtakat. Beüzemeléskor a csaptelepet át kell öblíteni, legalább 2 percig történő hideg- és melegvízes folyamatot javasolunk. Minimum 1 napos üzemszünet után fogyasztás előtt a csaptelepben stagnáló hideg- illetve melegvíz fogyasztása nem javasolt, a csaptelepben stagnáló vizet ki kell engedni, legalább 2 perces folyamat javasolt. A kifolyatás során nyert vizet ivóvízként, illetve ételkészítési céllal felhasználni nem szabad.
- Tekintettel arra, hogy a forró víz fémoldó képessége a hideg víznél nagyobb, emiatt főzés ivás céljából az OKI a hideg víz használatát javasolja.
- A csaptelepek perlátorát javasolt havonta vízkőteleníteni, illetve fertőtleníteni. A csaptelepek tisztítása, fertőtlenítése során kizárólag olyan vegyszer alkalmazható, amely megfelel a 201/2001. (X.25) Kormányrendelet, illetve a 38/2003. (VII.7) ÉSZCsM-FVM-KvVM együttes rendeletben leírtaknak.
- A perlátor működési elvéből adódóan jelentős aeroszolt képez, így Legionella expozíció szempontjából fokozott kockázatot jelent. Ezért alkalmazása nem javasolt az egészségügyi intézmények fekvőbeteg ellátó szobáiban, illetve minden olyan helyen, ahol a hideg és / vagy használati melegvíz Legionella csíraszámá eléri a 49/2015 (XI.6.) EMMI rendelet alapján meghatározott beavatkozási szintet.

 **Vizsgajel** (lásd a oldalon 24)

## Szerelés

(lásd a oldalon 18) 

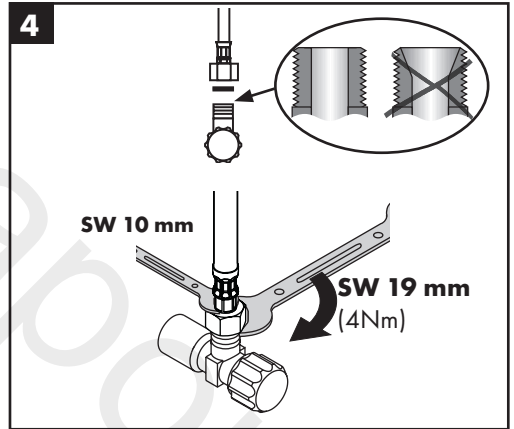
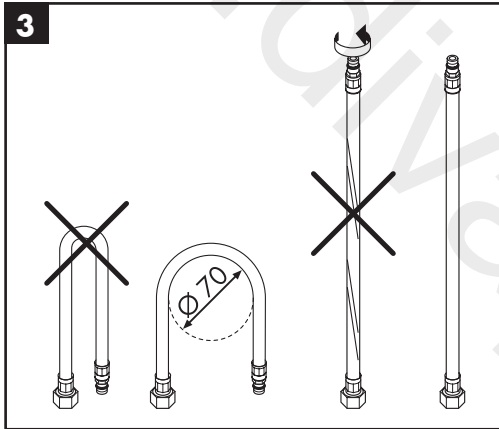
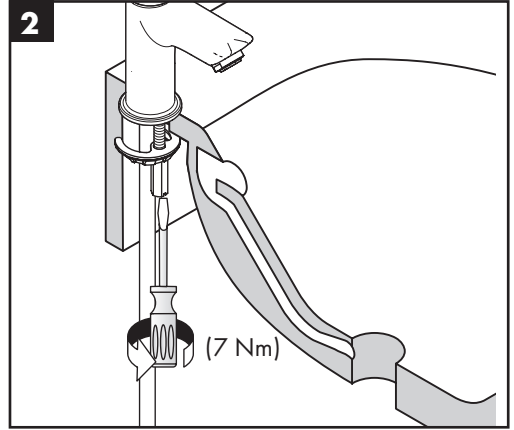
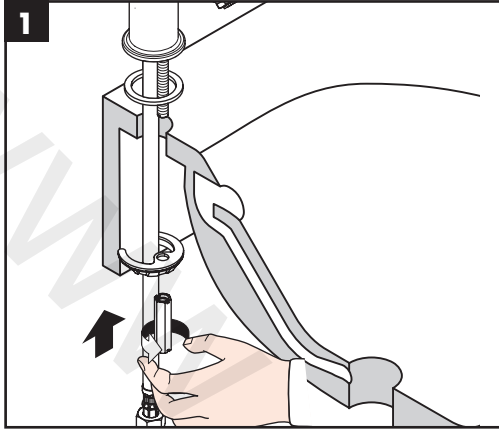

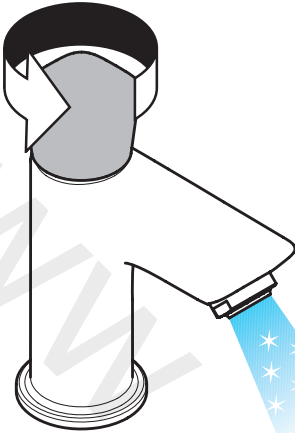

öffnen / ouvert / open / aperto / abierto / open /  
åbne / abrir / otworzyć / otevřít / otvorit / 开 /  
открыть / nyitás / avaaminen / öppna / atidaryti /  
Отваранје / açmak / deschide / ανοικτό / odpreti /  
avage / atvērt / otvoriti / åpne / отваряне / hare /  
فتح / 開く

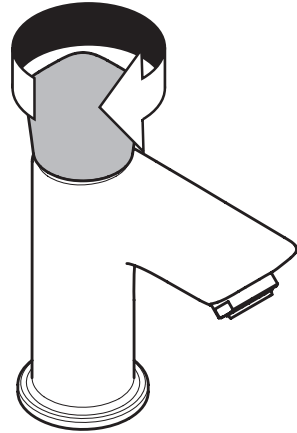

schließen / fermé / close / chiudere / cerrar / sluiten /  
lukke / fechar / zamknąć / zavřít / uzavrieť / 关 /  
закрывать / bezárás / sulkeminen / stänga / uždaryti /  
Zatvaranje / kapatmak / închide / κλειστό / zapreti /  
sulgege / aizvērt / zatvori / lukke / затваряне /  
mbylle / إغلاق / 閉じる



## Pillar Tap Logis 70 KF

71134000

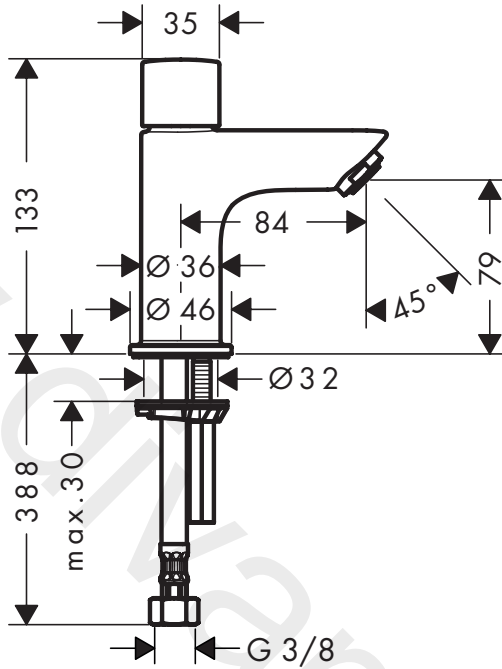

## Pillar Tap Logis 70 KF

71134000

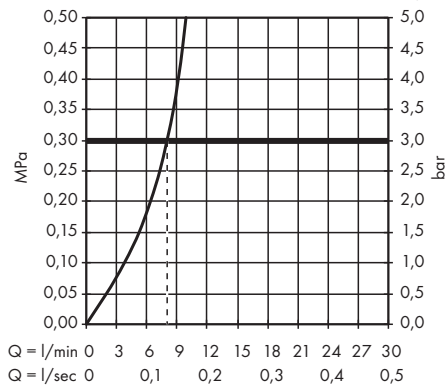

**Pillar Tap Logis 70 KF**  
71134000

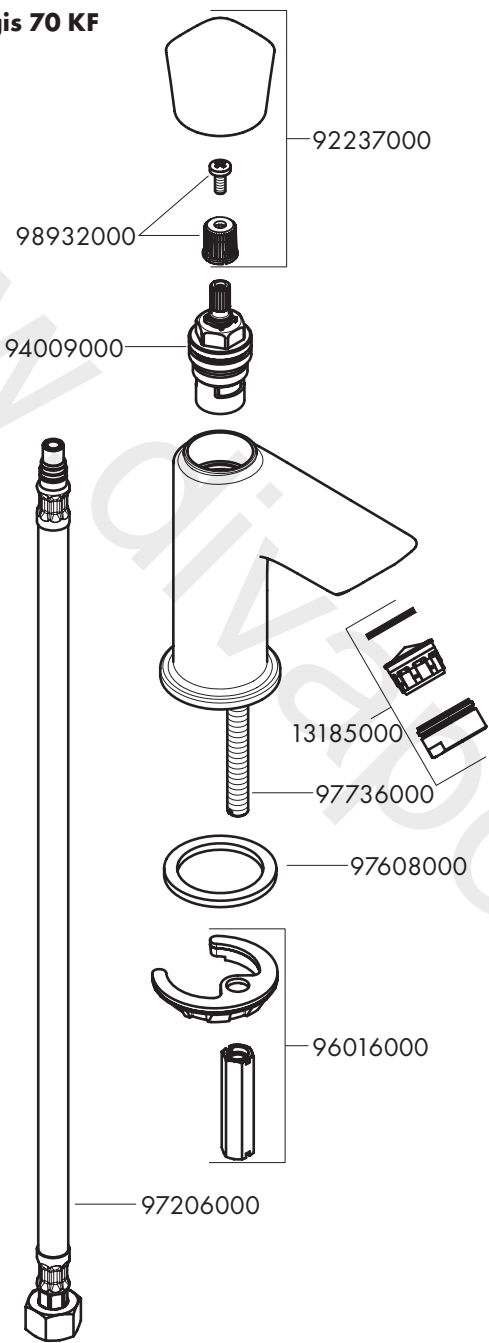



- DE** Reinigungsempfehlung / Garantie / Kontakt
- FR** Recommandation pour le nettoyage / Garanties / Contact
- EN** Cleaning recommendation / Warranty / Contact
- IT** Raccomandazione di pulizia / Garanzia / Contatto
- ES** Recomendaciones para la limpieza / Garantía / Contacto
- NL** Aanbevelingen inzake reiniging / Garantie / Contact
- DK** Rengøringsvejledning / Garanti / Kontakt
- PT** Recomendações de limpeza / Garantia / Contacto
- PL** Zalecenie dotyczące pielęgnacji / Gwarancja / Kontakt
- CS** Doporučení k čištění / Záruka / Kontakt
- SK** Odporúčania pre čistenie / Záruka / Kontakt
- ZH** 清洁指南 / 担保 / 接触
- RU** Рекомендации по очистке / Гарантия / Контакты
- FI** Puhdistussuositus / Takuu / Kosketus
- SV** Rengöringsrekommendationer / Garanti / Contacto
- LT** Valymo rekomendacijos / Garantija / Kontaktai
- HR** Preporuke za čišćenje / Garancija / Kontakt
- TR** Temizleme önerisi / Garanti / Temas
- RO** Recomandări pentru curățare / Garanție / Contact
- EL** Σύσταση καθαρισμού / Εγγύηση / επαφή
- SL** Priporočilo za čiščenje / Garancija / Kontakt
- ET** Puhastussuositused / Garantii / Kontakt
- LV** Tīrīšanas ieteikumi / Garantija / Kontakti
- SR** Preporuke za čišćenje / Garancija / Kontakt
- NO** Anbefaling for rengjøring / Garanti / Kontakt
- BG** Препоръка за почистване / Гаранция / Контакт
- SQ** Këshilla rreth pastrimit / Garancia / Kontakt
- KO** 세정시 권장사항 / 품질보증 / 접촉
- AR** توصيات التنظيف / الضمان / اتصال
- HU** Tisztítási tanácsok / Garancia / érintkezés
- JP** お手入れの方法 / 保証について / ご連絡先



[www.hansgrohe.com/  
cleaning-recommendation](http://www.hansgrohe.com/cleaning-recommendation)

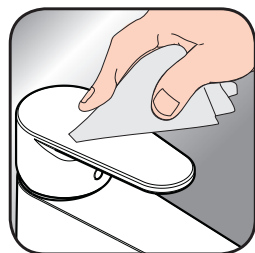

[www.hansgrohe.com/  
cleaning-recommendation](http://www.hansgrohe.com/cleaning-recommendation)



[www.hansgrohe.com/  
cleaning-recommendation](http://www.hansgrohe.com/cleaning-recommendation)



[www.hansgrohe.com/  
cleaning-recommendation](http://www.hansgrohe.com/cleaning-recommendation)

---

[www.divapor.com](http://www.divapor.com)



P-IX

DVGW SINTEF NF



ETA



GODKENDT  
TIL DRIKKEVAND

71134000 P-IX 28140/IO

X

