

OEM THERMOSTATIC MIXING VALVES

quality and reliability

Introduction

Inta's OEM thermostatic mixing valves are manufactured to EN1287 and offer the same manufacturing quality and performance you've come to expect from an inta mixing valve. OEM mixing valves offer an alternative to thermostatically protecting your installation where certification is not required.



- Temperature adjustment range 30 - 65°C
- Temperature stability $\pm 4^{\circ}\text{C}$
- Maximum static pressure 10 Bar
- Maximum dynamic pressure 5 bar
- Maximum inlet pressure differential 2:1
- Maximum inlet temperature 90°C
- Minimum temperature differential 10°C

Product Range

Description	Code
T16 thermostatic mixing valve - 1" male	60097CP
T19 thermostatic mixing valve - 3/4" male	60099CP

Line Drawings

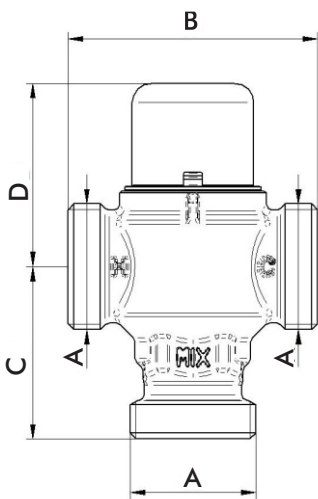

60097CP

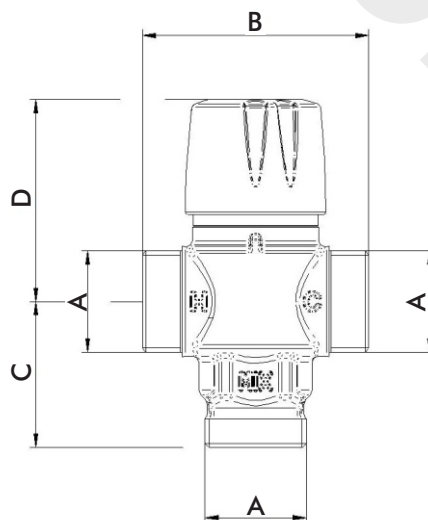

60099CP

60097CP

A	G 1" M
B	66
C	46
D	44

60099CP

A	G 3/4" M
B	59
C	38
D	MAX 57