

## inta L mix thermostatic mixing valve

### Introduction

The Intatec range of 15 and 22mm thermostatic mixing valves is designed primarily for single outlet use. It delivers safe, blended hot water to taps, showers, bidets and other water outlets.

Unlike T-pattern valves the hot and the mixed water ports are perpendicular, which reduces the need for pipework modifications and helps to save a significant amount of installation time - especially in retro fit application.

The element that controls the temperature of the mixed water discharging from the valve works proportionally on both hot and cold water supplies in order to maintain the temperature of the mixed water discharged.

delivers safe,  
**blended hot  
water** to taps,  
showers, bidets and  
other water outlets



- High flow rates with Low Pressure drops
- 15mm & 22mm versions available
- Integral Check Valves and Strainers
- Highly resistant to scaling
- Anti tamper proof head
- Robust and Reliable
- Easy installation
- Integral Check Valves and Strainers

### ■ Product Range

Description	Code
Inta L mix 15mm	60010CP
Inta L mix 22mm	60011CP



## inta L mix thermostatic mixing valve

### Technical Data

Temperature Adjustment Range	30°C to 50°C
Temperature Stability	±2°C
Maximum Inlet Temperature	85°C
Maximum Working Pressure	10 Bar : Static
Minimum Working Pressure	0.2 Bar : Dynamic
Inlet Temperature Range	55°C - 65°C : Hot 0.5°C - 20°C : Cold
Maximum Temp. Differential for fail safe	10°C
Maximum Pressure Inlet differential	5:1

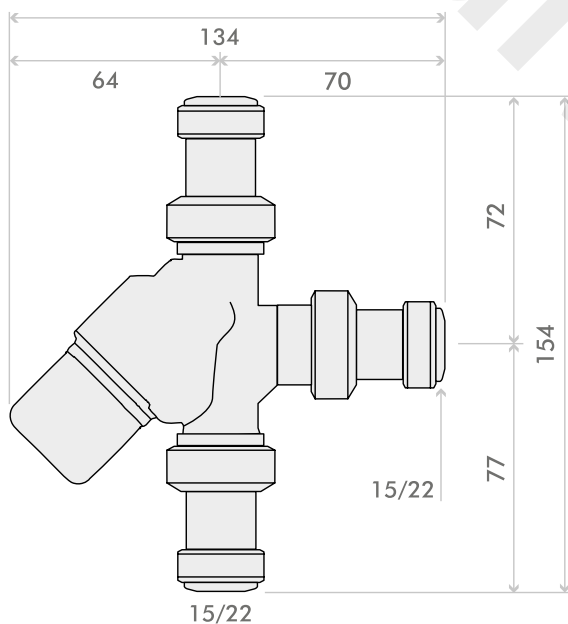

### Flow Rates

