

DE	Gebrauchsanleitung / Montageanleitung	2
FR	Mode d'emploi / Instructions de montage	2
EN	Instructions for use / assembly instructions	3
IT	Istruzioni per l'uso / Istruzioni per Installazione	3
ES	Modo de empleo / Instrucciones de montaje	4
NL	Gebruiksaanwijzing / Handleiding	4
DK	Brugsanvisning / Monteringsvejledning	5
PT	Instruções para uso / Manual de Instalação	5
PL	Instrukcja obsługi / Instrukcja montażu	6
CS	Návod k použití / Montážní návod	6
SK	Návod na použitie / Montážny návod	7
ZH	用户手册 / 组装说明	7
RU	Руководство пользователя / Инструкция по монтажу	8
FI	Käyttöohje / Asennusohje	8
SV	Bruksanvisning / Monteringsanvisning	9
LT	Vartotojo instrukcija / Montavimo instrukcijos	9
RO	Manual de utilizare / Instrucțiuni de montare	10
EL	Οδηγίες χρήσης / Οδηγία συναρμολόγησης	10
SL	Navodilo za uporabo / Navodila za montažo	11
ET	Kasutusjuhend / Paigaldusjuhend	11
LV	Lietošanas pamācība / Montāžas instrukcija	12
SR	Uputstvo za upotrebu / Uputstvo za montažu	12
NO	Bruksanvisning / Montasjeveiledning	13
BG	Инструкция за употреба / Ръководство за монтаж	13
SQ	Udhëzuesi i përdorimit / Udhëzime rreth montimit	14
AR	دليل الاستخدام / تعليمات التجميع	14
HU	Használati útmutató / Szerelési útmutató	15
JP	取扱説明書 / 施工説明書	15
TR	Kullanım kılavuzu / Montaj kılavuzu	16
HR	Upute za uporabu / Uputstva za instalaciju	17

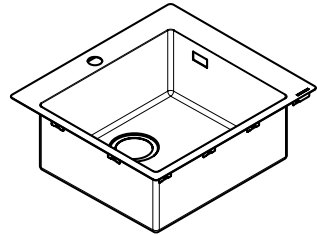

C71-F450-06	S717-F450
43201XXX	43307800
C71-F450-01	S716-F450
43207XXX	43331800
C71-F450-07	S718-F450
43205XXX	43332800
C71-F450-02	S711-F660
43208XXX	43302800
C71-F450-11	S712-F660
43229XXX	43308800
C71-F450-12	S711-F655
43230XXX	43309800
C71-F660-08	S712-F655
43202XXX	43310800
C71-F660-03	S711-F765
43209XXX	43303800
C71-F655-09	S712-F765
43206XXX	43311800
C71-F655-04	S719-U400
43210XXX	43425800
C71-F765-10	S719-U450
43203XXX	43426800
C71-F765-05	S719-U500
43211XXX	43427800
S711-F450	S719-U660
43301800	43428800
S712-F450	S719-U655
43305800	43429800
S715-F450	S719-U765
43306800	43430800



Sicherheitshinweise

- Bei der Montage müssen zur Vermeidung von Quetsch- und Schnittverletzungen Handschuhe getragen werden.

Montagehinweise

- Vor der Montage muss das Produkt auf Transportschäden untersucht werden. Nach dem Einbau werden keine Transport- oder Oberflächenschäden anerkannt.
- Die in den Ländern jeweils gültigen Installationsrichtlinien sind einzuhalten.
- Beim Einbau der Unterbauspülen in Arbeitsplatten aus Natur- oder Kunststein, Keramik oder Glas müssen die mitgelieferten Dübel mit geeignetem Kleber fixiert werden.

Symbolerklärung



Kein essigsäurehaltiges Silikon verwenden!



Maße (siehe Seite 18)



Reinigung (siehe Seite 38)



Prüfzeichen (siehe Seite 40)



Consignes de sécurité

- Lors du montage, porter des gants de protection pour éviter toute blessure par écrasement ou coupure.

Instructions pour le montage

- Avant son montage, s'assurer que le produit n'a subi aucun dommage pendant le transport. Après le montage, tout dommage de transport ou de surface ne pourra pas être reconnu.
- Les directives d'installation en vigueur dans le pays concerné doivent être respectées.
- Pour le montage d'éviers encastrés dans des plans de travail en pierre naturelle ou artificielle, céramique ou verre, les chevilles livrées doivent être fixées à l'aide d'une colle appropriée.

Description du symbole



Ne pas utiliser de silicone contenant de l'acide acétique!



Dimensions (voir pages 18)



Nettoyage (voir pages 38)



Classification acoustique et débit
(voir pages 40)



Aufliegende Montage

(siehe Seite 34)



Bündige Montage

(siehe Seite 36)



Unterbaumontage

(siehe Seite 33)



Montage en appui

(voir pages 34)



Montage affleurant

(voir pages 36)



Montage sous plan

(voir pages 33)



Safety Notes

⚠️ Gloves should be worn during installation to prevent crushing and cutting injuries.

Installation Instructions

- Prior to installation, inspect the product for transport damages. After it has been installed, no transport or surface damage will be honoured.
- The plumbing codes applicable in the respective countries must be observed.
- For installation of the underbuild unit sink in counter-tops made of natural or artificial stone, ceramics or glass, the dowels comprised in the delivery must be glued in with a suitable adhesive.

Symbol description



Do not use silicone containing acetic acid!



Dimensions (see page 18)



Cleaning (see page 38)



Test certificate (see page 40)

Indicazioni sulla sicurezza

⚠️ Durante il montaggio, per evitare ferite da schiacciamento e da taglio bisogna indossare guanti protettivi.

Istruzioni per il montaggio

- Prima del montaggio è necessario controllare che non ci siano stati danni durante il trasporto. Una volta eseguito il montaggio, non verranno riconosciuti eventuali danni di trasporto o delle superfici.
- Vanno rispettate le direttive di installazione nazionali vigenti nel rispettivo paese.
- Al montaggio dei lavelli ad incasso in piani di lavoro di pietra naturale o artificiale, ceramica o vetro, fissare assolutamente i tasselli in dotazione con adeguata colla.

Descrizione simbolo



Non utilizzare silicone contenente acido acetico!



Ingombri (vedi pagg. 18)



Pulitura (vedi pagg. 38)



Segno di verifica (vedi pagg. 40)



Surface-mounted installation
(see page 34)



Flush installation
(see page 36)



Undermount installation
(see page 33)



Montaggio appoggiato
(vedi pagg. 34)



Montaggio a filo
(vedi pagg. 36)



Montaggio a incasso
(vedi pagg. 33)



Indicaciones de seguridad

⚠ Durante el montaje deben utilizarse guantes para evitar heridas por aplastamiento o corte.

Indicaciones para el montaje

- Antes del montaje se debe examinar el producto contra daños de transporte. Después de la instalación no se reconoce ningún daño de transporte o de superficie.
- Es obligatorio el cumplimiento de las directrices de instalación vigentes en el país respectivo.
- Para el montaje bajo encimera del fregadero en planchas de piedra natural y artificial, cerámica o vidrio es necesario fijar los tacos suministrados con una cola adecuada.

Descripción de símbolos



No utilizar silicona que contiene ácido acético!



Dimensiones (ver página 18)



Limpiar (ver página 38)



Marca de verificación
(ver página 40)



Veiligheidsinstructies

⚠ Bij de montage moeten ter voorkoming van knel- en snijwonden handschoenen worden gedragen.

Montage-instructies

- Vóór de montage moet het product gecontroleerd worden op transportschade. Na de inbouw wordt geen transport- of oppervlakteschade meer aanvaard.
- De in de overeenkomstige landen geldende installatierichtlijnen moeten nageleefd worden.
- Bij de inbouw van onderbouwspoelbakken in werkbladen van natuursteen of kunststof, keramiek of glas moeten de meegeleverde bouten vastgezet worden met geschikte lijm.

Symboolbeschrijving



Gebruik geen zuurhoudende siliconen!



Maten (zie blz. 18)



Reinigen (zie blz. 38)



Keurmerk (zie blz. 40)



Montaje superpuesto
(ver página 34)



Montaje a ras
(ver página 36)



Montaje rebajado
(ver página 33)



Opbouw montage
(zie blz. 34)



Vlakke montage
(zie blz. 36)



Onderbouw montage
(zie blz. 33)



Sikkerhedsanvisninger

⚠ Ved monteringen skal der bruges handsker for at undgå kvæstelser og snitsår.

Monteringsanvisninger

- Før monteringen skal produktet kontrolleres for transportskader. Efter monteringen godkendes transportskader eller skader på overfladen ikke længere.
- Installationsbestemmelserne, der gælder i det enkelte land, skal overholdes.
- Ved montering af underlimede køkkenvaske i bordplader af natur- eller kunststen, keramik eller glas skal de medfølgende dybler fastgøres med en egnet lim.

Symbolbeskrivelse

 Der må ikke benyttes eddikesyreholdig silikone!

 **Målene** (se s. 18)

 **Rengøring** (se s. 38)

 **Godkendelse** (se s. 40)

Avisos de segurança

⚠ Durante a montagem devem ser utilizadas luvas de protecção, de modo a evitar ferimentos resultantes de entalamentos e de cortes.

Avisos de montagem

- Antes da montagem deve-se controlar o produto relativamente a danos de transporte. Após a montagem não são aceites quaisquer danos de transporte ou de superfície.
- A prescrições de instalação válidas nos respetivos países devem ser respeitadas.
- Na instalação dos lava-loiças em bancadas de pedra natural, pedra artificial, cerâmica ou vidro, as buchas fornecidas devem ser fixadas com cola adequada para o efeito.

Descrição do símbolo

 Não utilizar silicone que contenha ácido acético!

 **Medidas** (ver página 18)

 **Limpeza** (ver página 38)

 **Marca de controlo** (ver página 40)

 **Udvendigt liggende montering**
(se s. 34)

 **Plan montering**
(se s. 36)

 **Undermonteret montage**
(se s. 33)

 **Montagem de cima**
(ver página 34)

 **Montagem alinhada**
(ver página 36)

 **Montagem por baixo**
(ver página 33)

**Wskazówki bezpieczeństwa**

- △ Aby uniknąć zranień na skutek zgniecenia lub przecięcia, podczas montażu należy nosić rękawice ochronne.

Wskazówki montażowe

- Przed montażem należy skontrolować produkt pod kątem szkód transportowych. Po montażu nie widać żadnych szkód transportowych ani szkód na powierzchni.
- Należy przestrzegać wytycznych instalacyjnych obowiązujących w danym kraju.
- Przy montażu zlewów wpuszczanego w płytkach roboczych z kamienia naturalnego lub z tworzywa sztucznego, ceramiki lub szkła należy zamocować dostarczone kołki przy użyciu odpowiedniego kleju.

Opis symbolu

Nie stosować silikonów zawierających kwas octowy!



Wymiary (patrz strona 18)



Czyszczenie (patrz strona 38)



Znak jakości (patrz strona 40)

**Bezpečnostní pokyny**

- △ Pro zabránění řezným zraněním a pohmožděním je nutné při montáži nosit rukavice.

Pokyny k montáži

- Před montáží je třeba produkt zkontrolovat, zda nebyl při transportu poškozen. Po zabudování nebudou uznány žádné škody způsobené transportem nebo poškození povrchu.
- Je třeba dodržovat montážní pravidla platné v dané zemi.
- Při montáži dřezů do pracovních desek z přírodního a umělého kamene, keramiky nebo skla je nutné přiložené hmoždinky upevnit vhodným lepidlem.

Popis symbolů

Nepoužívat silikon s obsahem kyseliny octové!



Rozměry (viz strana 18)



Čištění (viz strana 38)



Zkušební značka (viz strana 40)

**Montáž na blacie**

(patrz strona 34)

**Montáž w jednej linii z blatem**

(patrz strona 36)

**Montaż pod blatem**

(patrz strona 33)

**Vestavná montáž na desku**

(viz strana 34)

**Zarovnaná montáž**

(viz strana 36)

**Spodní montáž**

(viz strana 33)



Bezpečnostné pokyny

△ Pri montáži musíte nosiť rukavice, aby ste predišli pomliaždeninám a rezným poraneniam.

Pokyny pre montáž

- Pred montážou musíte produkt skontrolovať, či nebol počas transportu poškodený. Po zabudovaní nebudú uznané žiadne škody spôsobené transportom alebo poškodenia povrchu.
- Je potrebné dodržiavať smernice o inštalácii, ktoré sú práve teraz platné v krajinách.
- Pri montáži zabudovaných výleviek do pracovných dosiek z prírodného alebo umelého kameňa, keramiky alebo skla musíte dodané hmoždinky zaistiť pomocou vhodného lepidla.

Popis symbolov

 Nepoužívať silikón s obsahom kyseliny octovej!

 **Rozmery** (viď strana 18)

 **Čistenie** (viď strana 38)

 **Osvedčenie o skúške**
(viď strana 40)

安全技巧

△ 装配时为避免挤压和切割受伤，必须戴上手套。

安装提示

- 安装前必须检查产品是否受到运输损害。安装后将不认可运输损害或表面损伤。
- 请遵守当地国家现行的安装规定。
- 在由天然石材或人造石材、陶瓷或玻璃制成的工作台安装底层地板时，必须用合适的胶固定所提供的销钉。

符号说明

 请勿使用含有乙酸的硅胶！

 大小 (参见第 18 页)

 清洗 (参见第 38 页)

 检验标记 (参见第 40 页)

 **Montáž nasadením zvrchu**
(viď strana 34)

 **Montáž do jednej roviny**
(viď strana 36)

 **Montáž nasadením zospodu**
(viď strana 33)

 **表面贴装**
(参见第 34 页)

 **嵌入式安装**
(参见第 36 页)

 **台下安装**
(参见第 33 页)



Указания по технике безопасности

Во время монтажа следует надеть перчатки во избежание прищемления и порезов.

Указания по монтажу

- Перед монтажом следует проверить изделие на предмет повреждений при перевозке. После монтажа претензии о возмещении ущерба за повреждения при перевозке или повреждения поверхностей не принимаются.
- Необходимо соблюдать требования по монтажу, действующие в соответствующих странах.
- Если встраиваемые раковины встраиваются в столешницы из натурального или искусственного камня, керамики или стекла, дюбели, входящие в комплект, нужно зафиксировать при помощи специального клея.

Описание символов



Не применяйте силикон, содержащий уксусную кислоту.



Размеры (см. стр. 18)



Очистка (см. стр. 38)



Знак технического контроля
(см. стр. 40)



Turvallisuusohjeet

Asennuksessa on käytettävä käsineitä puristumien ja viiltojen aiheuttamien tapaturmien estämiseksi.

Asennusohjeet

- Ennen asennusta on tarkastettava tuotteen mahdolliset kuljetusvahingot. Asennuksen jälkeen kuljetus- ja pintavaurioita ei hyväksytä.
- Jokaisessa maassa on noudatettava siellä päteviä asennusohjeita.
- Kun päällyksilevyn alle kiinnitettävät tiskialtaat kiinnitetään luonnon- tai keinokivisiin, keramisiin tai lasisiin levyateriaaleihin, mukana toimitetut kiinnitystapit on kiinnitettävä soveltuvalla liimalla.

Merkin kuvaus



Älä käytä etikkahappopitoista silikonialta!



Mitat (katso sivu 18)



Puhdistus (katso sivu 38)



Koestusmerkki (katso sivu 40)



Монтаж на поверхности
(см. стр. 34)



Монтаж на одном уровне
(см. стр. 36)



Встраиваемая конструкция
(см. стр. 33)



Asennus pinnan päälle
(katso sivu 34)



Asennus pinnan tasoon
(katso sivu 36)



Asennus levyn alle
(katso sivu 33)



Säkerhetsanvisningar

⚠ Handskar ska bäras under monteringsarbetet så att man kan undvika kläm- och skärskador.

Monteringsanvisningar

- Det måste undersökas om produkten har transportskador innan den monteras. Efter monteringen accepteras inga transport- eller ytskiktsskador.
- De installationsriktlinjer som gäller i länderna ska följas.
- Om vaskar ska monteras i arbetsbänkar av natursten, plastmaterial, keramik eller glas måste medföljande dyblar fixeras med lämpligt lim.

Symbolförklaring

 Använd inte silikon som innehåller ättiksyra!

 **Måtten** (se sidan 18)

 **Rengöring** (se sidan 38)

 **Testsigill** (se sidan 40)

Saugumo technikos nurodymai

⚠ Apsaugai nuo užspaudimo ir įsijovavimo montavimo metu mūvėkite pirštines.

Montavimo instrukcija

- Prieš montuojant būtina patikrinti, ar gaminyje nebuvo pažeistas transportavimo metu. Sumontavus pretenzijos dėl transportavimo ir paviršiaus pažeidimų nepriimamos.
- Laikykitės atitinkamoje šalyje galiojančių direktyvų dėl įrengimo.
- Montuojant įleidžiamas plautuves į natūralaus ar dirbtinio akmens, keramikos ar stiklo stalviršius, tinkamai klijuojami turi būti pritvirtinti patiekiami kaiščiai.

Simbolio aprašymas

 Nenaudokite silikono, kurio sudėtyje yra acto rūgšties!

 **Išmatavimai** (žr. psl. 18)

 **Valymas** (žr. psl. 38)

 **Bandymo pažyma** (žr. psl. 40)

 **Påliggande montering**
(se sidan 34)

 **Montering i linje**
(se sidan 36)

 **Infälld montering**
(se sidan 33)

 **Montavimas ant viršaus**
(žr. psl. 34)

 **Montavimas suleidžiant**
(žr. psl. 36)

 **Montavimas įleidžiant gilyn**
(žr. psl. 33)

**Instrucțiuni de siguranță**

⚠ La montare utilizați mănuși pentru evitarea contuziunilor și tăierii mâinilor.

Instrucțiuni de montare

- Înainte de instalare verificați, dacă produsul prezintă deteriorări de transport. După instalare garanția nu acoperă deteriorările de transport și cele de suprafață.
- Respectați reglementările referitoare la instalare valabile în țara respectivă.
- La montarea chiuvetelor încorporate în blaturile de piatră naturală sau artificială, de ceramică sau sticlă trebuie să fixați diblurile incluse în furnitură cu un adeziv corespunzător.

Descrierea simbolurilor

Nu utilizați silicon cu conținut de acid acetic!



Dimensiuni (vezi pag. 18)



Curățare (vezi pag. 38)



Certificat de testare (vezi pag. 40)

**Υποδειξεις ασφαλείας**

⚠ Για να αποφύγετε τραυματισμούς κατά τη συναρμολόγηση πρέπει να φοράτε γάντια.

Οδηγίες συναρμολόγησης

- Πριν τη συναρμολόγηση πρέπει να εξεταστεί το προϊόν για ζημιές μεταφοράς. Μετά την εγκατάσταση δεν αναγνωρίζονται ζημιές από τη μεταφορά ή επιφανειακές ζημιές.
- Θα πρέπει να τηρούνται οι οδηγίες εγκατάστασης που ισχύουν σε κάθε κράτος.
- Κατά την τοποθέτηση του νεροχύτη κάτω από πάγκους εργασίας από φυσικό ή συνθετικό μάρμαρο, κεραμική ή γυάλινη επιφάνεια πρέπει τα βύσματα που παραδίδονται μαζί να στερεώνονται με κατάλληλη κόλλα.

Περιγραφή συμβόλων

Μην χρησιμοποιείτε σιλικόνη που περιέχει οξικό οξύ!



Διαστάσεις (βλ. Σελίδα 18)



Καθαρισμός (βλ. Σελίδα 38)



Σήμα ελέγχου (βλ. Σελίδα 40)

**Montare deasupra blatului**

(vezi pag. 34)

**Montare la nivel cu blatul**

(vezi pag. 36)

**Montare sub blat**

(vezi pag. 33)

**Τοποθέτηση επάνω στον πάγκο εργασίας** (βλ. Σελίδα 34)**Τοποθέτηση πρόσωπο με τον πάγκο εργασίας** (βλ. Σελίδα 36)**Τοποθέτηση κάτω από τον πάγκο εργασίας** (βλ. Σελίδα 33)



Varnostna opozorila

⚠ Pri montaži je treba nositi rokavice, da se preprečijo poškodbe zaradi zmečkanja ali urezov.

Navodila za montažo

- Pred montažo je treba izdelek preveriti glede morebitnih transportnih poškodb. Po vgradnji transportne ali površinske poškodbe ne bodo več priznane.
- Upoštevati je treba pravilnike o inštalacijah, ki veljajo v posamezni državi.
- Pri vgradnji podpultnih umivalnikov v delovne plošče iz naravnega ali umetnega kamna, keramike ali stekla se morajo priloženi mozniki fiksirati s primernim lepilom.

Opis simbola



Ne smete uporabiti silikona, ki vsebuje ocetno kislino!



Mere (glejte stran 18)



Čiščenje (glejte stran 38)



Preskusni znak (glejte stran 40)

Ohutusjuhised

⚠ Kandke paigaldamisel muljumis- ja löikevigastuste vältimiseks kindaid.

Paigaldamisjuhised

- Enne paigaldamist tuleb toodet kontrollida transportdikahjustuste osas. Pärast paigaldamist ei tunnustata enam transporti- või pinnakahjustuste kaebuseid.
- Vastavas riigis kehtivaid paigalduseeskirju tuleb järgida.
- Kraanikausialuse kapi paigaldamisel naturaalsest või kunstivist, keramilise või klaasist tööpinna alla tuleb kaasa antud tüüblid fikseeritud sobiva kleebisega.

Sümbolite kirjeldus



Ärge kasutage äädikhapet sisaldavat silikooni!



Mõõtude (vt lk 18)



Puhastamine (vt lk 38)



Kontrollsertifikaat (vt lk 40)



Naležna montaž
(glejte stran 34)



Poravnana montaž
(glejte stran 36)



Podometna montaž
(glejte stran 33)



Pealepaigaldus
(vt lk 34)



Kohakuti paigaldus
(vt lk 36)



Allapaigaldus
(vt lk 33)



Drošības norādes

⚠ Montāžas laikā, lai izvairītos no saspiedumiem un iegriezumiem, nepieciešams nēsāt cimdus.

Norādījumi montāžai

- Pirms montāžas nepieciešams pārbaudīt, vai produktam transportēšanas laikā nav radušies bojājumi. Pēc iebūvēšanas bojājumi, kas radušies transportēšanas laikā, vai virsmas bojājumi netiek atzīti.
- Jāievēro attiecīgās valstīs spēkā esošās montāžas prasības.
- Iebūvējot izlietni galdā virsmā no dabīgā vai mākslīgā akmens, keramikas vai stikla, komplektā esošie dibelji jānofiksē ar piemērotu līmi.

Simbolu nozīme



Neizmantojot silikonu, kas satur etiķskābi!



Izmērus (skat. lpp. 18)



Tīrīšana (skat. lpp. 38)



Pārbaudes zīme (skat. lpp. 40)



Sigurnosne napomene

⚠ Prilikom montaže se radi sprečavanja prignječenja i posekotina moraju nositi rukavice.

Instrukcije za montažu

- Pre montaže se mora proveriti da li je proizvod oštećen pri transportu. Nakon ugradnje se ne priznaju nikakve reklamacije koje se odnose na površinska i transportna oštećenja.
- Treba se pridržavati propisa koji u određenim zemljama važe za instalacije.
- Prilikom ugradnje podpultnih sudopera ispod radne ploče od prirodnog ili veštačkog kamena, keramike ili stakla, isporučeni moždanici moraju se fiksirati odgovarajućim lepkom.

Opis simbola



Nemojte koristiti silikon koji sadrži sirćetnu kiselinu!



Mere (vidi stranu 18)



Čišćenje (vidi stranu 38)



Ispitni znak (vidi stranu 40)



Montāža uz virsmas

(skat. lpp. 34)



Montāža vienā līmeī

(skat. lpp. 36)



Iebūvējama konstrukcija

(skat. lpp. 33)



Nadpultna montaža

(vidi stranu 34)



Nadovezujuća montaža

(vidi stranu 36)



Podpultna montaža

(vidi stranu 33)



Sikkerhetshenvisninger

- △ Bruk hansker under montasjen for å unngå klem- og kuttskader.

Montagehenvisninger

- Før montasjen skal produktet sjekkes for transportskader. Etter monteringen aksepteres ikke noen transport- eller overflateskader.
- Gjeldende retningslinjer for rørleggerarbeid i de enkelte land skal følges.
- Ved montering av undermontert vask i benplater av natur- eller kunststein, keramikk eller glass må de medfølgende pluggene festes med egnet lim.

Symbolbeskrivelse



Ikke bruk silikon som inneholder eddiksyre!



Mål (se side 18)



Rengjøring (se side 38)



Prøvemerke (se side 40)

Указания за безопасност

- △ При монтажа трябва да се носят ръкавици, за да се избегнат наранявания поради притискане или порязване.

Указания за монтаж

- Преди монтажа продуктът трябва да се провери за транспортни щети. След монтажа не се признават транспортни или повърхностни щети.
- Трябва да бъдат спазвани валидните в съответните страни предписания за инсталиране.
- При монтажа на вградени мивки в работни плотове от естествен или изкуствен камък, керамика или стъкло доставените дюбели трябва да бъдат фиксирани с подходящо лепило.

Описание на символите



Не използвайте силикон, съдържащ оцветна киселина!



Размери (вижте стр. 18)



Почистване (вижте стр. 38)



Контролен знак (вижте стр. 40)



utenpåliggende montering

(se side 34)



flush montering

(se side 36)



underliggende montering

(se side 33)



лежаш монтаж

(вижте стр. 34)



плътен монтаж

(вижте стр. 36)



монтаж под мазилка

(вижте стр. 33)



Udhëzime sigurie

△ Për të evituar lëndimet e pickimeve ose të prerjeve gjatë procesit të montimit duhet që të vishni doreza.

Udhëzime për montimin

- Përpara montimit duhet që produkti të kontrollohet për dëmtime nga transporti. Pas instalimit nuk do të njihet asnjë dëmtim nga transporti ose dëmtim i sipërfaqes.
- Duhet të respektohen linjat udhëzuese të instalimit, të vlefshme për vendet respektive.
- Gjatë montimit të lavapijatave inkaso në pllakat e vendosjes prej guri natyror ose artificial, qeramike ose xhami duhet që upat e lëvruara të fiksohen me ngjitës të përshtatshëm.

Përshkrimi i simbolit



Mos përdorni silikon që në përbërje ka acid acetik.



Përmasat (shih faqen 18)



Pastrimi (shih faqen 38)



Shenja e kontrollit (shih faqen 40)



تنبيهات الأمان

△ يجب ارتداء قفازات لليد أثناء التركيب لتجنب حدوث أضرار الإنحشار أو الجروح.

تعليمات التركيب

- قبل القيام بعملية التركيب، يجب فحص المنتج للتأكد من خلوّه من أية تلفيات ناتجة عن النقل. بعد القيام بعملية التركيب، لن يتم الاعتراف بوجود أية تلفيات سطحية أو تلفيات ناتجة عن عملية النقل.
- يجب مراعاة القواعد الخاصة بالتركيب وأعمال السباكة وفقاً للوائح الخاصة بكل بلد.
- عند تركيب أحواض التركيب السفلي في أسطح العمل المصنوعة من الحجر الطبيعي أو الاصطناعي، أو السيراميك أو الزجاج فإنه يجب تثبيت الخوابير المرفقة باستخدام مادة لاصقة مناسبة.

وصف الرمز

هام! لا تستخدم السليكون الذي يحتوي على أحماض!



أبعاد (راجع صفحة 18)



التنظيف (راجع صفحة 38)



شهادة اختبار (راجع صفحة 40)



Monti i vendosur

(shih faqen 34)



Montim i bashkuar

(shih faqen 36)



Montim nën strukturë

(shih faqen 33)



التركيب الفوقي

(راجع صفحة 34)



التركيب المستوي

(راجع صفحة 36)



التركيب التحتي

(راجع صفحة 33)

**Biztonsági utasítások**

△ A szerelésnél a zúzódások és vágási sérülések elkerülése érdekében kesztyűt kell viselni.

Szerelési utasítások

- A szerelés előtt ellenőrizni kell, hogy a terméknek nincs-e szállítási sérülése. Beépítés után a szállítási vagy felületi sérüléseket nem ismerik el.
- Az egyes országokban érvényes installációs irányelveket be kell tartani.
- A természetes- vagy műkö, kerámia vagy üveg munkalapba alulról beépített mosogatók beszerelésekor a mellékelt tipliket megfelelő ragasztóval rögzíteni kell.

Szimbólumok leírása

Ne használjon ecetsavtartalmú szilikon!



Méretet (lásd a oldalon 18)



Tisztítás (lásd a oldalon 38)



Vizsgajel (lásd a oldalon 40)

**安全上の注意**

△ 施工の際は手を挟んだり怪我をしないように、手袋をはめてください。

施工上の注意

- 製品の施工前に輸送でのダメージがないか確認してください。施工後のキズ等のお申し出はお断りさせて頂いています。
- 施工行う地域に適用される関連法規をお守りください。
- 天然または人工 (大理) 石、セラミックまたはガラスでできたワークトップにアンダーカウンターをシンクを取り付ける場合は、付属のプラグ (アンカー) を適切な接着剤で固定してください。

アイコンの説明

酢酸系シリコンをご使用にならないでください!



寸法 (次のページを参照 18)



お手入れ方法

(次のページを参照 38)



認証について

(次のページを参照 40)



Felfekvő szerelés

(lásd a oldalon 34)



Egy síkban szerelés

(lásd a oldalon 36)



Aláépített szerelés

(lásd a oldalon 33)



オーバーカウンター施工

(次のページを参照 34)



埋込施工

(次のページを参照 36)



アンダーカウンター施工の場合

(次のページを参照 33)



Güvenlik uyarıları

- Montaj esnasında ezilme ve kesilme gibi yaralanmaları önlemek için eldiven kullanılmalıdır.

Montaj açıklamaları

- Montaj işleminden önce ürün nakliye hasarları yönünden kontrol edilmelidir. Montaj işleminden sonra nakliye veya yüzey hasarları için sorumluluk üstlenilmemektedir.
- Ülkelerde geçerli kurulum yönetmeliklerine riayet edilmelidir.
- Gömme evyeleri, doğal veya yapay taştan, seramik veya cam çalışma tezgahlarına monte ederken birlikte teslim edilen dübeller uygun bir yapıştırıcıyla sabitlenmelidir.

Simge açıklaması



Asetik asit içeren silikon kullanmayın!



Ölçüleri (bakınız sayfa 18)



Temizleme (bakınız sayfa 38)



Kontrol işareti (bakınız sayfa 40)

Garanti Belgesi

Üretici veya İthalatçı Firmanın

Unvanı: Hansgrohe Armatür Ltd. Şti
Adresi: Fulya Mahallesi Bahçeler Sokak Efe han 20/C
Mecidiyeköy Şişli İstanbul
Telefonu: (0-212) 273 07 30
Faks: (0-212) 273 07 40
web adresi: www.hansgrohe.com.tr

Malın

Markası: Hansgrohe
Cinsi: Sıhhi tesisat malzemesi
Garanti Süresi: 2 YIL
Azami Tamir Süresi: 20 İş günü

Genel Müdür

Albert Emlek

Satıcı Firmanın:

Unvanı:

Adresi:

Telefonu:

Faks:

e-posta:

Fatura Tarih ve Sayısı:

Marka ve Modeli:

Teslim Tarihi ve Yeri:

Yetkilinin İmzası:

Firmanın Kaşesi:

Bu bölümü, ürünü aldığınız Yetkili Satıcı imzalayacak ve kaşeleyecektir.



Tezgaah üzerinde montaj

(bakınız sayfa 34)



Tezgaaha sıfır montaj

(bakınız sayfa 36)



Tezgaah altı montaj

(bakınız sayfa 33)



Sigurnosne upute

⚠ Prilikom montaže se radi sprječavanja prignječenja i posjekotina moraju nositi rukavice.

Upute za montažu

- Prije montaže mora se provjeriti je li proizvod oštećen prilikom transporta. Nakon ugradnje se ne priznaju nikakve reklamacije koje se odnose na površinska i transportna oštećenja.
- Obvezno se moraju uvažiti propisi o instalacijama koji vrijede u dotičnoj zemlji.
- Za ugradnju podžbuknog sudopera u radne ploče od prirodnog ili umjetnog kamena, keramike ili stakla, isporučene moždanike treba pričvrstiti odgovarajućim ljepilom.

Opis simbola



Nemojte koristiti silikon koji sadrži octenu kiselinu!



Mjere (pogledaj stranicu 18)



Čišćenje (pogledaj stranicu 38)



Oznaka testiranja
(pogledaj stranicu 40)



Nadpultna montaža
(pogledaj stranicu 34)



Montaža u ravnini
(pogledaj stranicu 36)



Podpultna montaža
(pogledaj stranicu 33)

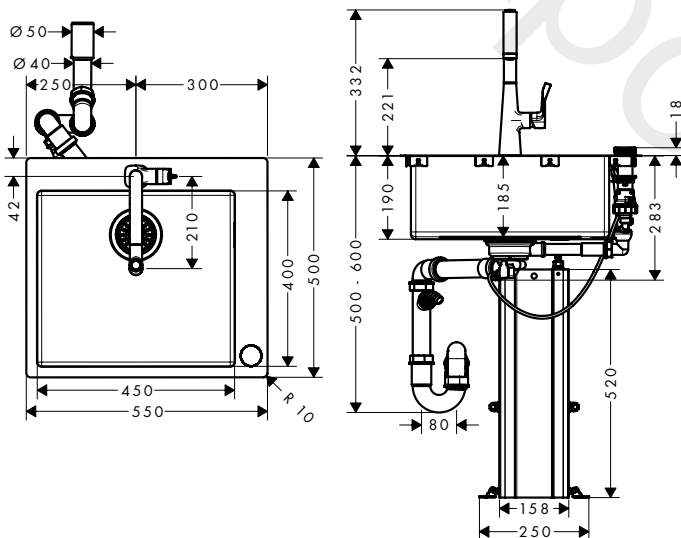
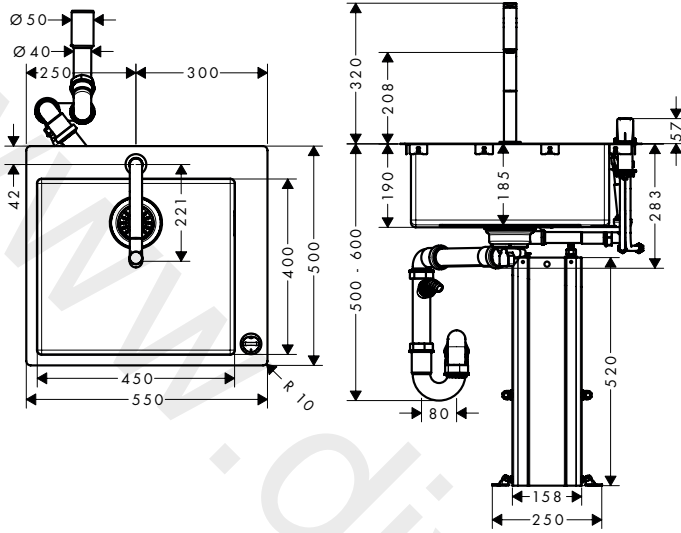

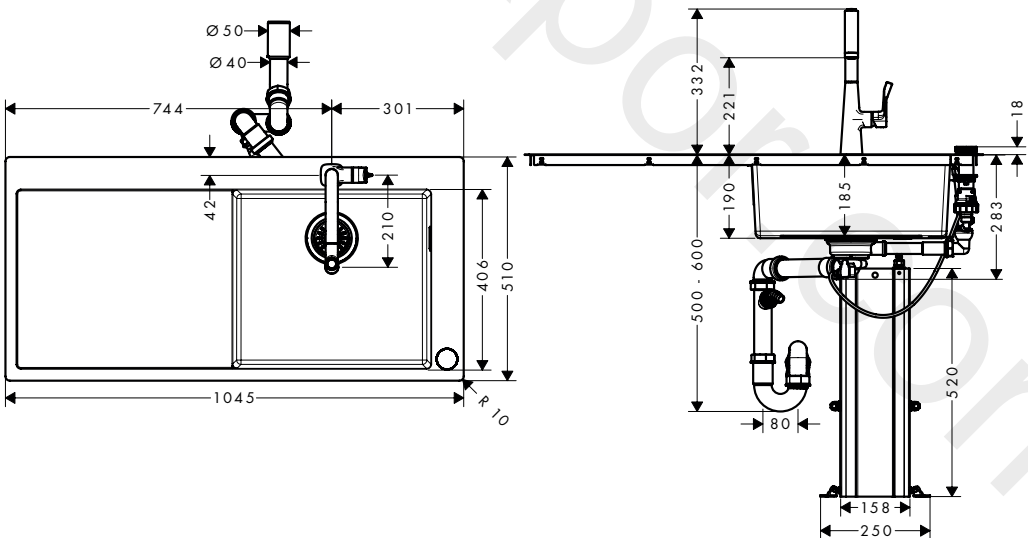
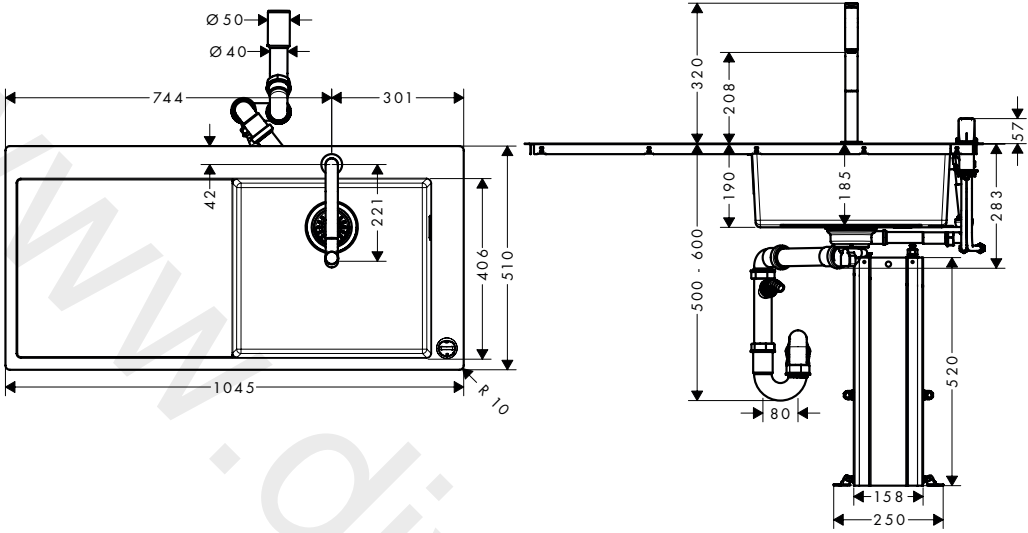



C71-F450-12 43230XXX

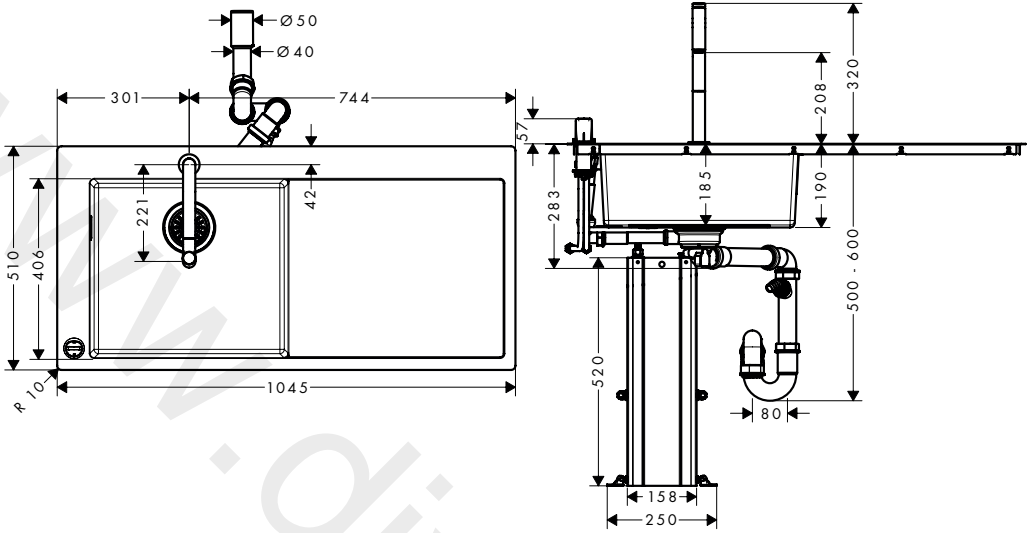

C71-F450-11 43229XXX

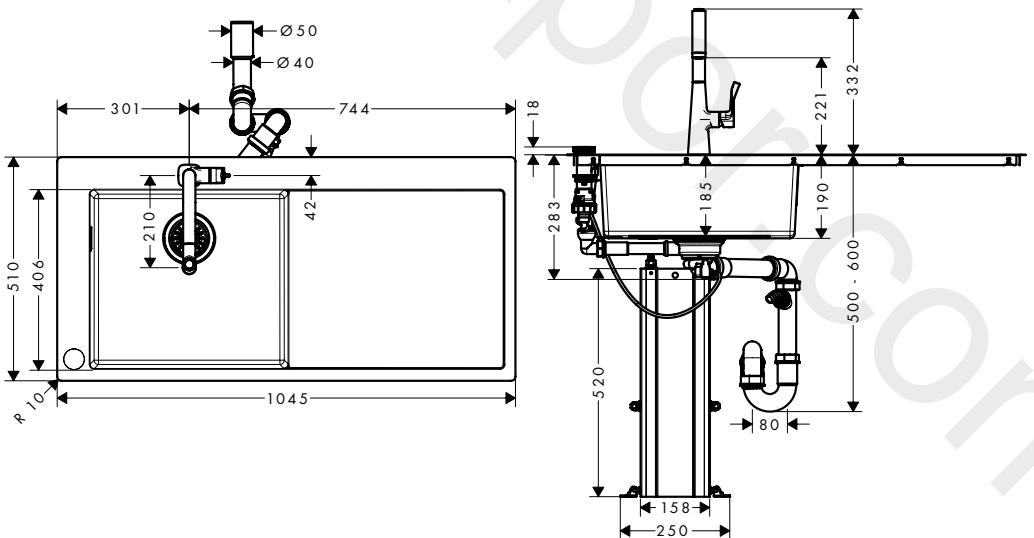

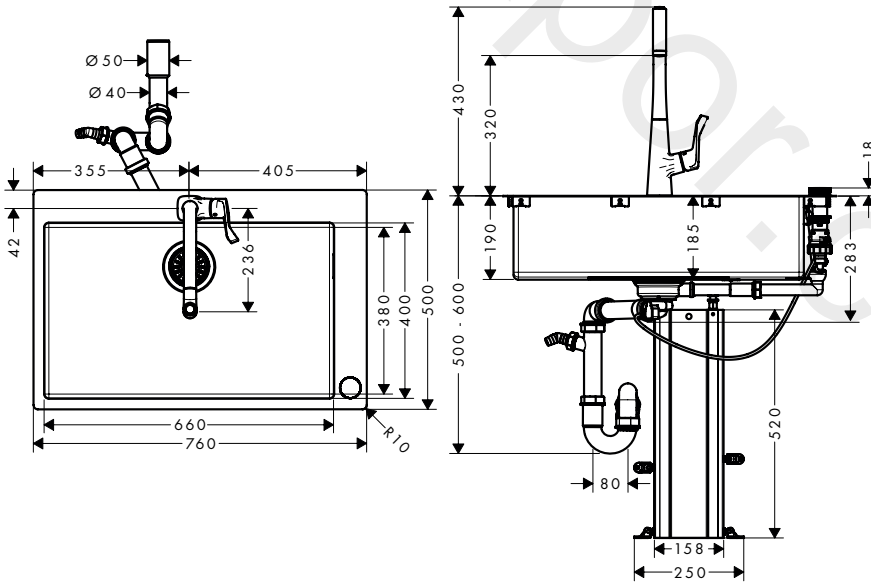
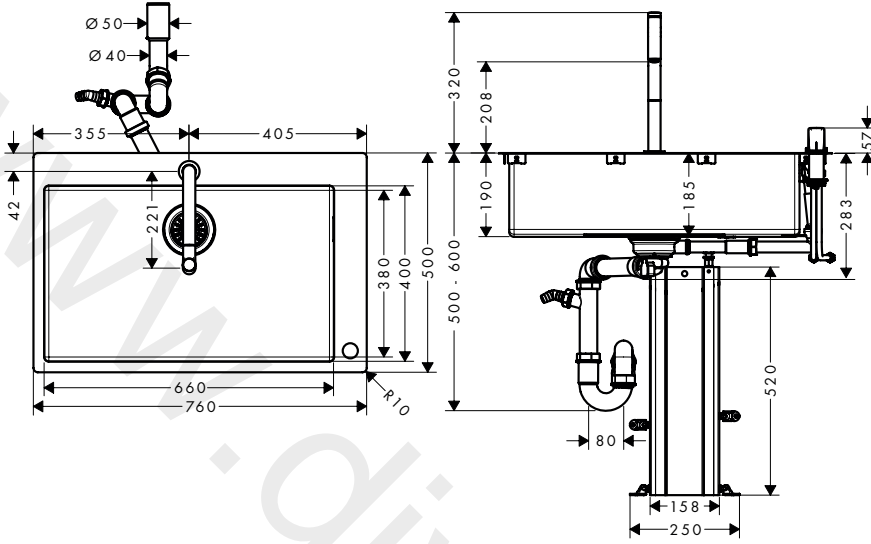

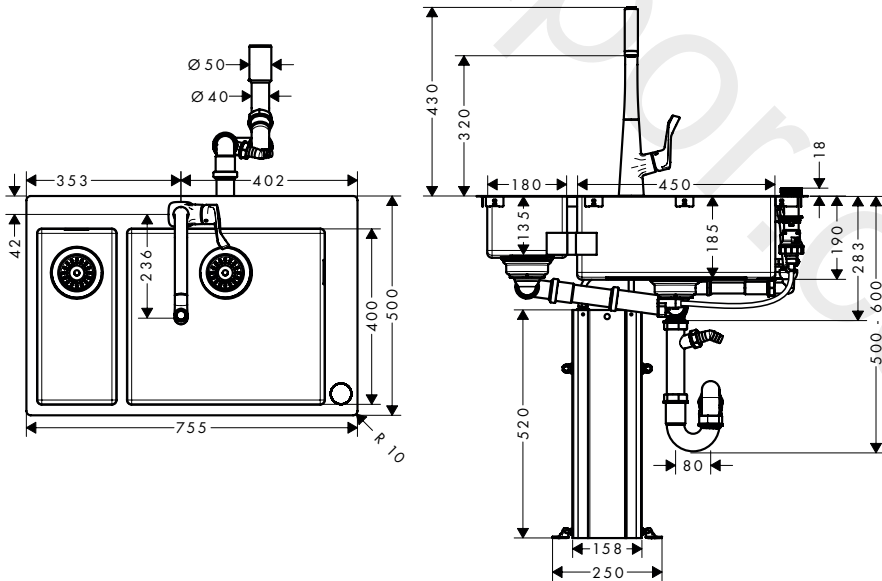
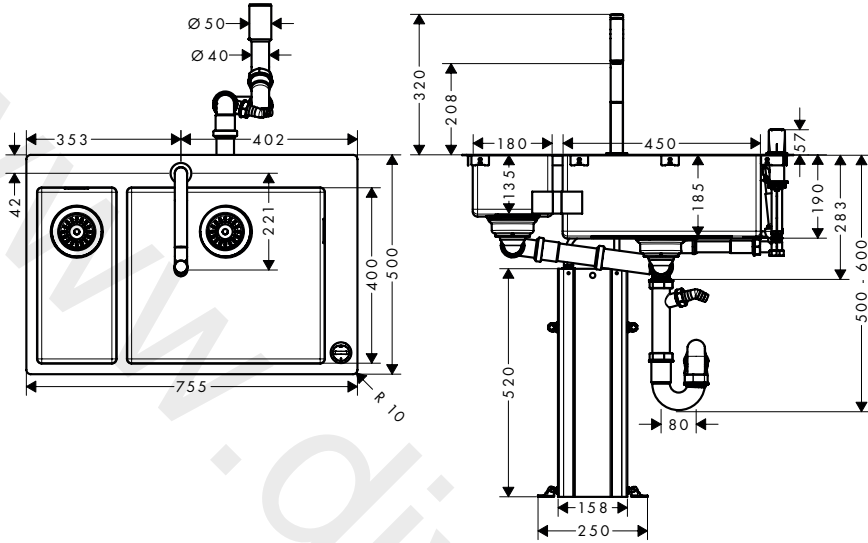

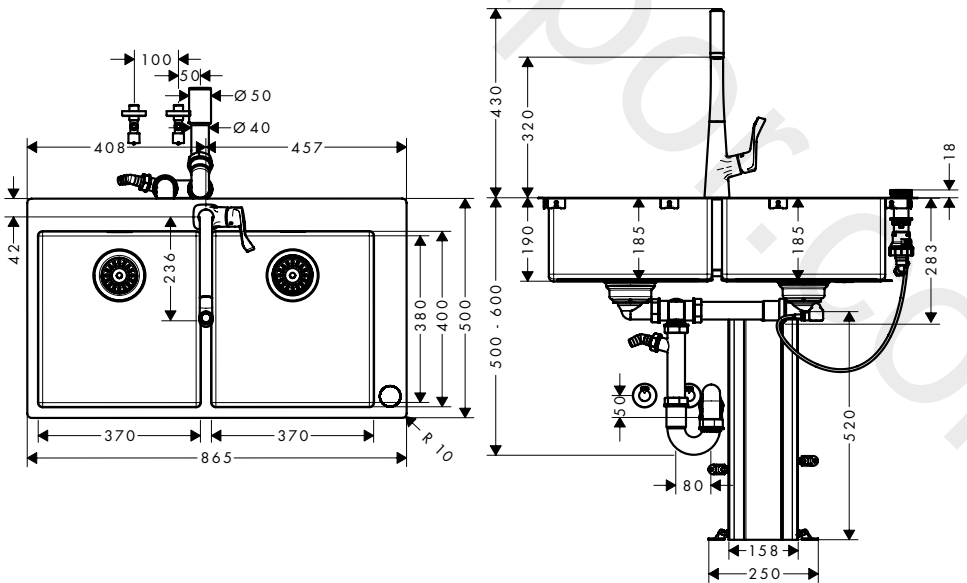
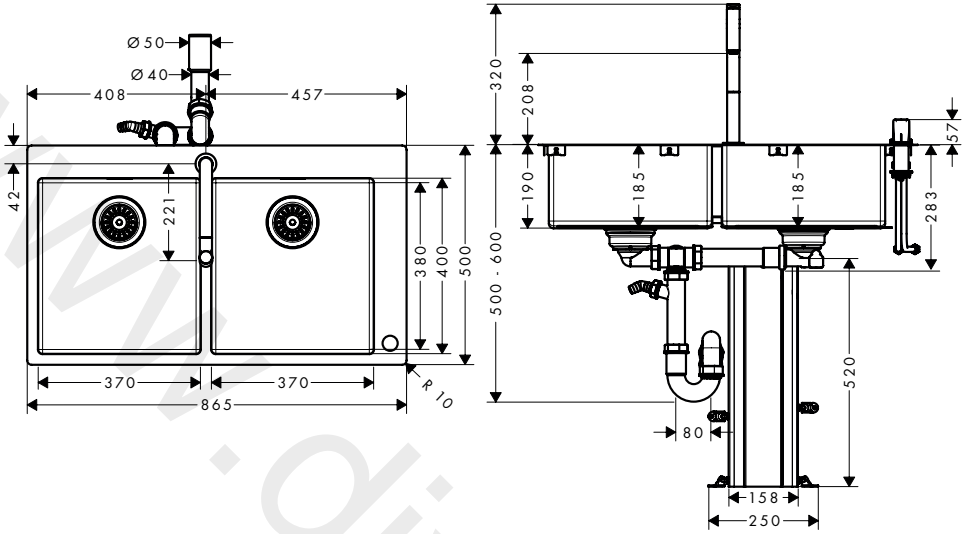

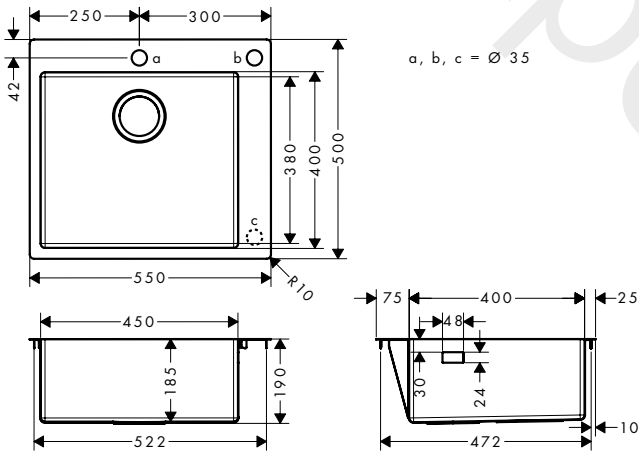
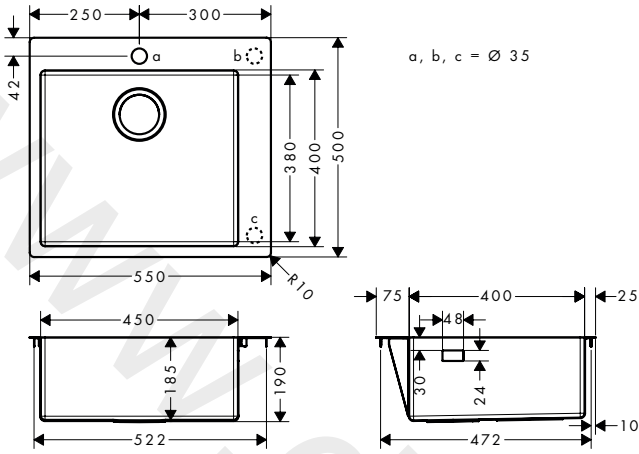

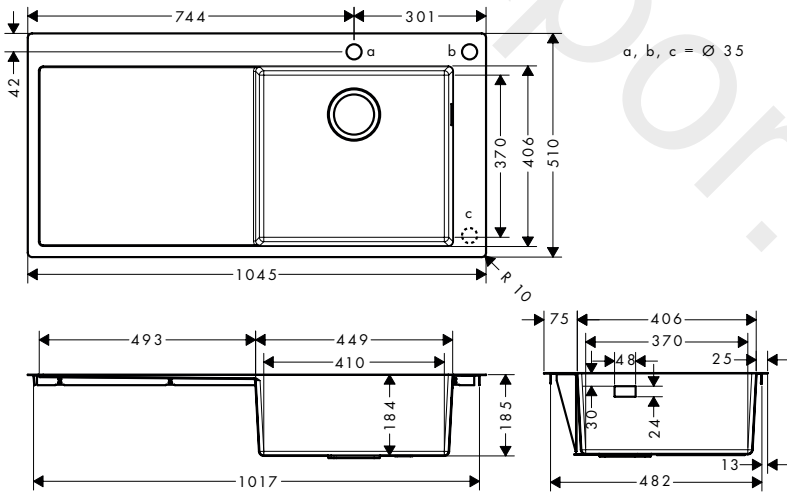
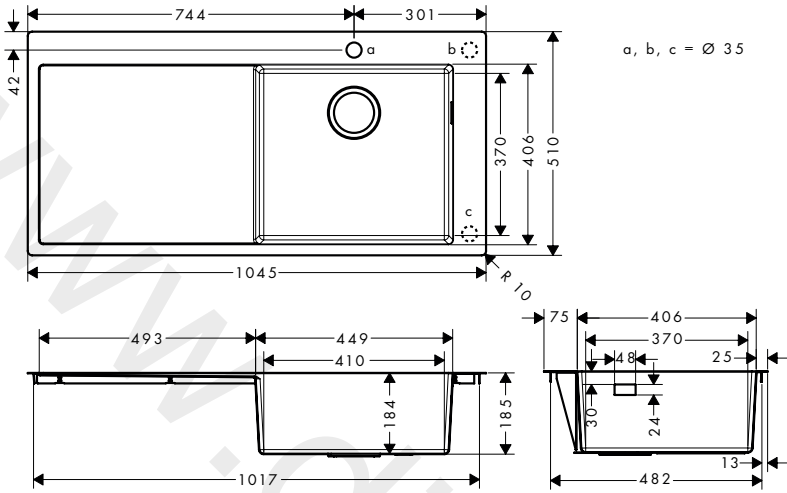

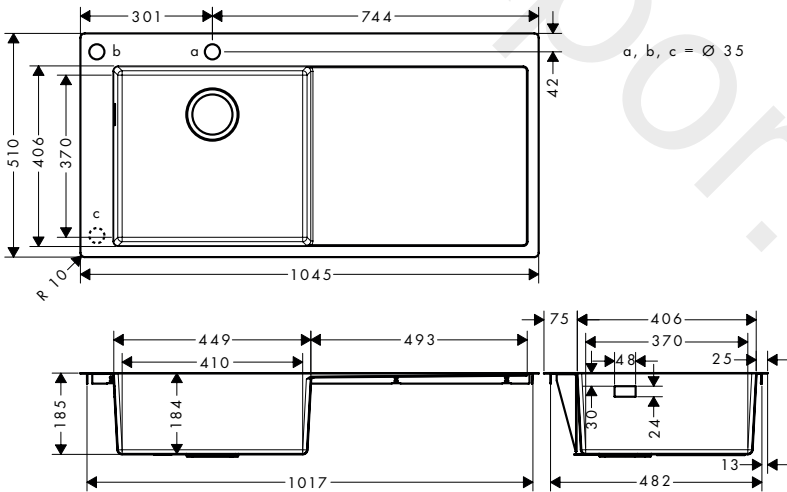
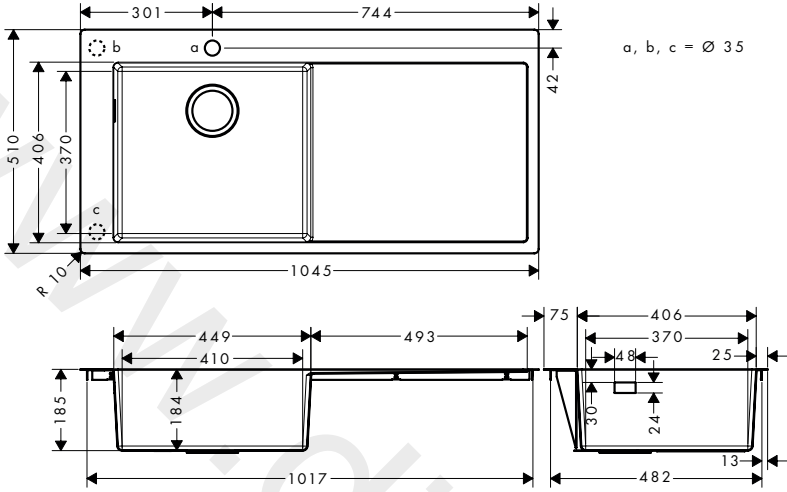

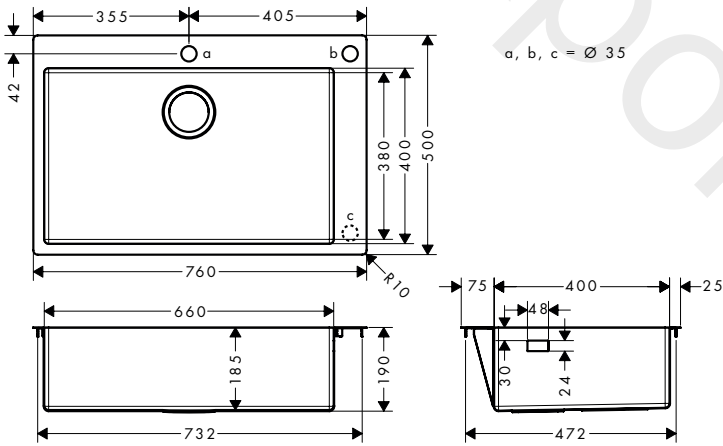
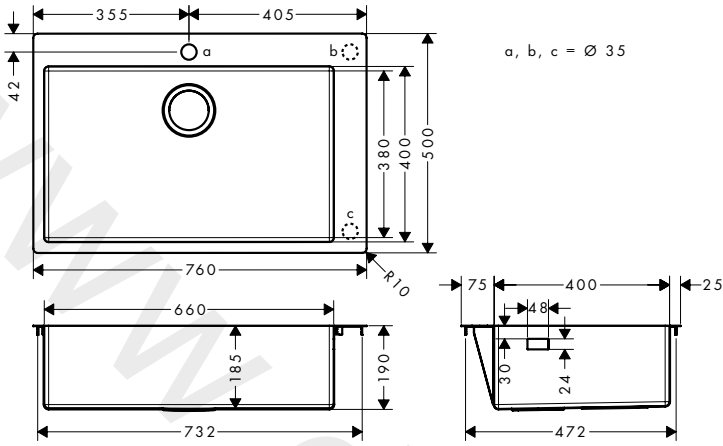

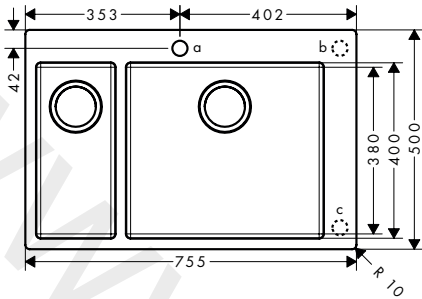

a, b, c = \varnothing 35

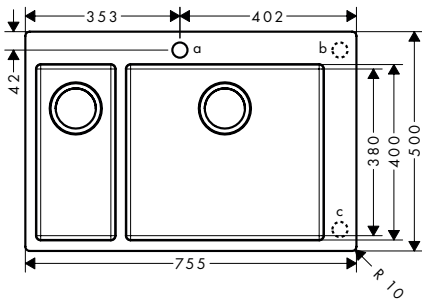
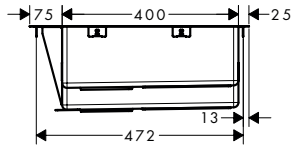
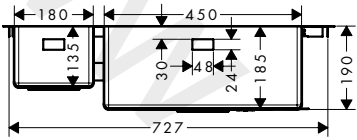

a, b, c = \varnothing 35

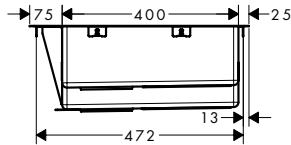
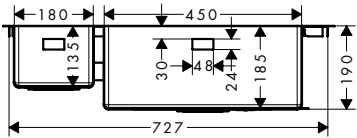

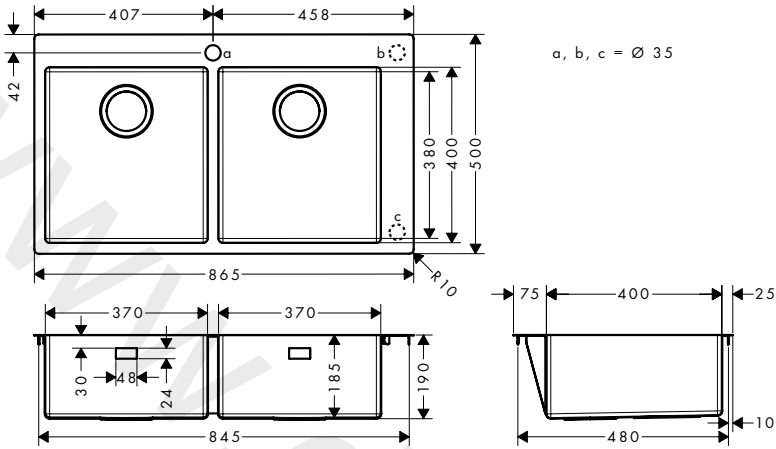

S712-F765 43311800

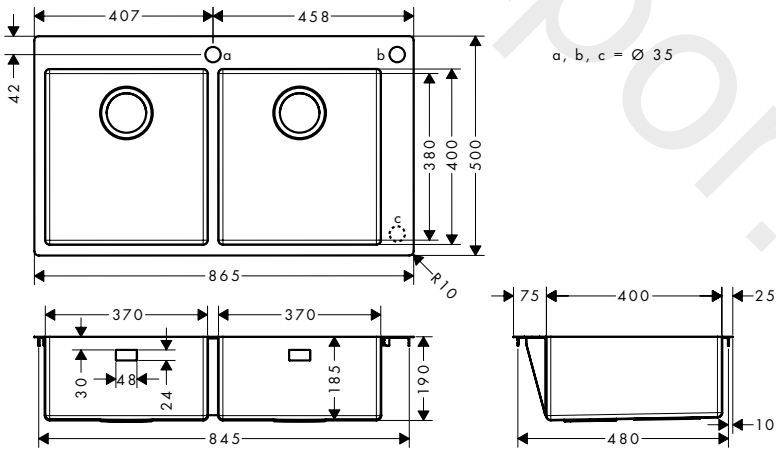

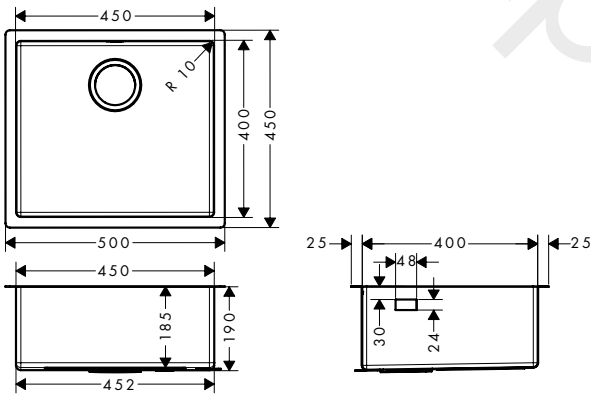
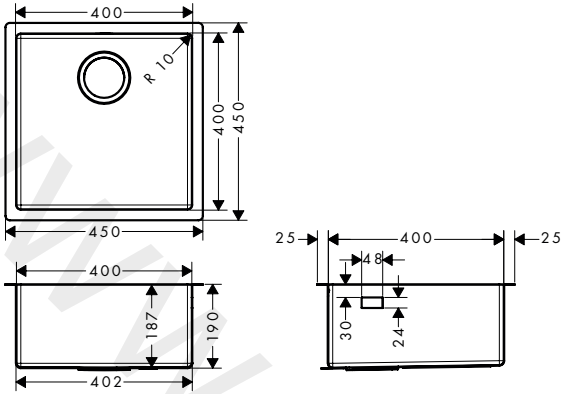

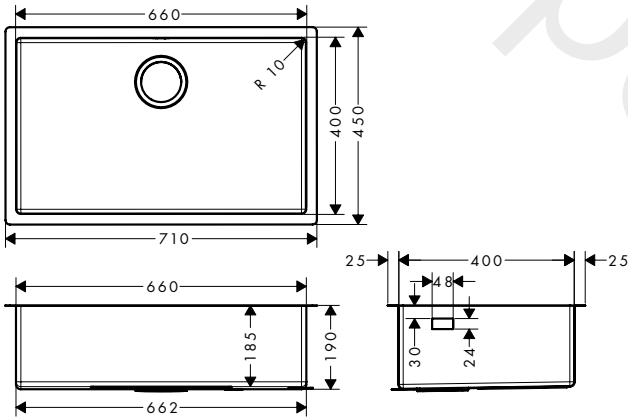
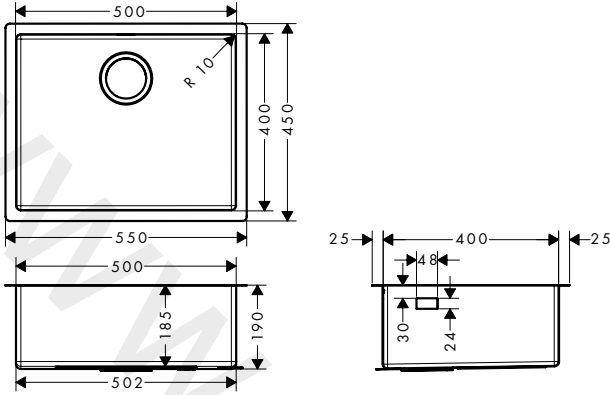

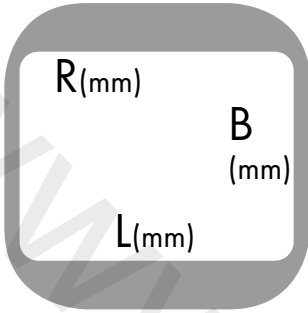

		L	B	R
S719-U400 43425800		398	398	8
S719-U450 43426800		448	398	8
S719-U500 43427800		498	398	8
S719-U660 43428800		658	398	8
S719-U655 43429800		653	398	8
S719-U765 43430800		763	398	8

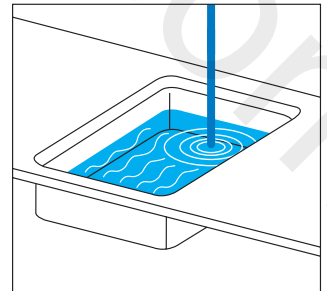
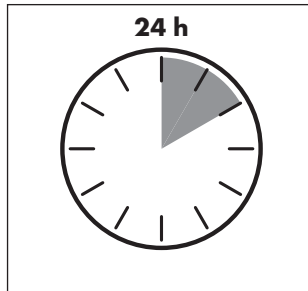
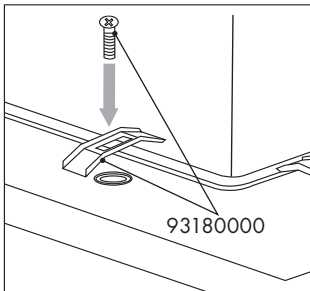
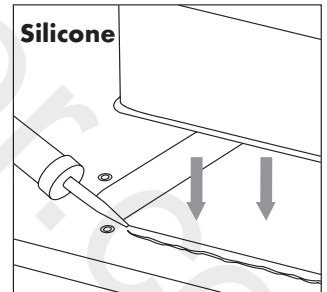
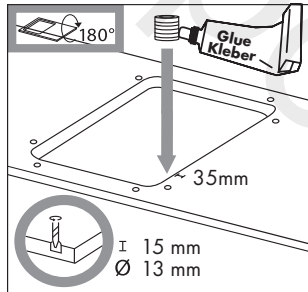
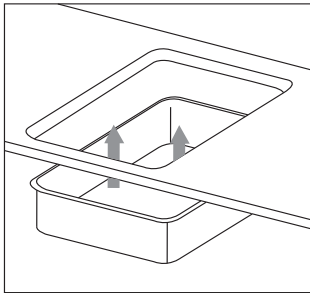

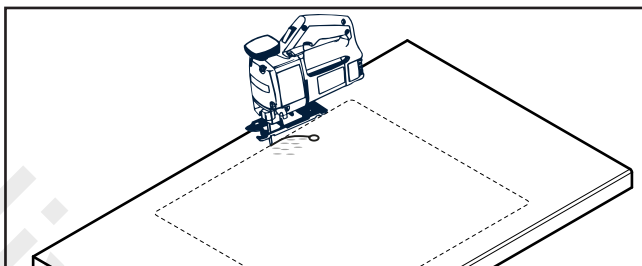
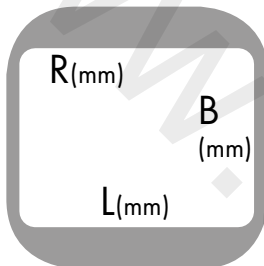
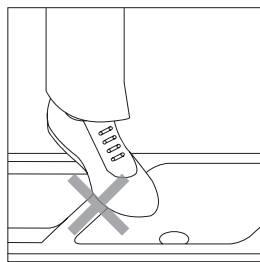
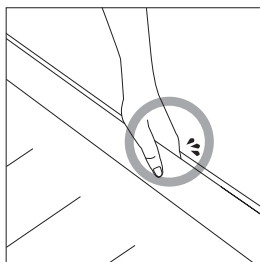
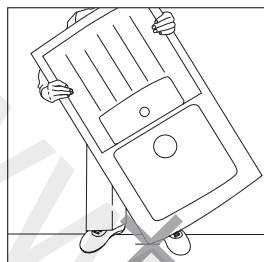



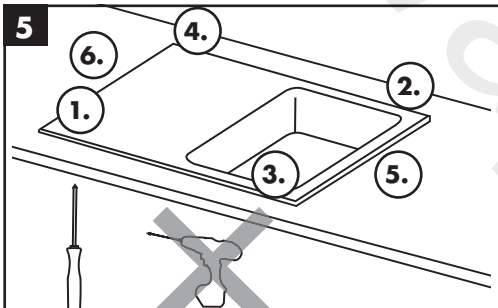
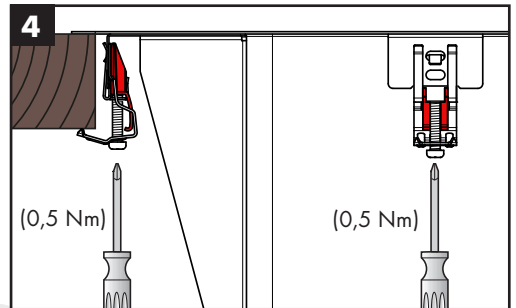
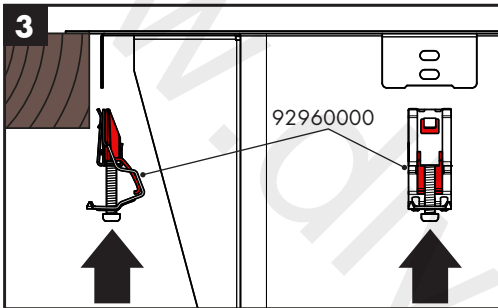
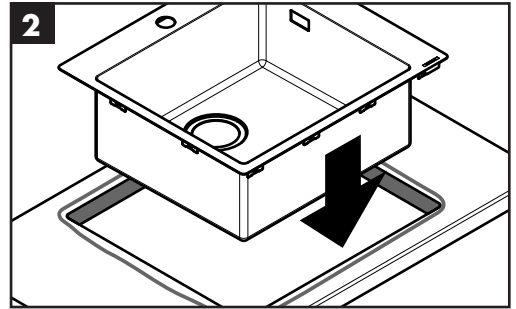
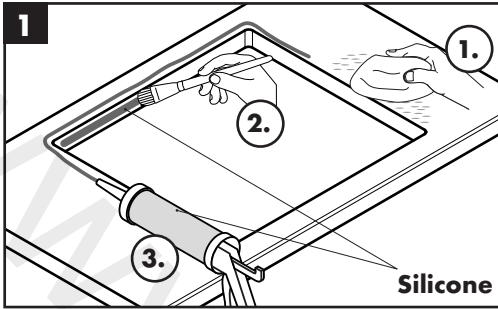









		L	B	R
C71-F450-06 43201XXX C71-F450-01 43207XXX S711-F450 43301800 S712-F450 43305800		530	480	0 - 10
C71-F660-08 43202XXX C71-F660-03 43209XXX S711-F660 43302800 S712-F660 43308800		740	480	0 - 10
C71-F765-10 43203XXX C71-F765-05 43211XXX S711-F765 43303800 S712-F765 43311800		845	480	0 - 10
C71-F655-09 43206XXX C71-F655-04 43210XXX S711-F655 43309800 S712-F655 43310800		735	480	0 - 10
C71-F450-07 43205XXX C71-F450-02 43208XXX S715-F450 43306800 S717-F450 43307800		1025	490	0 - 10
C71-F450-11 43229XXX C71-F450-12 43230XXX S716-F450 43331800 S718-F450 43332800		1025	490	0 - 10





		L ¹	L ²	B ¹	B ²	R
C71-F450-06 43201XXX C71-F450-01 43207XXX S711-F450 43301800 S712-F450 43305800		530	552	480	502	11
C71-F660-08 43202XXX C71-F660-03 43209XXX S711-F660 43302800 S712-F660 43308800		740	762	480	502	11
C71-F765-10 43203XXX C71-F765-05 43211XXX S711-F765 43303800 S712-F765 43311800		845	867	480	502	11
C71-F655-09 43206XXX C71-F655-04 43210XXX S711-F655 43309800 S712-F655 43310800		735	757	480	502	11
C71-F450-07 43205XXX C71-F450-02 43208XXX S715-F450 43306800 S717-F450 43307800		1025	1047	490	512	11
C71-F450-11 43229XXX C71-F450-12 43230XXX S716-F450 43331800 S718-F450 43332800		1025	1047	490	512	11
S719-U400 43425800		430	452	430	452	11
S719-U450 43426800		480	502	430	452	11
S719-U500 43427800		530	552	430	452	11
S719-U660 43428800		690	712	430	452	11
S719-U655 43429800		685	707	430	452	11
S719-U765 43430800		795	817	430	452	11

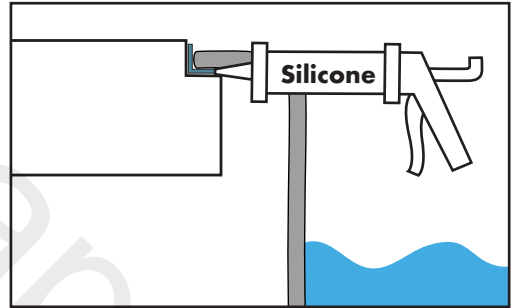
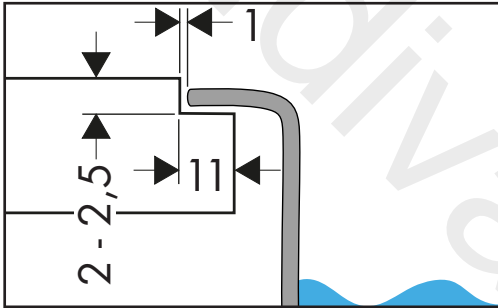
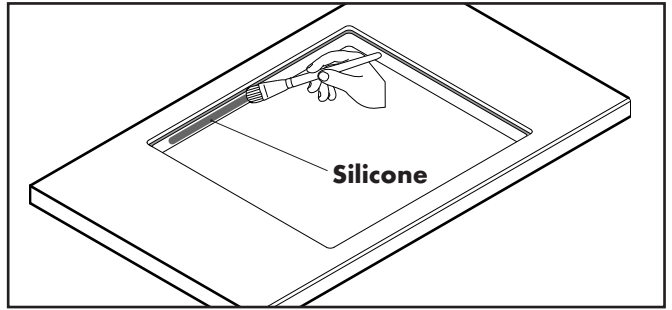
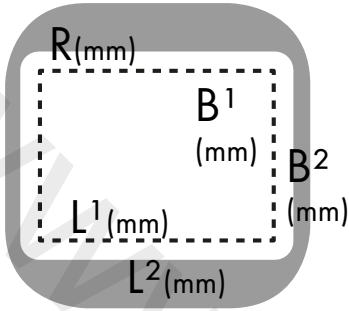



- DE** Reinigungsempfehlung / Garantie / Kontakt
- FR** Recommandation pour le nettoyage / Garanties / Contact
- EN** Cleaning recommendation / Warranty / Contact
- IT** Raccomandazione di pulizia / Garanzia / Contatto
- ES** Recomendaciones para la limpieza / Garantía / Contacto
- NL** Aanbevelingen inzake reiniging / Garantie / Contact
- DK** Rengøringsvejledning / Garanti / Kontakt
- PT** Recomendações de limpeza / Garantia / Contacto
- PL** Zalecenie dotyczące pielęgnacji / Gwarancja / Kontakt
- CS** Doporučení k čištění / Záruka / Kontakt
- SK** Odporúčania pre čistenie / Záruka / Kontakt
- ZH** 清洁指南 / 担保 / 接触
- RU** Рекомендации по очистке / Гарантия / Контакты
- FI** Puhdistussuositus / Takuu / Kosketus
- SV** Rengöringsrekommendationer / Garanti / Contacto
- LT** Valymo rekomendacijos / Garantija / Kontaktai
- HR** Preporuke za čišćenje / Garancija / Kontakt
- TR** Temizleme önerisi / Garanti / Temas
- RO** Recomandări pentru curățare / Garanție / Contact
- EL** Σύσταση καθαρισμού / Εγγύηση / επαφή
- SL** Priporočilo za čiščenje / Garancija / Kontakt
- ET** Puhastussuositused / Garantii / Kontakt
- LV** Tīrīšanas ieteikumi / Garantija / Kontakti
- SR** Preporuke za čišćenje / Garancija / Kontakt
- NO** Anbefaling for rengjøring / Garanti / Kontakt
- BG** Препоръка за почистване / Гаранция / Контакт
- SQ** Këshilla rreth pastrimit / Garancia / Kontakt
- KO** 세정시 권장사항 / 품질보증 / 접촉
- AR** توصيات التنظيف / الضمان / اتصال
- HU** Tisztítási tanácsok / Garancia / érintkezés
- JP** お手入れの方法 / 保証について / ご連絡先



[www.hansgrohe.com/
cleaning-recommendation](http://www.hansgrohe.com/cleaning-recommendation)

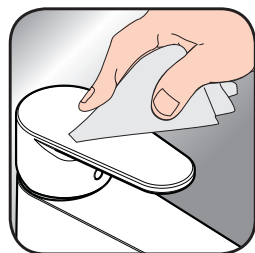

[www.hansgrohe.com/
cleaning-recommendation](http://www.hansgrohe.com/cleaning-recommendation)



[www.hansgrohe.com/
cleaning-recommendation](http://www.hansgrohe.com/cleaning-recommendation)



[www.hansgrohe.com/
cleaning-recommendation](http://www.hansgrohe.com/cleaning-recommendation)

www.divapor.com



43201XXX	X	
43202XXX	X	
43203XXX	X	
43205XXX	X	
43206XXX	X	
43207XXX	X	
43208XXX	X	
43209XXX	X	X
43210XXX	X	X
43211XXX	X	X
43229XXX	X	
43230XXX	X	