

# AXOR

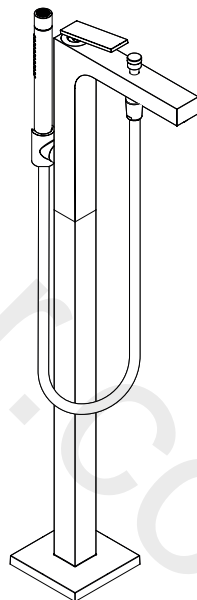

EN Installation / User Instructions / Warranty  
FR Instructions de montage / Mode d'emploi / Garantie  
ES Instrucciones de montaje / Manejo / Garantía

AXOR Citerio  
39440XX1  
39471XX1

## INSTALLATION

# ENGLISH

## TECHNICAL INFORMATION

Water pressure	
Recommended	15 - 75 PSI (0.1 - 0.5 MPa)
Maximum	145 PSI (1 MPa)
Hot water temp.	
Recommended	120°-140° F (48° - 60° C)*
Maximum	158°F (70° C)*
Flow rate	
tub filler	5.8 GPM (22 L/min) @ 44 PSI
handshower	max. 1.75 GPM (6.6 L/min)

\* Please know and follow all applicable local plumbing codes when setting the temperature on the water heater.

## INSTALLATION CONSIDERATIONS

- / For best results, Hansgrohe recommends that this unit be installed by a licensed, professional plumber.
- / This showerhead is for use with an automatically compensating valve rated at 1.3 GPM (4.9 L/min) or less.
- / Please read over these instructions thoroughly before beginning installation. Make sure that you have all tools and supplies needed to complete the installation.
- / To prevent scald injury, the maximum output temperature of the shower mixing valve must be no higher than 120°F (49°C). In Massachusetts, the maximum output temperature can be no higher than 112°F (44°C).
- ⚠ This trim is for use with rough valve 10452181 (not included).
- / Keep this booklet and the receipt (or other proof of date and place of purchase) for this product in a safe place. The receipt is required should it be necessary to request warranty parts.
- / This unit is not anti-scald. In Massachusetts, or if required by local plumbing code, install an approved water temperature limiting device conforming to ASSE 1070 (not available from Hansgrohe).
- / Protection against backflow is provided by a check valve and by an automatically resetting diverter.

# FRANÇAIS

## DONNÉES TECHNIQUES

Pression d'eau	
recommandée	15 - 75 PSI (0.1 - 0.5 MPa)
maximum	145 PSI (1 MPa)
Température d'eau chaude	
recommandée	120°-140° F (48° - 60° C)*
maximum	158°F (70° C)*
Capacité nominale	
bec	5.8 GPM (22 L/min)
douchette	1.75 GPM (6.6 L/min) max.

\* Vous devez connaître et respecter tous les codes de plomberie locaux applicables pour le réglage de la température du chauffe-eau.

## À PRENDRE EN CONSIDÉRATION POUR L'INSTALLATION

- / Pour de meilleurs résultats, Hansgrohe recommande que ce produit soit installé par un plombier professionnel licencié.
- / Veuillez lire attentivement ces instructions avant de procéder à l'installation. Assurez-vous de disposer de tous les outils et du matériel nécessaires pour l'installation.
- ⚠ Ce dispositif requiert une pièce intérieure 10452181 (non comprise).
- / Ce produit ne possède pas de dispositif anti-brûlure. Au Massachusetts, ou si le code de plomberie local l'exige, installez un limiteur de température de l'eau conforme à la norme ASSE 1070 (non disponible auprès de Hansgrohe).
- / La protection contre le retour d'eau est assurée par un clapet de non-retour et un dispositif de dérivation à réenclenchement automatique.
- / Cette pomme de douche est à utiliser avec des valves de compensation automatiques ayant un débit de 1.3 GPM (4.9 L/min) ou inférieur.
- / Pour empêcher des blessures par ébullition, la température de sortie maximale du robinet de douche ne doit pas excéder 120°F (49°C). Au Massachusetts, la température de sortie maximale du robinet de douche ne doit pas excéder 112°F (44°C).
- / Conservez ce livret et le reçu (ou une autre preuve sur laquelle figurent la date et l'endroit de l'achat) pour ce produit dans un endroit sûr. Le reçu est requis si vous commandez des pièces sous garantie.

## DATOS TECNICOS

Presión en servicio	
recomendada	15 - 75 PSI (0.1 - 0.5 MPa)
max.	145 PSI (1 MPa)
Temperatura del agua caliente	
recomendada	120°-140° F (48° - 60° C)*
max.	158°F (70° C)*
Caudal	
surtidor	5.8 GPM (22 L/min)
teleducha	1.75 GPM (6.6 L/min) max.

\* Debe conocer y cumplir todos los códigos locales aplicables para ajustar la temperatura del calentador de agua.

## CONSIDERACIONES PARA LA INSTALACIÓN

- / Para obtener mejores resultados, la instalación debe estar a cargo de un plomero profesional matriculado.
- / Este cabezal de ducha está diseñado para uso con válvulas de compensación automáticas calificado a 1.3 GPM (4.9 L/min) o menos.
- / Antes de comenzar la instalación, lea estas instrucciones detenidamente. Asegúrese de tener las herramientas y los insumos necesarios para completar la instalación.
- / Para evitar escaldaduras, la máxima temperatura de salida de la válvula de la ducha no debe exceder los 120°F (49°C). En Massachusetts, la máxima temperatura de salida de la válvula de la ducha no debe exceder los 112°F (44°C).
- ⚠ La unidad requiere una pieza interior de válvula 10452181 (no incluida).
- / Mantenga este folleto y el recibo (u otro comprobante del lugar y fecha de compra) de este producto en lugar seguro. El recibo se requiere en caso de ser necesario solicitar piezas bajo garantía.
- / Esta unidad no es anti-escaldadura. En Massachusetts, o si así lo requiere el código de plomería local, instale un dispositivo de limitación de la temperatura del agua conforme a la norma ASSE 1070 (no disponible en Hansgrohe).
- / Una válvula de retención y un distribuidor que se reajusta automáticamente brindan protección contra el contraflujo.

AXOR Citterio  
39440XX1  
39471XX1

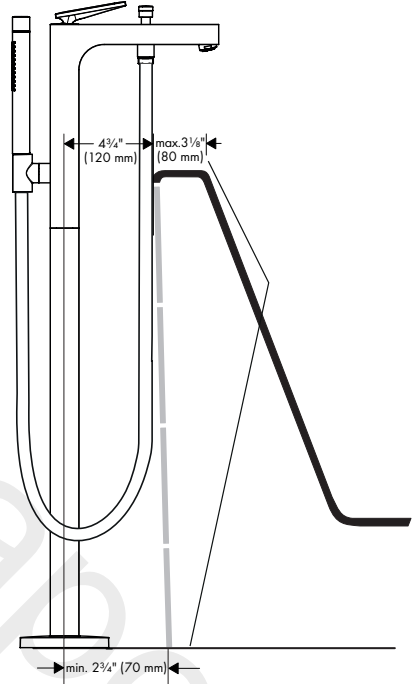
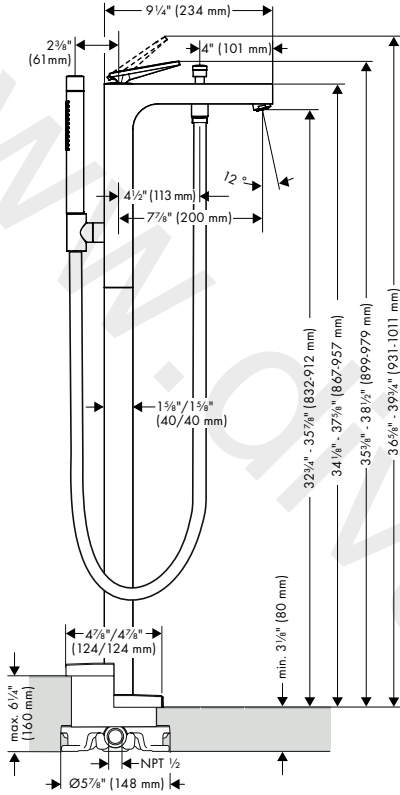

TOOLS REQUIRED / OUTILS REQUIS /  
HERRAMIENTAS ÚTILES

AXOR Starck  
04486000 - 1.75 GPM (6.6 l/min)

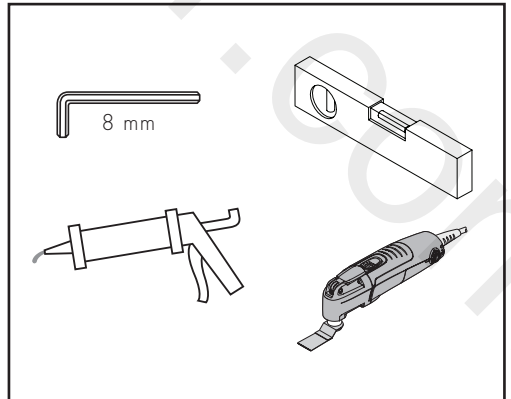
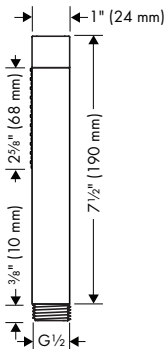

# EXTENSION / EXTENSIÓN 93882000

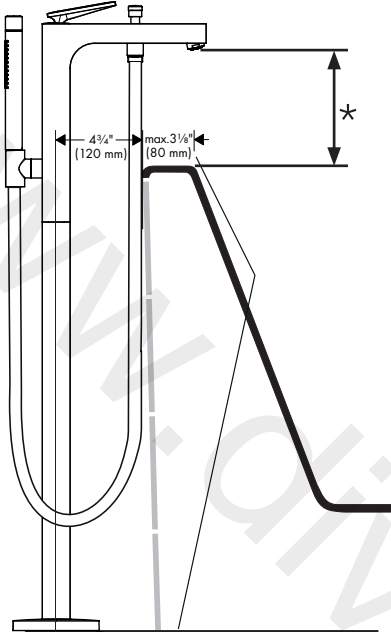

If measurement \* is less than the air gap required in your area, install this item with extension 93882000 (sold separately).

⚠ Extension 93882000 is intended for use when the rough is installed too deep in the floor.

If it is used to increase the height of the tub filler with a properly installed rough, unfinished parts will be visible.

Si la medida \* es inferior al espacio de aire requerido en su área, instale la extensión 93882000 (se vende por separado).

⚠ L'extension 93882000 est conçue pour être utilisée lorsque la pièce de surface est installée trop profondément dans le plancher.

Si elle est utilisée pour augmenter la hauteur d'un robinet de baignoire dont la pièce de surface est installée correctement, des pièces non finies seront visibles.

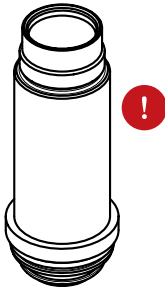

Si la medida \* es inferior al espacio de aire requerido en su área, instale la extensión 93882000 (se vende por separado).

⚠ La extensión 93882000 está diseñada para ser utilizada cuando la pieza interior se instala a demasiada profundidad en el piso.

Si se utiliza para aumentar la altura de un grifo de la bañera con una pieza interior instalada de forma adecuada, se podrán ver las piezas no terminadas.

# INSTALLATION / INSTALLATION / INSTALACIÓN

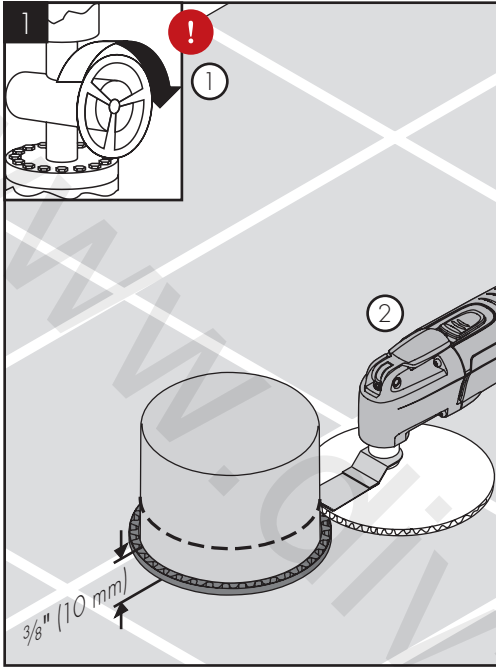

⚠ Turn the water off at the main before beginning!

Cut the plaster shield so that it extends  $\frac{3}{8}$ " above the surface of the finished floor.

⚠ Avant de commencer, fermez l'eau à la valve principale!

Coupez le protecteur de façon à ce qu'une partie de  $\frac{3}{8}$  po soit au-dessus de la surface du plancher fini.

⚠ ¡Cierre el paso del agua en la entrada del suministro antes de comenzar!

Corte el protector de yeso de modo que sobresalga  $\frac{3}{8}$ " de la superficie del acabado del piso.

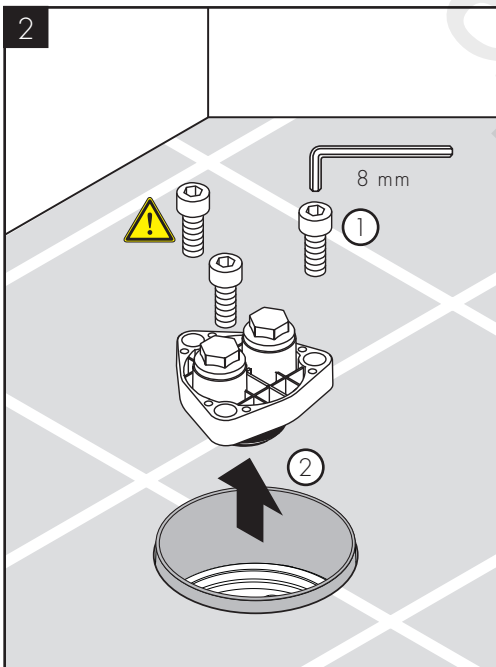

Remove the flush housing screws.

⚠ Do not discard the screws!

Remove the flush housing.

Retirez les vis du compartiment affleurant.

⚠ Ne jetez pas les vis!

Retirez le compartiment affleurant.

Retire los tornillos del alojamiento de descarga.

⚠ ¡No deseche los tornillos!

Retire el alojamiento de descarga.

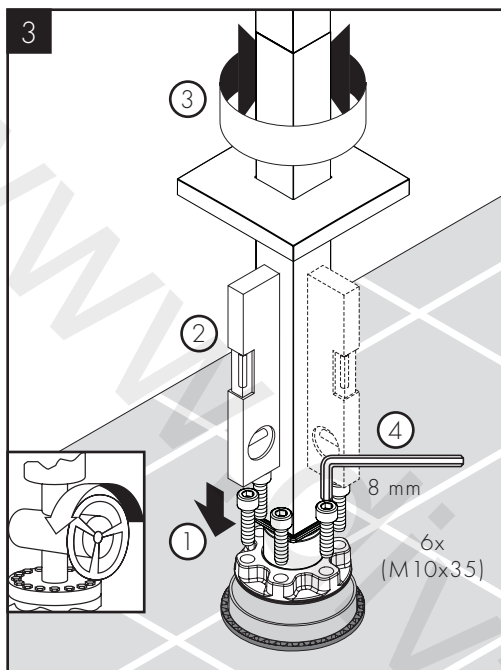

Position the tub filler on the rough.

Make sure that the tub filler is level.

Install the 6 screws (the 3 reserved screws from the flush housing plus the 3 included with the tub filler).

Placez le robinet de baignoire sur la pièce de surface.

Assurez-vous que le robinet de baignoire est de niveau.

Installez les 6 vis (les 3 vis retirées du compartiment affleurant et les 3 vis fournies avec le robinet de baignoire).

Coloque el grifo de la bañera en la pieza interior.

Asegúrese de que el grifo de la bañera quede nivelado.

Instale los 6 tornillos (los 3 tornillos reservados del alojamiento de descarga y los 3 incluidos con el grifo de la bañera).

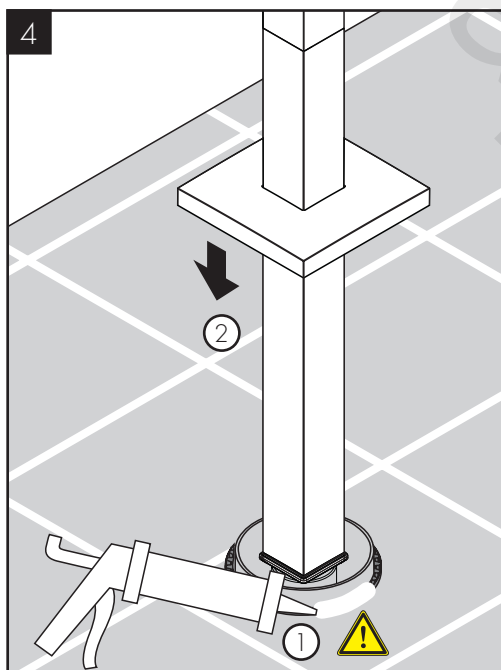

⚠ Seal the floor around the plaster shield with waterproof sealant .

Failure to seal the floor can lead to possible water damage.

Lower the escutcheon to the floor.

⚠ Scellez le plancher autour du protecteur à l'aide d'un agent d'étanchéité .

Si le plancher n'est pas scellé, l'eau pourrait éventuellement causer des dommages.

Abaissez l'écusson au sol.

⚠ Selle el piso alrededor del protector de yeso con un sellador impermeable.

Si no se sella el piso, pueden producirse daños por acción del agua.

Baje el escudo al piso.

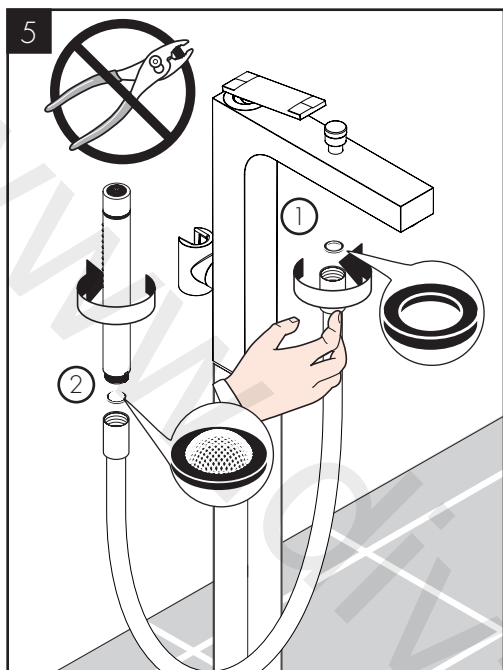

Place the black rubber washer in one end of the hose. Attach this end to the tub filler .

Place the screen washer in the other end of the hose. Attach this end to the handshower .

Rest the hand shower in the holder.

Placez la rondelle en caoutchouc noir dans l'une des extrémités du tuyau. Fixez cette extrémité au robinet de baignoire .

Placez le tamis dans l'autre extrémité du tuyau. Fixez cette extrémité à la douchette .

Déposez la douchette dans son support.

Coloque la arandela de goma negra en un extremo de la manguera. Acople este extremo al grifo de la bañera.

Coloque la arandela de filtro en el otro extremo de la manguera. Acople este extremo a la ducha de mano.

Apoye la ducha de mano en el soporte.

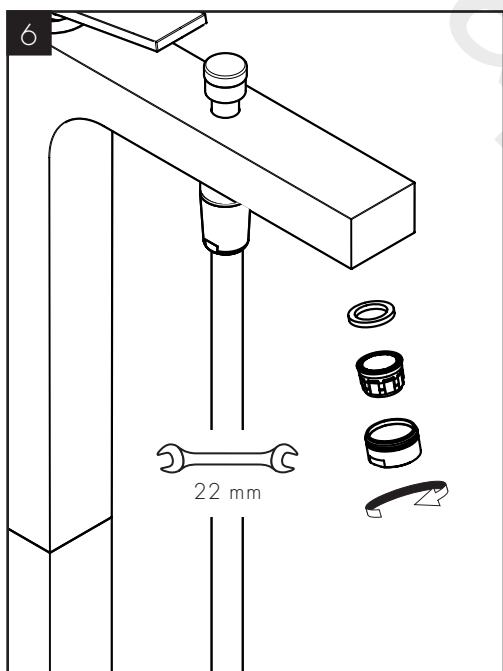

Remove the aerator.

Retirez l'aérateur.

Retire el aireador.

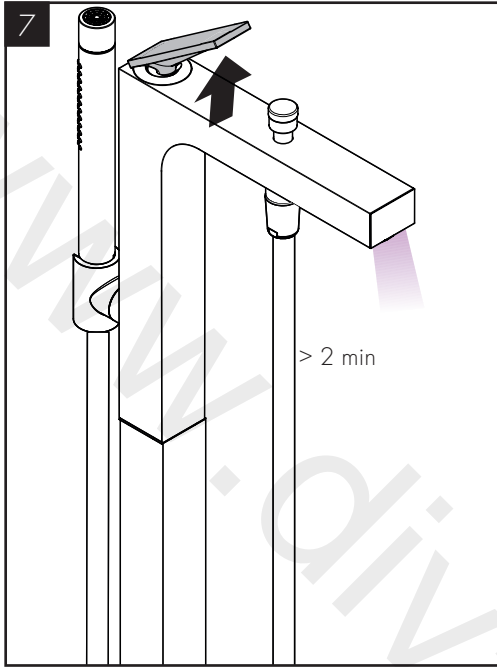

Flush the hot and cold supply lines for at least two minutes.

---

Rincez les conduites d'alimentation d'eau chaude et d'eau froide pendant au moins deux minutes.

---

Purgue los suministros de agua caliente y agua fría durante al menos dos minutos.

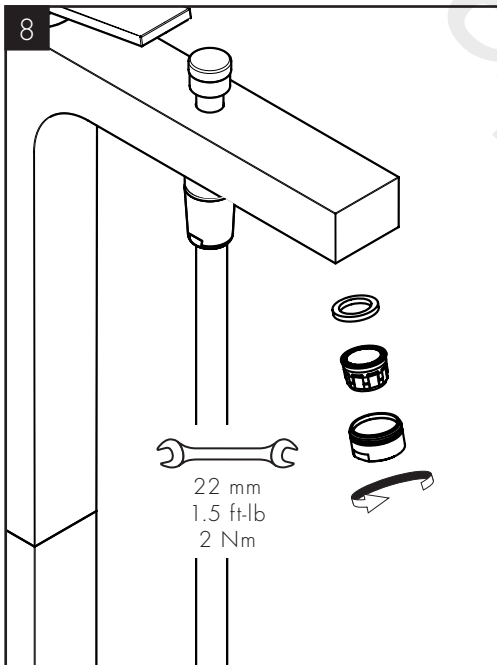

Install the aerator.

---

Installez l'aérateur.

---

Instale el aireador.

SET HOT WATER LIMITER / POSITIONNER LE LIMITEUR DE TEMPÉRATURE / AJUSTAR TOPE

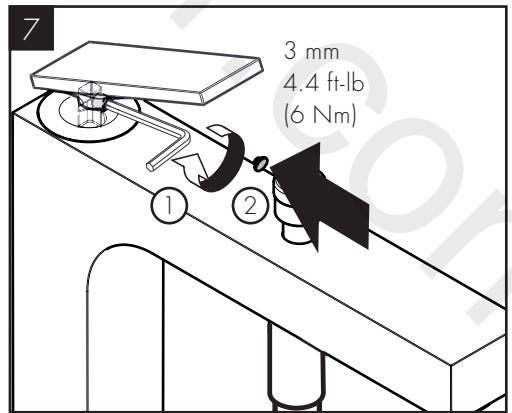
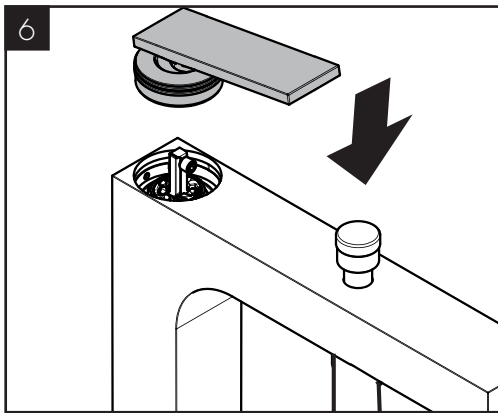
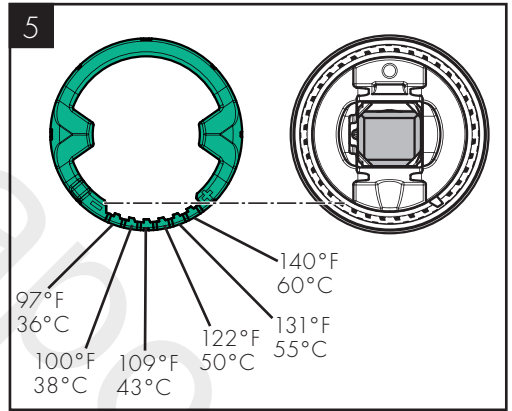
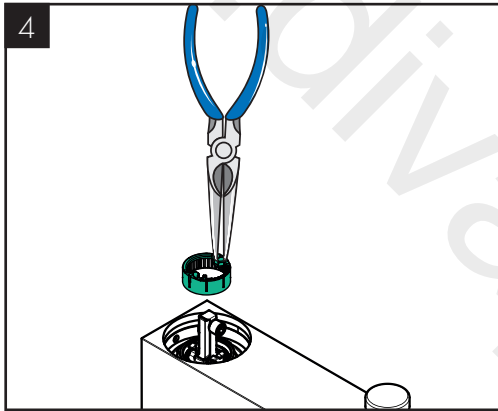
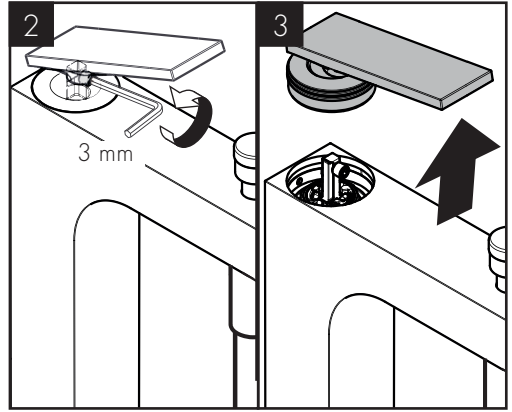
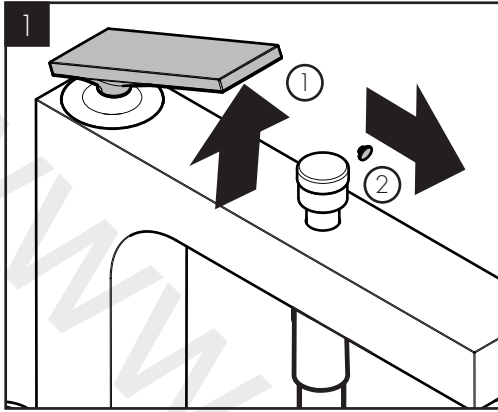

REPLACEMENT PARTS / PIÈCES DÉTACHÉES / REPUESTOS

AXOR Citterio  
39440XX1  
39471XX1

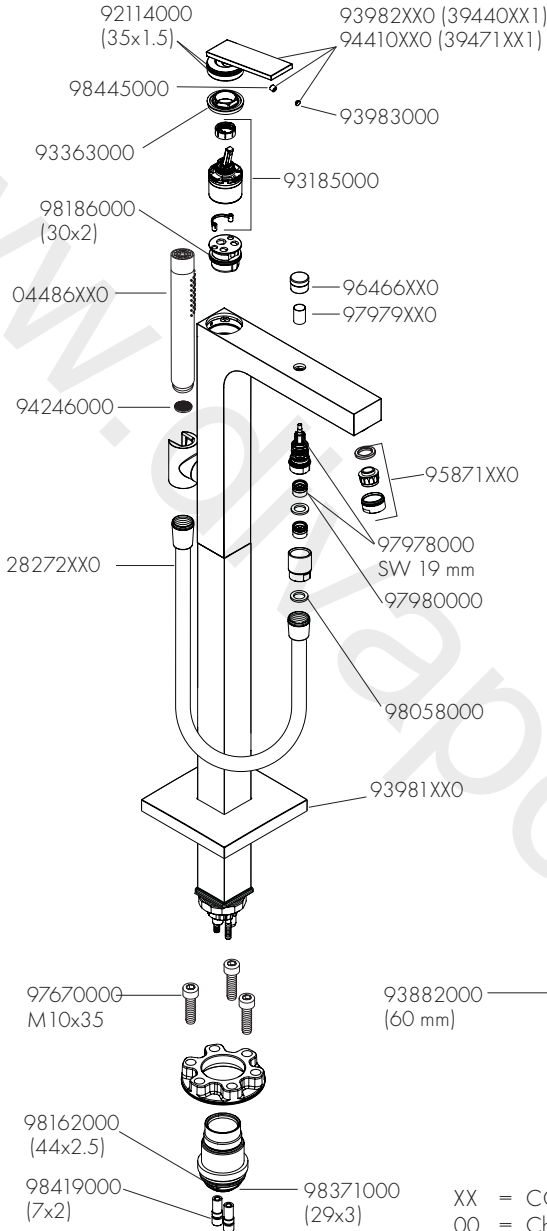

XX = COLORS / COULEURS / ACABADOS  
00 = Chrome  
25 = Brushed Gold Optik  
34 = Brushed Black Chrome  
82 = Brushed Nickel

USER INSTRUCTIONS / INSTRUCTIONS DE SERVICE / MANEJO

on  
ouvert  
abierto

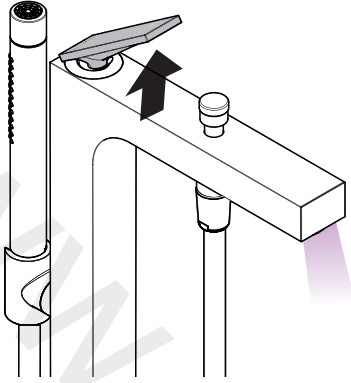

off  
fermé  
cerrado

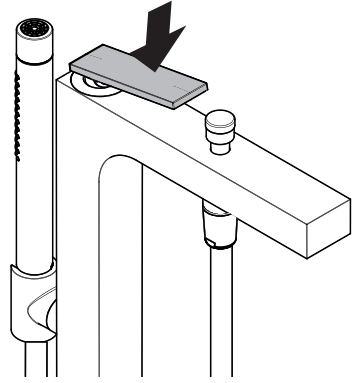

hot  
chaud  
caliente

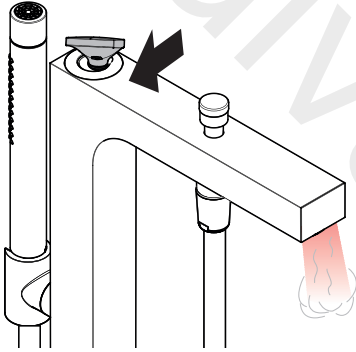

cold  
froid  
frío

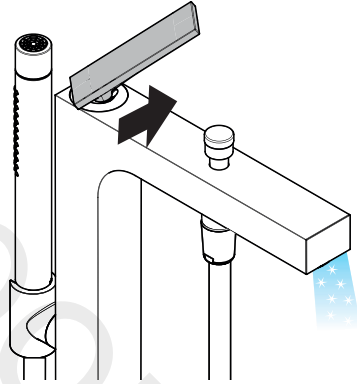

on  
ouvert  
abierto

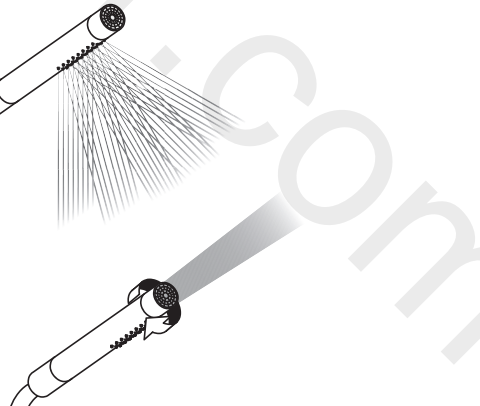
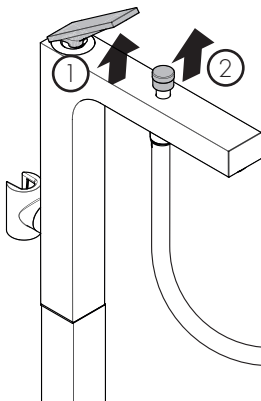

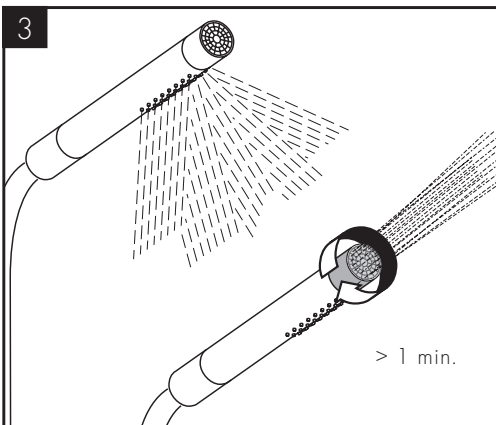
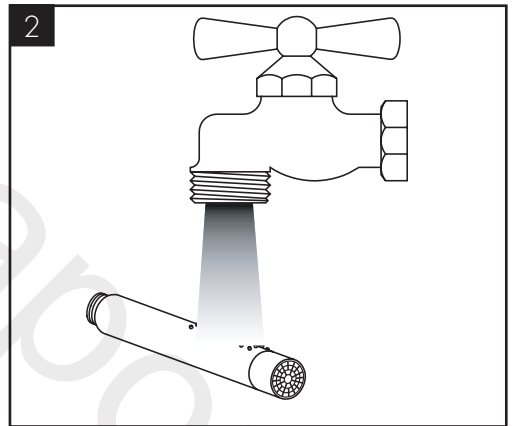
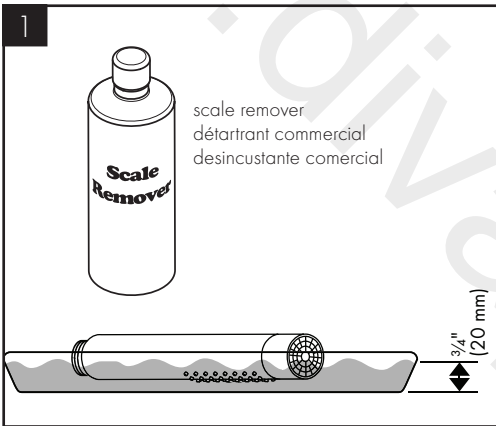
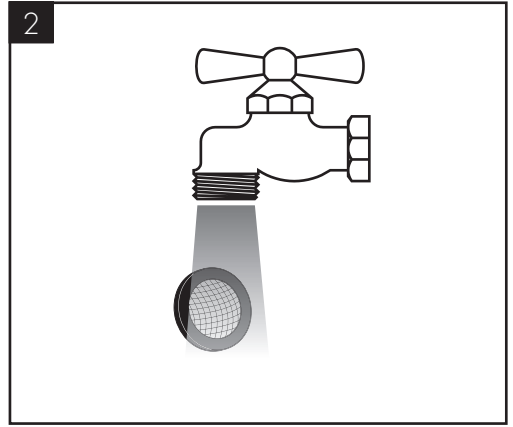
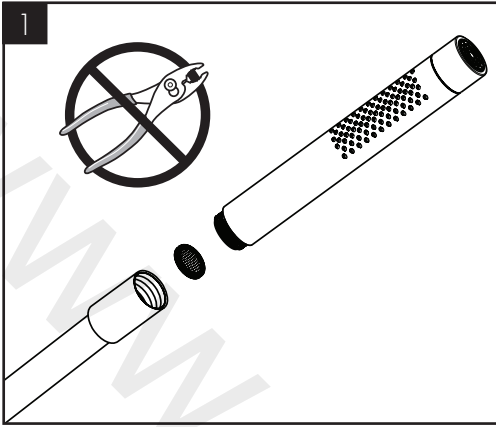

CHECK VALVE MAINTENANCE / ENTRETIEN DE LES CLAPETS ANTI-RETOUR /  
MANTENIMIENTO DE LAS VÁLVULAS ANTIRRETORNOS

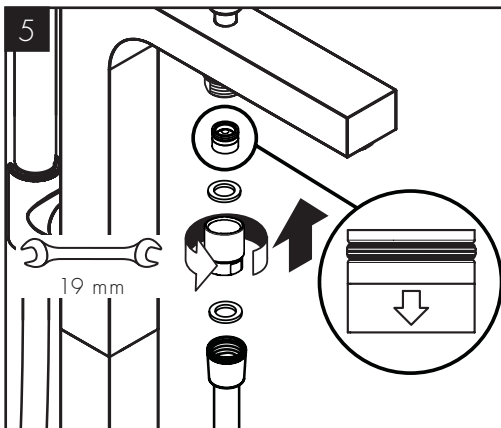
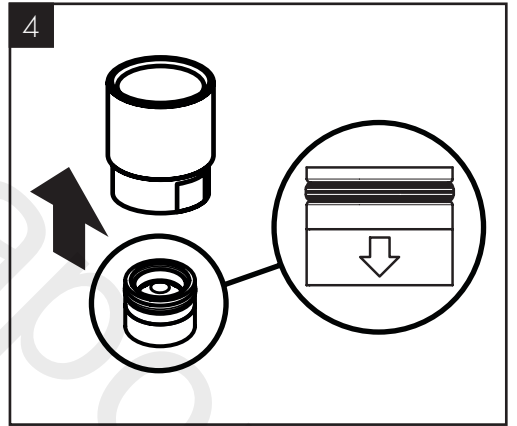
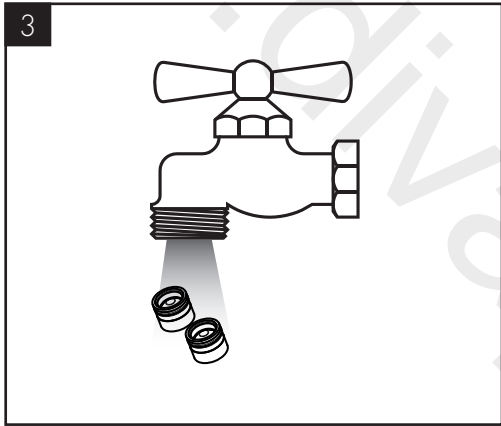
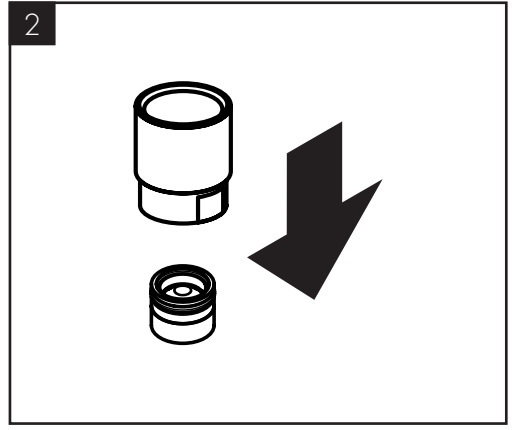
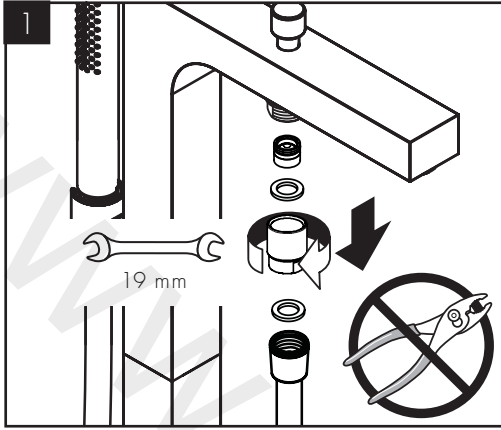

HOT AND COLD SUPPLIES ARE REVERSED / LES RACCORDS D'EAU CHAUDE ET D'EAU FROIDE ONT ÉTÉ INTERVERTIS / LAS CONEXIONES DE AGUA CALIENTE Y FRÍA ESTÁN CAMBIADAS

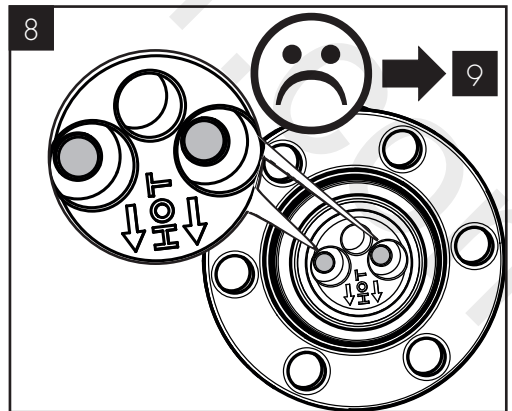
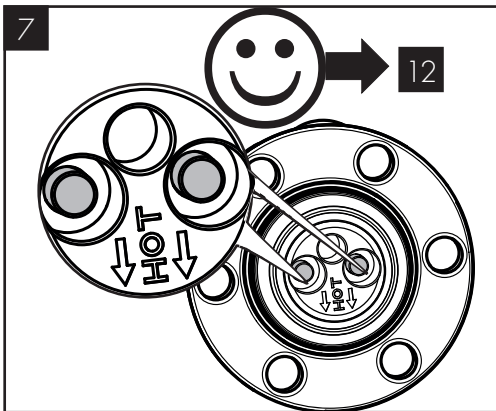
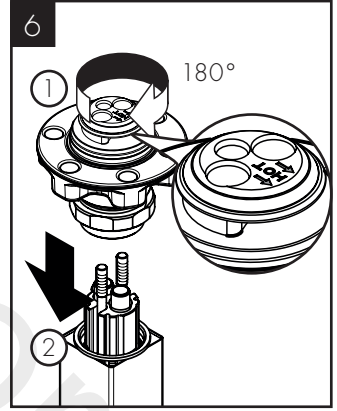
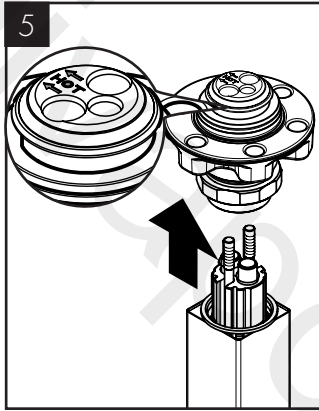
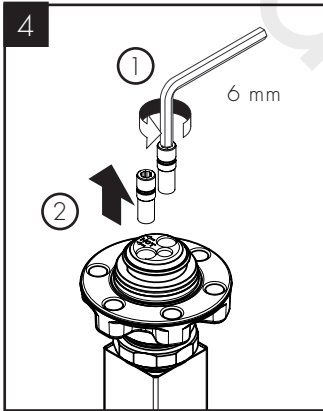
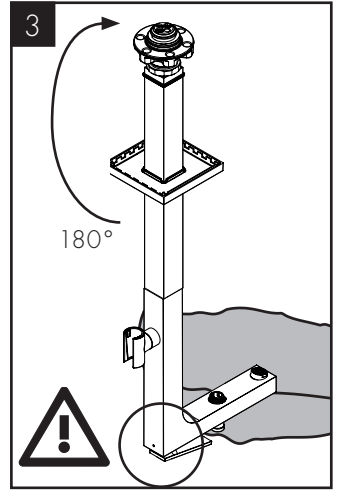
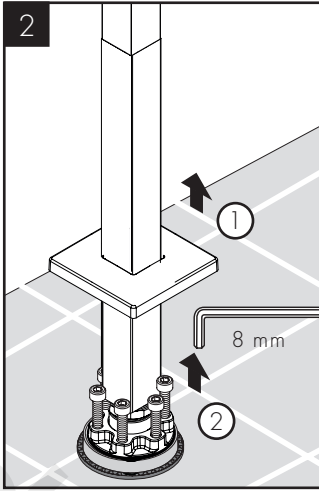
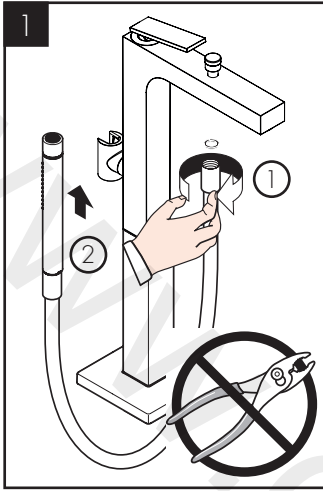

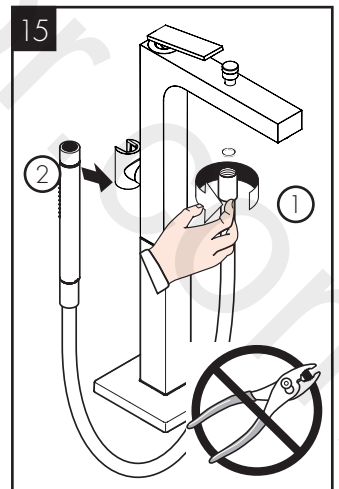
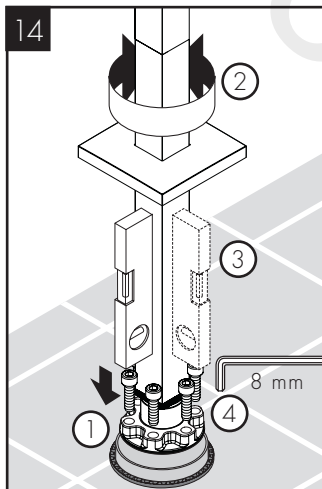
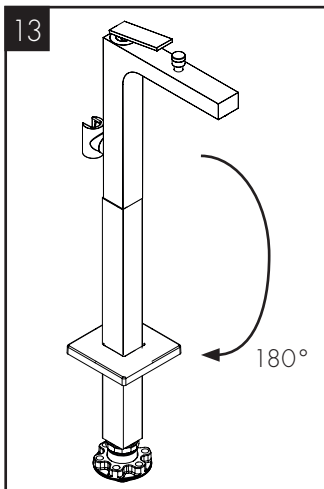
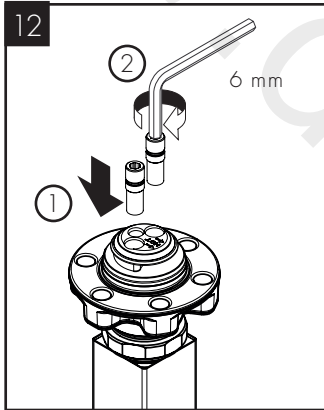
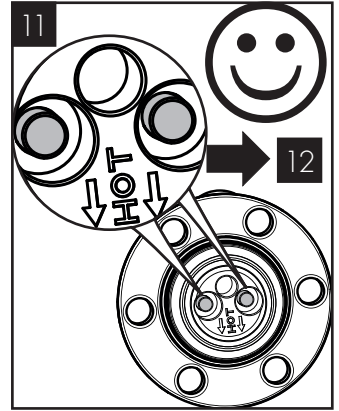
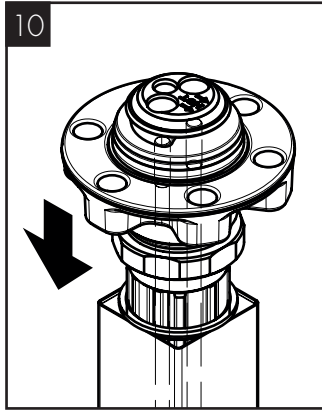
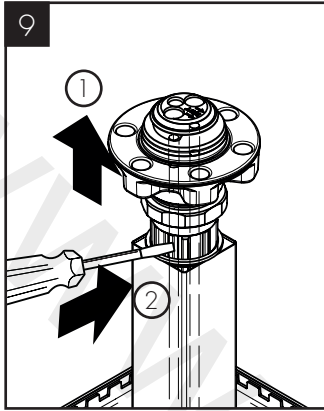

# CLEANING RECOMMENDATION FOR HANSGROHE PRODUCTS

Modern bathroom faucets, kitchen faucets and shower products are made from different materials to comply with the needs of the market with regard to design and functionality. To avoid damage to the product, it is necessary to take proper care of it.

## FOR BEST RESULTS:

- / Prevent the buildup of mineral scale and /or soap residue by cleaning your Hansgrohe product(s) when needed.
- / Select a cleaning agent specifically intended for the type of product.
- / DO NOT use these types of cleaners as they will cause damage to your Hansgrohe product:
  - Any cleaning agent containing hydrochloric acid, formic acid, lye, or acetic acid.
  - Abrasive cleaning powders, pads, or brushes.
  - Steam cleaners.
  - "No rinse" cleaning agents.
- / ALWAYS follow the instructions provided by the manufacturer of the cleaning agent.
- / DO NOT mix cleaning agents, unless directed by the manufacturer.
- / DO NOT spray cleaners directly onto the product as drops could enter openings and gaps and cause damage. When using spray cleaners, spray the cleaner onto a soft cloth or sponge.
- / ALWAYS rinse your Hansgrohe product thoroughly with clear water and polish dry with a soft cloth after cleaning.

## IMPORTANT

- / Residue from soaps and shampoos can cause damage. Rinse the product with clean water after each use.
- / Residue from basin/tub/tile cleaner can cause damage to faucets and fittings. Immediately rinse any overspray from the Hansgrohe product.
- / DO NOT store any cleaning agents under your Hansgrohe product, such as in a vanity unit, as the fumes may damage the product.
- / DAMAGE TO THE PRODUCT CAUSED BY IMPROPER CARE OR THE USE OF IMPROPER CLEANING AGENTS IS NOT COVERED BY THE WARRANTY.
- / IF A COMPONENT OF THE PRODUCT IS DAMAGED, REPLACE IT, AS THERE IS RISK OF INJURY.

# CONSEIL DE NETTOYAGE POUR LES PRODUITS HANSGROHE

Les robinets pour les salles de bains et les cuisines modernes ainsi que les produits récents pour les douches se composent de matériaux différents afin de satisfaire aux besoins du marché en termes de conception et de fonctionnalité. Afin d'éviter d'endommager le produit, il est nécessaire d'en prendre soin.

## POUR DE MEILLEURS RÉSULTATS :

- / Empêchez l'accumulation de tarte et/ou de résidu de savon en nettoyant votre produit Hansgrohe lorsque c'est nécessaire.
- / Sélectionnez un produit de nettoyage spécifiquement prévu pour ce type de produit.
- / N'UTILISEZ PAS ces types de nettoyeurs car ils peuvent endommager votre produit Hansgrohe :
  - Tout produit de nettoyage contenant de l'acide chlorhydrique, de l'acide formique, de la potasse ou de l'acide acétique.
  - Les poudres de nettoyage, les tampons ou les brosses abrasives.
  - Les nettoyeurs à vapeur.
  - Les produits de nettoyage « sans rinçage ».
- / NE MÉLANGEZ PAS les produits de nettoyage, à moins que cela soit indiqué par le fabricant.
- / NE PULVÉRISEZ PAS les nettoyeurs directement sur le produit car des gouttes pourraient entrer dans les ouvertures et les fentes et causer des dommages. Lorsque vous utilisez des nettoyeurs par pulvérisation, pulvérisez le nettoyeur sur un chiffon ou une éponge douce.
- / Après le nettoyage rincer abondamment à l'eau claire pour éliminer intégralement les restes de détergent.

## IMPORTANT

- / Les residus de produits pour le corps comme les savons liquides, shampooings, gels de douche, teintures pour cheveux, parfums, apres-rasage et vernis à ongles peuvent causer des deteriorations. Rincez le produit avec de l'eau propre après chaque utilisation.
- / Le résidu provenant des nettoyeurs pour cuvette/baignoire/carrelage peut endommager les robinets et les raccords de tuyauterie. Rincez immédiatement toute surpulvérisation sur le produit Hansgrohe.
- / De meme, il est interdit de stocker des detergents ou des produits chimiques sous les produits, par ex. dans un meuble sous lavabo, car les vapeurs qui s'en degagent risquent d'abimer les produits.
- / LES DOMMAGES AU PRODUIT CAUSÉS PAR UN MAUVAIS ENTRETIEN OU PAR L'UTILISATION DE PRODUITS DE NETTOYAGE INADÉQUATS NE SONT PAS COUVERTS PAR LA GARANTIE.
- / SI UN COMPOSANT DU PRODUIT EST ENDOMMAGÉ, REMPLACEZ-LE, CAR IL EXISTE UN RISQUE DE BLESSURE.

## RECOMENDACIÓN DE LIMPIEZA PARA LOS PRODUCTOS DE HANSGROHE

Hoy en día, las griferías de baño y de cocina así como duchas modernas se componen de materiales muy distintos para satisfacer las exigencias del mercado respecto al diseño y la funcionalidad. Para evitar daños y reclamaciones hay que tener en cuenta ciertos aspectos tanto en el uso como en su limpieza.

### PARA OBTENER MEJORES RESULTADOS:

- / Evite la acumulación de restos de jabón o sarro limpiando el producto Hansgrohe cuando sea necesario.
- / Seleccione un agente de limpieza diseñado específicamente para el tipo de producto.
- / NO use estos tipos de limpiadores, ya que causarán daño a su producto Hansgrohe:
  - Agentes limpiadores que contengan ácido clorhídrico, fórmico, acético o lejía.
  - Polvos, paños o cepillos de limpieza abrasivos.
  - Limpiadores a vapor
  - Agentes de limpieza "sin enjuague".
- / SIEMPRE siga las instrucciones provistas por el fabricante del agente de limpieza.
- / NO mezcle los agentes de limpieza, a menos que esté indicado por el fabricante.
- / NO rocíe limpiadores directamente sobre el producto, ya que podrían caer gotas sobre las aberturas y espacios y causar daños. Cuando use limpiadores en spray, rocíe el limpiador sobre un paño suave o esponja.
- / SIEMPRE enjuague su producto Hansgrohe con agua limpia y séquelo y lústrelo con un paño suave después de la limpieza.

## IMPORTANTE

- / Los residuos de productos de aseo como jabon liquido, champus, gel de ducha, tintes de pelo, perfumes, lociones de afeitado y esmalte de unas pueden danar tambien los materiales. Enjuague el producto con agua limpia después de cada uso.
- / Los residuos de limpiadores para lavatorios, bañeras o azulejos pueden causar daño a los grifos y accesorios. Enjuague inmediatamente cualquier derrame que haya sobre el producto de Hansgrohe.
- / Tampoco pueden generarse depositos de productos de limpieza o quimicos debajo de los productos, p. ej. En un armario de lavabo. De lo contrario, los vapores generados pueden danar los productos.
- / LOS DAÑOS QUE RESULTEN DE UN CUIDADO INADECUADO O USO DE AGENTES DE LIMPIEZA INADECUADOS NO ESTÁN CUBIERTOS POR LA GARANTÍA.
- / SI SE DAÑA UN COMPONENTE DEL PRODUCTO, REEMPLÁCELO, YA QUE EXISTE RIESGO DE LESIÓN.

# HANSGROHE, INC. LIMITED WARRANTY

Offering our customers the highest quality at all times is a fundamental part of the Hansgrohe, Inc. company philosophy. We offer consumers a limited warranty on our hansgrohe® and AXOR® branded products.

This warranty is limited to products manufactured by Hansgrohe, Inc. that are purchased from a Hansgrohe, Inc. authorized seller by a consumer in the United States or Canada after September 1, 2019, and installed in either the United States or in Canada.

## WARRANTY

Hansgrohe, Inc. warrants to the original consumer purchaser that hansgrohe and AXOR products will be free from defects in material and workmanship for as long as the original consumer purchaser owns both the product and the home in which the product was originally installed. For commercial purchasers, the warranty period is (a) one (1) year for hansgrohe products and (b) five (5) years for AXOR products, in each case from the date of purchase. The warranty period for products in the Rubbed Bronze, Matte Black and Matte White finishes are three (3) years from the date of purchase. This warranty is non-transferable.

## WHAT WE WILL DO

Hansgrohe, Inc., at its option, will replace any product or part of the product that proves defective in workmanship and/or material, under normal installation, use, service and maintenance. If Hansgrohe, Inc. is unable to provide a replacement part or product and repair is not practical or cannot be made in timely fashion, Hansgrohe, Inc. may elect to refund the purchase price in exchange for the return of the defective product. REPAIR OR REPLACEMENT (OR, IN LIMITED CIRCUMSTANCES, REFUND OF THE PURCHASE PRICE) AS PROVIDED UNDER THIS LIMITED WARRANTY IS THE EXCLUSIVE REMEDY OF THE PURCHASER.

## WHAT IS NOT COVERED BY THE WARRANTY

Because Hansgrohe, Inc. is unable to control the quality of hansgrohe or AXOR products sold by unauthorized sellers, unless otherwise prohibited by law, this warranty does not cover hansgrohe or AXOR products purchased from unauthorized sellers. Authorized sellers can be found on hansgrohe and AXOR branded websites.

Labor and other expenses for disconnection, deinstallation, or return of the product for warranty service (including but not limited to proper packaging and shipping costs), or for installation or reinstallation of the product are not covered by this warranty.

Hansgrohe, Inc. shall not be liable for any damage to the product resulting from

- reasonable wear and tear
- outdoor use
- misuse (including use of the product for an unintended application)
- freezing water
- excessive water pressure
- pipe corrosion in the home in which the product is installed
- abuse, neglect or improper or incorrectly performed installation, maintenance or repair, including the use of abrasive or caustic cleaning agents or "no-rinse" cleaning products.

This warranty does not cover: (i) accessories, connected materials and products, or related products not manufactured by Hansgrohe, Inc. (ii) any hansgrohe or AXOR product sold for display purposes or (iii) hansgrohe or AXOR products purchased from unauthorized sellers.

## WHAT YOU MUST DO TO OBTAIN WARRANTY SERVICE OR INFORMATION

Contact your retailer, or contact Technical Service at:

Hansgrohe, Inc.  
1492 Bluegrass Lakes Parkway  
Alpharetta, GA 30004  
Toll-free 800-334-0455

In requesting warranty service, you will need to provide:

1. The sales receipt or other evidence of the date and place of purchase.
2. A description of the problem.
3. Delivery of the product or the defective part, postage prepaid and carefully packed and insured, to:

Hansgrohe, Inc.  
1492 Bluegrass Lakes Parkway  
Alpharetta, GA 30004  
Toll-free 800-334-0455

When warranty service is completed, any repaired or replacement product or part will be returned to you postage prepaid.

REVISED SEPTEMBER 1, 2019.

**LIMITATION ON DURATION OF IMPLIED WARRANTIES:** Some States do not allow limitations on how long an implied warranty lasts, so the below limitations may not apply to you. TO THE MAXIMUM EXTENT PERMITTED BY APPLICABLE LAW, ANY IMPLIED WARRANTY, INCLUDING THE IMPLIED WARRANTIES OF MERCHANTABILITY AND OF FITNESS FOR A PARTICULAR PURPOSE, IS LIMITED TO THE STATUTORY PERIOD OR THE DURATION OF THIS WARRANTY, WHICHEVER IS SHORTER.

**LIMITATION OF SPECIAL, INCIDENTAL OR CONSEQUENTIAL DAMAGES:** Some States do not allow the exclusion or limitation of incidental or consequential damages, so the below limitations and exclusions may not apply to you. TO THE MAXIMUM EXTENT PERMITTED BY APPLICABLE LAW, THIS WARRANTY DOES NOT COVER, AND HANSGROHE, INC. SHALL NOT BE LIABLE FOR, ANY SPECIAL, INCIDENTAL OR CONSEQUENTIAL DAMAGES (INCLUDING LABOR CHARGES TO REPAIR, REPLACE, INSTALL OR REMOVE THIS PRODUCT), WHETHER ARISING OUT OF BREACH OF ANY EXPRESS OR IMPLIED WARRANTY, BREACH OF CONTRACT, TORT, OR OTHERWISE. HANSGROHE, INC. SHALL NOT BE LIABLE FOR ANY DAMAGE TO THE PRODUCT RESULTING FROM REASONABLE WEAR AND TEAR, OUTDOOR USE, MISUSE (INCLUDING USE OF THE PRODUCT FOR AN UNINTENDED APPLICATION), FREEZING WATER, EXCESSIVE WATER PRESSURE, PIPE CORROSION IN THE HOME IN WHICH THE PRODUCT IS INSTALLED, ABUSE, NEGLECT OR IMPROPER OR INCORRECTLY PERFORMED INSTALLATION, MAINTENANCE

OR REPAIR, INCLUDING THE USE OF ABRASIVE OR CAUSTIC CLEANING AGENTS OR "NO-RINSE" CLEANING PRODUCTS.

**NOTICE TO RESIDENTS OF THE STATE OF NEW JERSEY:**

The provisions of this warranty, including its limitations, are intended to apply to the fullest extent permitted by the laws of the State of New Jersey.

This warranty gives you specific legal rights, and you may also have other rights which vary from state to state.

**PRODUCT INSTRUCTIONS AND QUESTIONS**

Upon purchase or prior to installation, please carefully inspect your product for any damage or visible defect. Prior to installing, always carefully study the enclosed instructions on the proper installation and the care and maintenance of this product.

If you have questions at any time about the use, installation or performance of your product, or the Limited Warranty, please write us or call us toll-free at 800-334-0455.

[www.divapor.com](http://www.divapor.com)

[www.divapor.com](http://www.divapor.com)

# AXOR

www.divapor.com

AXOR / Hansgrohe, Inc.  
1490 Bluegrass Lakes Parkway  
Alpharetta, GA 30004  
Tel. 800-334-0455  
Fax 770-889-1783

[axor-design.com](http://axor-design.com)