

# Dornbracht Installation instructions

Montageanleitung  
Instructions de montage  
Instrucciones de montaje

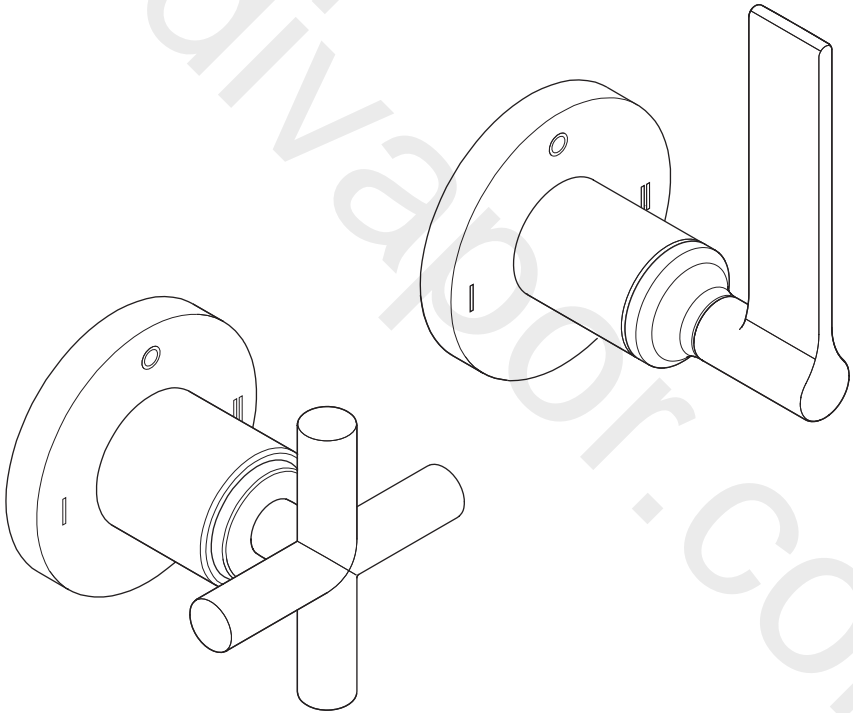

36 200 809-FF 0010 / 36 210 809-FF 0010 / 36 200 819-FF 0010 / 36 210 819-FF 0010  
36 200 882-FF 0010 / 36 210 882-FF 0010 / 36 200 892-FF 0010 / 36 210 892-FF 0010  
36 200 740-FF 0010 / 36 210 740-FF 0010

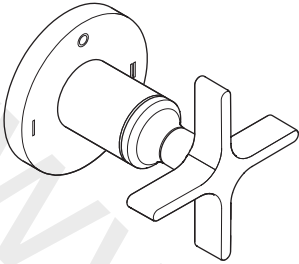

36 200 809-FF 0010 /  
36 210 809-FF 0010

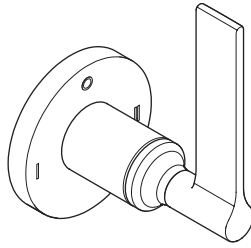

36 200 819-FF 0010 /  
36 210 819-FF 0010

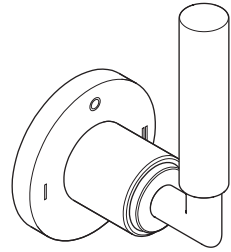

36 200 882-FF 0010 /  
36 210 882-FF 0010

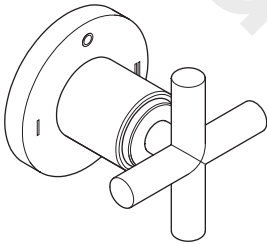

36 200 892-FF 0010 /  
36 210 892-FF 0010

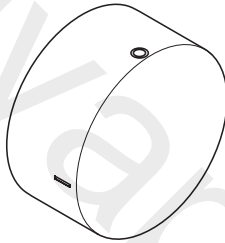

36 200 740-FF 0010 /  
36 210 740-FF 0010

Please read this manual and follow the instructions.

All manuals and documents belonging to the product have to be passed on to the end user. Otherwise the producer liability may be limited in case of damage.

All work has to be carried out by a competent and qualified plumber according national regulations and regulations of the local water supply companies.

Local accident prevention regulations are to be followed with priority.

Operating conditions and dimensions can be found in the appendix.

For questions or uncertainties regarding installation or operation, please contact the Technical Service of Dornbracht.

You can find relevant contact details on the back of this manual and on the website of Dornbracht: [www.dornbracht.com](http://www.dornbracht.com)

 **ATTENTION!**

This symbol warns of property damages due to non-compliance with the instructions.

 **NOTICE!**

This symbol calls attention to important information.

Bitte lesen Sie die Anleitung und beachten Sie die Hinweise.

Alle zum Produkt gehörenden Anleitungen und Dokumente sind an den Endbenutzer zu übergeben. Ansonsten kann die Haftung des Herstellers im Schadensfall eingeschränkt sein.

Sämtliche Sanitärarbeiten sind durch einen sachkundigen und qualifizierten Sanitärfachinstallateur gemäß den einschlägigen länderspezifischen Vorschriften und den Vorschriften der örtlichen Wasserversorgungsunternehmen auszuführen.

Örtliche Vorschriften zur Unfallverhütung sind vorrangig zu befolgen.

Betriebsbedingungen und Maße finden Sie im Anhang.

Bei Fragen oder Unsicherheiten bezüglich Montage oder Bedienung kontaktieren Sie bitte Dornbrachts Technischen Service.

Sie finden entsprechende Kontaktdaten auf der Rückseite dieser Anleitung und auf der Homepage von Dornbracht: [www.dornbracht.com](http://www.dornbracht.com)

 **ACHTUNG!**

Dieses Symbol warnt vor Sachschäden bei Nichtbeachten der Hinweise.

 **HINWEIS!**

Dieses Symbol macht auf wichtige Informationen aufmerksam.

Veillez lire les instructions et respecter les consignes.

Toutes les instructions et tous les documents fournis avec le produit doivent être remis à l'utilisateur final. Sinon, la responsabilité du fabricant peut être limitée en cas de sinistre.

Tous les travaux sanitaires doivent être effectués par un installateur sanitaire compétent et qualifié conformément aux spécifications aux prescriptions locales spécifiques et aux prescriptions des entreprises de distribution d'eau locales. Les prescriptions locales de prévention des accidents doivent être respectées en priorité. Vous trouverez les conditions de fonctionnement et les dimensions en annexe.

Pour toute question ou incertitude concernant le montage ou l'utilisation, veuillez contacter le service technique de Dornbracht.

Vous trouverez les coordonnées du service à contacter au verso de ces instructions et sur le site Internet de Dornbracht : [www.dornbracht.com](http://www.dornbracht.com)



### IMPORTANT !

Ce symbole met en garde contre des dommages matériels en cas de non-respect des consignes.



### REMARQUE !

Ce symbole signale des informations importantes.

Lea las instrucciones y tenga en cuenta las indicaciones.

Se deberán entregar todas las instrucciones y documentos del producto al usuario final. En caso contrario la responsabilidad del fabricante puede verse restringida en caso de reclamación.

Todos los trabajos sanitarios deberán ser realizados por un instalador sanitario profesional competente y cualificado según las normas nacionales y las normas de las empresas de suministros de agua locales. Se deberán cumplir con carácter prioritario las normas locales de prevención de accidentes.

Las medidas se detallan en el anexo.

Si tiene preguntas o dudas respecto al montaje o respecto al uso póngase en contacto con el Servicio Técnico de Dornbracht.

Encontrará los datos de contacto correspondientes en el dorso de estas instrucciones y en la página web de Dornbracht: [www.dornbracht.com](http://www.dornbracht.com)



### ¡ATENCIÓN!

Este símbolo advierte de daños materiales si no se cumplen las indicaciones.



### ¡AVISO!

Este símbolo advierte sobre informaciones importantes.

- US** Care and maintenance by the user.
- DE** Pflege und Wartung durch den Benutzer.
- FR** Entretien et maintenance par l'utilisateur.
- ES** Cuidado y mantenimiento por parte del usuario.

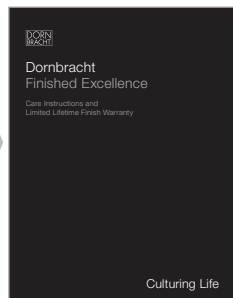

- US** Technical information.
- DE** Technische Informationen.
- FR** Informations techniques.
- ES** Información técnica.

[dornbracht.com](http://dornbracht.com)

US Required tools. DE Benötigte Werkzeuge. FR Outils nécessaires. ES Herramientas ecesarias.

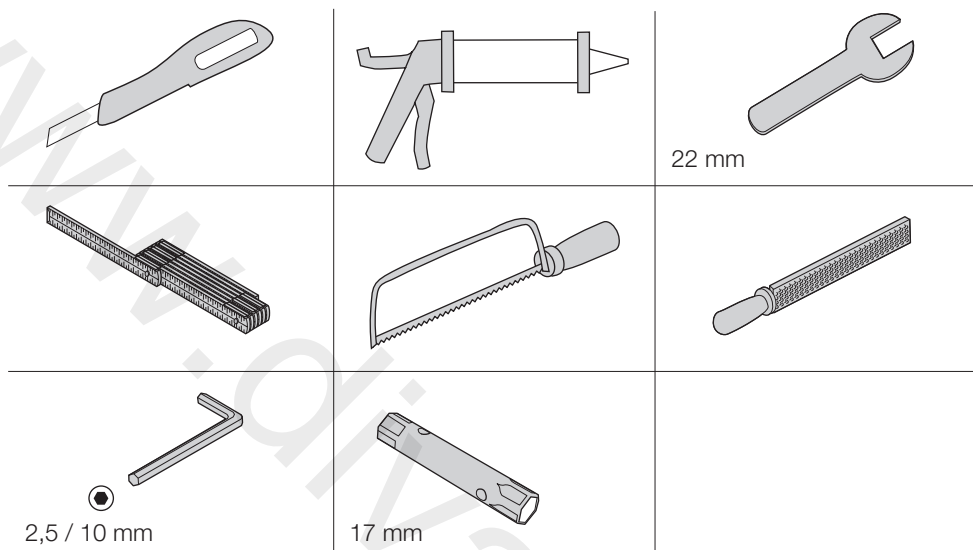

US Parts supplied. DE Lieferumfang. FR Pièces livrées. ES Volumen de suministro.

36 200 809-FF 0010 / 36 200 819-FF 0010 /  
36 200 882-FF 0010 / 36 200 892-FF 0010 / 36 200 740-FF 0010



36 210 809-FF 0010 / 36 210 819-FF 0010 /  
36 210 882-FF 0010 / 36 210 892-FF 0010 / 36 210 740-FF 0010

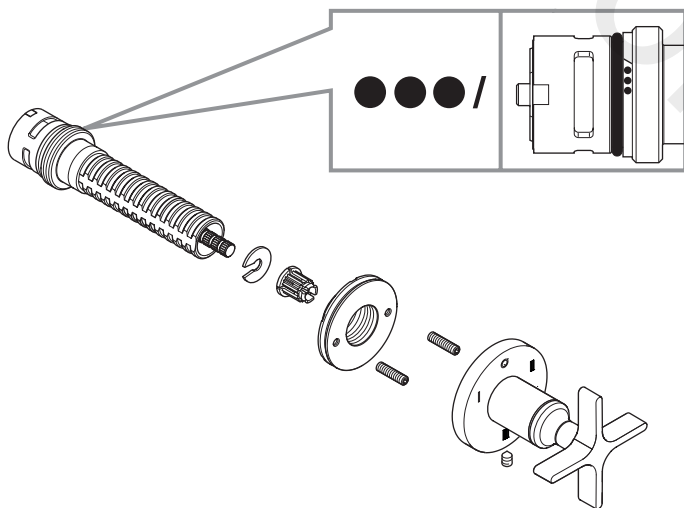

1

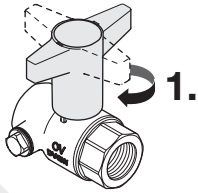

2

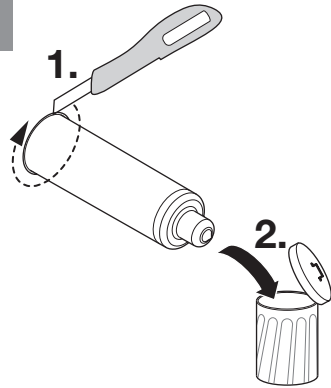

3

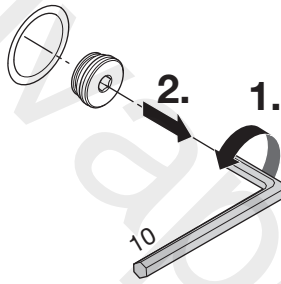

4

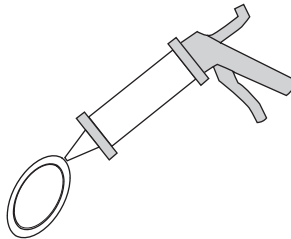

5

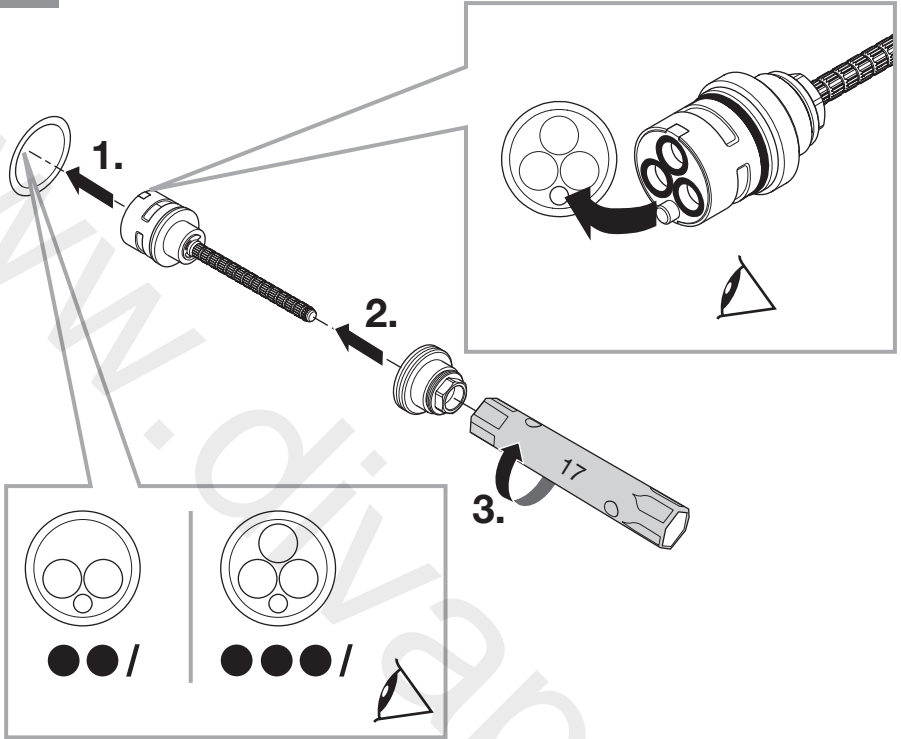

6

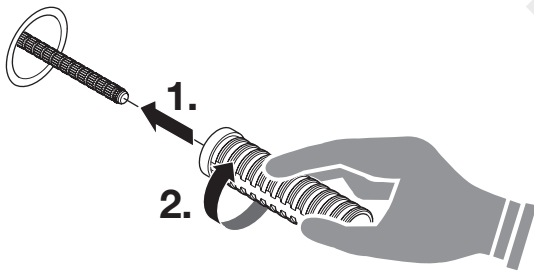

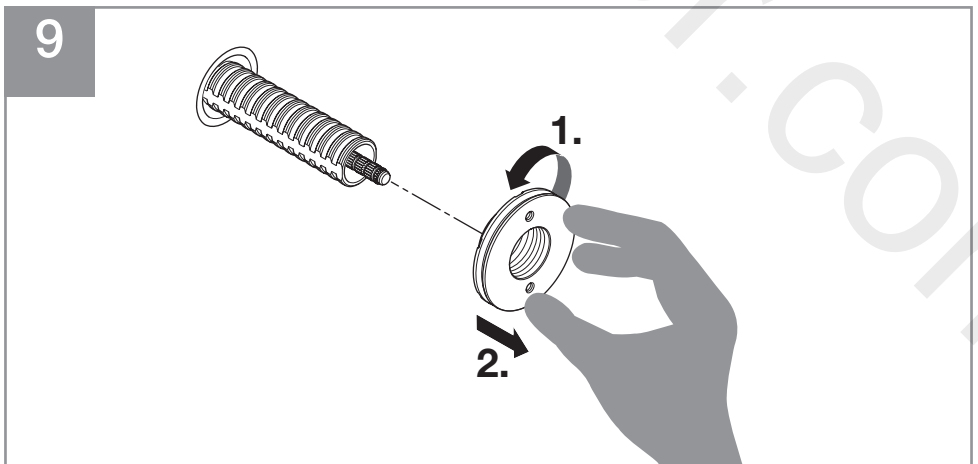
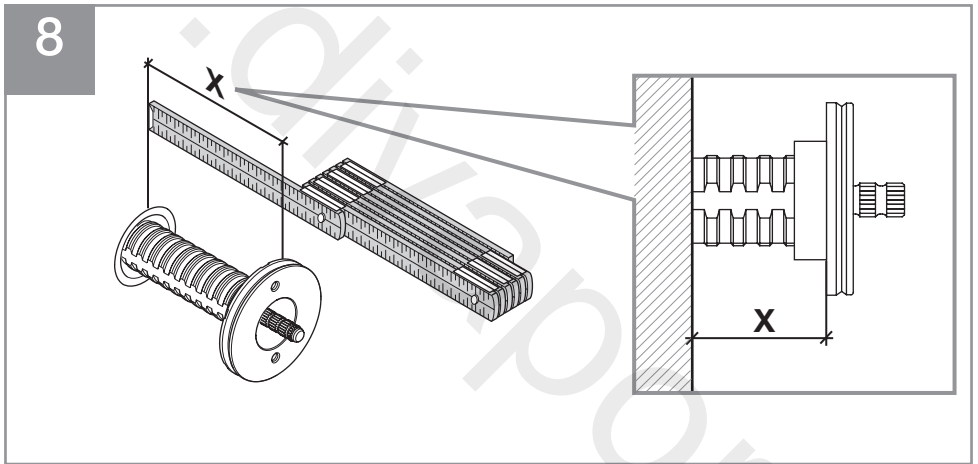
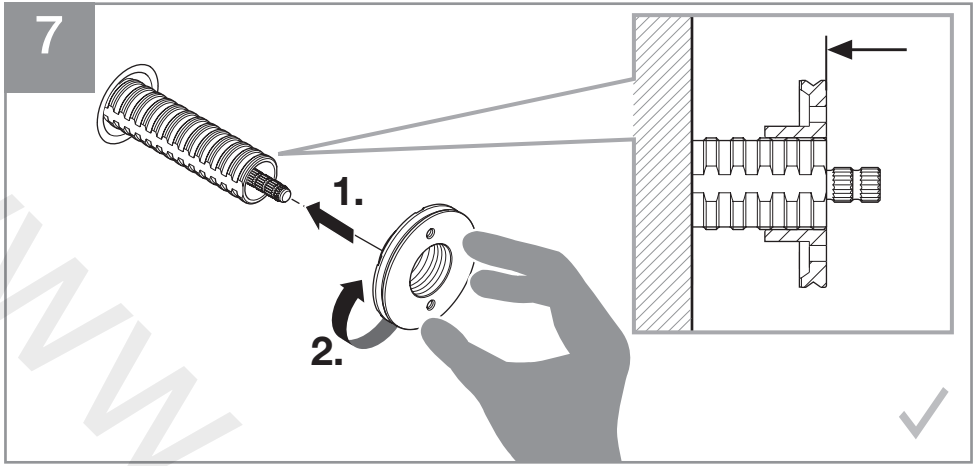

10

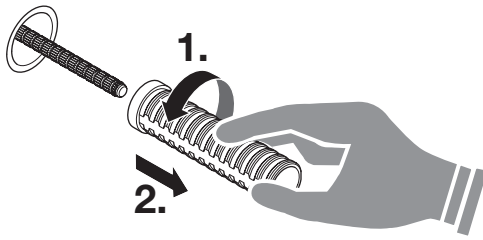

11

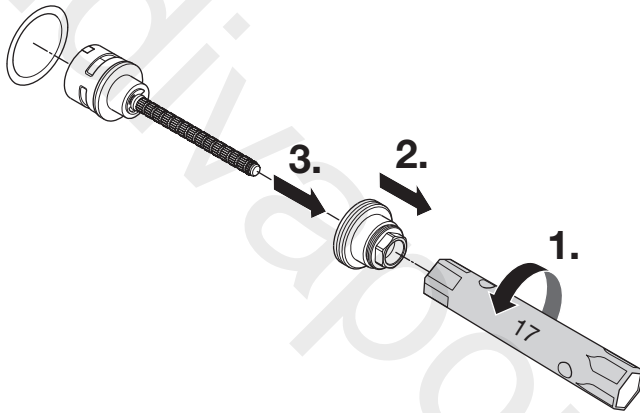

12

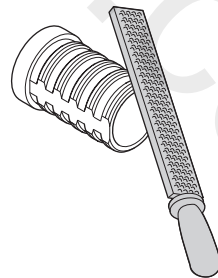
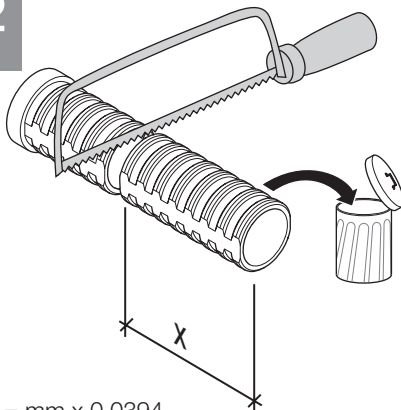

Inch = mm x 0,0394

13

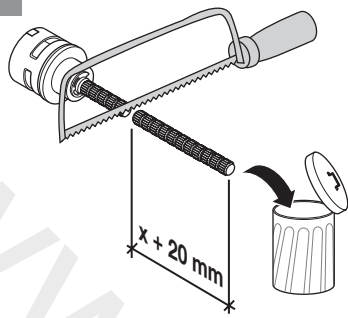

Inch = mm x 0,0394

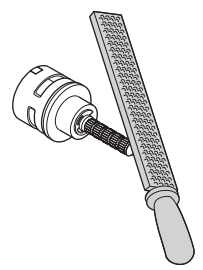

14

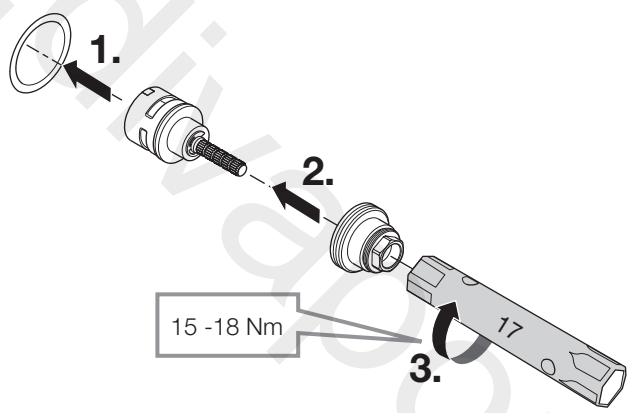

15

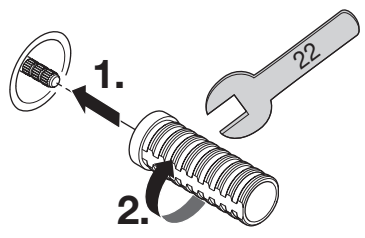

16

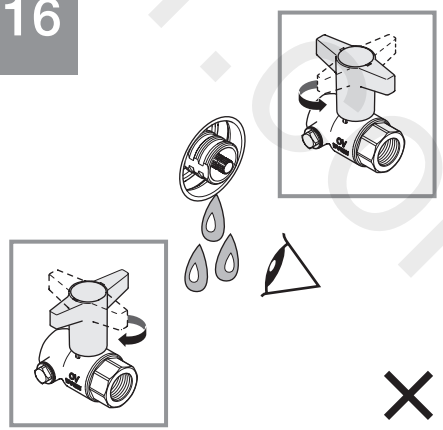

17

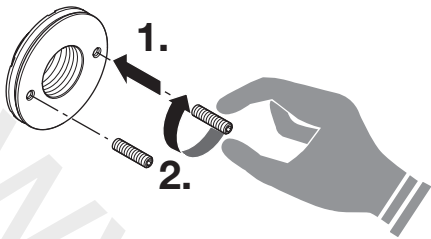

i

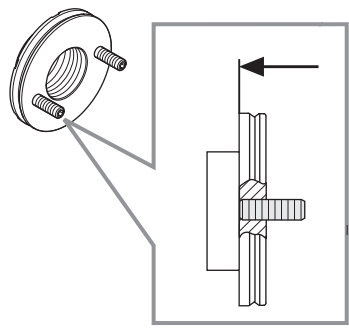

18

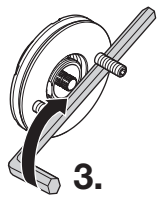
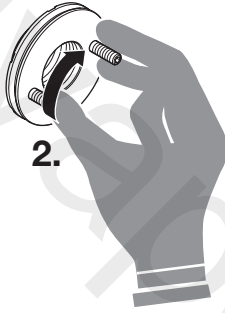
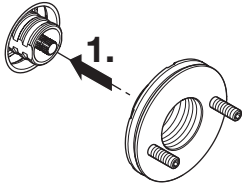

19

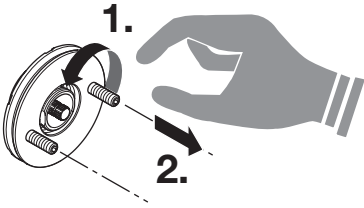

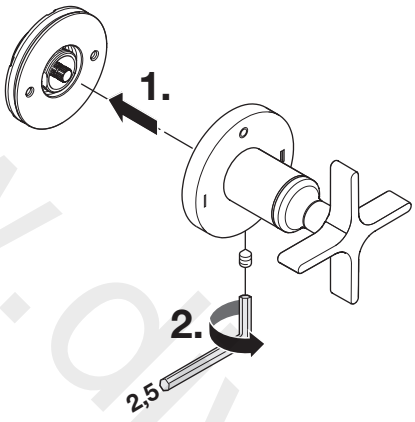

[www.divapor.com](http://www.divapor.com)

us Operation. DE Bedienung. FR Utilisation. ES Manejo.

36 200 809-FF 0010 / 36 200 819-FF 0010 / 36 200 882-FF 0010 /  
36 200 892-FF 0010 / 36 200 740-FF 0010

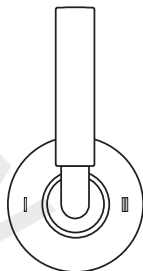

---

36 210 809-FF 0010 / 36 210 819-FF 0010 / 36 210 882-FF 0010  
36 210 892-FF 0010 / 36 210 740-FF 0010

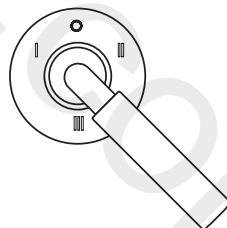
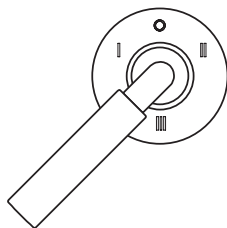
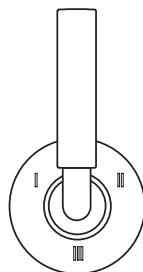

36 200 809-FF 0010

mm [inches]

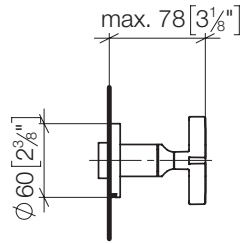
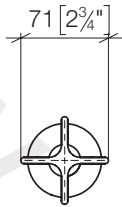

---

36 210 809-FF 0010

mm [inches]

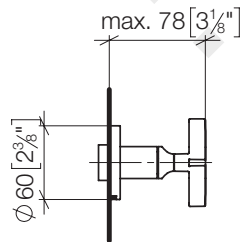
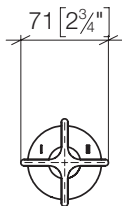

36 200 819-FF 0010

mm [inches]

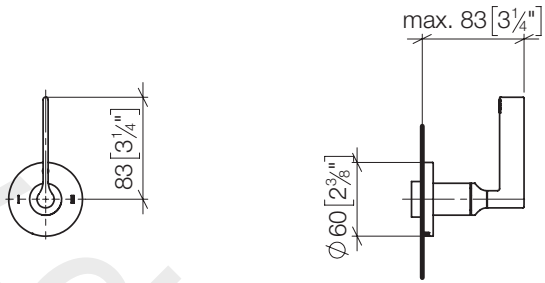

---

36 210 819-FF 0010

mm [inches]

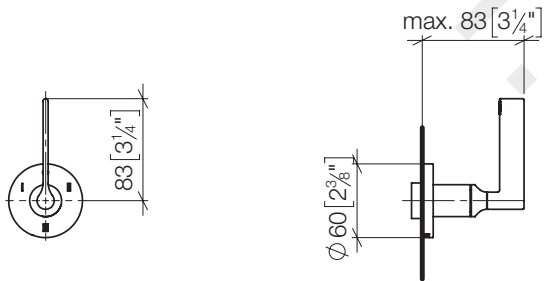

36 200 882-FF 0010

mm [inches]

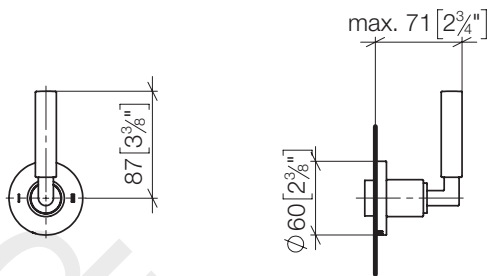

36 210 882-FF 0010

mm [inches]

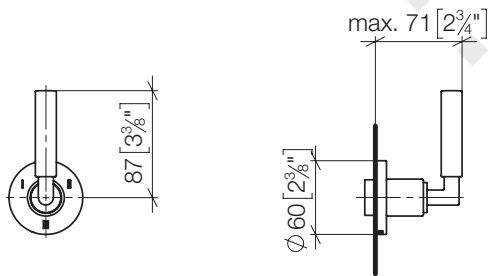

36 200 892-FF 0010

mm [inches]

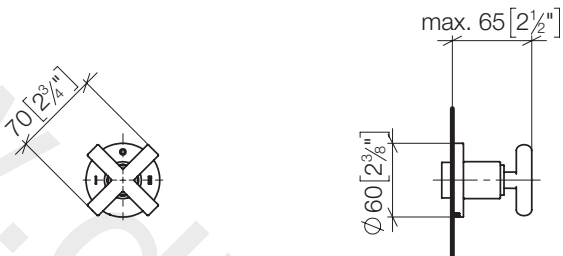

---

36 210 892-FF 0010

mm [inches]

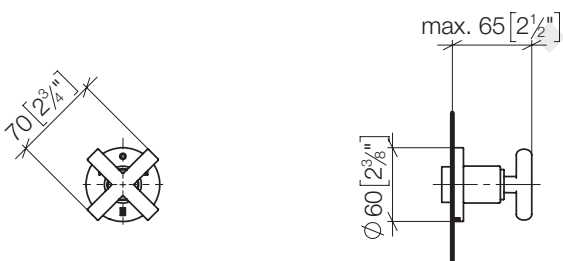

36 200 740-FF 0010 /

mm [inches]

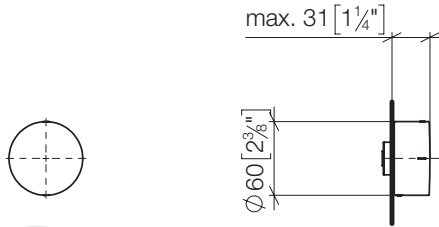

36 210 740-FF 0010

mm [inches]

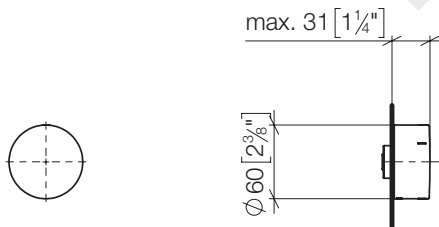

## us Operating conditions

Cold water temperature	41 – 77 °F
Hot water temperature	131 – 149 °F
Recommended hot water temperature	140 °F
Thermal disinfection (5:00 mins.)	≤ 158 °F
Permissible flow pressure	15 – 73 psi
Recommended flow pressure	45 psi

The customer has to provide a pressure reducer in the main line downstream of the water meter to comply with the noise levels according to the noise class at a resting pressure above 500 kPa / 73 psi / 5 bar.

If combined with continuous-flow heaters, the minimum flow volume of the safety shut-off has to be considered.

Observe the manufacturer's instructions for the continuous-flow heater.

## DE Betriebsbedingungen

Kaltwassertemperatur	5 – 25 °C
Warmwassertemperatur	55 – 65 °C
Empfohlene Warmwassertemperatur	60 °C
Thermische Desinfektion (5:00 Min.)	≤ 70 °C
Zulässiger Fließdruck	1 – 5 bar
Empfohlener Fließdruck	3 bar

Ein Druckminderer ist bauseits in der Hauptleitung hinter dem Wasserzähler einzubauen, um bei einem Ruhedruck über 500 kPa / 73 psi / 5 bar die Geräuschwerte der Geräuschklasse einzuhalten.

Bei Kombination mit Durchlauferhitzern ist die Mindestdurchflussmenge der Sicherheitsabschaltung zu berücksichtigen.

Beachten Sie die Herstellerhinweise des Durchlauferhitzers.

## FR Conditions de fonctionnement

Température de l'eau froide	5 – 25 °C
Température de l'eau chaude	55 – 65 °C
Température de l'eau chaude recommandée	60 °C
Désinfection thermique (5:00 min)	≤ 70 °C
Pression dynamique admissible	1 – 5 bar
Pression dynamique recommandée	3 bar

Un réducteur de pression doit être monté sur site dans la conduite principale derrière le compteur d'eau afin de respecter, en cas de pression statique supérieure à 500 kPa / 73 psi / 5 bar, les niveaux sonores de la catégorie correspondante.

En cas d'installation combinée avec un chauffe-eau instantané, le débit d'eau minimal de la coupure de sécurité doit être pris en compte.

Observez les consignes du fabricant du chauffe-eau instantané.

## ES Condiciones de funcionamiento

Temperatura de agua fría	5 – 25 °C
Temperatura de agua caliente	55 – 65 °C
Temperatura de agua caliente recomendada	60 °C
Desinfección térmica (5:00 min)	≤ 70 °C
Presión hidráulica permitida	1 – 5 bar
Presión hidráulica recomendada	3 bar

Se deberá prever en la obra la instalación de una válvula reductora de la presión en la tubería general detrás del contador del agua, para mantener los valores de ruido de la clase de ruido en el caso de una presión de reposo superior a 500 kPa / 73 psi / 5 bar.

En caso de combinación con calentadores de agua continuos se deberá considerar el caudal mínimo de la desconexión de seguridad.

Respete las indicaciones del fabricante del calentador de agua continuo.

Dornbracht AG & Co. KG  
Köbbingser Mühle 6, D-58640 Iserlohn  
Tel. +49 2371 8899-900  
Fax +49 2371 433-232  
mail@dornbracht.de  
www.dornbracht.com

www.divapor.com



01 03 10 887 00 / 12.2021