

AXOR

www.diverap.com

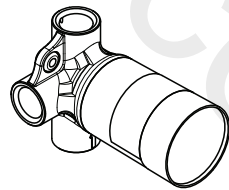
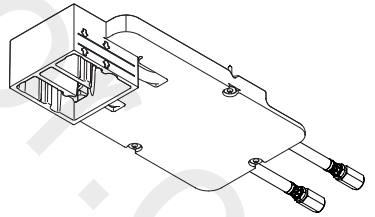

EN Installation / User Instructions / Warranty
FR Instructions de montage / Mode d'emploi / Garantie
ES Instrucciones de montaje / Manejo / Garantía

AXOR
35363181

INSTALLATION

ENGLISH

TECHNICAL INFORMATION

Water pressure	
Recommended	15 - 75 PSI (0.1 - 0.5 MPa)
Maximum	145 PSI (1 MPa)
Hot water temp.	
Recommended	120°-140° F (48° - 60° C)*
Maximum	158°F (70° C)*
Maximum flow rate of showerhead:	
35298xx1, 35313xx1	2.5 GPM (9.5 L/min)
35366xx1, 35315xx1	1.75 GPM (6.6 L/min)

* Please know and follow all applicable local plumbing codes when setting the temperature on the water heater.

INSTALLATION CONSIDERATIONS

- / For best results, Hansgrohe recommends that this unit be installed by a licensed, professional plumber.
- / Please plan your installation carefully. Read over the installation instructions for all components. Make sure that you have all tools and supplies needed to complete the installation. If you have any questions, please contact Hansgrohe Technical Service before beginning installation.
- ⚠ This rough is for installation in a suspended ceiling.
- / This rough is for use with AXOR ShowerSolutions showerheads (not included) 35298xx1, 35313xx1, 35366xx1, 35315xx1.
- / This unit must be installed with the included Trio Green diverter #30371441 or with Quattro Green diverter #15936181 (not included - sold separately).
- / The trim kit for the Trio Green is sold separately.
- ⚠ If required by code, install a grounding wire at the mounting location. The grounding wire will be connected to the showerhead when the showerhead is installed.
- / There are no controls on the showerheads. The spray functions are controlled by the diverter.
- / To prevent scald injury, the maximum output temperature of the shower valve must be no higher than 120°F (49° C). In Massachusetts, the maximum output temperature can be no higher than 112°F (44°C).
- / Keep this booklet and the receipt (or other proof of

DONNÉES TECHNIQUES

Pression d'eau	
recommandée	15 - 75 PSI (0.1 - 0.5 MPa)
maximum	145 PSI (1 MPa)
Température d'eau chaude	
recommandée	120°-140° F (48° - 60° C)*
maximum	158°F (70° C)*
Capacité nominale de la pomme de douche:	
35298xx1, 35313xx1	2.5 GPM (9.5 L/min)
35366xx1, 35315xx1	1.75 GPM (6.6 L/min)

* Vous devez connaître et respecter tous les codes de plomberie locaux applicables pour le réglage de la température du chauffe-eau.

À PRENDRE EN CONSIDÉRATION POUR L'INSTALLATION

- / Pour de meilleurs résultats, Hansgrohe recommande que ce produit soit installé par un plombier professionnel licencié.
- / Préparez-vous bien avant de commencer. Lisez les instructions d'installation de tous les composants. Assurez-vous de disposer de tous les outils et du matériel nécessaires pour l'installation. Si vous avez des questions, veuillez contacter l'assistance technique de Hansgrohe avant de commencer l'installation.
- ⚠ Le kit de base ne peut être monté que dans un plafond intermédiaire.
- / Cette pièce intérieure est conçue pour utilisation avec les pommes de douche Ne de la gamme AXOR ShowerSolutions (non compris) 35298xx1, 35313xx1, 35366xx1, 35315xx1.
- / Cette pomme de douche doit être installée avec l'inverseur Trio Green n° 30371441 (inclus) ou avec l'inverseur Quattro Green n° 15936181 (non compris)
- / L'ensemble de garniture pour le Trio Green est vendu séparément.
- ⚠ Si le code l'exige, installez un fil de terre à l'emplacement de montage. Le fil de terre sera connecté à la pomme de douche lorsqu'elle sera installée.
- / Les pommes de douche ne disposent pas de boutons de contrôle. Les modes de jet sont commandés par l'inverseur.
- / Pour empêcher des blessures par ébullition, la température de sortie maximale du robinet de douche ne doit pas excéder 120°F (49°C). Au Massachusetts, la température de sortie maximale du robinet de douche ne doit pas excéder 112°F (44°C).
- / Conservez ce livret et le reçu (ou une autre preuve sur laquelle figurent la date et l'endroit de l'achat) pour ce produit dans un endroit sûr. Le reçu est requis si vous commandez des pièces sous garantie.

DATOS TECNICOS

Presión en servicio	
recomendada	15 - 75 PSI (0.1 - 0.5 MPa)
max.	145 PSI (1 MPa)
Temperatura del agua caliente	
recomendada	120°-140° F (48° - 60° C)*
max.	158°F (70° C)*
Caudal máximo de la ducha cabezal:	
35298xx1, 35313xx1	2.5 GPM (9.5 L/min)
35366xx1, 35315xx1	1.75 GPM (6.6 L/min)

* Debe conocer y cumplir todos los códigos locales aplicables para ajustar la temperatura del calentador de agua.

CONSIDERACIONES PARA LA INSTALACIÓN

- / Para obtener mejores resultados, la instalación debe estar a cargo de un plomero profesional matriculado.
- / Planifique la instalación cuidadosamente. Repase las instrucciones de instalación para todos los componentes. Asegúrese de tener las herramientas y los insumos necesarios para completar la instalación. Si tiene alguna pregunta, comuníquese con el Servicio técnico de Hansgrohe antes de comenzar la instalación.
- ⚠ El kit base può essere installato solo in un soffitto intermedio.
- / Esta pieza interior se usa con las duchas cabezales de la Colección de AXOR ShowerSolutions (no incluida) 35298xx1, 35313xx1, 35366xx1, 35315xx1.
- / Esta ducha debe instalarse con un distribuidor Trio Green #30371441 (incluido) o con un distribuidor Quattro Green #15936181 (no incluido).
- / El juego de pieza exterior para el distribuidor Trio Green se vende por separado.
- ⚠ Si el código lo requiere, instale un cable de tierra en la ubicación de montaje. El cable de tierra estará conectado al cabezal de ducha en la instalación.
- / No hay controles en las duchas cabezales. Las funciones de rociado se controlan mediante el distribuidor.
- / Para evitar escaldaduras, la máxima temperatura de salida de la válvula de la ducha no debe exceder los 120°F (49° C). En Massachusetts, la máxima temperatura de salida de la válvula de la ducha no debe exceder los 112°F (44°C).
- / Mantenga este folleto y el recibo (u otro comprobante del lugar y fecha de compra) de este producto en lugar seguro. El recibo se requiere en caso de ser necesario solicitar piezas bajo garantía.

AXOR
35363181

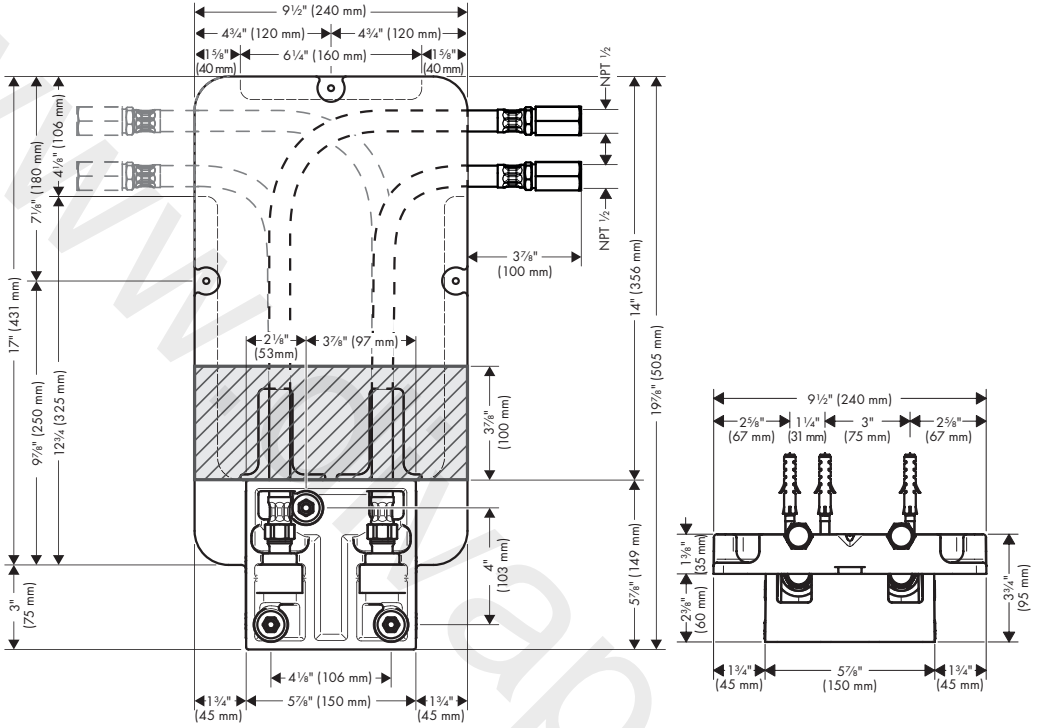

Trio Green
30371441

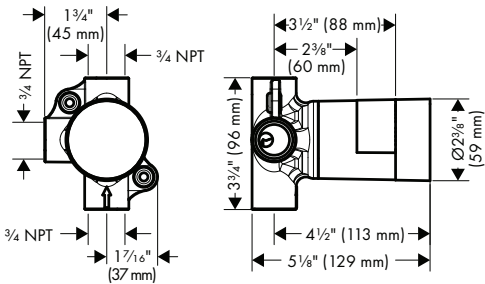

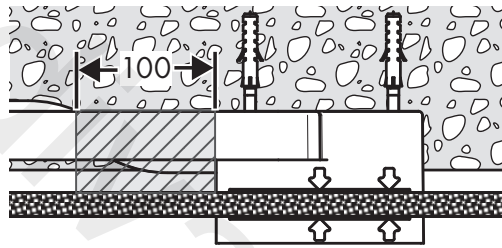
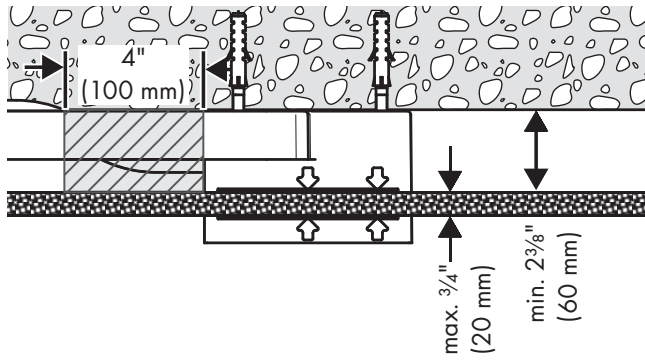

NO!

TOOLS REQUIRED / Outils Utiles /
HERRAMIENTAS ÚTILES

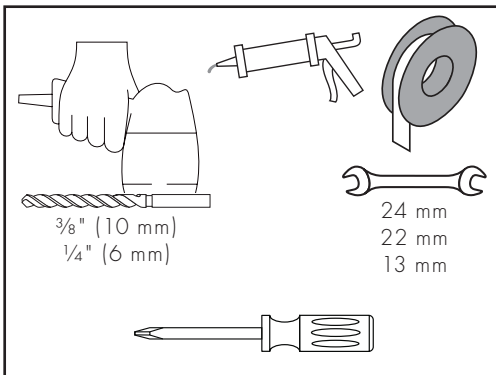

REPLACEMENT PARTS / PIÈCES DÉTACHÉES / REPUESTOS

AXOR
35363181

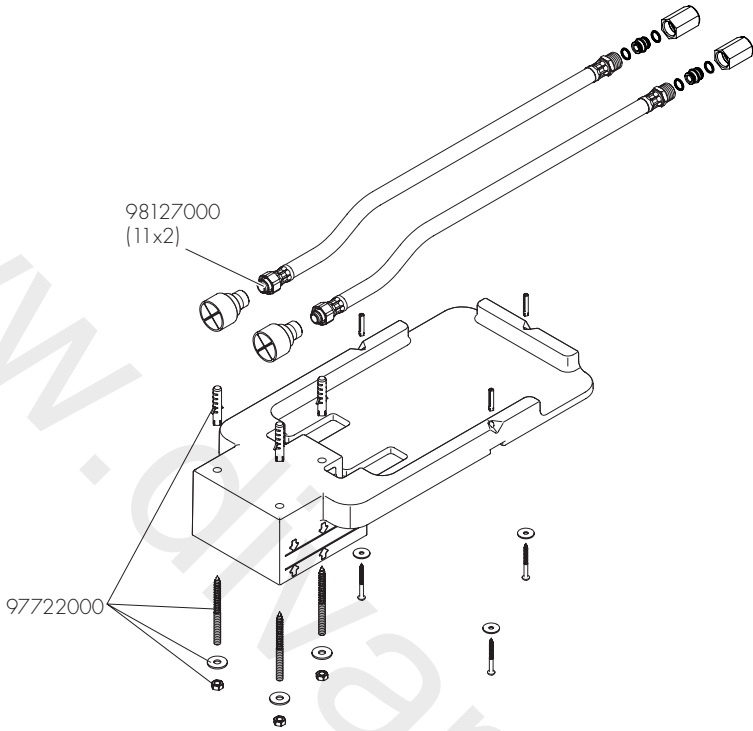

Trio Green
30371441

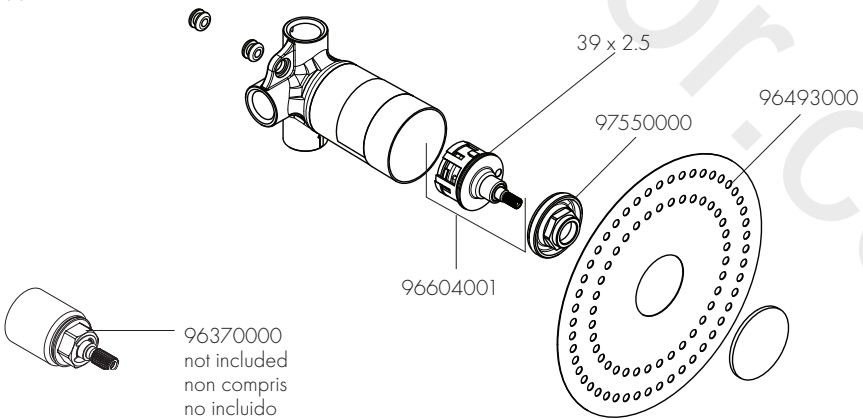

INSTALLATION SUGGESTIONS / SUGGESTIONS D'INSTALLATION / SUGERENCIAS PARA LA INSTALACIÓN

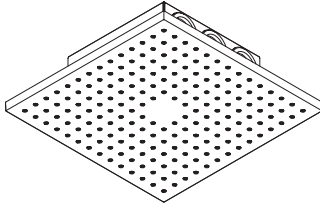
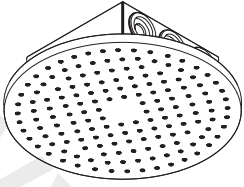

AXOR 250 2jet
35298xx1
35366xx1

AXOR 250/250 2jet
35313xx1
35315xx1

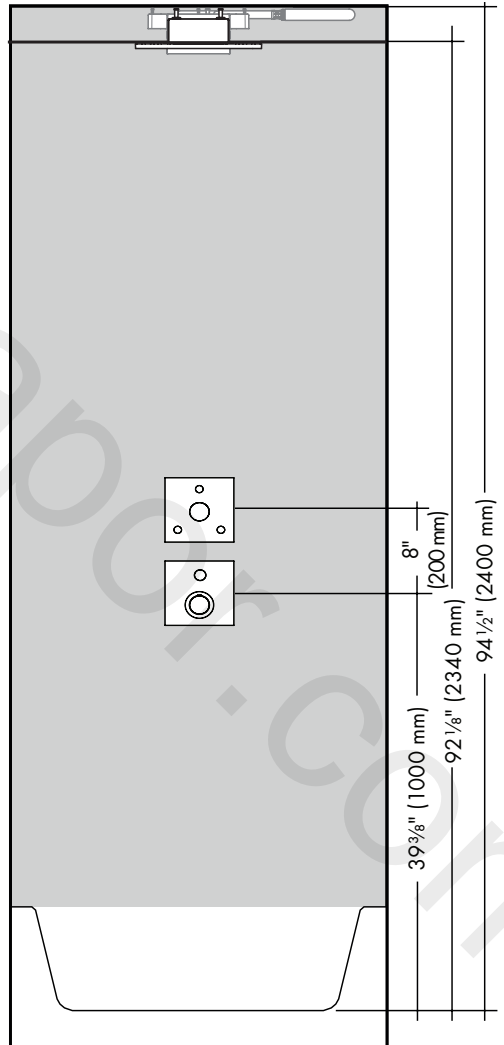
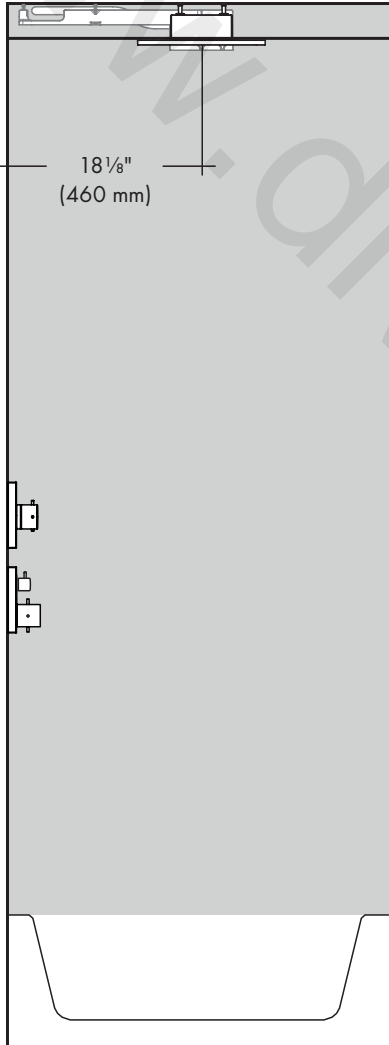

 PowderRain

 Intense PowderRain

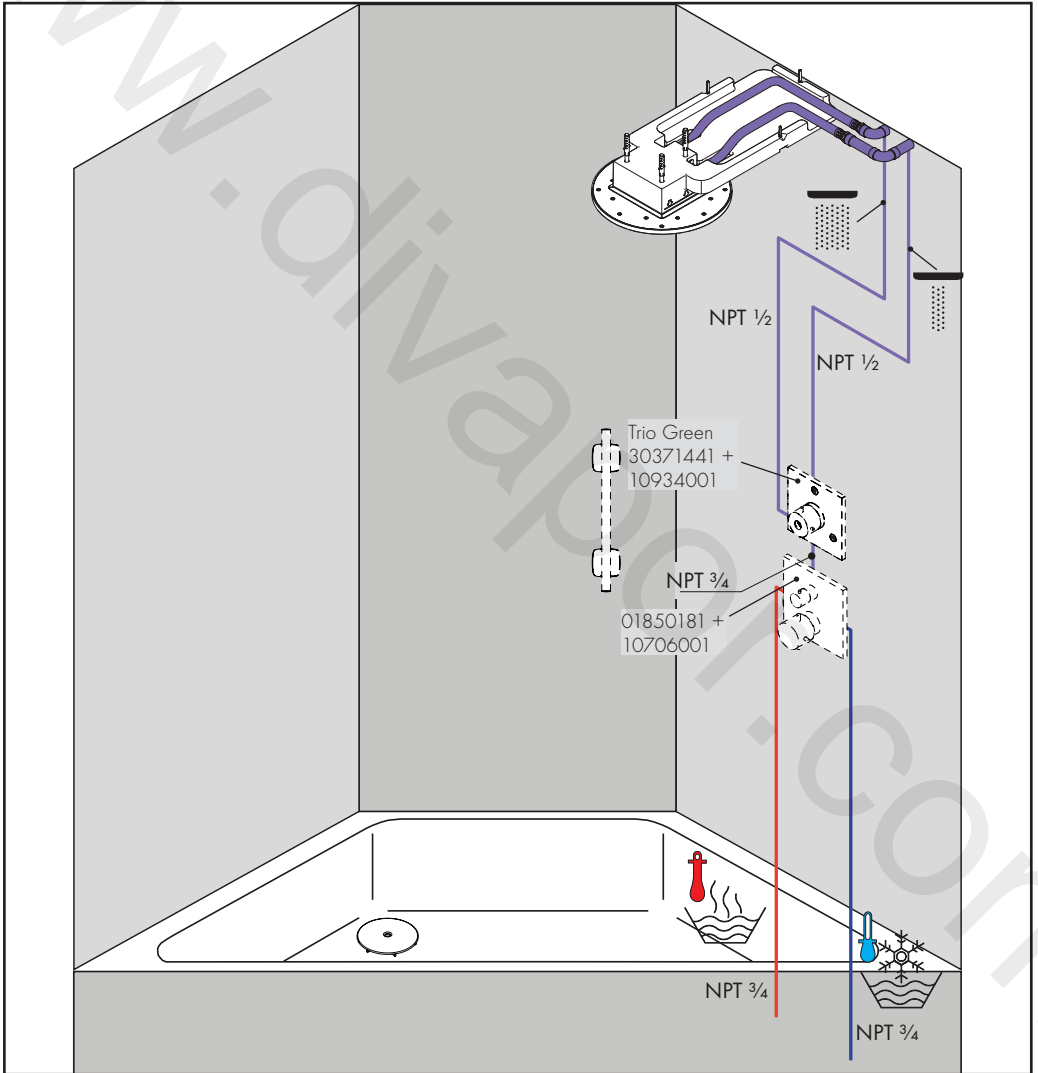

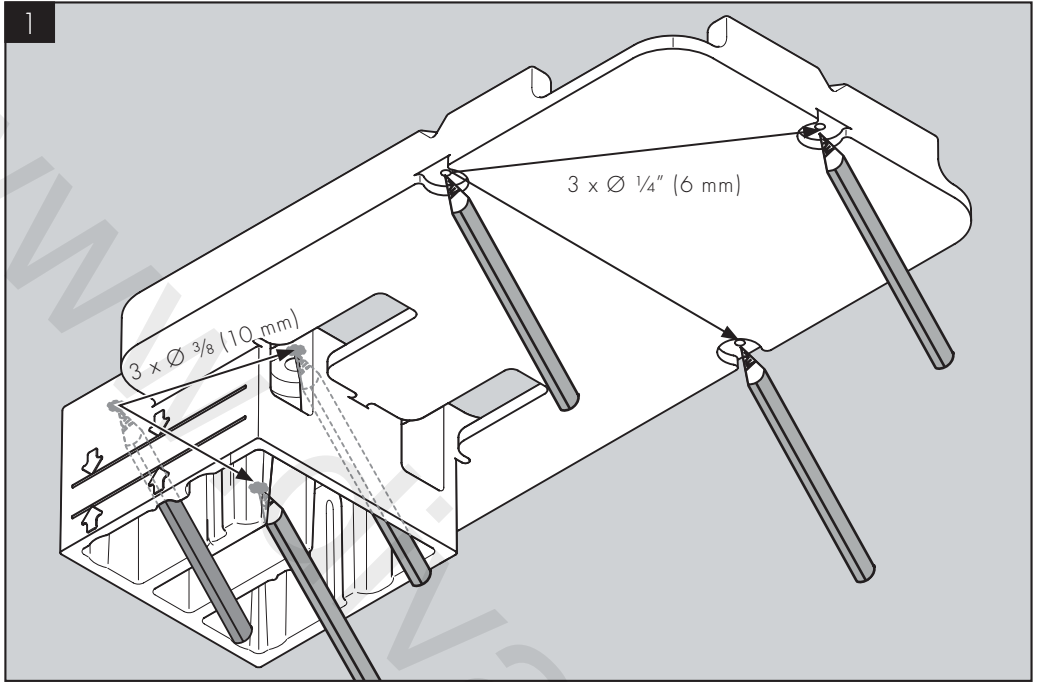

ENGLISH

FRANÇAIS

ESPAÑOL

Hold the rough against the mounting surface.

Maintenez la pièce intérieure contre la surface de montage.

Mantenga la pieza interior contra la superficie de montaje.

Mark the positions of three screw holes in the shallow section of the rough.

Marquez les positions des trois trous de vissage dans la section peu profonde de la pièce intérieure.

Marque la posición de los tres orificios para tornillos en la sección superficial de la pieza interior.

Mark the positions of three screw holes in the deeper dummy section of the rough.

Marquez les positions des trois trous de vissage dans la section du patron de montage plus profonde de la pièce intérieure.

Marque la posición de los tres orificios para tornillos en la sección más profunda de la plantilla de la pieza interior.

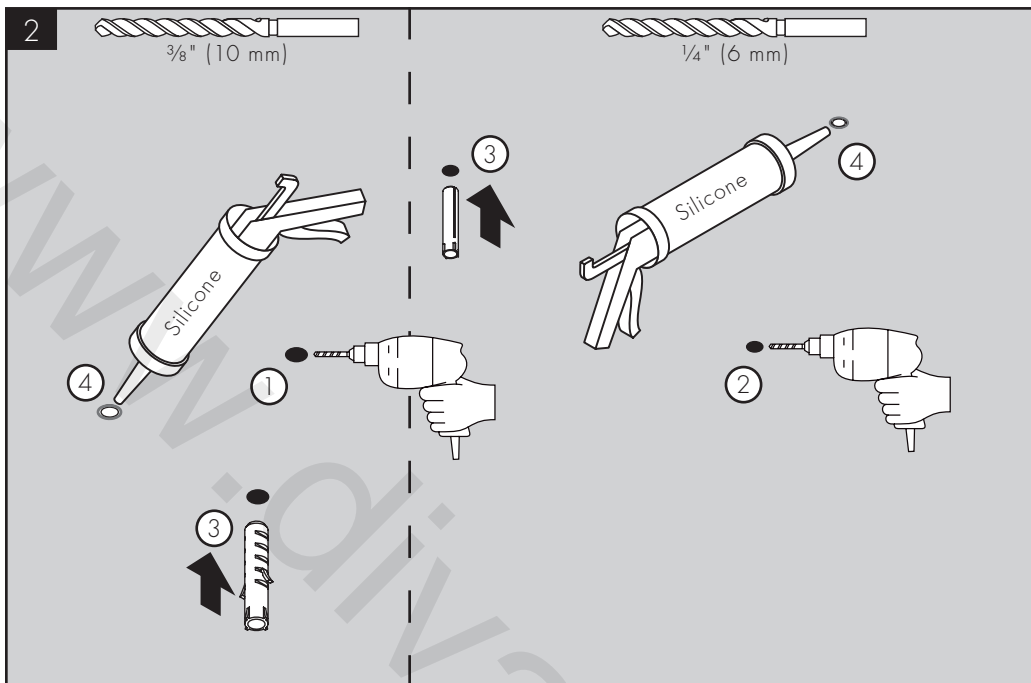

ENGLISH

Remove the rough.

Drill the three holes for the dummy section using a $\frac{3}{8}$ " (10 mm) bit.

Drill the three holes for the shallow section using a $\frac{1}{4}$ " (6 mm) bit.

Install the anchors.

Seal the mounting surface around the anchors using waterproof sealant.

FRANÇAIS

Enlevez la pièce intérieure.

Percez les trois trous dans la section du patron de montage à l'aide d'une mèche de $\frac{3}{8}$ po (10 mm).

Percez les trois trous dans la section peu profonde à l'aide d'une mèche de $\frac{1}{4}$ po (6 mm).

Installez les chevilles.

Scellez la surface de montage autour des chevilles à l'aide d'un agent d'étanchéité.

ESPAÑOL

Retire la pieza interior.

Perfore los orificios para la sección superficial con una broca de $\frac{3}{8}$ " (10 mm).

Perfore los orificios para la sección superficial con una broca de $\frac{1}{4}$ " (6 mm).

Instale los pernos de anclaje.

Selle la superficie de montaje alrededor de los pernos de anclaje con un sellador impermeable.

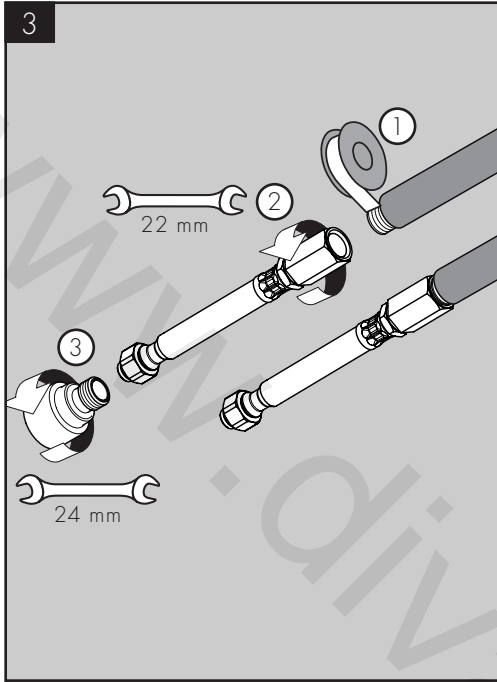

ENGLISH

Wrap the threads on the supply pipes using plumber's tape.

Install the hoses on the supply pipes.

Remove the plugs.

⚠ Do not discard the plugs!

FRANÇAIS

Enroulez les filets sur les tuyaux à l'aide de ruban de plomberie.

Installez les tuyaux/sur les tuyaux d'alimentation.

Retirez les bouchons.

⚠ Ne jetez pas les bouchons!

ESPAÑOL

Envuelva las roscas de las tuberías de suministro con cinta de plomero.

Instale las mangueras en las tuberías de suministro.

Retire los tapones.

⚠ ¡No deseche los tapones!

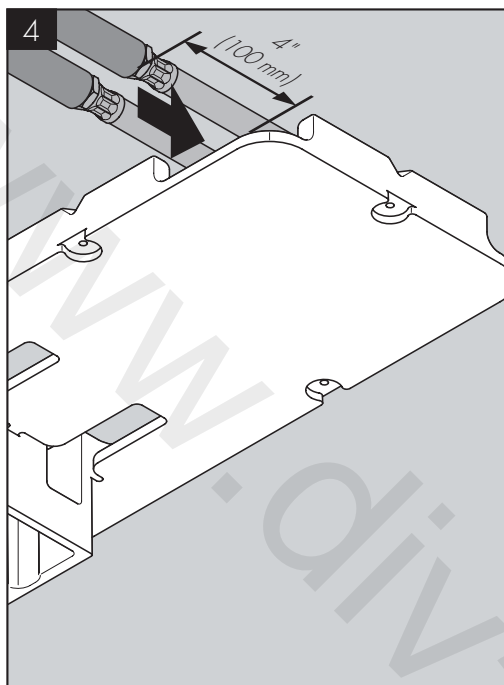

ENGLISH

Guide the hoses into the rough.

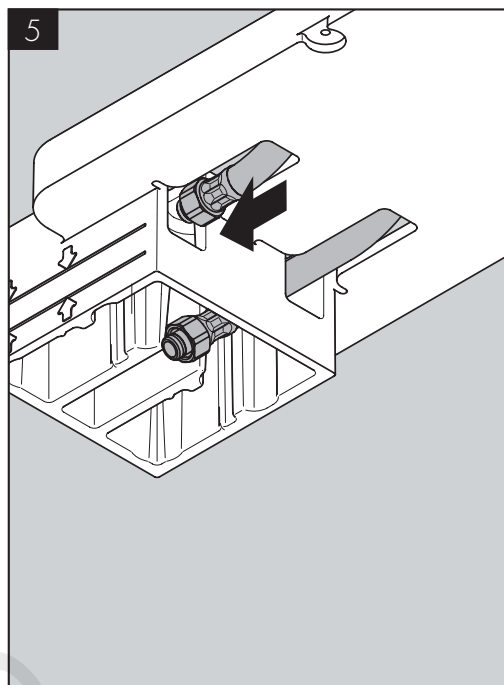

FRANÇAIS

Guidez les tuyaux dans la pièce intérieure.

ESPAÑOL

Guíe las mangueras en la pieza interior.

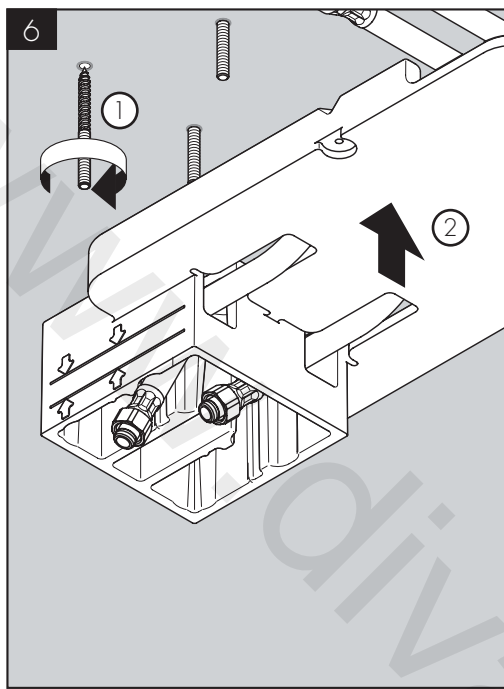

ENGLISH

Install the studs in the larger three anchors.

Push the rough over the studs.

No more than $\frac{3}{8}$ " (10 mm) of the studs should extend into the dummy.

FRANÇAIS

Installez les goujons dans les trois plus grandes chevilles.

Poussez la pièce intérieure sur les goujons.

Une partie d'au plus $\frac{3}{8}$ po (10 mm) des goujons doit dépasser dans le patron de montage.

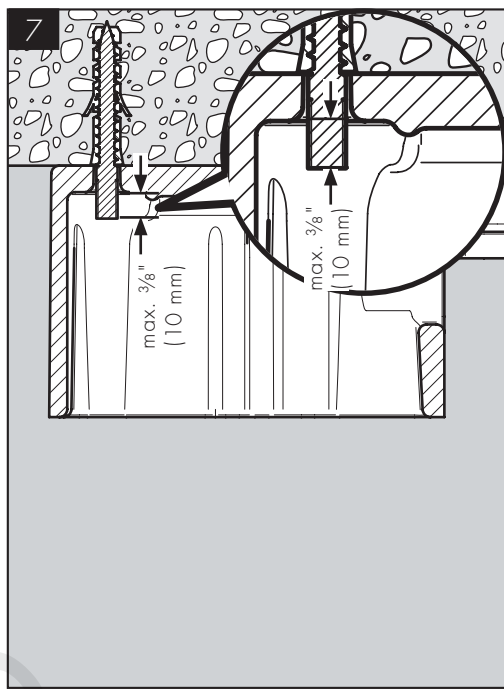

ESPAÑOL

Instale los tornillos espárrago en los tres pernos de anclaje más grandes.

Presione la pieza interior sobre los tornillos espárrago.

Estos tornillos no deben extender más de $\frac{3}{8}$ " (10 mm) en la plantilla.

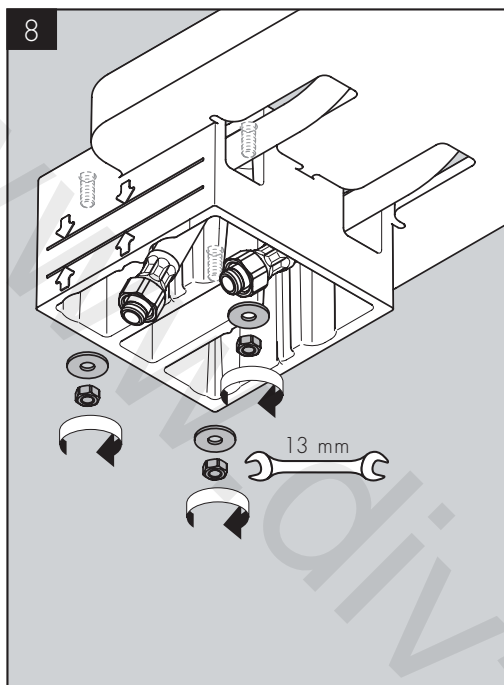

ENGLISH

Install the washers and nuts over studs.

Install washers and screws in the smaller anchors.

FRANÇAIS

Installez les rondelles et les écrous sur les goujons.

Installez les rondelles et les vis dans les plus petites chevilles.

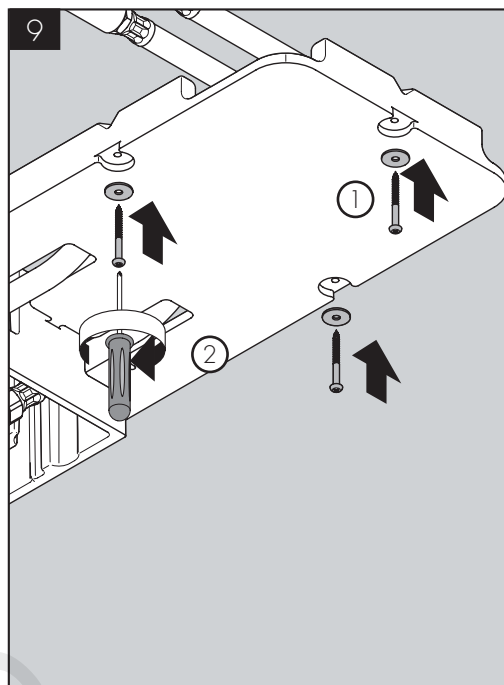

ESPAÑOL

Instale las tuercas y las arandelas en los tornillos espárragos.

Instale las arandelas y tornillos en los pernos de anclaje más chicos.

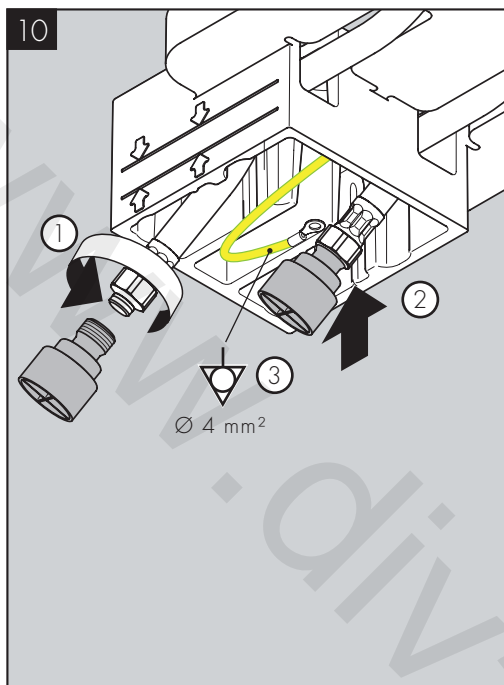

ENGLISH

Install the plugs on the hoses. Tuck the hoses back into the rough.

If a grounding wire is required by local code, install it and guide the end into the dummy.

Install the finished ceiling. The outside surface must fall between the "min" and "max" lines on the dummy section.

FRANÇAIS

Installez les bouchons sur les tuyaux. Remettez les tuyaux en place dans la pièce intérieure.

Si un fil de terre est requis par le code local, installez-le et guidez l'extrémité dans le patron de montage.

Installez le plafond fini. La surface extérieure doit se situer entre les lignes « min » et « max » figurant sur la section du patron de montage.

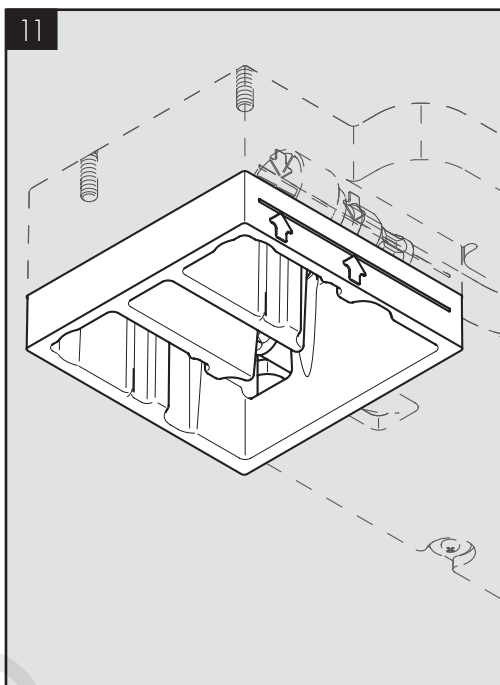

ESPAÑOL

Instale los tapones en las mangueras. Inserte las mangueras en la pieza interior.

Si el código le exige que instale un cable de tierra, instálolo y guíelo hacia dentro de la plantilla.

Instale el acabado del cielo raso. La superficie exterior debe estar entre las líneas de 'mín.' y 'máx.' sobre la sección de la plantilla.

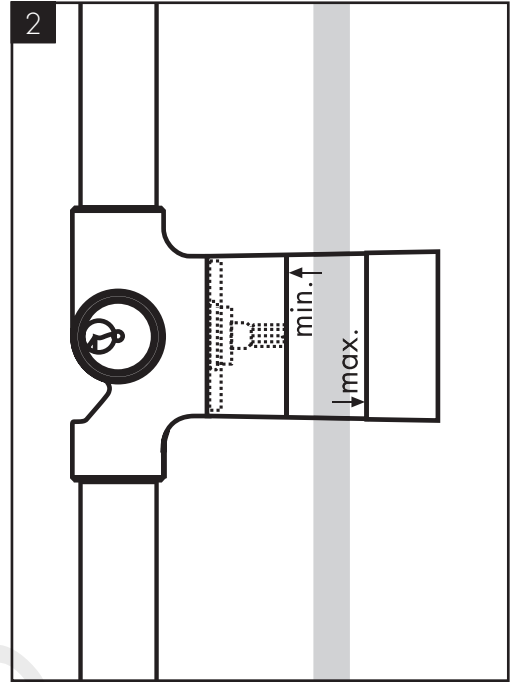
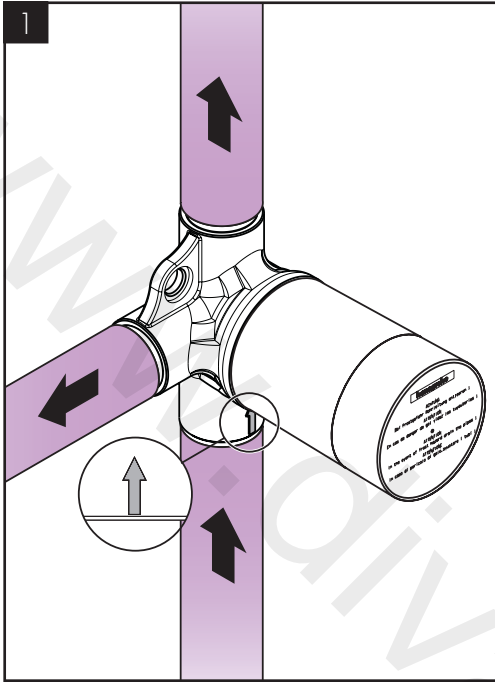

ENGLISH

FRANÇAIS

ESPAÑOL

An arrow showing the direction of the water flow is cast into the valve body.

Une flèche indiquant la direction du débit figure sur le corps de la valve.

En el cuerpo de la válvula está fundida una flecha que muestra el sentido del flujo de agua.

⚠ The water must flow through the valve in that direction or damage to the cartridge will occur.

⚠ Si l'eau ne coule pas dans la valve dans cette direction, la cartouche sera endommagée.

⚠ El agua debe circular por la válvula en ese sentido, puesto que de lo contrario puede dañarse el cartucho.

Install the valve so that the outside surface of the finished wall falls between the "minimum" and "maximum" lines marked on the plaster shield.

Installez la valve de façon à ce que la surface extérieure du mur fini tombe entre les lignes « minimum » et « maximum » figurant sur le protecteur de plâtre.

Instale la válvula de modo que la superficie exterior de la pared terminada quede entre las líneas "min" y "max" marcadas en el protector de yeso.

⚠ Do not remove the plaster shield from the valve.

⚠ Ne retirez pas le protecteur de plâtre de la valve.

⚠ No retire el protector de yeso de la válvula.

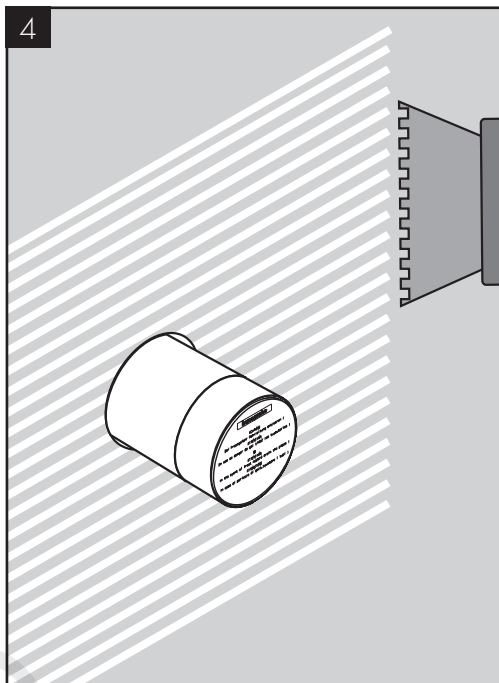
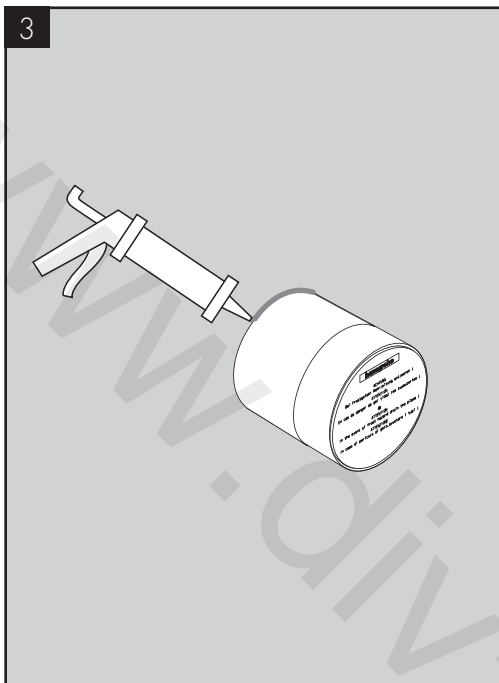

ENGLISH

Install the sheet rock or green board.

Seal the wall between the sheet rock or green board and the rough valve using waterproof sealant.

Spread adhesive on the wall around the rough.

⚠ Do not use hot glue.

FRANÇAIS

Installez le panneau de plâtre.

Scellez l'espace entre le panneau de plâtre et le boîtier d'installation en utilisant un agent d'étanchéité.

Appliquez un adhésif sur le mur et le boîtier.

⚠ N'utilisez pas de colle chaude.

ESPAÑOL

Instale la placa de yeso.

Selle el espacio entre la placa de yeso y la caja de instalación con un sellador impermeable.

Aplique adhesivo a la pared y a la caja.

⚠ No use cola caliente.

5

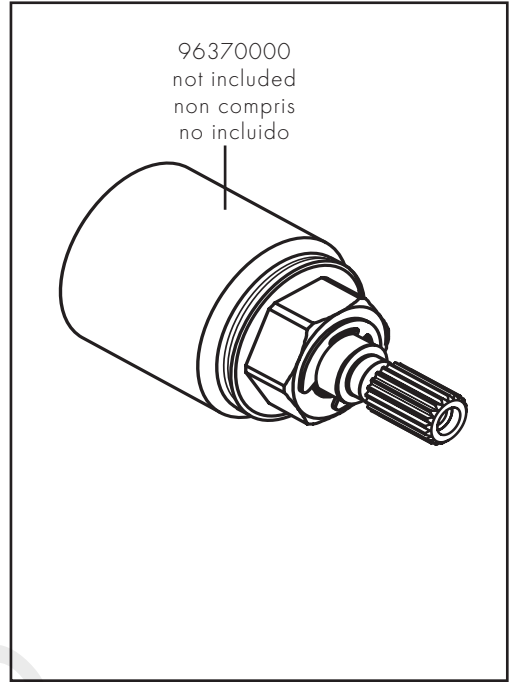
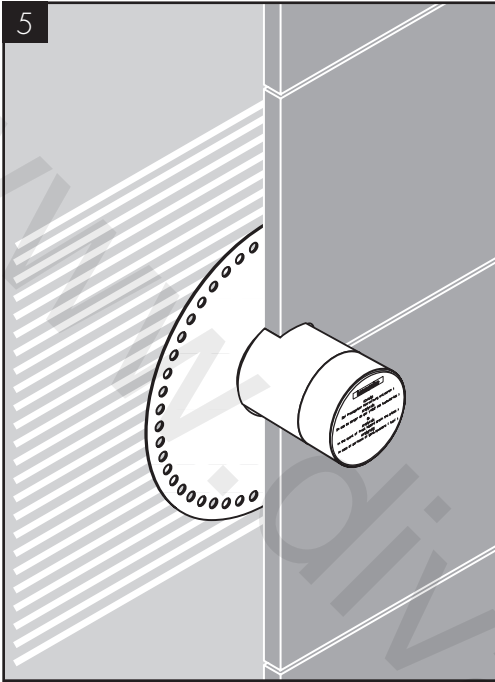

ENGLISH

Install the gasket.

Install the tile or other finished wall surface over the gasket and against the rough.

If the outside surface of the finished wall extends beyond the "maximum" marking on the plaster shield, order extension 96370000 through your Hansgrohe dealer for the Trio Green diverter.

FRANÇAIS

Installez le collet d'étanchéité.

Installez la surface de mur fini sur le collet d'étanchéité et contre le boîtier d'installation.

Si la surface extérieure du mur fini va au-delà de la marque « maximum » du protecteur de plâtre, commandez une rallonge 96370000 auprès de votre détaillant Hansgrohe.

ESPAÑOL

Instale el collar de sellado.

Instale la superficie de la pared terminada sobre el collar de sellado y contra la caja de instalación.

Si la superficie exterior de la pared terminada se extiende más allá de la marca de "máximo" del protector de yeso, solicite la extensión 96370000 al concesionario de Hansgrohe.

www.divapor.com

www.divapor.com

HANSGROHE, INC. LIMITED WARRANTY

Offering our customers the highest quality at all times is a fundamental part of the Hansgrohe, Inc. company philosophy. We offer consumers a limited warranty on our hansgrohe® and AXOR® branded products.

This warranty is limited to products manufactured by Hansgrohe, Inc. that are purchased from a Hansgrohe, Inc. authorized seller by a consumer in the United States or Canada after September 1, 2019, and installed in either the United States or in Canada.

WARRANTY

Hansgrohe, Inc. warrants to the original consumer purchaser that hansgrohe and AXOR products will be free from defects in material and workmanship for as long as the original consumer purchaser owns both the product and the home in which the product was originally installed. For commercial purchasers, the warranty period is (a) one (1) year for hansgrohe products and (b) five (5) years for AXOR products, in each case from the date of purchase. The warranty period for products in the Rubbed Bronze, Matte Black and Matte White finishes are three (3) years from the date of purchase. This warranty is non-transferable.

WHAT WE WILL DO

Hansgrohe, Inc., at its option, will replace any product or part of the product that proves defective in workmanship and/or material, under normal installation, use, service and maintenance. If Hansgrohe, Inc. is unable to provide a replacement part or product and repair is not practical or cannot be made in timely fashion, Hansgrohe, Inc. may elect to refund the purchase price in exchange for the return of the defective product. REPAIR OR REPLACEMENT (OR, IN LIMITED CIRCUMSTANCES, REFUND OF THE PURCHASE PRICE) AS PROVIDED UNDER THIS LIMITED WARRANTY IS THE EXCLUSIVE REMEDY OF THE PURCHASER.

WHAT IS NOT COVERED BY THE WARRANTY

Because Hansgrohe, Inc. is unable to control the quality of hansgrohe or AXOR products sold by unauthorized sellers, unless otherwise prohibited by law, this warranty does not cover hansgrohe or AXOR products purchased from unauthorized sellers. Authorized sellers can be found on hansgrohe and AXOR branded websites.

Labor and other expenses for disconnection, deinstallation, or return of the product for warranty service (including but not limited to proper packaging and shipping costs), or for installation or reinstallation of the product are not covered by this warranty.

Hansgrohe, Inc. shall not be liable for any damage to the product resulting from

- reasonable wear and tear
- outdoor use
- misuse (including use of the product for an unintended application)
- freezing water
- excessive water pressure
- pipe corrosion in the home in which the product is installed
- abuse, neglect or improper or incorrectly performed installation, maintenance or repair, including the use of abrasive or caustic cleaning agents or "no-rinse" cleaning products.

This warranty does not cover: (i) accessories, connected materials and products, or related products not manufactured by Hansgrohe, Inc. (ii) any hansgrohe or AXOR product sold for display purposes or (iii) hansgrohe or AXOR products purchased from unauthorized sellers.

WHAT YOU MUST DO TO OBTAIN WARRANTY SERVICE OR INFORMATION

Contact your retailer, or contact Technical Service at:

Hansgrohe, Inc.
1492 Bluegrass Lakes Parkway
Alpharetta, GA 30004
Toll-free 800-334-0455

In requesting warranty service, you will need to provide:

1. The sales receipt or other evidence of the date and place of purchase.
2. A description of the problem.
3. Delivery of the product or the defective part, postage prepaid and carefully packed and insured, to:

Hansgrohe, Inc.
1492 Bluegrass Lakes Parkway
Alpharetta, GA 30004
Toll-free 800-334-0455

When warranty service is completed, any repaired or replacement product or part will be returned to you postage prepaid.

REVISED SEPTEMBER 1, 2019.

LIMITATION ON DURATION OF IMPLIED WARRANTIES: Some States do not allow limitations on how long an implied warranty lasts, so the below limitations may not apply to you. TO THE MAXIMUM EXTENT PERMITTED BY APPLICABLE LAW, ANY IMPLIED WARRANTY, INCLUDING THE IMPLIED WARRANTIES OF MERCHANTABILITY AND OF FITNESS FOR A PARTICULAR PURPOSE, IS LIMITED TO THE STATUTORY PERIOD OR THE DURATION OF THIS WARRANTY, WHICHEVER IS SHORTER.

LIMITATION OF SPECIAL, INCIDENTAL OR CONSEQUENTIAL DAMAGES: Some States do not allow the exclusion or limitation of incidental or consequential damages, so the below limitations and exclusions may not apply to you. TO THE MAXIMUM EXTENT PERMITTED BY APPLICABLE LAW, THIS WARRANTY DOES NOT COVER, AND HANSGROHE, INC. SHALL NOT BE LIABLE FOR, ANY SPECIAL, INCIDENTAL OR CONSEQUENTIAL DAMAGES (INCLUDING LABOR CHARGES TO REPAIR, REPLACE, INSTALL OR REMOVE THIS PRODUCT), WHETHER ARISING OUT OF BREACH OF ANY EXPRESS OR IMPLIED WARRANTY, BREACH OF CONTRACT, TORT, OR OTHERWISE. HANSGROHE, INC. SHALL NOT BE LIABLE FOR ANY DAMAGE TO THE PRODUCT RESULTING FROM REASONABLE WEAR AND TEAR, OUTDOOR USE, MISUSE (INCLUDING USE OF THE PRODUCT FOR AN UNINTENDED APPLICATION), FREEZING WATER, EXCESSIVE WATER PRESSURE, PIPE CORROSION IN THE HOME IN WHICH THE PRODUCT IS INSTALLED, ABUSE, NEGLECT OR IMPROPER OR INCORRECTLY PERFORMED INSTALLATION, MAINTENANCE

OR REPAIR, INCLUDING THE USE OF ABRASIVE OR CAUSTIC CLEANING AGENTS OR "NO-RINSE" CLEANING PRODUCTS.

NOTICE TO RESIDENTS OF THE STATE OF NEW JERSEY:

The provisions of this warranty, including its limitations, are intended to apply to the fullest extent permitted by the laws of the State of New Jersey.

This warranty gives you specific legal rights, and you may also have other rights which vary from state to state.

PRODUCT INSTRUCTIONS AND QUESTIONS

Upon purchase or prior to installation, please carefully inspect your product for any damage or visible defect. Prior to installing, always carefully study the enclosed instructions on the proper installation and the care and maintenance of this product.

If you have questions at any time about the use, installation or performance of your product, or the Limited Warranty, please write us or call us toll-free at 800-334-0455.

AXOR

www.divapor.com

AXOR / Hansgrohe, Inc.
1490 Bluegrass Lakes Parkway
Alpharetta, GA 30004
Tel. 800-334-0455
Fax 770-889-1783

axor-design.com