

<b>DE</b>	Gebrauchsanleitung / Montageanleitung	<b>2</b>
<b>FR</b>	Mode d'emploi / Instructions de montage	<b>3</b>
<b>EN</b>	Instructions for use / Assembly instructions	<b>4</b>
<b>IT</b>	Istruzioni per l'uso / Istruzioni per Installazione	<b>5</b>
<b>ES</b>	Modo de empleo / Instrucciones de montaje	<b>6</b>
<b>NL</b>	Gebruiksaanwijzing / Handleiding	<b>7</b>
<b>DK</b>	Brugsanvisning / Monteringsvejledning	<b>8</b>
<b>PT</b>	Instruções para uso / Manual de Instalação	<b>9</b>
<b>PL</b>	Instrukcja obsługi / Instrukcja montażu	<b>10</b>
<b>CS</b>	Návod k použití / Montážní návod	<b>11</b>
<b>SK</b>	Návod na použitie / Montážny návod	<b>12</b>
<b>ZH</b>	用户手册 / 组装说明	<b>13</b>
<b>RU</b>	Руководство пользователя / Инструкция по монтажу	<b>14</b>
<b>FI</b>	Käyttöohje / Asennusohje	<b>15</b>
<b>SV</b>	Bruksanvisning / Monteringsanvisning	<b>16</b>
<b>LT</b>	Vartotojo instrukcija / Montavimo instrukcijos	<b>17</b>
<b>HR</b>	Upute za uporabu / Uputstva za instalaciju	<b>18</b>
<b>RO</b>	Manual de utilizare / Instrucțiuni de montare	<b>19</b>
<b>EL</b>	Οδηγίες χρήσης / Οδηγία συναρμολόγησης	<b>20</b>
<b>SL</b>	Navodilo za uporabo / Navodila za montažo	<b>21</b>
<b>ET</b>	Kasutusjuhend / Paigaldusjuhend	<b>22</b>
<b>LV</b>	Lietošanas pamācība / Montāžas instrukcija	<b>23</b>
<b>SR</b>	Uputstvo za upotrebu / Uputstvo za montažu	<b>24</b>
<b>NO</b>	Bruksanvisning / Montasjeveiledning	<b>25</b>
<b>BG</b>	Инструкция за употреба / Ръководство за монтаж	<b>26</b>
<b>JP</b>	取扱説明書 / 施工説明書	<b>27</b>
<b>SQ</b>	Udhëzuesi i përdorimit / Udhëzime rreth montimit	<b>28</b>
<b>AR</b>	دليل الاستخدام / تعليمات التجميع	<b>29</b>
<b>TR</b>	Kullanım kılavuzu / Montaj kılavuzu	<b>30</b>
<b>HU</b>	Használati útmutató / Szerelési útmutató	<b>32</b>
<b>HE</b>	הוראות שימוש / הוראות הרכבה	<b>34</b>

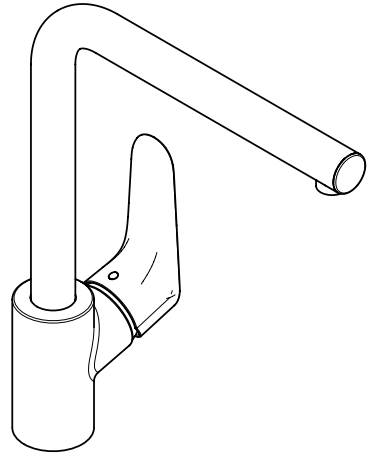

**Focus M41 280 1jet**

31817XXX

**Focus M41 280 Eco 1jet**

31827XXX

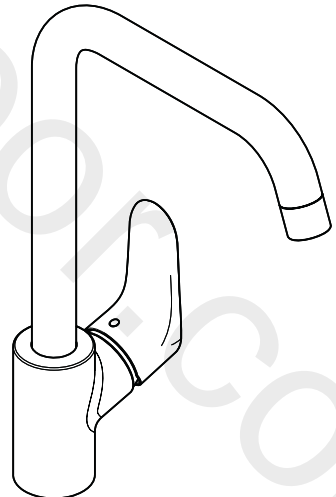

**Focus M41 260 1jet**

31820XXX / 31834XXX



## Sicherheitshinweise

- ⚠ Bei der Montage müssen zur Vermeidung von Quetsch- und Schnittverletzungen Handschuhe getragen werden.
- ⚠ Große Druckunterschiede zwischen den Kalt- und Warmwasseranschlüssen müssen ausgeglichen werden.

## Montagehinweise

- Vor der Montage muss das Produkt auf Transportschäden untersucht werden. Nach dem Einbau werden keine Transport- oder Oberflächenschäden anerkannt.
- Die Leitungen und die Armatur müssen nach den gültigen Normen montiert, gespült und geprüft werden.
- Die in den Ländern jeweils gültigen Installationsrichtlinien sind einzuhalten.

## Technische Daten

Betriebsdruck: max. 1 MPa  
 Empfohlener Betriebsdruck: 0,1 - 0,5 MPa  
 Prüfdruck: 1,6 MPa  
 (1 MPa = 10 bar = 147 PSI)

Heißwassertemperatur: max. 60°C  
 Thermische Desinfektion: 70°C / 4 min

Das Produkt ist ausschließlich für Trinkwasser konzipiert!

## Symbolerklärung

 Kein essigsäurehaltiges Silikon verwenden!

 **Justierung** (siehe Seite 39)

Einstellen der Warmwasserbegrenzung. In Verbindung mit Durchlauferhitzern ist eine Warmwassersperre nicht zu empfehlen.



**Maße** (siehe Seite 40)

**Durchflussdiagramm**  
(siehe Seite 40)



**Serviceile** (siehe Seite 42)

- XXX = Farbcodierung
- 000 = Chrom
- 130 = Polished Bronze
- 140 = Brushed Bronze
- 330 = Polished Black Chrome
- 340 = Brushed Black Chrome
- 670 = Mattschwarz
- 800 = Edelstahl-Optik
- 950 = Brushed Brass

## Sonderzubehör

(nicht im Lieferumfang enthalten)



Adapter (G<sup>3/8</sup> / G<sup>1/2</sup>)  
 #93395000 (siehe Seite 42)



**Reinigung** (siehe Seite 35)



**Bedienung** (siehe Seite 35)

Hansgrohe empfiehlt, morgens oder nach längeren Stagnationszeiten den ersten halben Liter nicht als Trinkwasser zu verwenden.



**Prüfzeichen** (siehe Seite 44)

Störung	Ursache	Abhilfe
Wenig Wasser	- Luftsprudler verkalkt, verschmutzt	- Luftsprudler reinigen / austauschen
Armatur schwergängig	- Kartusche defekt, verkalkt	- Kartusche austauschen
Armatur tropft	- Kartusche defekt	- Kartusche austauschen
Wasseraustritt im Bereich des Schwenkauslaufes	- O-Ring defekt	- O-Ring austauschen
Wasseraustritt am Befestigungsschaft	- Anschlusschläuche nicht ganz in den Grundkörper eingeschraubt	- Anschlusschläuche von Hand festziehen
	- O-Ring am Anschlusschlauch defekt	- O-Ring austauschen
Zu niedrige Warmwassertemperatur	- Warmwasserbegrenzung falsch eingestellt	- Warmwasserbegrenzung einstellen



## Consignes de sécurité

- ⚠ Lors du montage, porter des gants de protection pour éviter toute blessure par écrasement ou coupure.
- ⚠ Il est conseillé d'équilibrer les pressions de l'eau chaude et froide.

## Instructions pour le montage

- Avant son montage, s'assurer que le produit n'a subi aucun dommage pendant le transport. Après le montage, tout dommage de transport ou de surface ne pourra pas être reconnu.
- Les conduites et la robinetterie doivent être montés, rincés et contrôlés selon les normes en vigueur.
- Les directives d'installation en vigueur dans le pays concerné doivent être respectées.

## Informations techniques

Pression de service autorisée: max. 1 MPa  
 Pression de service conseillée: 0,1 - 0,5 MPa  
 Pression maximum de contrôle: 1,6 MPa  
 (1 MPa = 10 bar = 147 PSI)

Température d'eau chaude: max. 60°C  
 Désinfection thermique: 70°C / 4 min

Le produit est exclusivement conçu pour de l'eau potable!

## Description du symbole



Ne pas utiliser de silicone contenant de l'acide acétique!



## Etalonnage (voir pages 39)

Réglage de la limitation d'eau chaude. En liaison avec les chauffe-eau, un blocage de l'eau chaude n'est pas recommandable.



## Dimensions (voir pages 40)



## Diagramme du débit (voir pages 40)



## Pièces détachées (voir pages 42)

XXX = Couleurs  
 000 = Chromé  
 130 = Polished Bronze  
 140 = Brushed Bronze  
 330 = Polished Black Chrome  
 340 = Brushed Black Chrome  
 670 = Matt Black  
 800 = Aspect Acier Inox  
 950 = Brushed Brass

## Accessoires en option

(ne fait pas partie de la fourniture)



Adaptateur (G<sup>3/8</sup> / G<sup>1/2</sup>)  
 #93395000 (voir pages 42)



## Nettoyage (voir pages 35)



## Instructions de service (voir pages 35)

Hansgrohe recommande de ne pas utiliser le premier demi-litre le matin ou après une période de stagnation prolongée.



## Classification acoustique et débit (voir pages 44)

Dysfonctionnement	Origine	Solution
Pas assez d'eau	- aérateur entartré ou encrassé	- Nettoyer l'aérateur ou le changer éventuellement
Dureté de fonctionnement	- Cartouche défectueuse, entartrée	- Changer la cartouche
Le mitigeur goutte	- Cartouche défectueuse	- Changer la cartouche
Fuite à l'embase du bec	- Joint torique défectueux	- Changer le joint torique
Fuite à la fixation sous le mitigeur	- Les flexibles de raccordement ne sont pas correctement vissés dans le corps.	- Resserer le flexible à la main.
	- Joint torique sous les flexible de raccords défectueux	- Changer le joint torique
Température d'eau chaude trop basse, pas d'eau froide	- Limiteur de température mal positionné	- Positionner le limiteur de température





## Safety Notes

- △ Gloves should be worn during installation to prevent crushing and cutting injuries.
- △ The hot and cold supplies must be of equal pressures.

## Installation Instructions

- Prior to installation, inspect the product for transport damages. After it has been installed, no transport or surface damage will be honoured.
- The pipes and the fixture must be installed, flushed and tested as per the applicable standards.
- The plumbing codes applicable in the respective countries must be observed.

## Technical Data

Operating pressure: max. 1 MPa  
 Recommended operating pressure: 0,1 - 0,5 MPa  
 Test pressure: 1,6 MPa  
 (1 MPa = 10 bar = 147 PSI)

Hot water temperature: max. 60°C  
 Thermal disinfection: 70°C / 4 min

The product is exclusively designed for drinking water!

## Symbol description



Do not use silicone containing acetic acid!



## Adjustment (see page 39)

To adjust the hot water limiter. Using a hot water limiter in combination with a continuous flow water heater is not recommended.



## Dimensions (see page 40)



## Flow diagram (see page 40)



## Spare parts (see page 42)

XXX = Colors  
 000 = Chrome Plated  
 130 = Polished Bronze  
 140 = Brushed Bronze  
 330 = Polished Black Chrome  
 340 = Brushed Black Chrome  
 670 = Matt Black  
 800 = Stainless Steel Optic  
 950 = Brushed Brass

## Special accessories (order as an extra)



Adapter (G<sup>3/8</sup> / G<sup>1/2</sup>)  
 #93395000 (see page 42)



## Cleaning (see page 35)



## Operation (see page 35)

Hansgrohe recommends not to use as drinking water the first half liter of water drawn in the morning or after a prolonged period of non-use.



## Test certificate (see page 44)

Fault	Cause	Remedy
Insufficient water	- Aerator calcified, dirty	- Clean aerator, replace as necessary
Mixer stiff	- Cartridge defective, calcified	- Exchange cartridge
Mixer dripping	- Cartridge defective	- Exchange cartridge
Water escaping in area of swivel spout	- O-ring defective	- Exchange O-ring
Water escaping at the threaded base	- connection hoses not completely screwed into basic body	- Tighten connection hoses by hand
	- O-ring at the connection hose defective.	- Exchange O-ring
Hot water temperature too low	- Hot water limiter incorrectly set	- Set hot water limiter



## Indicazioni sulla sicurezza

- ⚠ Durante il montaggio, per evitare ferite da schiacciamento e da taglio bisogna indossare guanti protettivi.
- ⚠ Attenzione! Compensare le differenze di pressione tra i collegamenti dell'acqua fredda e dell'acqua calda.

## Istruzioni per il montaggio

- Prima del montaggio è necessario controllare che non ci siano stati danni durante il trasporto. Una volta eseguito il montaggio, non verranno riconosciuti eventuali danni di trasporto o delle superfici.
- Montare, lavare e controllare tubature e rubinetteria rispettando le norme correnti.
- Vanno rispettate le direttive di installazione nazionali vigenti nel rispettivo paese.

## Dati tecnici

Pressione d'uso: max. 1 MPa  
 Pressione d'uso consigliata: 0,1 - 0,5 MPa  
 Pressione di prova: 1,6 MPa

(1 MPa = 10 bar = 147 PSI)

Temperatura dell'acqua calda: max. 60°C

Disinfezione termica: 70°C / 4 min

Il prodotto è concepito esclusivamente per acqua potabile!

## Descrizione simbolo



Non utilizzare silicone contenente acido acetico!



**Taratura** (vedi pagg. 39)

Regolazione del limitatore di erogazione d'acqua calda. Un limitatore di erogazione di acqua calda in combinazione con le caldaie istantanee non è consigliabile.

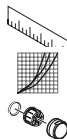

**Ingombri** (vedi pagg. 40)

**Diagramma flusso** (vedi pagg. 40)

**Parti di ricambio** (vedi pagg. 42)

XXX = Trattamento  
 000 = Cromato  
 130 = Polished Bronze  
 140 = Brushed Bronze  
 330 = Polished Black Chrome  
 340 = Brushed Black Chrome  
 670 = Matt Black  
 800 = Acciaio Inox Acciaio  
 950 = Brushed Brass

## Accessori speciali

(non contenuto nel volume di fornitura)



Adattatore (G<sup>3/8</sup> / G<sup>1/2</sup>)  
 #93395000 (vedi pagg. 42)



**Pulitura** (vedi pagg. 35)



**Procedura** (vedi pagg. 35)

Hansgrohe raccomanda, di mattina oppure dopo lunghi tempi di stagnazione, di non utilizzare il primo mezzo litro come acqua potabile.



**Segno di verifica** (vedi pagg. 44)

Problema	Possibile causa	Rimedio
Scarsità d'acqua	- Rompigetto difettoso, pieno di calcare	- Pulire oppure sostituire il rompigetto
Miscelatore duro	- Cartuccia difettosa	- Sostituire la cartuccia
Miscelatore gocciola	- Cartuccia difettosa	- Sostituire la cartuccia
Perdita di acqua intorno all'erogazione girevole	- O-ring difettoso	- Sostituire l'o-ring
Perdita di acqua al set di fissaggio	- I raccordi dei flessibili avvitati male nel corpo incasso	- Avvitare i raccordi flessibili a mano
	- O-ring al raccordo flessibile difettoso	- Sostituire l'o-ring
Temperatura dell'acqua calda	- Limitazione dell'acqua calda regolata male	- Regolare la limitazione dell'acqua calda



## Indicaciones de seguridad

- ⚠ Durante el montaje deben utilizarse guantes para evitar heridas por aplastamiento o corte.
- ⚠ Grandes diferencias de presión en servicio entre agua fría y agua caliente deben equilibrarse.

## Indicaciones para el montaje

- Antes del montaje se debe examinar el producto contra daños de transporte. Después de la instalación no se reconoce ningún daño de transporte o de superficie.
- Los conductos y la grifería deben montarse, lavarse y comprobarse según las normas vigentes.
- Es obligatorio el cumplimiento de las directrices de instalación vigentes en el país respectivo.

## Datos técnicos

Presión en servicio: max. 1 MPa  
 Presión recomendada en servicio: 0,1 - 0,5 MPa  
 Presión de prueba: 1,6 MPa  
 (1 MPa = 10 bar = 147 PSI)

Temperatura del agua caliente: max. 60 °C  
 Desinfección térmica: 70 °C / 4 min

El producto ha sido concebido exclusivamente para agua potable.

## Descripción de símbolos



No utilizar silicona que contiene ácido acético!



## Ajuste (ver página 39)

Ajuste del límite de agua caliente. En combinación con calentadores continuos no es recomendable utilizar un bloqueo de agua caliente.



## Dimensiones (ver página 40)



## Diagrama de circulación

(ver página 40)



## Repuestos (ver página 42)

XXX = Acabados  
 000 = Cromado  
 130 = Polished Bronze  
 140 = Brushed Bronze  
 330 = Polished Black Chrome  
 340 = Brushed Black Chrome  
 670 = Matt Black  
 800 = Acero Especial  
 950 = Brushed Brass

## Opcional (no incluido en el suministro)



Adaptador (G<sup>3/8</sup> / G<sup>1/2</sup>)  
 #93395000 (ver página 42)



## Limpiar (ver página 35)



## Manejo (ver página 35)

Hansgrohe recomienda no utilizar el primer medio litro como agua potable por las mañanas o tras un largo periodo de inactividad.



## Marca de verificación

(ver página 44)

Problema	Causa	Solución
Sale poca agua	- Aireador con cal o sucio	- limpiar / cambiary aireador
Manecilla va dura	- cartucho dañado	- cambiar el cartucho
Grifo pierde agua	- cartucho dañado	- cambiar el cartucho
Pérdida de agua en el caño giratorio	- junta dañado	- cambiar juntas
Pérdida de agua en el set de fijación	- Conexión flexible mal atornillada al cuerpo del caño.	- Apretar a mano la conexión flexible
	- Daños en la junta de la conexión flexible	- cambiar juntas
Temperatura del agua caliente demasiado baja	- tope de agua caliente mal	- ajustar tope





## Veiligheidsinstructies

- ⚠ Bij de montage moeten ter voorkoming van knel- en snijwonden handschoenen worden gedragen.
- ⚠ Grote drukverschillen tussen de koud- en warmwater toevoer dienen vermeden te worden.

## Montage-instructies

- Vóór de montage moet het product gecontroleerd worden op transportschade. Na de inbouw wordt geen transport- of oppervlakteschade meer aanvaard.
- De leidingen en armaturen moeten gemonteerd, gespoeld en gecontroleerd worden volgens de geldige normen.
- De in de overeenkomstige landen geldende installatie-richtlijnen moeten nageleefd worden.

## Technische gegevens

Werkdruk: max. max. 1 MPa  
 Aanbevolen werkdruk: 0,1 - 0,5 MPa  
 Getest bij: 1,6 MPa  
 (1 MPa = 10 bar = 147 PSI)

Temperatuur warm water: max. 60°C  
 Thermische desinfectie: 70°C / 4 min  
 Het product is uitsluitend ontworpen voor drinkwater!

## Symboolbeschrijving



Gebruik geen zuurhoudende silicone!



**Instellen** (zie blz. 39)

Instellen van de warmwaterbegrenzing. In combinatie met een doorstromer is een warmwaterblokkering niet aanbevelenswaardig.



**Maten** (zie blz. 40)



**Doorstroomdiagram** (zie blz. 40)

**Service onderdelen** (zie blz. 42)

XXX = Kleuren  
 000 = Verchroomd  
 130 = Polished Bronze  
 140 = Brushed Bronze  
 330 = Polished Black Chrome  
 340 = Brushed Black Chrome  
 670 = Matt Black  
 800 = RVS-look  
 950 = Brushed Brass

## Toebehoren

(behoort niet tot het leveringspakket)



Adapter (G<sup>3/8</sup> / G<sup>1/2</sup>)  
 #93395000 (zie blz. 42)



**Reinigen** (zie blz. 35)



**Bediening** (zie blz. 35)

Hansgrohe raadt aan om 's morgens na langere stagnatietijden de eerste halve liter niet als drinkwater te gebruiken.



**Keurmerk** (zie blz. 44)

Storing	Oorzaak	Oplossing
Weinig water	- Perlator verstopt	- Perlator reinigen / uitwisselen
Bediening zwaar	- Kardoes defect of verkalkt	- Kardoes uitwisselen
Mengkraan lekt	- Kardoes defect	- Kardoes uitwisselen
Lekkage tussen aansluiting uitloop en kraanhuis	- O-ring defect	- O-ring uitwisselen
Lekkage op montageschacht	- Aansluitslangen niet geheel in kraanhuis vastgedraaid	- Aansluitslangen handvast aandraaien
	- O-ring van aansluitslang defect	- O-ring uitwisselen
Temperatuur van warm water te laag	- Heetwaterbegrenzer verkeerd ingesteld	- Heetwaterbegrenzer instellen



## Sikkerhedsanvisninger

- ⚠ Ved monteringen skal der bruges handsker for at undgå kvæstelser og snitsår.
- ⚠ Større trykforskelte mellem koldt og varmt vand bør udjævnes.

## Monteringsanvisninger

- Før monteringen skal produktet kontrolleres for transportskader. Efter monteringen godkendes transportskader eller skader på overfladen ikke længere.
- Ledningerne og armaturerne skal monteres, skylles og kontrolleres iht. de gældende standarder.
- Installationsbestemmelserne, der gælder i det enkelte land, skal overholdes.

## Tekniske data

Driftstryk: max. 1 MPa  
 Anbefalet driftstryk: 0,1 - 0,5 MPa  
 Prøvetryk: 1,6 MPa  
 (1 MPa = 10 bar = 147 PSI)

Varmvandstemperatur: max. 60°C  
 Termisk desinfektion: 70°C / 4 min

Produktet er udelukkende beregnet til drikkevand!

## Symbolbeskrivelse



Der må ikke benyttes eddikesyreholdig silikone!



## Forindstilling (se s. 39)

Indstilling af varmvandsbegrænsningen. I forbindelse med gennemstrømningsvandvarmere anbefaler vi ikke en varmvandsspærre.



## Målene (se s. 40)



## Gennemstrømningsdiagram

(se s. 40)



## Reserve dele (se s. 42)

XXX = Overflade  
 000 = Krom  
 130 = Polished Bronze  
 140 = Brushed Bronze  
 330 = Polished Black Chrome  
 340 = Brushed Black Chrome  
 670 = Matt Black  
 800 = Stainless Steel Optic  
 950 = Brushed Brass

## Specialtilbehør (ikke med i leveringsomfang)



Adapter (G<sup>3/8</sup> / G<sup>1/2</sup>)  
 #93395000 (se s. 42)



## Rengøring (se s. 35)



## Brugsanvisning (se s. 35)

Hansgrohe anbefaler at den første halve liter om morgenen eller efter længere stagneringstider ikke anvendes som drikkevand.



## Godkendelse (se s. 44)

Fejl	Årsag	Hjælp
For lidt vand	- Tilkalket/snavset perlator	- Rengør / udskift perlator
Grebet går trægt	- Kartusche defekt, tilkalket	- Udskift kartusche
Armaturet drypper	- Defekt kartusche	- Udskift kartusche
Armaturet drypper ved svingtuden.	- Defekt o-ring	- Udskift o-ring
Armaturet er utæt ved befæstelsesdelene	- Tilslutningsslangerne er ikke skruet korrekt op i armaturet. - Defekt o-ring på tilslutningsslange	- Med håndkraft skures tilslutningsslangen strammere på. - Udskift o-ring
For lav varmvands-temperatur	- Varmvandsbegrænsningen er forkert indstillet	- Indstil varmvandsbegrænsningen



## Avisos de segurança

- ⚠ Durante a montagem devem ser utilizadas luvas de protecção, de modo a evitar ferimentos resultantes de entalamentos e de cortes.
- ⚠ Grandes diferenças entre as pressões das águas quente e fria devem ser compensadas.

## Avisos de montagem

- Antes da montagem deve-se controlar o produto relativamente a danos de transporte. Após a montagem não são aceites quaisquer danos de transporte ou de superfície.
- As tubagens e a torneira têm que ser montadas, enxaguadas e verificadas de acordo com as normas em vigor.
- A prescrições de instalação válidas nos respetivos países devem ser respeitadas.

## Dados Técnicos

Pressão de funcionamento:	max. 1 MPa
Pressão de func. recomendada:	0,1 - 0,5 MPa
Pressão testada:	1,6 MPa (1 MPa = 10 bar = 147 PSI)
Temperatura da água quente:	max. 60 °C
Desinfecção térmica:	70 °C / 4 min

Este produto foi única e exclusivamente concebido para água potável!

## Descrição do símbolo



Não utilizar silicone que contenha ácido acético!



## Afinação (ver página 39)

Ajuste do limitador de água quente. Em combinação com um esquentador, não é recomendável o uso de um bloqueio de água quente.



## Medidas (ver página 40)



## Fluxograma (ver página 40)



## Peças de substituição

(ver página 42)

XXX = Acabamentos
000 = Cromado
130 = Polished Bronze
140 = Brushed Bronze
330 = Polished Black Chrome
340 = Brushed Black Chrome
670 = Matt Black
800 = Aço Imaculado Ótica
950 = Brushed Brass

## Acessórios especiais

(não incluído no volume de fornecimento)



Adaptador (G<sup>3/8</sup> / G<sup>1/2</sup>)  
#93395000 (ver página 42)



## Limpeza (ver página 35)



## Funcionamento (ver página 35)

A Hansgrohe recomenda a não utilização do primeiro meio litro de água, de manhã ou após longas paragens, para fins de consumo.



## Marca de controlo (ver página 44)

Falha	Causa	Solução
Água insuficiente	- Emulsor sujo	- Limpar / trocar o emulsor
Misturadora perra	- Cartucho defeituoso, calcificado	- Substituir o cartucho
Misturadora a pingar	- Cartucho defeituoso	- Substituir o cartucho
Perde água na zona da bica rotativa	- O-ring defeituoso	- Trocar o-ring
Perde água pela base roscada	- Tubos de ligação não estão completamente enroscados	- Apertar os tubos de ligação à mão
	- O-ring dos tubo de ligação defeituoso	- Trocar o-ring
Temperatura da água quente muito baixa	- O limitador de temperatura está incorrectamente colocado	- Regular o limitador de temperatura



## Wskazówki bezpieczeństwa

- ⚠ Aby uniknąć zranień na skutek zgniecenia lub przecięcia, podczas montażu należy nosić rękawice ochronne.
- ⚠ Znaczne różnice ciśnień na dopływach ciepłej i zimnej wody muszą zostać wyrównane.

## Wskazówki montażowe

- Przed montażem należy skontrolować produkt pod kątem szkód transportowych. Po montażu nie widać żadnych szkód transportowych ani szkód na powierzchni.
- Przewody i armatura muszą być montowane, płukane i kontrolowane według obowiązujących norm.
- Należy przestrzegać wytycznych instalacyjnych obowiązujących w danym kraju.

## Dane techniczne

Ciśnienie robocze:	maks. 1 MPa
Zalecane ciśnienie robocze:	0,1 - 0,5 MPa
Ciśnienie próbne:	1,6 MPa
	(1 MPa = 10 bary = 147 PSI)
Temperatura wody gorącej:	maks. 60°C
Dezynfekcja termiczna:	70°C / 4 min
Produkt przeznaczony wyłącznie do wody pitnej!	

## Opis symbolu



Nie stosować silikonów zawierających kwas octowy!



**Ustawianie** (patrz strona 39)

Ustawianie ogranicznika ciepłej wody. Używanie ogranicznika temperatury wody w połączeniu z przepływowym podgrzewaczem wody nie jest zalecane.



**Wymiary** (patrz strona 40)

**Schemat przepływu**  
(patrz strona 40)



**Części serwisowe** (patrz strona 42)

XXX =	Kody kolorów
000 =	Chrom
130 =	Polished Bronze
140 =	Brushed Bronze
330 =	Polished Black Chrome
340 =	Brushed Black Chrome
670 =	Matt Black
800 =	Stal Szlachetna
950 =	Brushed Brass

## Wyposażenie specjalne

(Nie jest częścią dostawy)



Prześciółka (G<sup>3/8</sup> / G<sup>1/2</sup>)  
#93395000 (patrz strona 42)



**Czyszczenie** (patrz strona 35)



**Obsługa** (patrz strona 35)

Hansgrohe zaleca, by z rana lub po dłuższym czasie niekorzystania, pierwsze pół litra wody nie używać jako wody pitnej.



**Znak jakości** (patrz strona 44)

Usterka	Przyczyna	Pomoc
Mała ilość wody	- Napowietrzacz zakamieniony, zabrudzony	- Oczyszczyć / wymienić napowietrzacz
Uchwyt armatury pracuje z wysiłkiem	- Uszkodzony wkład, zakamieniony	- Wymiana wkładu
Armatura cieknie	- Uszkodzony wkład	- Wymiana wkładu
Wyciek wody w obszarze wylewki	- Uszkodzony o-ring	- Wymienić o-ring
Wyciek wody przy mocowaniu od dołu	- Zbyt słabo wkręcone wężyki w korpus - Uszkodzony o-ring przy wężu przyłączeniowym	- Dokręcić wężyki - Wymienić o-ring
Za niska temperatura ciepłej wody	- Niewłaściwe ustawienie ogranicznik	- Ustawić ogranicznik ciepłej wody



## Bezpečnostní pokyny

- ⚠ Pro zabránění řezným zraněním a pohmožděninám je nutné při montáži nosit rukavice.
- ⚠ Je nutné vyrovnat velké rozdíly tlaku mezi přípoji studené a teplé vody.

## Pokyny k montáži

- Před montáží je třeba produkt zkontrolovat, zda nebyl při transportu poškozen. Po zabudování nebudou uznány žádné škody způsobené transportem nebo poškození povrchu.
- Vedení a armatura musí být namontovány, propláchnuty a otestovány podle platných norem.
- Je třeba dodržovat montážní pravidla platná v dané zemi.

## Technické údaje

Provozní tlak: max. 1 MPa  
 Doporučený provozní tlak: 0,1 - 0,5 MPa  
 Zkušební tlak: 1,6 MPa  
 (1 MPa = 10 bar = 147 PSI)

Teplota horké vody: max. 60 °C  
 Tepelná desinfekce: 70 °C / 4 min

Výrobky Hansgrohe jsou vhodné pro přímý kontakt s pitnou vodou.

## Popis symbolů

 Nepoužívat silikon s obsahem kyseliny octové!

## Nastavení (viz strana 39)

Nastavení omezovače teplé vody. Ve spojení s průtokovým ohřívačem se použití uzávěru teplé vody nedoporučuje.

## Rozměry (viz strana 40)



## Diagram průtoku (viz strana 40)



## Servisní díly (viz strana 42)

XXX = Kód povrchové úpravy  
 000 = Chrom  
 130 = Polished Bronze  
 140 = Brushed Bronze  
 330 = Polished Black Chrome  
 340 = Brushed Black Chrome  
 670 = Matt Black  
 800 = Nerezová Ocel  
 950 = Brushed Brass

## Zvláštní příslušenství

(není součástí dodávky)



Adaptér (G<sup>3</sup>/<sub>8</sub> / G<sup>1</sup>/<sub>2</sub>)  
 #93395000 (viz strana 42)



Čištění (viz strana 35)



Ovládání (viz strana 35)

Hansgrohe doporučuje ráno nebo po delších přestávkách nepoužívat prvního půl litru jako pitnou vodu.



Zkušební značka (viz strana 44)

Porucha	Příčina	Odstranění
Málo vody	- perláro zanesen vodním kamenem, znečištěn	- vyčistit / vyměnit perlátor
Armatura jde ztěžka	- Kartuše je vadná, zanesená vodním kamenem	- Kartuši vyměnit
Armatura odkapává	- Kartuše je vadná	- Kartuši vyměnit
výstup vody v rozsahu otočného výtoku	- O-kroužek je defektní	- vyměnit O-kroužek
výstup vody na upevňovacím násadci	- přípojovací hadice nejsou dostatečně zašroubovány do tělesa - O-kroužek na přípojovací hadici je defektní	- přípojovací hadice utáhnout rukou - vyměnit O-kroužek
Nízká teplota teplé vody	- Špatně nastavená zarážka pro teplou vodu	- Seřídít zarážku pro teplou vodu



## Bezpečnostné pokyny

- ⚠ Pri montáži musíte nosiť rukavice, aby ste predišli pomliaždeninám a rezným poraneniam.
- ⚠ Veľké rozdiely v tlaku medzi prípojkami studenej a teplej vody musia byť vyrovnané.

## Pokyny pre montáž

- Pred montážou musíte produkt skontrolovať, či nebol počas transportu poškodený. Po zabudovaní nebudú uznané žiadne škody spôsobené transportom alebo poškodenia povrchu.
- Potrubia a vybavenie musia byť namontované, prepláchnuté a vybavené v platnom normami.
- Je potrebné dodržiavať smernice o inštalácii, ktoré sú práve teraz platné v krajinách.

## Technické údaje

Prevádzkový tlak:	max. 1 MPa
Doporučený prevádzkový tlak:	0,1 - 0,5 MPa
Skúšobný tlak:	1,6 MPa (1 MPa = 10 bar = 147 PSI)
Teplota teplej vody:	max. 60°C
Termická dezinfekcia:	70°C / 4 min
Výrobok je koncipovaný výhradne pre pitnú vodu!	

## Popis symbolov



Nepoužívať silikón s obsahom kyseliny octovej!



## Nastavenie (viď strana 39)

Nastavenie obmedzenia teplej vody. V spojení s prietokovými ohrievačmi sa neodporúča použitie obmedzovača teplej vody.



## Rozmery (viď strana 40)



## Diagram prietoku (viď strana 40)



## Servisné diely (viď strana 42)

XXX	= Farebné označenie
000	= Chróm
130	= Polished Bronze
140	= Brushed Bronze
330	= Polished Black Chrome
340	= Brushed Black Chrome
670	= Matt Black
800	= Ušľachtilá Oceľ
950	= Brushed Brass

## Zvláštne príslušenstvo

(nie je súčasťou dodávky)



Adaptér (G<sup>3/8</sup> / G<sup>1/2</sup>)  
#93395000 (viď strana 42)



## Čistenie (viď strana 35)



## Obsluha (viď strana 35)

Hansgrohe odporúča ráno a po dlhších dobách odstávky nepoužiť prvého pol litra vody ako pitnú vodu.



## Osvedčenie o skúške (viď strana 44)

Porucha	Príčina	Pomoc
Málo vody	- Perlátor zanesený vodným kameňom	- Vyčistiť alebo vymeniť perlátor
Armatúra "chodí" ťažko	- Kartuša je poškodená, vápenaté usadeniny	- Vymeniť kartušu
Z armatúry kvapká voda	- Kartuša je poškodená	- Vymeniť kartušu
Uhajanie vode ob vrtľivem izlivu	- Chybný O krúžok	- Vymeniť O krúžok
Uhajanie vode ob pritrďilnem nastavku	- Hadice pripojenia nie sú celkom zaskrutkované do základného telesa - Chybný O krúžok na pripojovacej hadici	- Hadice pripojenia dotiahnuť ručne - Vymeniť O krúžok
Nízka teplota teplej vody	- Nesprávne nastavená zarážka na	- Nastavenie zarážky na teplú vodu



**安全技巧**

- △ 装配时为避免挤压和切割受伤, 必须戴上手套.
- △ 冷热水管间过大的压力差必须予以平衡.

**安装提示**

- 安装前必须检查产品是否受到运输损害. 安装后将不认可运输损害或表面损伤.
- 管道和阀门必须根据通用标准进行安装, 冲洗和检查.
- 请遵守当地国家现行的安装规定.

**技术参数**

工作压力:	最大 1 MPa
推荐工作压力:	0,1 - 0,5 MPa
测试压强:	1,6 MPa (1 MPa = 10 bar = 147 PSI)
热水温度:	最大 60°C
热力消毒:	70°C / 4 分钟

该产品专为饮用水设计!

**符号说明**

 请勿使用含有乙酸的硅胶!

 **调节** (参见第页 39)

热水温度调节. 如果使用即热式喷头, 则不建议安装热水阀门.

 **大小** (参见第页 40)

 **流量示意图** (参见第页 40)

**备用零件** (参见第页 42)

XXX =	颜色代码
000 =	镀铬
130 =	Polished Bronze
140 =	Brushed Bronze
330 =	Polished Black Chrome
340 =	Brushed Black Chrome
670 =	Mat Black
800 =	不锈钢表面
950 =	Brushed Brass

**选装附件** (不在供货范围内)

 转接器 (G $\frac{3}{8}$  / G $\frac{1}{2}$ )  
#93395000 (参见第页 42)

 **清洗** (参见第页 35)

 **操作** (参见第页 35)

汉斯格雅建议, 清晨或在水流长时间停滞后, 前半升水不作饮用水使用.

 **检验标记** (参见第页 44)

问题	原因	补救
龙头出水量小	- 起泡器结垢, 脏污	- 检查起泡器, 视需要更换
龙头不灵活	- 阀芯损坏, 结垢	- 更换阀芯
龙头滴水	- 阀芯损坏	- 更换阀芯
水从龙头出水嘴流出	- O形环损坏	- 更换O形环
水从螺纹底座中流出	- 连接软管没有完全旋入基体 - 连接软管的O形环损坏	- 用手拧紧连接软管 - 更换O形环
热水温度过低	- 温度限制器设置错误	- 设置温度限制器



## Указания по технике безопасности

- Во время монтажа следует надеть перчатки во избежание прищемления и порезов.
- донного клапа. Перед установкой смесителя необходимо регулировочными кранами выровнять авление холодной и горячей воды при помощи вентилей регулирующих подачу воды в квартиру.

## Указания по монтажу

- Перед монтажом следует проверить изделие на предмет повреждений при перевозке. После монтажа претензии о возмещении ущерба за повреждения при перевозке или повреждения поверхностей не принимаются.
- Трубы и арматура должны быть установлены, промыты и проверены в соответствии с действующими нормами.
- Необходимо соблюдать требования по монтажу, действующие в соответствующих странах.

## Технические данные

Рабочее давление: не более 1 МПа  
 Рекомендуемое рабочее давление: 0,1 - 0,5 МПа  
 Давления: 1,6 МПа  
 (1 МПа = 10 bar = 147 PSI)  
 Температура горячей воды: не более 60 °C  
 Термическая дезинфекция: 70 °C / 4 мин  
 Изделие предназначено исключительно для питьевой воды!

## Описание символов



Не применяйте силикон, содержащий уксусную кислоту.



## Подгонка (см. стр. 39)

Регулировка ограничителя горячей воды. В сочетании с проточными нагревателями не рекомендуется использовать блокировку воды.



## Размеры (см. стр. 40)



## Схема потока (см. стр. 40)



## Комплект (см. стр. 42)

XXX = Цветная кодировка  
 000 = Хром  
 130 = Polished Bronze  
 140 = Brushed Bronze  
 330 = Polished Black Chrome  
 340 = Brushed Black Chrome  
 670 = Matt Black  
 800 = Сталь  
 950 = Brushed Brass

## Специальные принадлежности

(не включено в объем поставки!)



Переходник (G<sup>3</sup>/<sub>8</sub> / G<sup>1</sup>/<sub>2</sub>)  
 #93395000 (см. стр. 42)



## Очистка (см. стр. 35)



## Эксплуатация (см. стр. 35)

Hansgrohe рекомендует по утрам либо после длительного перерыва в использовании не использовать первые поллитра воды для питья.



## Знак технического контроля (см. стр. 44)

Неисправность	Причина	Устранение неисправности
недостаточный давление (если устан напор воды)	- Аэратор засорен накипью, загрязнен	- Очистите / замените аэратор
Арматура работает с усилием	- Картридж неисправен, засорение накипью	- Замените картридж
Арматура протекает	- Картридж неисправен	- Замените картридж
Выход воды в области поворотного выхода	- Уплотнительное кольцо круглого сечения неисправно	- Замените уплотнительное кольцо круглого сечения
Выход воды у основания крепления	- Шланги подключения не полностью завернуты в корпус	- Затяните шланги подключения вручную
	- Уплотнительное кольцо круглого сечения на соединительном шланге неисправно	- Замените уплотнительное кольцо круглого сечения
Температура горячей воды слишком низкая	- Ограничение горячей воды отрегулировано неправильно	- Отрегулируйте ограничение горячей воды



**Turvallisuusohjeet**

- △ Asennuksessa on käytettävä käsiineitä puristumien ja viiltojen aiheuttamien tapaturmien estämiseksi.
- △ Suuret paine-erot kylmä- ja kuumavesiliitäntöjen välillä on tasattava.

**Asennusohjeet**

- Ennen asennusta on tarkastettava tuotteen mahdolliset kuljetusvahingot. Asennuksen jälkeen kuljetus- ja pintavaurioita ei hyväksytä.
- Putket ja hana on asennettava, huuhdeltava ja tarkastettava voimassa olevien standardien mukaisesti.
- Jokaisessa maassa on noudatettava siellä päteviä asennusohjeita.

**Tekniset tiedot**

Käyttöpainne: maks. 1 MPa  
 Suositeltu käyttöpainne: 0,1 - 0,5 MPa  
 Koestuspainne: 1,6 MPa

(1 MPa = 10 bar = 147 PSI)

Kuuman veden lämpötila: maks. 60 °C  
 Lämpödesinfektio: 70 °C / 4 min

Tuote on suunniteltu käytettäväksi ainoastaan juomaveden kanssa!

**Merkin kuvaus**

Älä käytä etikkahappopitoista silikonia!



**Säätö** (katso sivu 39)

Lämpötilan rajoittimen säätäminen. Emme suosittele käyttämään lämpötilan rajoitinta vedenlämmittimen (läpivirtauskuumennin) yhteydessä.



**Mitat** (katso sivu 40)



**Virtausdiagrammi** (katso sivu 40)

Häiriö	Syy	Toimenpide
Vähän vettä	- Poresuutin kalkkeutunut, likaantunut	- Puhdista / vaihda poresuutin
Hana on raskaskäyttöinen	- Patruuna rikki, kalkkikerrostumia	- Vaihda patruuna
Hanasta tippuu vettä	- Patruuna rikki	- Vaihda patruuna
Vettä valuu kääntyvän juoksuputken juuresta	- O-renkas on rikki	- Vaihda O-renkas
Vettä valuu kiinnityskauluksesta	- Liitosletkut eivät ole kierretty kiinni perusrunkoon pohjaan asti - Liitosletkun O-renkas on rikki	- Kierrä liitosletkut kiinni käsikireyteen - Vaihda O-renkas
Lämminveden lämpötila liian alhainen	- Lämminveden rajoitin väärin säädetty	- Säädä lämminveden rajoitin



**Varaosat** (katso sivu 42)

XXX = Värikoodaus  
 000 = Kromi  
 130 = Polished Bronze  
 140 = Brushed Bronze  
 330 = Polished Black Chrome  
 340 = Brushed Black Chrome  
 670 = Matt Black  
 800 = Inox-Optinen  
 950 = Brushed Brass

**Erityisvaruste** (ei kuulu toimitukseen)



Sovitin (G<sup>3/8</sup> / G<sup>1/2</sup>)  
 #93395000 (katso sivu 42)



**Puhdistus** (katso sivu 35)



**Käyttö** (katso sivu 35)

Hansgrohe suosittelee, että ensimmäistä puolta litraa ei käytetä juomavetenä aamuisin eikä silloin, kun laitetta ei ole käytetty pitkään aikaan.



**Koestusmerkki** (katso sivu 44)



## Säkerhetsanvisningar

- △ Handskar ska bäras under monteringsarbetet så att man kan undvika kläm- och skärskador.
- △ Stora tryckskillnader mellan anslutningarna för varmt och kallt vatten måste utjämnas.

## Monteringsanvisningar

- Det måste undersökas om produkten har transportskador innan den monteras. Efter monteringen accepteras inga transport- eller ytskiktsskador.
- Ledningarna och blandaren måste monteras, spolats igenom och kontrolleras enligt de gällande normerna.
- De installationsriktlinjer som gäller i länderna ska följas.

## Tekniska data

Driftstryck:	max. 1 MPa
Rek. driftstryck:	0,1 - 0,5 MPa
Tryck vid provtryckning:	1,6 MPa (1 MPa = 10 bar = 147 PSI)
Varmvattentemperatur:	max. 60 °C
Termisk desinfektion:	70 °C / 4 min
Produkten är enbart avsedd för dricksvatten!	

## Symbolförklaring

 Använd inte silikon som innehåller ättiksyra!

 **Justering** (se sidan 39)

Ställa in varmvattenregleringen. Tillsammans med varmvattenberedare rekommenderas inte en varmvattenspärr.

 **Måtten** (se sidan 40)

 **Flödesschema** (se sidan 40)

 **Reservdelar** (se sidan 42)

XXX	= Färgkodning
000	= Krom
130	= Polished Bronze
140	= Brushed Bronze
330	= Polished Black Chrome
340	= Brushed Black Chrome
670	= Matt Black
800	= Rostfri-Optik
950	= Brushed Brass

**Specialtillbehör** (medföljer ej leveransen)

 Adapter (G<sup>3</sup>/<sub>8</sub> / G<sup>1</sup>/<sub>2</sub>)  
#93395000 (se sidan 42)

 **Rengöring** (se sidan 35)

 **Hantering** (se sidan 35)

Hansgrohe rekommenderar att den första halvlitern inte används som dricksvatten på morgonen eller efter längre perioder utan användning.

 **Testsigill** (se sidan 44)

Störning	Orsak	Åtgärd
För lite vatten	- Areator är täckt av kalk, smutsig	- Rengör / byt areator
Blandare är trög	- Patron defekt, förkalkad	- Byt ut patron
Blandare droppar	- Patron defekt	- Byt ut patron
Vatten kommer ut vid den svängbara blandaren	- O-ring defekt	- Byt ut O-ring
Vatten kommer ut vid monteringsstaget	- Anslutningsslangar inte helt inskruvade i grundkonstruktionen	- Drag fast anslutningsslangar för hand.
	- O-ring på anslutningsslang defekt	- Byt ut O-ring
Varmvattentemperaturen är för låg	- Varmvattenreglering felaktigt inställd	- Ställ in varmvattenreglering



## Saugumo technikos nurodymai

- ⚠️ Apsaugai nuo užspaudimo ir įsijovimo montavimo metu mūvėkite pirštines.
- ⚠️ Turi būti išlyginti šalto ir karšto slėgio nelygumai.

## Montavimo instrukcija

- Prieš montuojant būtina patikrinti, ar gaminys nebuvo pažeistas transportavimo metu. Sumontavus pretenzijos dėl transportavimo ir paviršiaus pažeidimų nepriimamos.
- Vamzdžiai ir sujungimai turi būti montuojami, plaunami ir tikrinami pagal galiojančias normas.
- Laikykitės atitinkamoje šalyje galiojančių direktyvų dėl įrengimo.

## Techniniai duomenys

Darbinis slėgis: ne daugiau kaip 1 MPa  
 Rekomenduojamas slėgis: 0,1 - 0,5 MPa  
 Bandomasis slėgis: 1,6 MPa  
 (1 MPa = 10 barų = 147 PSI)

Karšto vandens temperatūra: ne daugiau kaip 60 °C  
 Terminis dezinfekavimas: 70 °C / 4 min

Produktas skirtas tik geriamajam vandeniui!

## Simbolio aprašymas



Nenaudokite silikono, kurio sudėtyje yra acto rūgšties!



## Reguliavimas (žr. psl. 39)

Karšto vandens ribojimas. Kartu su cirkuliaciniais šildytuvais nerekomenduojama naudoti karšto vandens blokavimo įtaisų.



## Išmatavimai (žr. psl. 40)



## Pralaidumo diagrama (žr. psl. 40)

## Atsarginės dalys (žr. psl. 42)

XXX = Spalvos  
 000 = Chrom  
 130 = Polished Bronze  
 140 = Brushed Bronze  
 330 = Polished Black Chrome  
 340 = Brushed Black Chrome  
 670 = Matt Black  
 800 = Plienas  
 950 = Brushed Brass

## Specialūs priedai (nėra pridedama)



Adapteris (G<sup>3/8</sup> / G<sup>1/2</sup>)  
 #93395000 (žr. psl. 42)



## Valymas (žr. psl. 35)



## Eksploatacija (žr. psl. 35)

Naudojant po ilgesnės pertraukos, „Hansgrohe“ rekomenduoja pirmo pusės litro vandens nevertoti kaip geriamojo.



## Bandymo pažyma (žr. psl. 44)

Gedimas	Priežastis	Priemonė
Per maža srovė	- Perlatorius apkalkėjęs, užsikimšęs	- Perlatorių išvalyti / pakeisti
Sunkiai sukiojama rankenėlė	- Kasetė pažeista, užkalkėjusi	- Pakeisti kasetę
Maišytuvus praleidžia vandenį	- Kasetė pažeista	- Pakeisti kasetę
Prateka vanduo po čiaupu	- tarpinė pažeista	- tarpinę pakeisti
Prateka vanduo per tvirtinimo kotą	- Prijungimo žarnos nepilnai įsuktos į korpusą - Pajungimo žarnos tarpinė pažeista	- Prijungimo žarnas prisukti ranka - tarpinę pakeisti
Per maža karšto vandens temperatūra	- Neteisingai nustatytas karšto vandens ribotuvas	- Nustatyti karšto vandens ribotuvą



**Sigurnosne upute**

- △ Prilikom montaže se radi sprječavanja prignječenja i posjekotina moraju nositi rukavice.
- △ Velika razlika u pritisku između vruće i hladne vode mora biti izbalansirana.

**Upute za montažu**

- Prije montaže mora se provjeriti je li proizvod oštećen prilikom transporta. Nakon ugradnje se ne priznaju nikakve reklamacije koje se odnose na površinska i transportna oštećenja.
- Cijevi i armatura moraju biti postavljeni, isprani i testirani prema važećim normama.
- Obvezno se moraju uvažiti propisi o instalacijama koji vrijede u dotičnoj zemlji.

**Tehnički podaci**

Najveći dopušteni tlak:	tlak 1 MPa
Preporučeni tlak:	0,1 - 0,5 MPa
Probni tlak:	1,6 MPa (1 MPa = 10 bar = 147 PSI)
Temperatura vruće vode:	tlak 60°C
Termička dezinfekcija:	70°C / 4 min
Proizvod je koncipiran isključivo za pitku vodu!	

**Opis simbola**

Nemojte koristiti silikon koji sadrži octenu kiselinu!



**Regulacija** (pogledaj stranicu 39)

Namještanje limitera tople vode. U kombinaciji s protočnim bojlerima nije preporučljiva primjena sustava za blokiranje dotoka tople vode.



**Mjere** (pogledaj stranicu 40)

**Dijagram protoka**

(pogledaj stranicu 40)

**Rezervni dijelovi**

(pogledaj stranicu 42)

XXX = Boje
000 = Krom
130 = Polished Bronze
140 = Brushed Bronze
330 = Polished Black Chrome
340 = Brushed Black Chrome
670 = Matt Black
800 = Plemeniti Čelik
950 = Brushed Brass

**Posebni pribor** (Nije sadržano u isporuci!)

Prilagodnik (G<sup>3/8</sup> / G<sup>1/2</sup>)  
#93395000 (pogledaj stranicu 42)



**Čišćenje** (pogledaj stranicu 35)



**Upotreba** (pogledaj stranicu 35)

Hansgrohe preporuča da ujutro ili nakon duljeg nekoristenja prvih 1/2 litre vode ne upotrebljavate za piće.

**Oznaka testiranja**

(pogledaj stranicu 44)

Greška	Uzrok	Otklanjanje
Nedovoljno vode	- Aerator je začepljen naslagama kamena ili prljav	- Očistite ili zamijenite aerator.
Ručica se zaglavila	- Neispravan uložak Taloženje kamena	- Zamijenite uložak
Slavina kaplje	- Neispravan uložak	- Zamijenite uložak
Voda izlazi u području rotirajućih dijelova slavine	- O-prsten je neispravan	- Zamijenite O-prsten
Voda izlazi na dijelu gdje je slavina učvršćena	- Priključna crijeva nisu potpuno učvršćena na tijelo - O-prsteni priključnih crijeva su neispravni	- Priključna crijeva učvrstite rukom - Zamijenite O-prsten
Preiska temperatura tople vode	- Limiter vruće vode nije dobro podešen	- Podesite limiter vruće vode





## Instrucțiuni de siguranță

- ⚠ La montare utilizați mănuși pentru evitarea contuziunilor și tăierii mâinilor.
- ⚠ Diferențele de presiune mari între alimentarea cu apă rece și apă caldă trebuie echilibrate.

## Instrucțiuni de montare

- Înainte de instalare verificați, dacă produsul prezintă deteriorări de transport. După instalare garanția nu acoperă deteriorările de transport și cele de suprafață.
- Conductele și bateriile trebuie montate, spălate și verificate conform normelor în vigoare.
- Respectați reglementările referitoare la instalare valabile în țara respectivă.

## Date tehnice

Presiune de funcționare:	max. 1 MPa
Presiune de funcționare recomandată:	0,1 - 0,5 MPa
Presiune de verificare:	1,6 MPa (1 MPa = 10 bar = 147 PSI)
Temperatura apei calde:	max. 60°C
Dezinfecție termică:	70°C / 4 min
Produsul este destinat exclusiv pentru apă potabilă.	

## Descrierea simbolurilor



Nu utilizați silicon cu conținut de acid acetic!



**Reglare** (vezi pag. 39)

Reglarea limitatorului de apă caldă. Nu se recomandă folosirea unui limitator de apă caldă în combinație cu un boiler instant.



**Dimensiuni** (vezi pag. 40)



**Diagrama de debit** (vezi pag. 40)



**Piese de schimb** (vezi pag. 42)

XXX = Coduri de culori  
 000 = Crom  
 130 = Polished Bronze  
 140 = Brushed Bronze  
 330 = Polished Black Chrome  
 340 = Brushed Black Chrome  
 670 = Matt Black  
 800 = Oțel Inox  
 950 = Brushed Brass

## Accesorii opționale

(nu este inclus în setul livrat)



Adaptor (G<sup>3</sup>/<sub>8</sub> / G<sup>1</sup>/<sub>2</sub>)  
 #93395000 (vezi pag. 42)



**Curățare** (vezi pag. 35)



**Utilizare** (vezi pag. 35)

Hansgrohe vă recomandă, ca dimineața sau după perioade mai lungi de pauză să nu folosiți prima jumătate de litru de apă pentru băut.



**Certificat de testare** (vezi pag. 44)

Deranșament	Cauza	Măsuri de remediere
Prea puțină apă	- Depuneri de calcar și impurități pe pulverizatorul de aer.	- Curățați / schimbați pulverizatorul de aer.
Bateria se mișcă dificil	- Cartuș defect din cauza depunerilor de calcar	- Schimbați cartușul.
Bateria picură	- Cartuș defect	- Schimbați cartușul.
Scurgere de apă în zona pipei rabatabile.	- Inel O defect	- Schimbați inelul O.
Scurgere de apă la șaftul de fixare.	- Furtunurile de racordare nu sunt bine înșurubate în corpul bateriei. - Inelul O de la furtunul de racord defect	- Strângeți cu mâna furtunurile de racordare. - Schimbați inelul O.
Temperatura apei calde este prea mică	- Limitarea temperaturii apei calde setată incorect.	- Setați limitarea temperaturii apei calde.

**Montare** (vezi pag. 36)





## Υποδειξεις ασφαλείας

- ⚠ Για να αποφύγετε τραυματισμούς κατά τη συναρμολόγηση πρέπει να φοράτε γάντια.
- ⚠ Οι διαφορές της πίεσης μεταξύ της σύνδεσης κρύου και ζεστού νερού θα πρέπει να αντισταθμίζονται.

## Οδηγίες συναρμολόγησης

- Πριν τη συναρμολόγηση πρέπει να εξεταστεί το προϊόν για ζημιές μεταφοράς. Μετά την εγκατάσταση δεν αναγνωρίζονται ζημιές από τη μεταφορά ή επιφανειακές ζημιές.
- Οι σωλήνες και η μπαταρία πρέπει να τοποθετηθούν σύμφωνα με τα ισχύοντα πρότυπα, να τεθούν υπό πίεση και να δοκιμαστούν.
- Θα πρέπει να τηρούνται οι οδηγίες εγκατάστασης που ισχύουν σε κάθε κράτος.

## Τεχνικά Χαρακτηριστικά

Λειτουργία πίεσης:	έως 1 MPa
Συνιστώμενη λειτουργία πίεσης:	0,1 - 0,5 MPa
Πίεση ελέγχου:	1,6 MPa (1 MPa = 10 bar = 147 PSI)
Θερμοκρασία ζεστού νερού:	έως 60°C
Θερμική απολύμανση:	70°C / 4 min

Το προϊόν έχει σχεδιαστεί αποκλειστικά για πόσιμο νερό!

## Περιγραφή συμβόλων



Μην χρησιμοποιείτε σιλικόνη που περιέχει οξικό οξύ!



**Ρύθμιση** (βλ. Σελίδα 39)

Ρύθμιση του δοσομετρητή ζεστού νερού. Δεν συνιστάται η διάταξη φραγής ζεστού νερού σε συνδυασμό με ταχυθερμοσίφωνα.

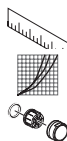

**Διαστάσεις** (βλ. Σελίδα 40)

**Διάγραμμα ροής** (βλ. Σελίδα 40)

**Ανταλλακτικά** (βλ. Σελίδα 42)

XXX	= Χρώματα
000	= Επιχρωμασμένο
130	= Polished Bronze
140	= Brushed Bronze
330	= Polished Black Chrome
340	= Brushed Black Chrome
670	= Matt Black
800	= Οπτική Ανοξειδωτου Χάλυβα
950	= Brushed Brass

**Ειδικά αξεσουάρ** (δεν περιλαμβάνεται στον παραδοτέο εξοπλισμό)



Προσαρμογέας (G<sup>3</sup>/<sub>8</sub> / G<sup>1</sup>/<sub>2</sub>)  
#93395000 (βλ. Σελίδα 42)



**Καθαρισμός** (βλ. Σελίδα 35)



**Χειρισμός** (βλ. Σελίδα 35)

Η Hansgrohe συνιστά το πρωί ή μετά από μεγάλα χρονικά διαστήματα αχρησίας να μην χρησιμοποιείτε το πρώτο μισό λίτρο νερό σαν πόσιμο.



**Σήμα ελέγχου** (βλ. Σελίδα 44)

Βλάβη	Αιτία	Διόρθωση
Ανεπαρκές νερό	- Άλατα και βρωμιά στο φίλτρο	- Καθαρίστε/αλλάξτε το φίλτρο
Σκληρή μπαταρία (μεικτή)	- Ελαττωματικό φυσίγγιο, άλατα	- Αλλαγή φυσιγγίου
Η μπαταρία σιάζει	- Ελαττωματικό φυσίγγιο	- Αλλαγή φυσιγγίου
Διαρροή νερού στην περιοχή του περιστρεφόμενου ρουζουινού.	- Ελαττωματικός στρογγυλός δακτύλιος	- Αλλάξτε το στρογγυλό δακτύλιο
Διαρροή νερού στον άξονα στερέωσης	- Οι σωλήνες σύνδεσης δεν είναι πλήρως βιδωμένοι στο βασικό κορμό - Ο στρογγυλός δακτύλιος στο σωλήνα σύνδεσης είναι ελαττωματικός	- Σφίξτε τους σωλήνες σύνδεσης με το χέρι - Αλλάξτε το στρογγυλό δακτύλιο
Χαμηλή θερμοκρασία ζεστού νερού	- Λάθος ρύθμιση της περιοριστικής διάταξης ζεστού νερού	- Ρυθμίστε την περιοριστική διάταξη του ζεστού νερού



**Varnostna opozorila**

- ⚠ Pri montaži je treba nositi rokavice, da se preprečijo poškodbe zaradi zmečkanja ali urezov.
- ⚠ Velike razlike v tlaku med priključkom za mrzlo in priključkom za toplo vodo je potrebno izravnati.

**Navodila za montažo**

- Pred montažo je treba izdelek preveriti glede morebitnih transportnih poškodb. Po vgradnji transportne ali površinske poškodbe ne bodo več priznane.
- Cevi in armaturo je treba montirati, izprati in preveriti po veljavnih standardih.
- Upoštevati je treba pravilnike o inštalacijah, ki veljajo v posamezni državi.

**Tehnični podatki**

Delovni tlak:	maks. 1 MPa
Priporočeni delovni tlak:	0,1 - 0,5 MPa
Preskusni tlak:	1,6 MPa (1 MPa = 10 bar = 147 PSI)
Temperatura tople vode:	maks. 60 °C
Termična dezinfekcija:	70 °C / 4 min
Proizvod je zasnovan izključno za sanitarno vodo!	

**Opis simbola**

Ne smete uporabiti silikona, ki vsebuje ocatno kislino!

**Justiranje** (glejte stran 39)

Nastavitev omejevalnika tople vode. V povezavi s pretočnimi grelniki uporaba zapore tople vode ni priporočljiva.

**Mere** (glejte stran 40)**Diagram pretoka** (glejte stran 40)**Rezervni deli** (glejte stran 42)

XXX = Barve
000 = Krom
130 = Polished Bronze
140 = Brushed Bronze
330 = Polished Black Chrome
340 = Brushed Black Chrome
670 = Matt Black
800 = Videz Legiranega Jekla
950 = Brushed Brass

**Poseben pribor** (Ni vključeno)

Adapter (G<sup>3/8</sup> / G<sup>1/2</sup>)  
#93395000 (glejte stran 42)

**Čiščenje** (glejte stran 35)**Upravljanje** (glejte stran 35)

Hansgrohe priporoča, da zjutraj ali po daljšem času stagnacije prvega pol litra vode ne uporabite kot pitno vodo.

**Preskusni znak** (glejte stran 44)

Napaka	Vzrok	Pomoč
Malo vode	- Perlator poapnen; umazan	- Očistite/zamenjajte perlator
Težko premikanje armature	- Pokvarjen vložek, poapneno	- Zamenjajte vložek
Iz armature kaplja	- Pokvarjen vložek	- Zamenjajte vložek
Uhajanje vode ob vrtljivem izlivu	- Obročna tesnilo je pokvarjeno	- Zamenjajte obročno tesnilo
Uhajanje vode ob pritrdilnem nastavku	- Priključne cevi niso popolnoma privijačene v osnovno ogrodje - Obročna tesnila priključnih gibkih cevi so pokvarjena	- Ročno zatisnite priključne cevi - Zamenjajte obročno tesnilo
Prenizka temperatura tople vode	- Omejevalnik tople vode ni pravilno nastavljen	- Nastavite omejevalnik tople vode



## Ohutusjuhised

- △ Kandke paigaldamisel muljumis- ja löikevigastuste vältimiseks kindaid.
- △ Kui külma ja kuuma vee ühenduste surve on väga erinev, tuleb need tasakaalustada.

## Paigaldamisjuhised

- Enne paigaldamist tuleb toodet kontrollida transpordikahjustuste osas. Pärast paigaldamist ei tunnustata enam transpordi- või pinnakahjustuste kaebuseid.
- Voolikute ja segisti paigaldamisel, loputamisel ja kontrollimisel tuleb lähtuda kehtivatest normatiividest.
- Vastavas riigis kehtivaid paigalduseeskirju tuleb järgida.

## Tehnilised andmed

Töörõhk	maks. 1 MPa
Soovitatav töörõhk:	0,1 - 0,5 MPa
Kontrollsurve:	1,6 MPa
	(1 MPa = 10 baari = 147 PSI)
Kuuma vee temperatuur:	maks. 60 °C
Termiline desinfektsioon:	70 °C / 4 min

Toode on ette nähtud eranditult joogivee jaoks!

## Sümbolite kirjeldus



Ärge kasutage äädikhapet sisaldavat silikooni!



**Reguleerimine** (vt lk 39)

Sooja vee piirangu seadistamine. Ühenduses boileritega ei ole sooja vee blokeeringu soovitatav.



**Mõõtude** (vt lk 40)



**Läbivooludiagramm** (vt lk 40)



**Varuosad** (vt lk 42)

XXX =	Värvid
000 =	Kroom
130 =	Polished Bronze
140 =	Brushed Bronze
330 =	Polished Black Chrome
340 =	Brushed Black Chrome
670 =	Matt Black
800 =	Roostevaba Optik
950 =	Brushed Brass

## Spetsiaalne lisavarustus

(ei sisaldu komplektis)



Adapter (G<sup>3</sup>/<sub>8</sub> / G<sup>1</sup>/<sub>2</sub>)  
#93395000 (vt lk 42)



**Puhastamine** (vt lk 35)



**Kasutamine** (vt lk 35)

Hansgrohe soovib mitte kasutada esimest poolt liitrit hommikuti või pärast pikemat seisakuaega joogiveena.



**Kontrollsertifikaat** (vt lk 44)

Rike	Põhjus	Lahendus
Vähe vett	- Sõel on lupjunud, must	- Puhastage segisti sõel vajadusel vahetage
Segisti käib raskelt	- Tööelement on katkine, lubjastunud	- Vahetage tööelement
Segisti tilgub	- Tööelement on katkine	- Vahetage tööelement
Veeleke pööratavas jooksutorus	- O-rõngastihend on katki	- Vahetage O-rõngastihend
Veeleke kinnituse juures	- Ühendusvoolikud ei ole korralikult põhikorpuse külge kruvitud	- Kruvige ühendusvoolikud käega kinni
	- Ühendusvoolikute O-rõngastihendid katki	- Vahetage O-rõngastihend
Sooja vee temperatuur liiga madal	- Kuuma vee piirang valesti seatud	- Seadke kuuma vee piirang



## Drošības norādes

- ⚠ Montāžas laikā, lai izvairītos no saspiedumiem un iegriezumiem, nepieciešams nēsāt cimdus.
- ⚠ Jāizlīdzina spiediena atšķirības starp aukstā un karstā ūdens pievadiem.

## Norādījumi montāžai

- Pirms montāžas nepieciešams pārbaudīt, vai produktam transportēšanas laikā nav radušies bojājumi. Pēc iebūvēšanas bojājumi, kas radušies transportēšanas laikā, vai virsmas bojājumi netiek atzīti.
- Caurulvadi un armatūra ir jāuzstāda, jāizskalo un jāpārbauda saskaņā ar spēkā esošajiem standartiem.
- Jāievēro attiecīgās valsts spēkā esošās montāžas prasības.

## Tehniskie dati

Darba spiediens: maks. 1 MPa  
 Ieteicamais darba spiediens: 0,1 - 0,5 MPa  
 Pārbaudes spiediens: 1,6 MPa  
 (1 MPa = 10 bar = 147 PSI)

Karstā ūdens temperatūra: maks. 60°C  
 Termiskā dezinfekcija: 70°C / 4 min

Izstrādājums ir paredzēts tikai dzeramajam ūdenim!

## Simbolu nozīme

 Neizmantot silikonu, kas satur etiķskābi!

 **Ieregulēšana** (skat. lpp. 39)

Karstā ūdens ierobežotāja regulēšana. Kopā ar caurteces sildītājiem nav ieteicams izmantot ūdens bloķētāju.

 **Izmērus** (skat. lpp. 40)



## Caurplūdes diagramma

(skat. lpp. 40)



## Rezerves daļas (skat. lpp. 42)

XXX = Krāsu kodi  
 000 = Hroma  
 130 = Polished Bronze  
 140 = Brushed Bronze  
 330 = Polished Black Chrome  
 340 = Brushed Black Chrome  
 670 = Matt Black  
 800 = Tērauda  
 950 = Brushed Brass

## Speciāli aksesuāri

(komplektā netiek piegādāts)



Adapteris (G<sup>3/8</sup> / G<sup>1/2</sup>)  
 #93395000 (skat. lpp. 42)



**Tīrīšana** (skat. lpp. 35)



**Lietošana** (skat. lpp. 35)

Hansgrohe iesaka no rīta vai pēc ilgākiem pārtraukumiem nelietot pirmo puslitru ūdens dzeršanai.



**Pārbaudes zīme** (skat. lpp. 44)

Traucējums	Iemesls	Bojājumu novēršana
Maz ūdens	- Aerators aizkaļķojies, aizsērējis	- Tīrīt / nomainīt aeratoru
Jaucējkrāns smagi grozāms	- Bojāta kartuša, aizkaļķojusies	- Nomainīt kartušu
Jaucējkrāns pil	- Bojāta kartuša	- Nomainīt kartušu
Ūdens noplūde grozāmās iztekas rajonā	- Bojāts O-gredzens	- Nomainīt O-gredzenu
Ūdens noplūde pie nostiprinājuma	- Pieslēguma šļūtenes nav līdz galam ieskrūvētas pamatelementā	- Pieslēguma šļūtenes ar roku pievilkt stingrāk
	- Bojāti pieslēguma šļūteņu O-gredzeni	- Nomainīt O-gredzenu
Pārāk zema ūdens temperatūra	- Nepareizi noregulāta karstā ūdens	- Noregulēt karstā ūdens ierobežošanu bloķēšana





## Sigurnosne napomene

- ⚠ Prilikom montaže se radi sprečavanja prignječenja i posekotina moraju nositi rukavice.
- ⚠ Velika razlika u pritisku između vruće i hladne vode mora biti izbalansirana.

## Instrukcije za montažu

- Pre montaže se mora proveriti da li je proizvod oštećen pri transportu. Nakon ugradnje se ne priznaju nikakve reklamacije koje se odnose na površinska i transportna oštećenja.
- Vodovi i armatura moraju biti postavljeni, isprani i testirani prema važećim normama.
- Treba se pridržavati propisa koji u određenim zemljama važe za instalacije.

## Tehnički podaci

Radni pritisak:	maks. 1 MPa
Preporučeni radni pritisak:	0,1 - 0,5 MPa
Probni pritisak:	1,6 MPa (1 MPa = 10 bar = 147 PSI)
Temperatura vruće vode:	maks. 60°C
Termička dezinfekcija:	70°C / 4 min
Proizvod je koncipiran isključivo za pijaću vodu!	

## Opis simbola



Nemojte koristiti silikon koji sadrži sircetnu kiselinu!



## Podešavanje (vidi stranu 39)

Podešavanje ograničivača tople vode. U kombinaciji sa protočnim bojlerima ne preporučuje se primena sistema za blokiranje dotoka tople vode.



## Mere (vidi stranu 40)



## Dijagram protoka (vidi stranu 40)



## Rezervni delovi (vidi stranu 42)

XXX	= Oznake boja
000	= Hrom
130	= Polished Bronze
140	= Brushed Bronze
330	= Polished Black Chrome
340	= Brushed Black Chrome
670	= Matt Black
800	= Dezen Plemeniti Čelik
950	= Brushed Brass

## Poseban pribor (Nije sadržano u isporuci)



Adapter (G<sup>3/8</sup> / G<sup>1/2</sup>)  
#93395000 (vidi stranu 42)



## Čišćenje (vidi stranu 35)



## Rukovanje (vidi stranu 35)

Hansgrohe preporučuje da ujutru ili nakon dužeg nekorišćenja prvih pola litre vode ne koristite za piće.



## Ispitni znak (vidi stranu 44)

Smetnja	Uzrok	Pomoć
Nedovoljno vode	- Aerator je začepljen naslagama kamena ili prljav	- Očistite ili zamenite aerator
Ručica se zaglavila	- Neispravna kartuša, nataloženi kamenac	- Zamenite kartušu
Slavina kaplje	- Neispravna kartuša	- Zamenite kartušu
Voda izlazi u zglobu slavine	- O prsten je neispravan	- Zamenite O prsten
Voda izlazi na delu gde je slavina učvršćena	- Priključna creva nisu potpuno učvršćena na telo - O prstenovi priključnih creva su neispravni	- Priključna creva učvrstite rukom - Zamenite O prsten
Preiska temperatura tople vode	- Ograničavač vruće vode nije dobro podešen	- Podesite ograničavač vruće vode





## Sikkerhetshenvisninger

- △ Bruk hansker under montasjen for å unngå klem- og kuttskader.
- △ Store trykkdifferanser mellom kaldt- og varmtvannstilkoblinger skal utlignes.

## Montagehenvisninger

- Før montasjen skal produktet sjekkes for transportskader. Etter monteringen aksepteres ikke noen transport- eller overflateskader.
- Ledningene og armaturen skal monteres, spyles og sjekkes iht. de gyldige normer.
- Gjeldende retningslinjer for rørleggerarbeid i de enkelte land skal følges.

## Tekniske data

Driftstrykk	maks. 1 MPa
Anbefalt driftstrykk:	0,1 - 0,5 MPa
Prøvetrykk	1,6 MPa (1 MPa = 10 bar = 147 PSI)
Varmtvannstemperatur	maks. 60°C
Termisk desinfisering:	70°C / 4 min
Produktet er utelukkende designet for drikkevann!	

## Symbolbeskrivelse



Ikke bruk silikon som inneholder eddiksyre!



## Justering (se side 39)

Innstilling av varmtvannsbegrensning. I forbindelse med gjennomstrømningsvarmere er det ikke anbefalt å bruke en varmtvannsperre.



## Mål (se side 40)



## Gjennomstrømningsdiagram (se side 40)



## Serviceledere (se side 42)

XXX =	Fargekode
000 =	Krom
130 =	Polished Bronze
140 =	Brushed Bronze
330 =	Polished Black Chrome
340 =	Brushed Black Chrome
670 =	Matt Black
800 =	Rusfritt Stål Optikk
950 =	Brushed Brass

## Ekstratilbehør (ikke med i leveransen)



Adapter (G<sup>3/8</sup> / G<sup>1/2</sup>)  
#93395000 (se side 42)



## Rengjøring (se side 35)



## Betjening (se side 35)

Om morgen og etter lengre stagnasjonstider anbefaler Hansgrohe å ikke bruke den første halvliteren som drikkevann.



## Prøvemerket (se side 44)

Feil	Årsak	Feilrettelse
Lite vann	- Luftsprudler forkalket, skitten	- Luftsprudler rengjøres / byttes
Armatyr ikke lett bevegelig	- Kartusj defekt, forkalkning	- Kartusj byttes
Armatyr drypper	- Kartusj defekt	- Kartusj byttes
Vannlekkasje i området for svingutløpet	- O-ring defekt	- O-ring byttes
Vannlekkasje på festeskaf	- Tilkoblingslanger ikke skrudd helt inn i basiselement	- Tilkoblingslanger trekkes fast fra hånd
	- O-ring på tilkoblingslanger defekt	- O-ring byttes
For lav varmtvannstemperatur	- Varmtvannsbegrensning er feil innstilt	- Varmtvannsbegrensning innstilles





## Указания за безопасност

- ⚠ При монтажа трябва да се носят ръкавици, за да се избегнат наранявания поради притискане или порязване.
- ⚠ Големите разлики в налягането между изводите за студената и топлата вода трябва да се изравняват.

## Указания за монтаж

- Преди монтажа продуктът трябва да се провери за транспортни щети. След монтажа не се признават транспортни или повърхностни щети.
- Тръбопроводите и арматурата трябва да се монтират, промият и проверят в съответствие с валидните норми.
- Трябва да бъдат спазвани валидните в съответните страни предписания за инсталиране.

## Технически данни

Работно налягане:	макс. 1 МПа
Препоръчително работно налягане:	0,1 - 0,5 МПа
Контролно налягане:	1,6 МПа
	(1 МПа = 10 bar = 147 PSI)
Температура на горещата вода:	макс. 60 °C
Термична дезинфекция:	70 °C / 4 мин
Продуктът е разработен само за питейна вода!	

## Описание на символите



Не използвайте силикон, съдържащ оцетна киселина!



**Юстиране** (вижте стр. 39)

Настройка на ограничителя за топлата вода. Във връзка с проточни нагреватели не се препоръчва блокировка за топлата вода



**Размери** (вижте стр. 40)



**Диаграма на потока**  
(вижте стр. 40)



**Сервизни части** (вижте стр. 42)

XXX	= Цветово кодиране
000	= Хром
130	= Polished Bronze
140	= Brushed Bronze
330	= Polished Black Chrome
340	= Brushed Black Chrome
670	= Matt Black
800	= Оптика На Благородна Стомана
950	= Brushed Brass

## Специални принадлежности

(не се съдържа в обема на доставка)



Адаптер (G<sup>3</sup>/<sub>8</sub> / G<sup>1</sup>/<sub>2</sub>)  
#93395000 (вижте стр. 42)



**Почистване** (вижте стр. 35)



**Обслужване** (вижте стр. 35)

Hansgrohe препоръчва, сутрин и след по-продължително спиране първият половин литър да не се използва като питейна вода.



**Контролен знак** (вижте стр. 44)

Неизправност	Причина	Помощ
Малко вода	- Аераторът е покрит с варовик, замърсен	- Почистете / сменете аератора
Трудно подвижна арматура	- Дефектна гилза, покрита с варовик	- Сменете гилзата
Арматурата капе	- Дефектна гилза	- Сменете гилзата
Избиване на вода в областта на завъртания се изходящ накрайник	- Дефектен О-образен пръстен	- Смяна на О-образен пръстен
Избиване на вода от закрепващата шийка	- Свързващите маркучи не са напълно завинтени в основното тяло - Дефектен О-образен пръстен на свързващия маркуч	- Затегнете на ръка свързващите маркучи - Смяна на О-образен пръстен
Твърде ниска температура на водата	- Ограничението за топлата вода е грушно настроено	- Настройте ограничението за топлата вода

**安全上の注意**

- △ 施工の際は手を挟んだり怪我をしないように、手袋をはめてください。
- △ 給水・湯の圧力差は0.1(MPa)以内としてください。

**施工上の注意**

- 製品の施工前に輸送でのダメージがないか確認してください。施工後のキズ等のお申し出はお断りさせて頂いています。
- 配管と水栓は、関連法規に従って施工、洗浄、および試験を行ってください。
- 施工行う地域に適用される関連法規をお守りください。

**技術資料**

使用圧力:	最大 1 MPa
推奨使用水圧:	0,1 - 0,5 MPa
耐圧試験圧力:	1,6 MPa (1 MPa = 10 bar = 147 PSI)
給湯温度:	最大 60°C
お湯による高温消毒:	70°C / 4分

この製品は飲料水での使用が前提となっています(日本においては水道法に適合する飲料水)!

**アイコンの説明**

酢酸系シリコンをご使用にならないでください!



**調整** (次のページを参照 39)

お湯の流量制限の設定方法。瞬間湯沸かし器をご利用の際はお湯の流量制限はしないでください。



**寸法** (次のページを参照 40)



**流量曲線図** (次のページを参照 40)



**スペアパーツ** (次のページを参照 42)

XXX =	仕上げ色
000 =	Chrome
130 =	Polished Bronze
140 =	Brushed Bronze
330 =	Polished Black Chrome
340 =	Brushed Black Chrome
670 =	Matt Black
800 =	Stainless Steel Optic
950 =	Brushed Brass

**スペシャルパーツ** (別手配部品)



アダプタ (G $\frac{3}{8}$  / G $\frac{1}{2}$ )  
#93395000 (次のページを参照 42)



**お手入れ方法** (次のページを参照 35)



**使用方法** (次のページを参照 35)

ハンスグローエは、朝または長い間使用されなかった後に吐水する最初の0.5リットルは飲料水として使用しないことをお勧めします。



**認証について** (次のページを参照 44)

症状	原因	対応策
流量が少ない	- エアレーターにカルキが付着/汚れている	- エアレーターを清掃/交換をしてください
水栓の開閉が重い	- カルキによるカートリッジ不具合	- カートリッジを交換してください
水栓の水漏れ	- カートリッジの不良	- カートリッジを交換してください
スパウトから水が漏れる	- Oリングの不具合	- Oリングを交換してください
固定ネジ部分から水が漏れる	- 接続ホースが本体に完全にねじ込まれていない	- 接続ホースを手で増し締めしてください
	- 接続ホースのOリングの不具合	- Oリングを交換してください
吐水温度が低すぎる	- 温度リミッターの設定が正しくない	- 温度リミッターを設定してください

**施工方法** (次のページを参照 36)



# Shqip

## Udhëzime sigurie

- △ Për të evituar lëndimet e pickimeve ose të prerjeve gjatë procesit të montimit duhet që të vishni doreza.
- △ Ndryshimet e mëdha të presionit mes lidhjeve të ujit të ftohtë dhe atij të ngrohtë duhen ekuilibruar.

## Udhëzime për montimin

- Përpara montimit duhet që produkti të kontrollohet për dëmtime nga transporti. Pas instalimit nuk do të njihet asnjë dëmtim nga transporti ose dëmtim i sipërfaqes.
- Tubacionet dhe rubinetet duhet që të montohen, të shpëlahen dhe të kontrollohen sipas standardeve në fuqi
- Duhet të respektohen linjat udhëzuese të instalimit, të vlefshme për vendet respektive.

## Të dhëna teknike

Presioni gjatë punës	maks. 1 MPa
Presioni i rekomanduar:	0,1 - 0,5 MPa
Presioni për provë:	1,6 MPa (1 MPa = 10 bar = 147 PSI)
Temperatura e ujit të ngrohtë	maks. 60°C
Dezinfektim Termik:	70°C / 4 min
Produkti është projektuar ekskluzivisht për ujë të pijshëm!	

## Përshkrimi i simbolit



Mos përdorni silikon që në përbërje ka acid acetik.



**Justimi** (shih faqen 39)

Rregullimi i kufizimit me ujë të nxehtë. Nje kombinim me një bojler ujit nuk është i rekomanduar.



**Përmasat** (shih faqen 40)



**Diagrami i qarkullimit**  
(shih faqen 40)



**Pjesët e servisit** (shih faqen 42)

XXX = Kodimi me anë të ngjyrave  
000 = Krom  
130 = Polished Bronze  
140 = Brushed Bronze  
330 = Polished Black Chrome  
340 = Brushed Black Chrome  
670 = Matt Black  
800 = Optikë Çeliku  
950 = Brushed Brass

## Pajisje të posaçme

(nuk përfshihet në vëllimin e furnizimit)



Përshatësi (G $\frac{3}{8}$  / G $\frac{1}{2}$ )  
#93395000 (shih faqen 42)



**Pastrimi** (shih faqen 35)



**Përdorimi** (shih faqen 35)

Hansgrohe rekomandon që në mëngjes ose pas periudhave të gjata që gjysmë litri i parë mos të pihet



**Shenja e kontrollit** (shih faqen 44)

Demtim	Shkaku	Ndihme
Pak ujë	- Spherndaresi i ajrit me kalk, me papasteriti	- Pastroni spherndaresin e ajrit/kembejeni
Armatura punon rende	- Kartusha me defekt, me kalk	- Kembeni kartushen
Armatura pikon	- Kartusha me defekt	- Kembeni kartushen
Derdhje e ujit në zonën e daljes	- Unaza O me defekt	- Kembeni unazen O
Dalje e ujit ne cilindrin fiksues	- Tubat e lidhjes jo komplet te vidhosur ne karkasen baze - Unaza O tek tubi lidhes me defekt	- Shtrengojini manualisht tubat e lidhur - Kembeni unazen O
Temperaturë e ulët e ujit të ngrohtë	- Kufiri i ujit te ngrohte eshte regjistruar gabim	- Regjistroni kufirin e ujit te ngrohte

أبعاد (راجع صفحة 40)

رسم للصراف (راجع صفحة 40)

قطع الغيار (راجع صفحة 42)

الألوان = XXX

كروم = 000

Polished Bronze = 130

Brushed Bronze = 140

Polished Black Chrome = 330

Brushed Black Chrome = 340

Matt Black = 670

مظهر الإستنليس ستيل = 800

Brushed Brass = 950

## ملحقات خاصة

(غير مدرج مع المحتويات المسلمة)

محول (G<sup>3/8</sup> / G<sup>1/2</sup>)

#93395000 (راجع صفحة 42)

التنظيف (راجع صفحة 35)

التشغيل (راجع صفحة 35)

تتصح شركة هانزجر وهي Hansgrohe بعدم استخدام أول نصف لتر من الماء لغرض الشرب وذلك في الصباح أو بعد توقف استخدام الماء لفترات طويلة نسبياً.

شهادة اختبار (راجع صفحة 44)

## تنبيهات الأمان

⚠ يجب إرتداء قفازات لليد أثناء التركيب لتجنب حدوث أخطار الإنحشار أو الجروح.

⚠ يجب أن يكون تيار الماء الساخن والماء البارد متعادلين في الضغط.

## تعليمات التركيب

- قبل القيام بعملية التركيب، يجب فحص المنتج للتأكد من خلوه من أية تلفيات ناتجة عن النقل. بعد القيام بعملية التركيب، لن يتم الاعتراف بوجود أية تلفيات سطحية أو تلفيات ناتجة عن عملية النقل.
- يجب تركيب وغسيل واختبار التوصيلات وخلطات المياه طبقاً للمعايير السارية.
- يجب مراعاة القواعد الخاصة بالتركيب وأعمال السباكة وفقاً للوائح الخاصة بكل بلد.

## المواصفات الفنية

ضغط التشغيل: الحد الأقصى 1 ميجاباسكال  
 ضغط التشغيل الموصى به: 0,1 - 0,5 ميجاباسكال  
 ضغط الاختبار: 1,6 ميجاباسكال  
 (1 ميجاباسكال = 10 بار = 147 PSI)  
 درجة حرارة الماء الساخن: الحد الأقصى 60°C  
 تعقيم حراري: 70°C / 4 الدقيقة  
 المنتج مخصص فقط لماء الشرب!

## وصف الرمز

هام! لا تستخدم السليكون الذي يحتوي على أحماض!

## الضبط (راجع صفحة 39)

ضبط تحديد المياه الدافئة. لا ينصح باستخدام محدد المياه الدافئة مع سخان المياه الوتقي.

العلاج والإصلاح	السبب	العطل
قم بتنظيف / تغيير خلط الهواء	- خلط الهواء متراكم عليه الجير / الانساختات	الماء غير كافٍ
قم بتغيير الخرطوشة	- الخرطوشة تالفة، تراكم عليها الجير	الخلط ثقيل الحركة
قم بتغيير الخرطوشة	- الخرطوشة تالفة	تساقط قطرات مياه من الخلط
قم بتغيير الحلقة الدائرية	- الحلقة الدائرية تالفة	خروج الماء من منطقة الخروج المتارجح
- اربط خرطوم التوصيل بيدك	خرطوم التوصيل ليست مربوطة في الجزء الرئيسي بشكل كامل	خروج الماء من جزء التثبيت
قم بتغيير الحلقة الدائرية	- الحلقة الدائرية الخاصة بخرطوم التوصيل تالفة	
قم بضبط محدد الماء الساخن	- محدد الماء الساخن مضبوط بشكل خاطيء	درجة حرارة الماء الساخن منخفضة للغاية

التركيب (راجع صفحة 36)

## Güvenlik uyarıları

- ⚠ Montaj esnasında ezilme ve kesilme gibi yaralanmaları önlemek için eldiven kullanılmalıdır.
- ⚠ Sıcak ve soğuk su bağlantıları arasında büyük basınç farklılıkları varsa, bu basınç farklılıklarının dengelenmesi gerekir.

## Montaj açıklamaları

- Montaj işleminden önce ürün nakliye hasarları yönünden kontrol edilmelidir. Montaj işleminden sonra nakliye veya yüzey hasarları için sorumluluk üstlenilmemektedir.
- Boruların ve armatürün montajı, yıkanması ve kontrolü geçerli normlara göre yapılmalıdır.
- Ülkelerde geçerli kurulum yönetmeliklerine riayet edilmelidir.

## Teknik bilgiler

İşletme basıncı:	azami 1 MPa
Tavsiye edilen işletme basıncı:	0,1 - 0,5 MPa
Kontrol basıncı:	1,6 MPa
	(1 MPa = 10 bar = 147 PSI)

Sıcak su sıcaklığı: azami 60°C  
Termik dezenfeksiyon: 70°C / 4 dak

Ürün sadece şebeke suyu için tasarlanmıştır!

## Simge açıklaması

 Asetik asit içeren silikon kullanmayın!

 **Ayarlama** (bakınız sayfa 39)

Sıcak su sınırlamasının ayarlanması. Sıcak su kilidinin sürekli ısıtıcıyla kullanılması tavsiye edilmez.

 **Ölçüleri** (bakınız sayfa 40)



**Akış diyagramı** (bakınız sayfa 40)

**Yedek Parçalar** (bakınız sayfa 42)

XXX = Renkler  
000 = Krom  
130 = Polished Bronze  
140 = Brushed Bronze  
330 = Polished Black Chrome  
340 = Brushed Black Chrome  
670 = Matt Black  
800 = Paslanmaz Çelik-Optik  
950 = Brushed Brass

## Özel aksesuarlar

(Teslimat kapsamına dahil değildir)



Adaptör (G<sup>3</sup>/<sub>8</sub> / G<sup>1</sup>/<sub>2</sub>)  
#93395000 (bakınız sayfa 42)



**Temizleme** (bakınız sayfa 35)



**Kullanımı** (bakınız sayfa 35)

Hansgrohe sabahları uzun durgunluk süresi sonrasında ilk yarım litre suyun içme suyu olarak kullanılmamasını önerir.



**Kontrol işareti** (bakınız sayfa 44)

arıza	sebebi	yardım
Az su geliyor	- Perlatör kireçlenmiş, kirlenmiş	- Perlatör kireçlenmiş, kirlenmiş
Batarya kullanımı ağırlaşıyor	- Kartuş Bozulmuş ve kireçlenmiş olabilir	- Kartuşu değiştirin
Batarya su damlatıyor	- Kartuş bozuk olabilir	- Kartuşu değiştirin
Döner çıkış bölgesinden su çıkışı	- O-ring arızalı	- O-ringi değiştirin
Sabitleme kutusundan su çıkışı	- Bağlantı hortumları ana gövdeye tamamen vidalanmamış	- Bağlantı hortumlarını elinizle sıkın
	- Bağlantı hortumundaki O-ring arızalı	- O-ringi değiştirin
Sıcak suyun derecesi çok düşük	- Isı limitleyici düzgün çalışmıyor	- Isı limitleyiciyi yeniden ayarlayın

**Garanti Belgesi****Üretici veya İthalatçı Firmanın**

Unvanı: Hansgrohe Armatür Ltd. Şti  
Adresi: Fulya Mahallesi Bahçeler Sokak Efe han 20/C  
Mecidiyeköy Şişli İstanbul  
Telefonu: (0-212) 273 07 30  
Faks: (0-212) 273 07 40  
web adresi: www.hansgrohe.com.tr

**Malın**

Markası: Hansgrohe  
Cinsi: Sıhhi tesisat malzemesi  
Garanti Süresi: 2 YIL  
Azami Tamir Süresi: 20 İş günü

**Genel Müdür**

Albert Emlek

Satıcı Firmanın:

Unvanı:

Adresi:

Telefonu:

Faks:

e-posta:

Fatura Tarih ve Sayısı:

Marka ve Modeli:

Teslim Tarihi ve Yeri:

Yetkilinin İmzası:

Firmanın Kaşesi:

Bu bölümü, ürünü aldığınız Yetkili Satıcı imzalayacak ve kaşeleyecektir.



## Biztonsági utasítások

- ⚠ A szerelésnél a zúzódások és vágási sérülések elkerülése érdekében kesztyűt kell viselni.
- ⚠ A hidegvíz- és a melegvíz-csatlakozások közötti nagy nyomáskülönbséget kikell egyenlíteni!

## Szerelési utasítások

- A szerelés előtt ellenőrizni kell, hogy a terméknek nincs-e szállítási sérülése. Beépítés után a szállítási- vagy felületi sérüléseket nem ismerik el.
- A vezetékeket és a csaptelepet az érvényes szabványoknak megfelelően kell felszerelni, öblíteni és ellenőrizni
- Az egyes országokban érvényes installációs irányelveket be kell tartani.

## Műszaki adatok

Üzemi nyomás:	max. 1 MPa
Ajánlott üzemi nyomás:	0,1 - 0,5 MPa
Nyomáspróba:	1,6 MPa (1 MPa = 10 bar = 147 PSI)
Forróvíz hőmérséklet:	max. 60 °C
Termikus fertőtlenítés:	70 °C / 4 perc

A terméket kizárólag ivóvízhez tervezték!

## Szimbólumok leírása



Ne használjon ecetsavtartalmú szilikont!



**Beállítás** (lásd a oldalon 39)

A meleg víz korlátozás beállítása. Átfolyós vízmelegítőknél meleg víz korlátozó használata nem ajánlott.



**Méretet** (lásd a oldalon 40)



**Átfolyási diagramm**  
(lásd a oldalon 40)



**Tartozékok** (lásd a oldalon 42)

XXX	= Színkódolás
000	= Króm
130	= Polished Bronze
140	= Brushed Bronze
330	= Polished Black Chrome
340	= Brushed Black Chrome
670	= Matt Black
800	= Acéloptika
950	= Brushed Brass

## Egyéb tartozék

(a szállítási egység nem tartalmazza)



Adapter (G<sup>3/8</sup> / G<sup>1/2</sup>)  
#93395000 (lásd a oldalon 42)



**Tisztítás** (lásd a oldalon 35)



**Használat** (lásd a oldalon 35)

- A csaptelepeken átfolyt víz hőmérséklete fogyasztásra szánt víz esetében a 65 °C-ot nem haladhatja meg. A csaptelep nem eredményezheti az emberi fogyasztásra (pl. ivás és főzés céljából) szánt víz minőségromlását.
- Beüzemelés és üzemszünetek után szigorúan be kell tartani a használati útmutatóban leírtakat. Beüzemeléskor a csaptelepet át kell öblíteni, legalább 2 percig történő hideg- és melegvízes folyatást javasolunk. Minimum 1 napos üzemszünet után fogyasztás előtt a csaptelepben stagnáló hideg- illetve melegvíz fogyasztása nem javasolt, a csaptelepben stagnáló vizet ki kell engedni, legalább 2 perces folyatás javasolt. A kifolyatás során nyert vizet ivóvízként, illetve ételkészítési céllal felhasználni nem szabad.
- Tekintettel arra, hogy a forró víz fémoldó képessége a hideg víznél nagyobb, emiatt főzés ivás céljából az OKI a hideg víz használatát javasolja.
- A csaptelepek perlatorát javasolt havonta vízköteleníteni, illetve fertőtleníteni. A csaptelepek tisztítása, fertőtlenítése során kizárólag olyan vegyszer alkalmazható, amely megfelel a 201/2001. (X.25) Kormányrendelet, illetve a 38/2003. (VII.7) ÉSzCsM-FVM-KvVM együttes rendeletben leírtaknak.
- A perlator működési elvéből adódóan jelentős aeroszolt képez, így Legionella expozíció szempontjából fokozott kockázatot jelent. Ezért alkalmazása nem javasolt az egészségügyi intézmények fekvőbeteg ellátó szobáiban, illetve minden olyan helyen, ahol a hideg és / vagy használati melegvíz Legionella csíraszám eléri a 49/2015 (XI.6.) EMMI rendelet alapján meghatározott beavatkozási szintet.



**Vizsgajel** (lásd a oldalon 44)



Hiba	Ok	Megoldás
Kevés víz	- A perlátor elvízkövesedett, elszennyeződött	- A perlátort megtisztítani / kicserélni.
Nehezen nyitható a csap.	- A kerámiabetét meghibásodott, elvízkövesedett.	- A kerámiabetétet ki kell cserélni.
Csöpög a csap.	- A kerámiabetét meghibásodott.	- A kerámiabetétet ki kell cserélni.
Vízkilépés a billenthető kifolyó területén	- Tömítőgyűrű meghibásodott	- Tömítőgyűrű kicserélése
Vízkilépés a rögzítőrúdon	- A csatlakozótömlők nincsenek teljesen becsavarozva az akaptestbe - Csatlakozótömlő tömítőgyűrűje meghibásodott	- A csatlakozótömlőket kézzel meghúzni - Tömítőgyűrű kicserélése
túl alacsony melegvíz hőmérséklet	- A melegvíz szabályozó rosszul van beállítva.	- A melegvíz szabályozót újra be kell állítani.



## חלקי חילוף (ראה עמוד 42)

צבעים	= XXX
מצופה כרום	= 000
Polished Bronze	= 130
Brushed Bronze	= 140
Polished Black Chrome	= 330
Brushed Black Chrome	= 340
שחור מאט	= 670
נירוסטה אופטי	= 800
Brushed Brass	= 950

## אביזרים מיוחדים (הזמנה של פריט אקסטרה)

מתאם (G $\frac{3}{8}$  / G $\frac{1}{2}$ )  
#93395000 (ראה עמוד 42)



## ניקוי (ראה עמוד 35)



## הפעלה (ראה עמוד 35)



הנס גרואה ממליצים לא להשתמש בחצי הליטר הראשון של המים הזורמים בבוקר או אחרי זמן ממושך של אי שימוש לשתייה

## תעודת בדיקה (ראה עמוד 44)



## הערות בטיחות

- יש להשתמש בכפפות בזמן ההתקנה כדי למנוע פציעות וחתכים
- למערכת המים החמים והקרים צריכים להיות לחצים שווים

## הוראות התקנה

- לפני ההתקנה, בדוק אם נגרמו למוצר נזקים בהובלה אחרי ההתקנה, לא נכיר בנזקים שנגרמו בהובלה או בנזקים במשטחים
- חובה להתקין את הצינורות והאביזרים, לשטוף אותם ולבדוק אותם על פי התקנים הישימים
- צריך לפעול על פי חוקי השרברבות הישימים במדינת ההתקנה

## נתונים טכניים

לחץ הפעלה: MPa 1  
 לחץ פעולה מומלץ: MPa 0,5 - 0,1  
 לחץ בדיקה: MPa 1,6  
 (1 MPa = 10 bar = 147 PSI)  
 טמפרטורת מים חמים: מקסימום 60°C  
 חיטוי תרמי: 70°C / 4 דקות  
 המוצר מיועד אך ורק למי שתייה!

## תיאור הסמל

אסור להשתמש בסיליקון המכיל חומצה אצטית!



## כוונן (ראה עמוד 39)



כדי להתאים את מגביל המים החמים. לא מומלץ להשתמש במגביל מים חמים ביחד עם מחמם מים בעל זרימה רצופה.

## מידות (ראה עמוד 40)



## דיאגרמת זרימה (ראה עמוד 40)



תקלה	סיבה	אופן התיקון
אין מספיק מים	- יש לנלוך או אבנית באארטור	- נקה את האארטור, והחלף בהתאם לצורך
ברז ערבוב נוקשה	- מנגנון ערבוב לא תקין, אבנית	- החלף מנגנון ערבוב
טפטוף מברז ערבוב	- מנגנון ערבוב לא תקין	- החלף מנגנון ערבוב
מים דולפים באזור הפיה המסתובבת	- אורינג לא תקין	- החלף אורינג
מים דולפים בבסיס המתוברג	- צינורות החיבור לא מוברגים עד הסוף / לגוף הבסיס	- הדק את צינורות החיבור ביד
	- האורינג בצינור החיבור אינו תקין	- החלף אורינג
טמפרטורת המים החמים נמוכה מדי	- מגביל המים החמים לא נקבע נכון	- קבע את מגביל המים החמים



## הרכבה (ראה עמוד 36)



www.hansgrohe.com/cleaning-recommendation

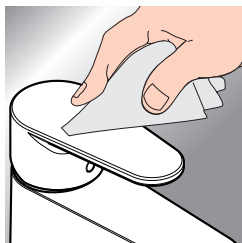

- DE** Reinigungsempfehlung / Garantie / Kontakt  
**FR** Recommendation pour le nettoyage / Garanties / Contact  
**EN** Cleaning recommendation / Warranty / Contact  
**IT** Raccomandazione di pulizia / Garanzia / Contatto  
**ES** Recomendaciones para la limpieza / Garantía / Contacto  
**NL** Aanbevelingen inzake reiniging / Garantie / Contact  
**DK** Rengøringsvejledning / Garanti / Kontakt  
**PT** Recomendações de limpeza / Garantia / Contacto  
**PL** Zalecenie dotyczący pielęgnacji / Gwarancja / Kontakt  
**CS** Doporučení k čištění / Záruka / Kontakt  
**SK** Odporúčania pre čistenie / Záruka / Kontakt  
**ZH** 清洁指南 / 担保 / 接触  
**RU** Рекомендации по очистке / Гарантия / Контакты  
**FI** Puhdistussuositus / Takuu / Kosketus

- SV** Rengöringsrekommendationer / Garanti / Contacto  
**LT** Valymo rekomendacijos / Garantija / Kontaktai  
**HR** Preporuke za čišćenje / Garancija / Kontakt  
**RO** Recomandări pentru curățare / Garanție / Contact  
**EL** Σύσταση καθαρισμού / Εγγύηση / επαφή  
**SL** Priporočila za čiščenje / Garancija / Kontakt  
**ET** Puhastussoovitused / Garantii / Kontakt  
**LV** Tīrīšanas ieteikumi / Garantija / Kontakti  
**SR** Preporuke za čišćenje / Garancija / Kontakt  
**NO** Anbefaling for rengjøring / Garanti / Kontakt  
**BG** Препоръка за почистване / Гаранция / Контакт  
**JP** お手入れの方法 / 保証について / ご連絡先  
**SQ** Këshilla rreth pastrimit / Garancia / Kontakt  
**AR** توصيات التنظيف / الضمان / اتصال  
**TR** Temizleme önerisi / Garanti / Temas  
**HU** Tisztítási tanácsok / Garancia / érintkezés  
**HE** המלצות לניקוי / אחריות / איש קשר

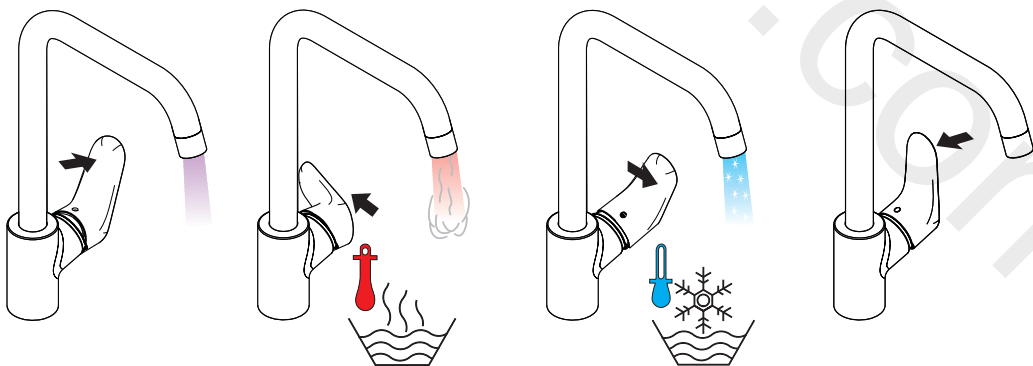

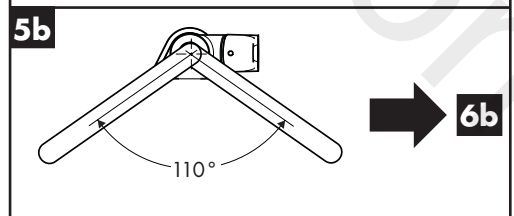
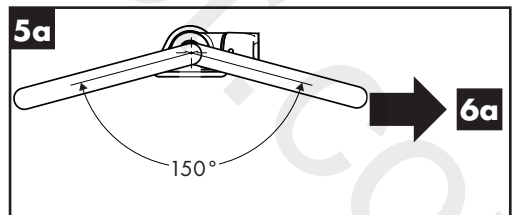
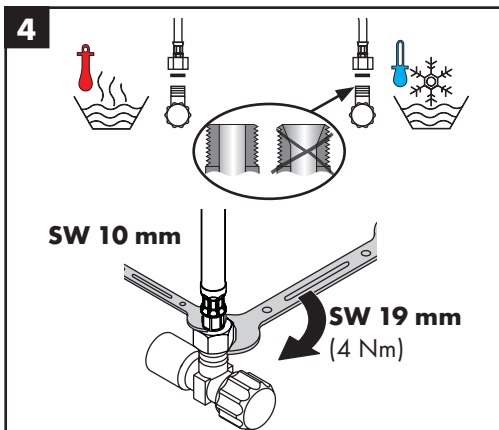
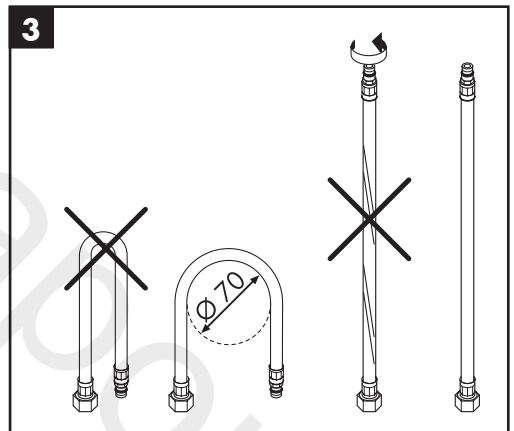
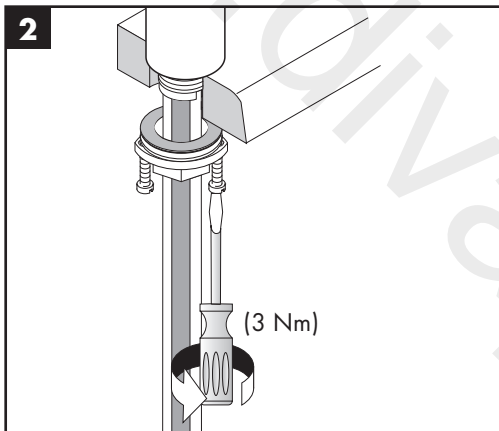
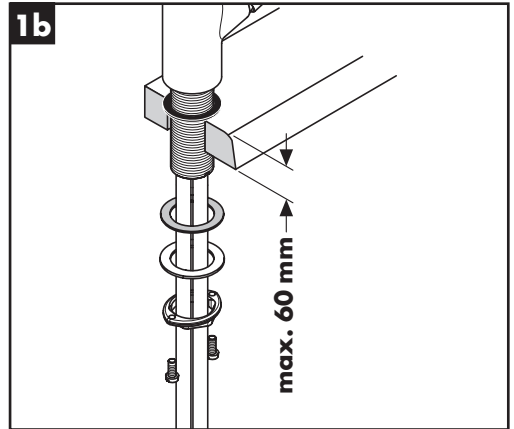
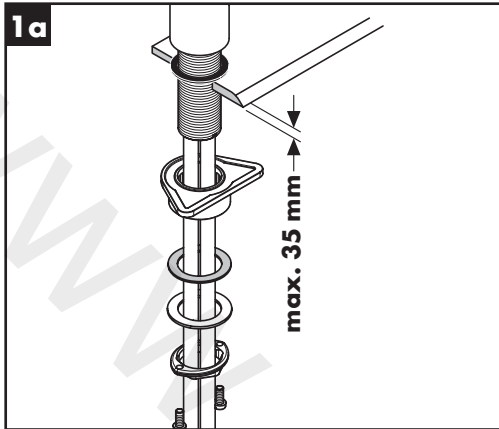



6a

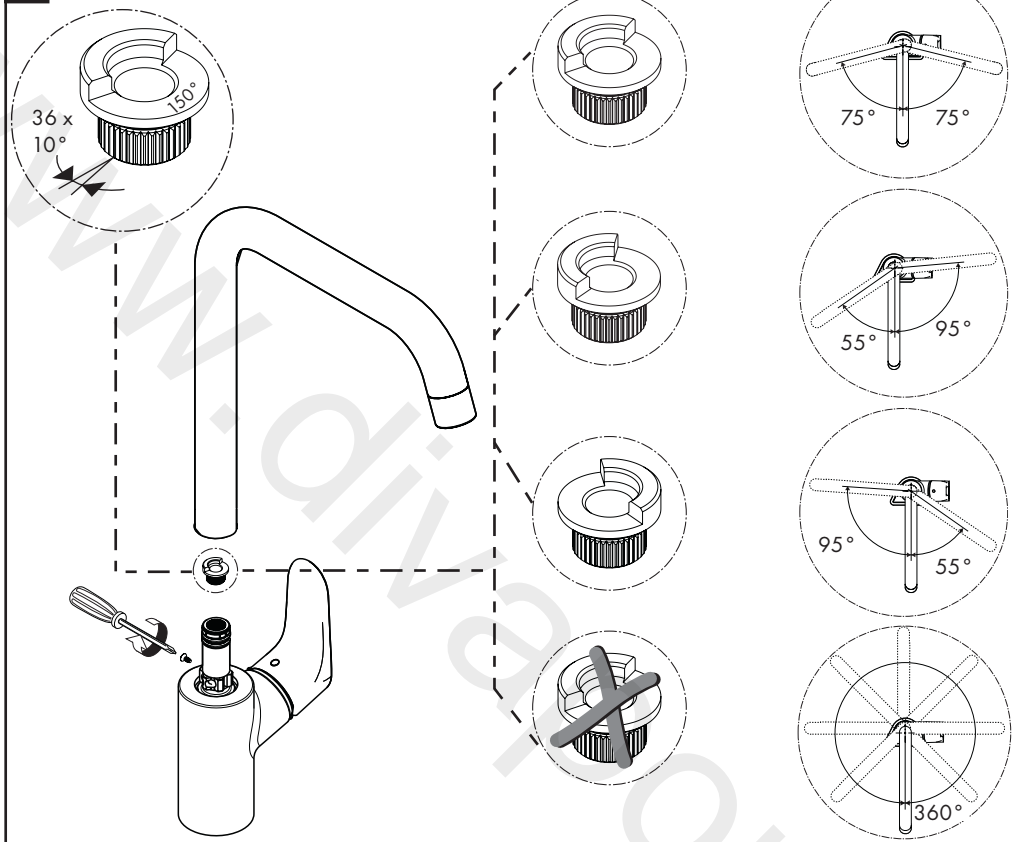



6b

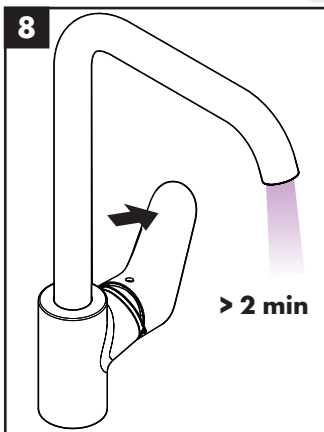
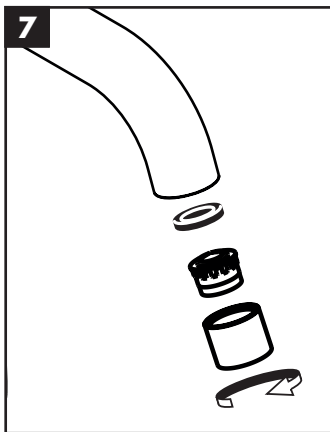
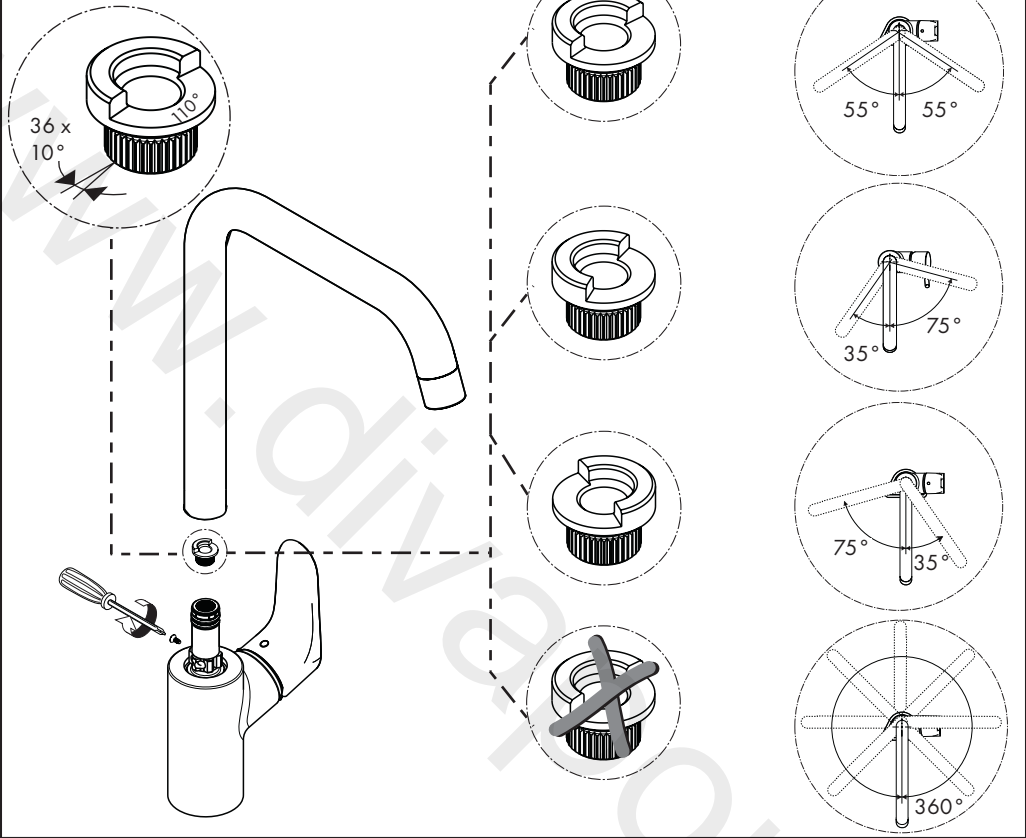

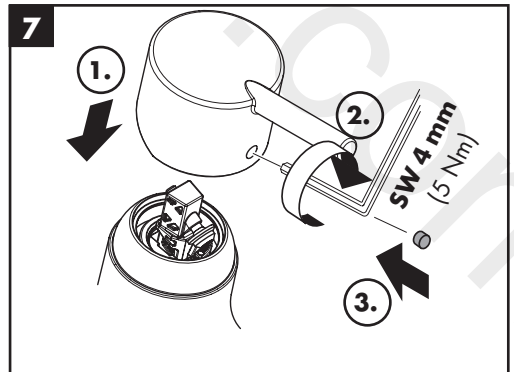
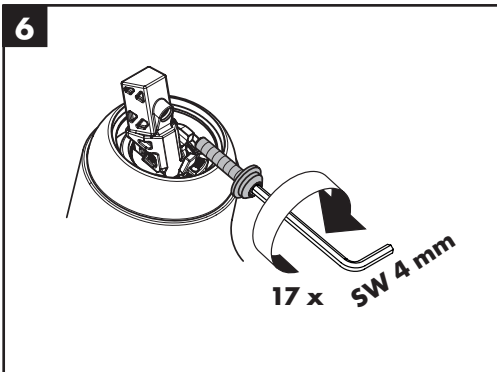
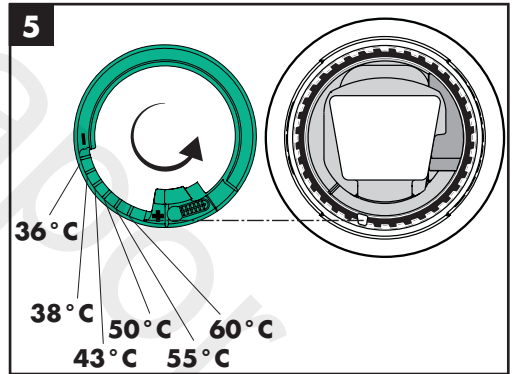
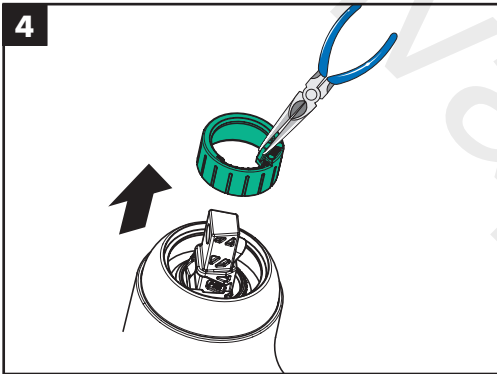
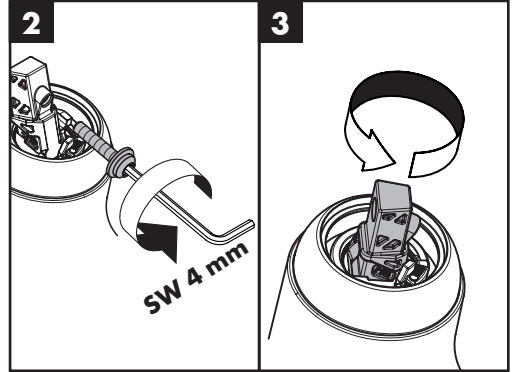
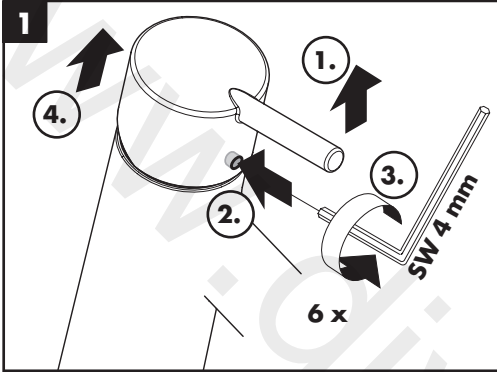



### Focus M41 280 1jet 31817XXX

### Focus M41 280 1jet 31827XXX

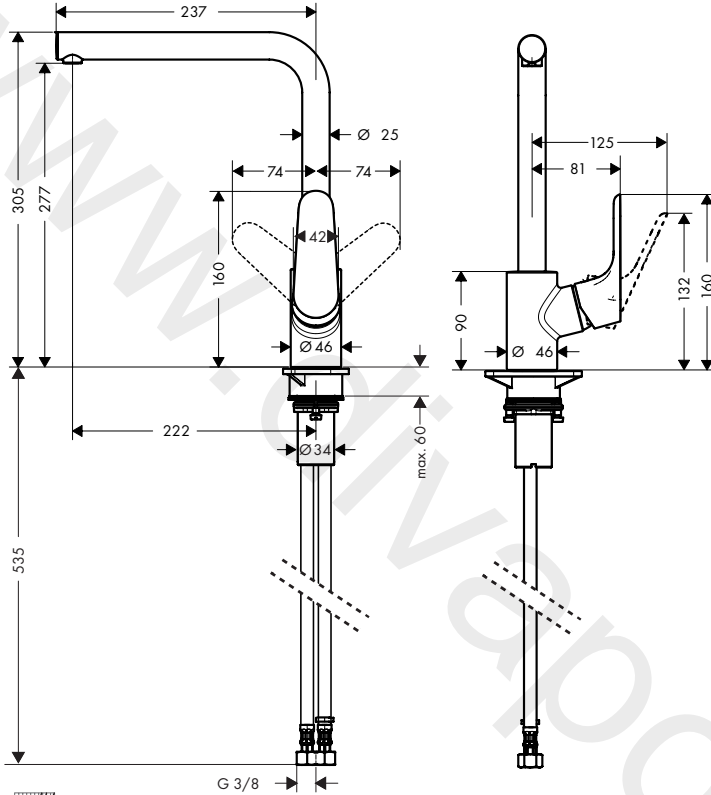

### Focus M41 280 1jet 31817XXX

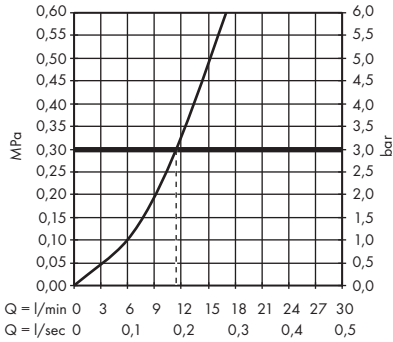

### Focus M41 280 Eco 1jet 31827XXX

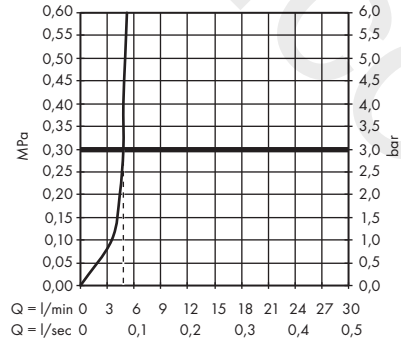



### Focus M41 260 1jet 31820XXX / 31834XXX

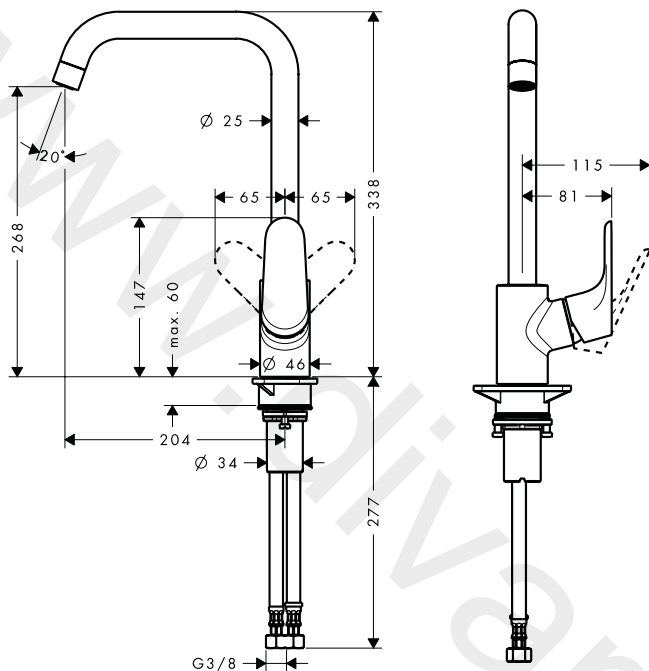

### Focus M41 260 1jet 31820XXX / 31834XXX

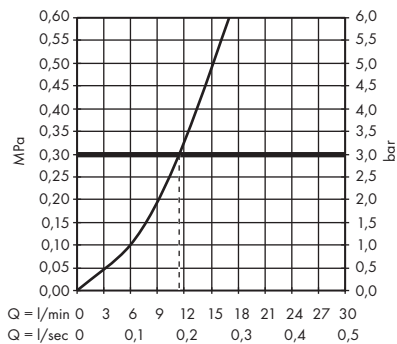



### Focus M41 280 1jet

31817XXX

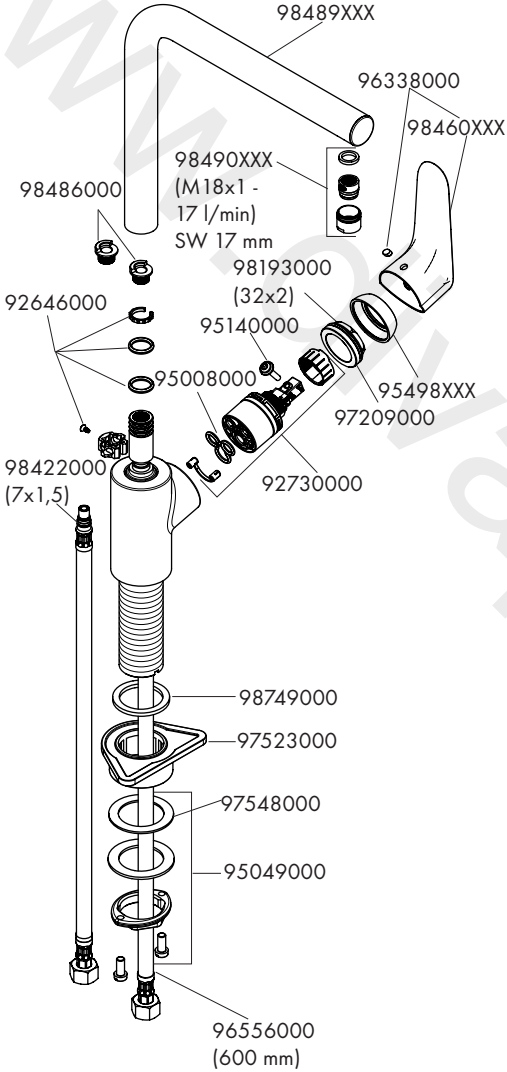

### Focus M41 280 Eco 1jet

31827XXX

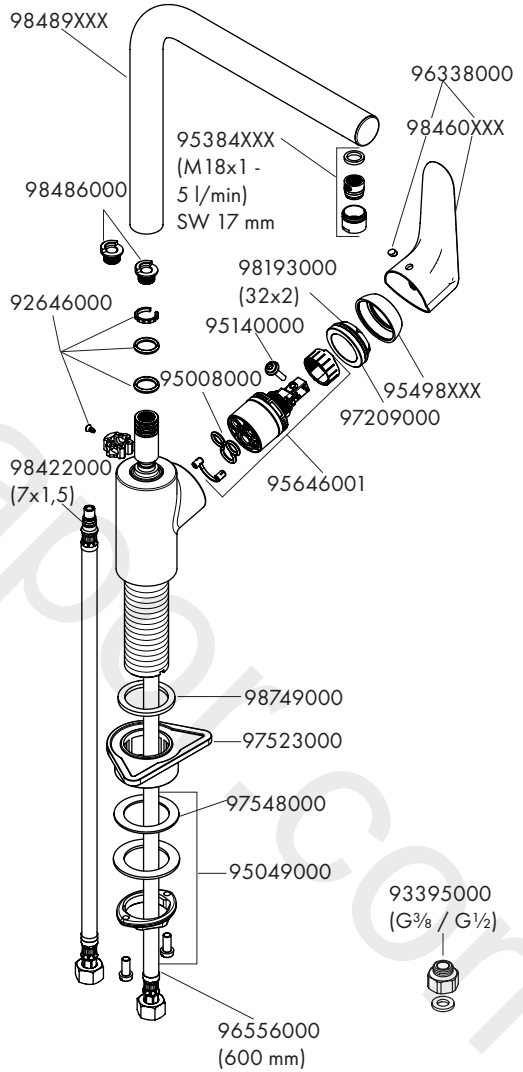

**Focus M41 260 1jet**  
31820XXX / 31834XXX

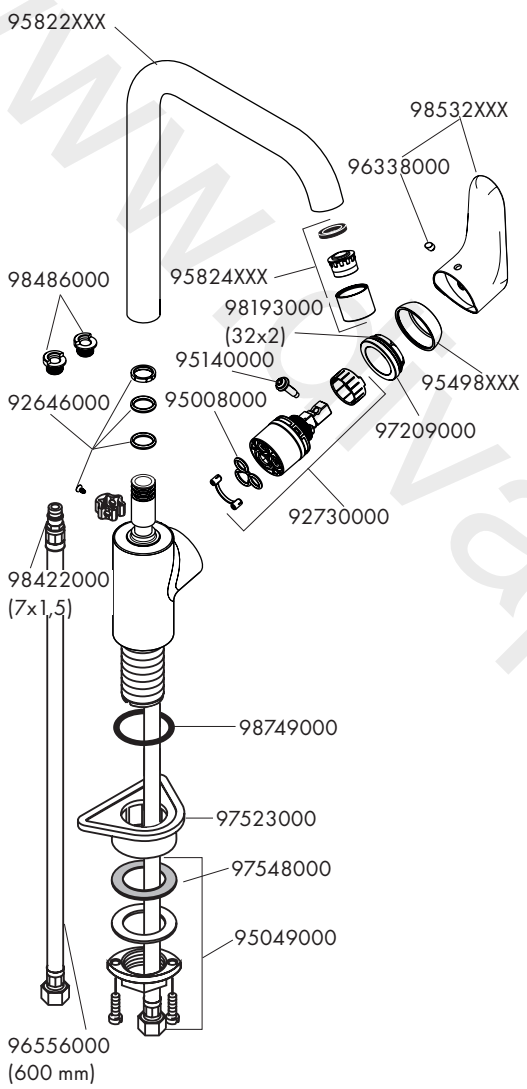



P-IX

DVGW SINTEF NF



ETA



GODKENDT  
TIL DRIKKEVAND

	P-IX	DVGW SINTEF NF	STF	ETA
<b>31817XXX</b>	P-IX 28097/IO	CT0437	X	X
<b>31820XXX</b>	P-IX 6993/IA	CT0437	X	X
<b>31827XXX</b>				
<b>31834XXX</b>			X	

