

GROHE RED MONO
DESIGN + ENGINEERING
GROHE GERMANY

99.134.231/ÄM 230155/06.14

www.grohe.com

Pure Freude an Wasser

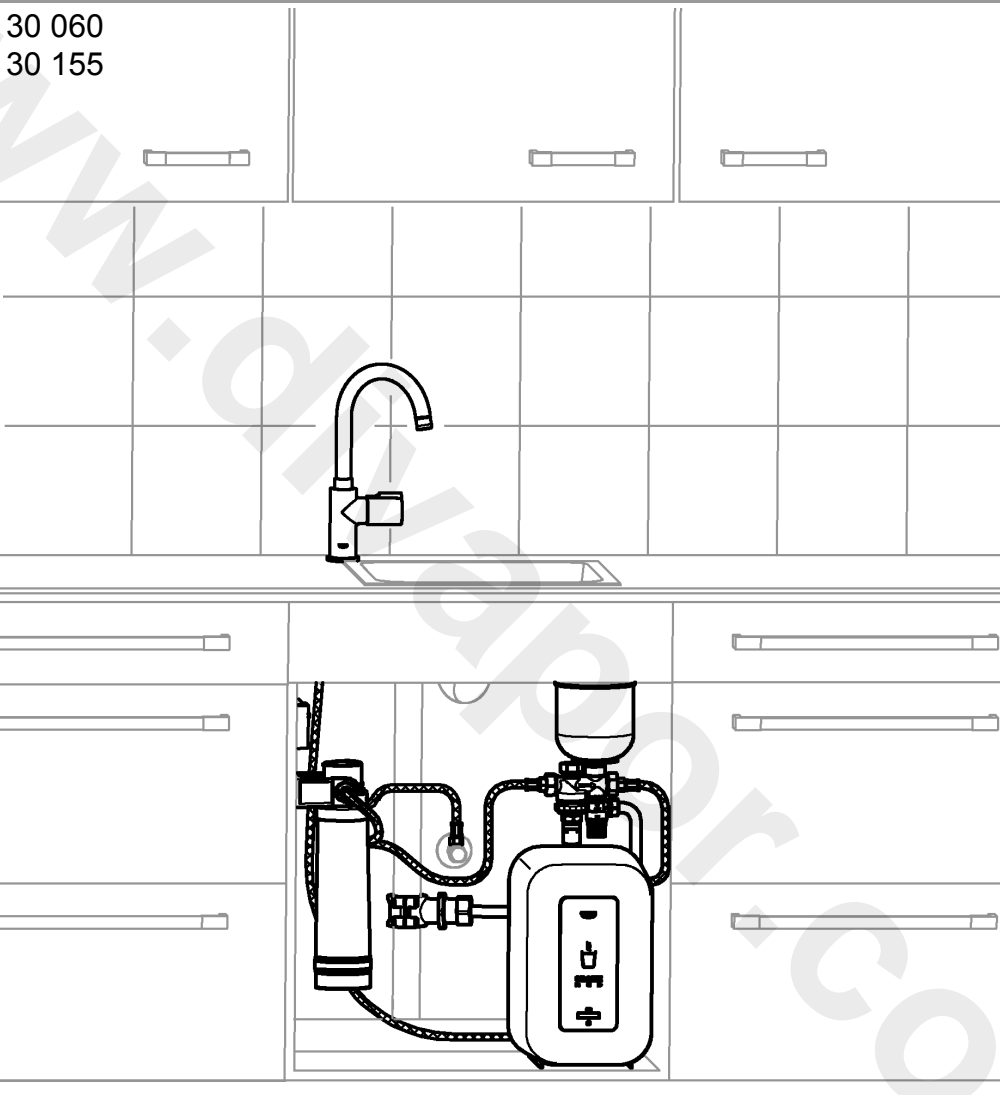

GB1

30 060

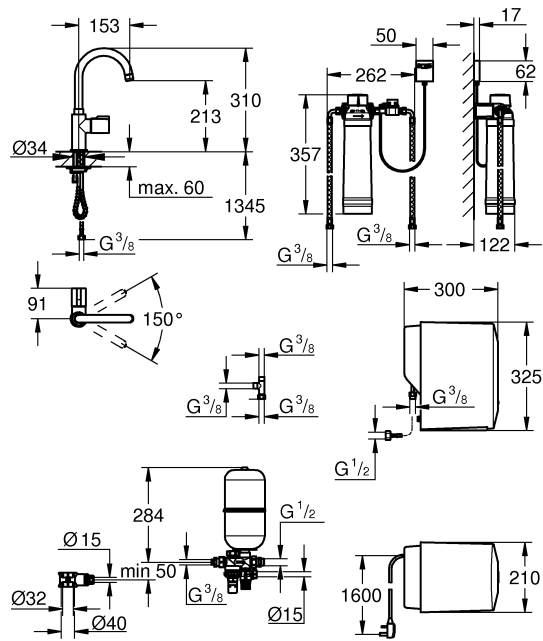

30 155

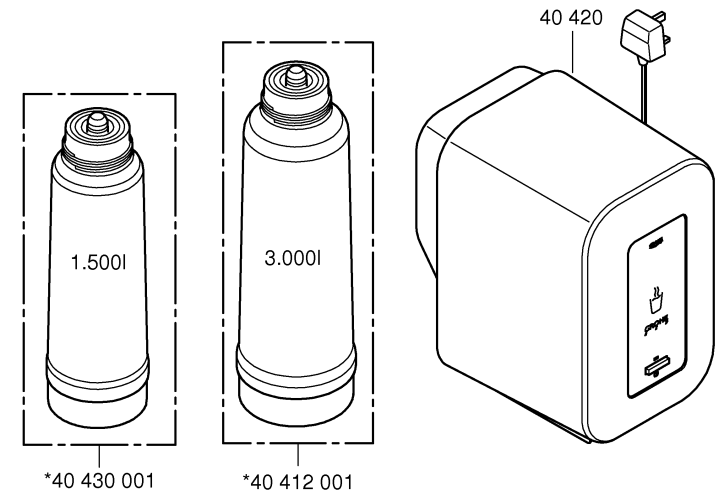
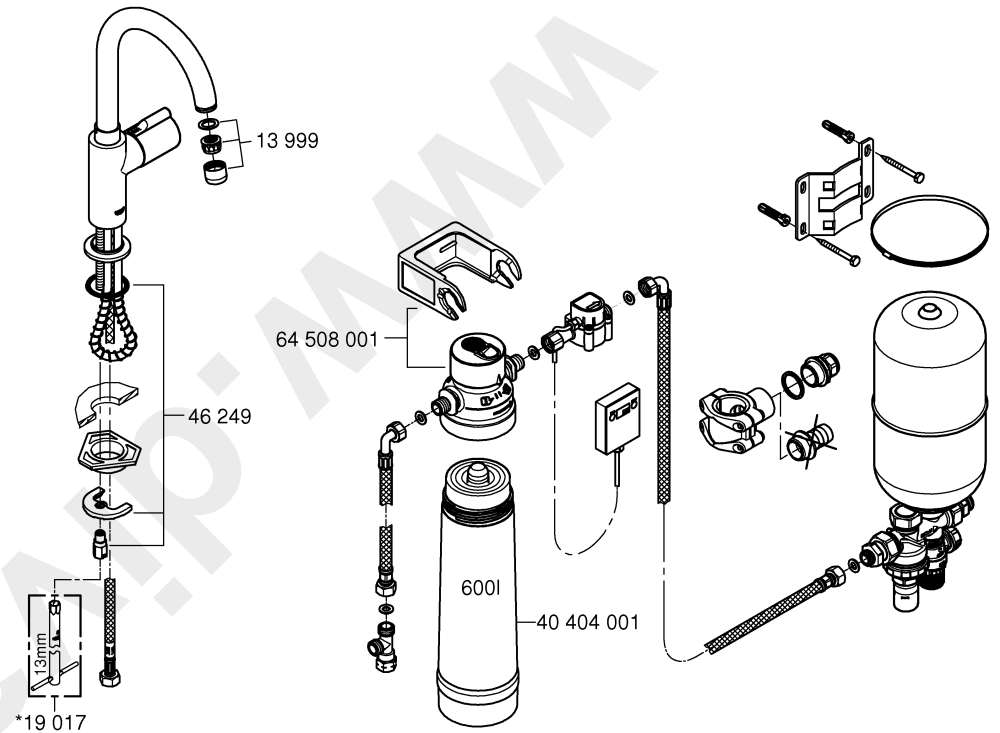
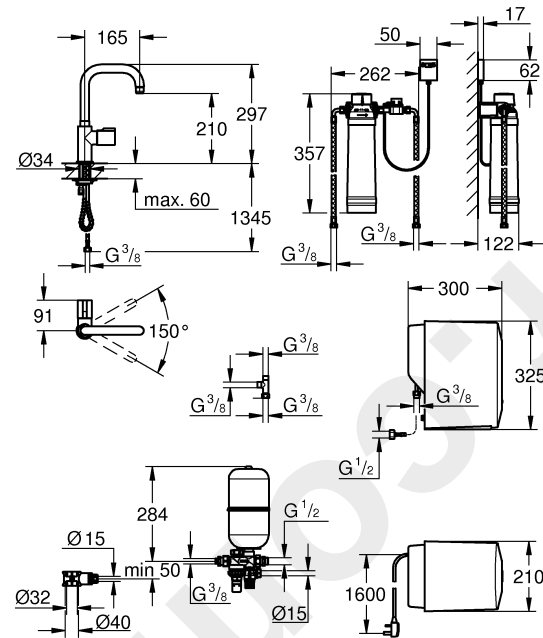

Please pass these instructions on to the end user of the fitting!



Type approvals

The GROHE Red boiling water storage heater with filter system must be installed the safety assembly with expansion vessel provided.

The boiling water storage heater with filter system may only be operated together with an original GROHE Red boiling water fitting.

Application

The GROHE boiling water storage heater is designed to heat and store drinking water in pressurised systems.

The GROHE boiling water storage heater is suitable for connection to a mains system with a maximum water pressure of 0.8 MPa.

It must **not** be connected to hot water.

The filter system measures the flow rate using a sensor and from this calculates the remaining capacity of the filter cartridge as a function of the set litre capacity. If the filter cartridge litre capacity set on the display unit is exceeded, the values are displayed as negative values.

The sensor also monitors the maximum service life of the filter cartridge. If the maximum service life of 12 months is exceeded, the remaining capacity of the filter cartridge flashes.

The water filtrate is classified as Category 2 according to EN 1717.

Safety notes

GROHE Red boiling water storage heater:



This device is not intended for use by persons (including children) with physical, sensory or mental impairments or a lack of experience or knowledge in using devices of this type.

Children must be supervised to ensure that they do not play with the device.



Risk of electric shock. Avoid damaged power supply cable. In case of damage, the boiling water storage heater must be replaced by the manufacturer or its customer service department or an equally qualified person.



Caution, risk of scalding! Escaping water is boiling hot. **Never touch the end of the spout** in order to swivel the spout as it becomes extremely hot.

- The boiling water storage heater must be connected to a permanent power supply with earth wire.
- Installation is only possible in frost-free rooms.
- The boiling water storage heater is only suitable for indoor use.
- The boiling water storage heater must be placed in an upright position.
- The boiling water storage heater and plug must **not** be directly or indirectly sprayed with water when cleaning.
- The boiling water storage heater must not be opened.
- Use **only genuine replacement parts and accessories**. The use of other parts will result in voiding of the warranty and the CE identification, and could lead to injuries.

If the boiling water storage heater is to be drained, the safety assembly with expansion vessel of the boiling water storage heater must be removed. Invert the boiling water storage heater and allow the water to run out.

However, we strongly advise against draining the boiling water storage heater. There is a significant risk of damaging the boiling water storage heater.

Technical data

Electrical data boiling water storage heater:

- Connection: Wall socket with earth wire, protected via a 13 A fuse
- Voltage supply: 230 V AC / 50 Hz
- Power consumption: 2100 W
- Standby power loss (switched on): 15 W
- Standby power loss (switched off): 1 W
- Type of protection: IPX4

Filter system:

- Sensor battery: 3 V lithium battery (type CR 2032)
- Display unit rating (wall installation): IPX4
- Sensor rating: IPX8

Sanitary data boiling water storage heater, fitting:

- Boiling water storage heater capacity: 4 l
- Flow pressure:
 - min. 0.1 MPa
 - recommended 0.1 – 0.5 MPa
- Operating pressure: max. 0.2 – 0.8 MPa
- Test pressure: 1.6 MPa
- Flow rate at 0.3 MPa flow pressure: approx. 3.0 l/min
- Boiling water temperature 99 °C
- The actual temperature may differ slightly due to different ambient pressures
- Heating time from 10 °C to 99 °C: approx. 15 min
- Available storage heater volume at 99 °C: 3 l/min
- Max. chlorine value: 100 mg/l
- Water connection at storage heater: Cold water
- Water connection at fitting: Boiling water from storage heater

New Water Regulations

Please ensure installation complies with New Water Regulations. It must also be installed in accordance with local bye-law requirements.

Approval and conformity

 This product conforms to the requirements of the relevant EU guidelines.

The conformity declarations can be obtained from the following address:

GROHE Deutschland Vertriebs GmbH

Zur Porta 9
D-32457 Porta Westfalica

Electrical installation



Electrical installation work must only be performed by a qualified electrician. This work must be carried out in accordance with the regulations according to IEC 60364-7-701 (corresponding to VDE 0100 Part 701) as well as all national and local regulations.

- Extension cables are **not** permitted between the electrical socket and boiling water storage heater connection.

Installation

Refer to the dimensional drawing on fold-out page I.

Installing fitting, see fold-out page II, Figs. [1] and [2].

Insert fitting in sink hole. This will require leading through the hoses one at a time.

Note: If there is no need to fit support plate (A), the clamping length may be increased by 15mm, see Fig. [1].

Mount safety relief valve kit to the waste pipe, see Figs. [3] to [6].

Mount wall holder, see Figs. [7] and [8].

Mount compression couplings (B) and tighten nipple, see Fig. [9].

Fix expansion vessel (C) with safety assembly to the wall holder, see Fig. [10].

Connect filter head and filter, see technical product information for the filter head and the filter cartridge and Figs. [11] and [12]. Note direction of flow.

1. Install pressure hose (D) to the inlet of filter head, see Fig. [11].
2. Install sensor (E) at outlet of filter head. The sensor (E) must be installed horizontally.
3. Install display unit (F).
Use suitable screws and wall plugs (not included in the scope of delivery).
4. Screw hose (G) onto sensor (E), see Fig. [12].

Flush pipes thoroughly before and after installation (observe EN 806).

Connect filter system to service valve, see fold-out page III, Fig. [13a] or [13b].

Only GROHE Red Mono

- Screw pressure hose (D) of filter system on the cold-water service valve, see Fig. [13a].

Only GROHE Red Mono in combination with kitchen fitting

- Screw pressure hose (D) of filter system with adapter (H) to the cold-water service valve, see Fig. [13b].

Connect storage heater, see Figs. [2] and [14].

Install storage heater taking into consideration the available hose lengths.

Do not connect voltage supply yet.

1. Connect expansion vessel (C), see Fig. [14].
2. Screw hose (G) to expansion vessel (C).
3. Screw storage heater pressure hose (I) marked **blue** to expansion vessel (C).
4. Connect copper pipe (not in the scope of delivery) to the Ø15mm compression connection (J) of the expansion vessel (C) and tighten.

Connecting fitting, see fold-out page III, Fig. [15].

- Connect the fitting pressure hose (M) marked **99 °C** to connection (N) on the storage heater.

Open the service valve and check connections for watertightness.

Filling storage heater with water, see Figs. [16] and [17].

1. Pull button (O1) on handle (O) of fitting outward and turn the handle anti-clockwise, see Fig. [16].
2. Fill the storage heater until water comes out the spout of the fitting.
3. Connect voltage supply via mains plug (P), see Fig. [17].
4. Press and hold button (Q) on storage heater for at least 2 seconds to switch on the storage heater. The red indicator lamp (Q1) indicates that the storage heater is switched on.

Important!

The spout must not be fitted with any downstream resistances in the form of air bubblers (e.g. mousseurs) or components reducing flow (e.g. restrictors) as these will result in damage to the storage heater.

Set water hardness at filter head, see fold-out page IV, Fig. [18].











Set water hardness at bypass setting of filter head to local conditions, see table column **A** on page 4.

The relevant water supplier can provide information on the water hardness.

The bypass value set to the filter head must also be set as litre specification on the display unit (F), see Fig. [19].

Setting the litre specification (factory setting is 600 litre), see Fig. [19].

The value for the litre specification depends on the water hardness as per table column **B** on page 4:

Button		Display
PROG. 	Briefly press PROG button (PRG flashes)	
RESET 	Briefly press RESET button to access programming for litre specification (00000 flashes)	
PROG. 	Keep pressing PROG button until required position is reached (00000 digit flashes)	
RESET 	Keep pressing RESET button until required digit is reached (00600 digit flashes)	
PROG. 	Keep pressing PROG button to exit menu (PRG disappears and set value appears)	

The GROHE Red boiling water system is now fully installed and ready for operation.



The date of installation must be noted on the maintenance sticker and affixed at a visible location on the storage heater.

Operating the fitting

Note:

In order to prevent incorrect operation and for protection against injury, we recommend affixing the sticker provided.

Pull button (O1) on handle (O) outward and turn and hold handle (O) anti-clockwise to draw boiling water, see fold-out page III, Fig. [16]. Handle (O) closes automatically.

Press and hold **button (Q)** for at least 2 seconds to switch the storage heater on or off, see Fig. [17].

Maintenance



In the case of interventions in the mains supply or maintenance work, the GROHE Red boiling system must be bled as steam jets could otherwise occur.

Close the service valve, switch off the storage heater and disconnect the mains plug.

Wait until the storage heater and fitting have cooled down. Open the lever to depressurise the storage heater.

Inspect and clean all parts, replace as necessary and lubricate with special grease.

I. Filter

See technical product information of filter cartridge for information on replacing the filter cartridge.

Resetting the filter capacity at the display unit (F), see fold-out page IV, Fig. [19].

After a new filter cartridge is inserted, the filter capacity must be reset as follows:

Button		Display
	Display flashing (negative litre specification, e.g. -1 or remaining capacity e.g. 150 flashing)	
RESET 	Press RESET button for 3 seconds (rESEt appears)	
	The data for time and litre capacity is reset	

Note: The litre specification programmed for the filter cartridge is retained.

Battery (F1), see fold-out page IV, Fig. [20] and [21].

The battery must be replaced 7 years after commissioning the fitting, at the latest.

Button		Display
	BATT display flashes (battery is discharged and needs to be replaced)	

1. Loosen screw (F2) and remove cover (F3), see Fig. [20].

2. Remove battery (F1) and replace, see Fig. [21].

Important: Note correct polarity.

Note: No settings saved by the user will be lost when changing the batteries or if the battery discharges.

Assemble in reverse order.

II. Flow straightener

Remove and clean flow straightener (13 999), see fold-out page I.

Assemble in reverse order.

Service

Note the **Fault/Cause/Remedy** table for information on eliminating problems.

If the problem cannot be rectified, disconnect the mains plug to shut off the voltage supply. Note down the serial number of the storage heater on the rear of the device and get in touch with GROHE Customer Service or contact the GROHE Service Hotline under **TechnicalSupport-HQ@grohe.com**.

The GROHE Red boiling water storage heater cannot be repaired. If servicing is required, the complete storage heater **must** be replaced.

In order to ensure correct operation, maintenance **must** be performed on all hot-water-bearing parts by GROHE Customer Service every five years.

Following any service/maintenance work, the boiling water storage heater must be re-filled, see section **Installation**.



The date of maintenance must be noted on the maintenance sticker on the storage heater.

Replacement parts

See fold-out page I (* = special accessories).

Care

For directions on the care of this fitting, please refer to the accompanying Care Instructions.

Disposal



This category of devices does **not** belong in the domestic waste, but must be disposed of separately in accordance with the relevant local national regulations.

Carbonate hardness				Bypass	Litre capacity		
				A	B		
					40 404 001	40 430 001	40 412 001
≤ 9 (°KH)	≤ 16 (°fH)	≤ 3,38	≤ 1,69	3	1.600 l	4.000 l	6.500 l
10 - 24 (°KH)	17 - 43 (°fH)	3,39 - 8,75	1,7 - 4,37	2	600 l	1.500 l	2.300 l
25 - 29 (°KH)	44 - 52 (°fH)	8,76 - 10,35	4,38-5,22	1	350 l	1.000 l	1.500 l
≥ 30 (°KH)	≥ 53 (°fH)	≥ 10,36	≥ 5,33	0	250 l	650 l	1.000 l

Fault	Cause	Remedy
Water too cold	<ul style="list-style-type: none"> Empty storage heater switched on ('On' indicator lamp flashes) Heating phase not yet complete 	<ul style="list-style-type: none"> Fill the storage heater, see section Installation Reset the storage heater by pressing the reset button (X) located on the rear of the storage heater using a thin object, see fold-out page IV, Fig. [22] Wait max. 15 minutes
Flow rate too low	<ul style="list-style-type: none"> Fitting flow straightener dirty or defective Isolating valve not fully open Water supply restricted 	<ul style="list-style-type: none"> Replace flow straightener, see section Maintenance Fully open shut-off valves, isolating valves Check supply lines, open isolating valve
Water not boiling	<ul style="list-style-type: none"> Storage heater not hot enough yet 	<ul style="list-style-type: none"> Wait approx. 15 minutes after switching on
Storage valve losing water	<ul style="list-style-type: none"> Hose connection or internal tank leaking 	<ul style="list-style-type: none"> Switch off the storage heater, disconnect the mains plug and contact GROHE Customer Service
Splashy, irregular spray	<ul style="list-style-type: none"> Fitting flow straightener dirty or defective 	<ul style="list-style-type: none"> Replace flow straightener, see section Maintenance
Fitting running continuously	<ul style="list-style-type: none"> Handle not closing 	<ul style="list-style-type: none"> Close the isolating valves, switch off the storage heater, disconnect the mains plug and contact GROHE Customer Service

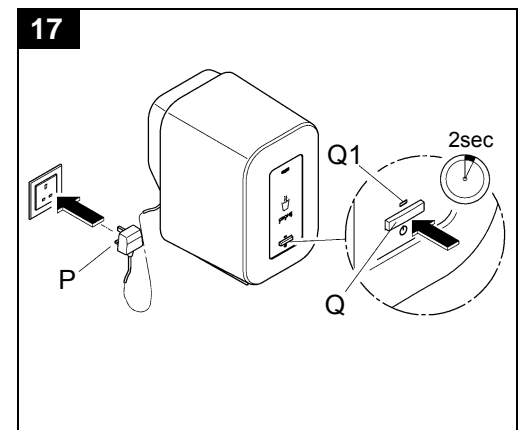
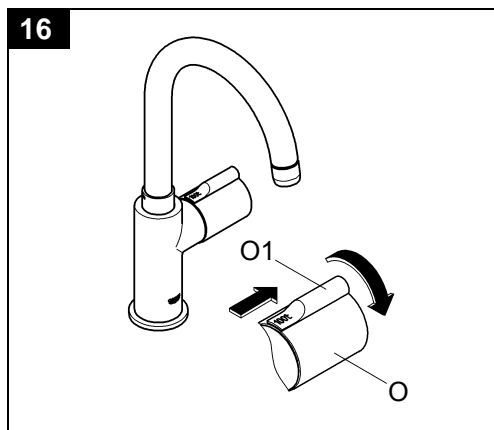
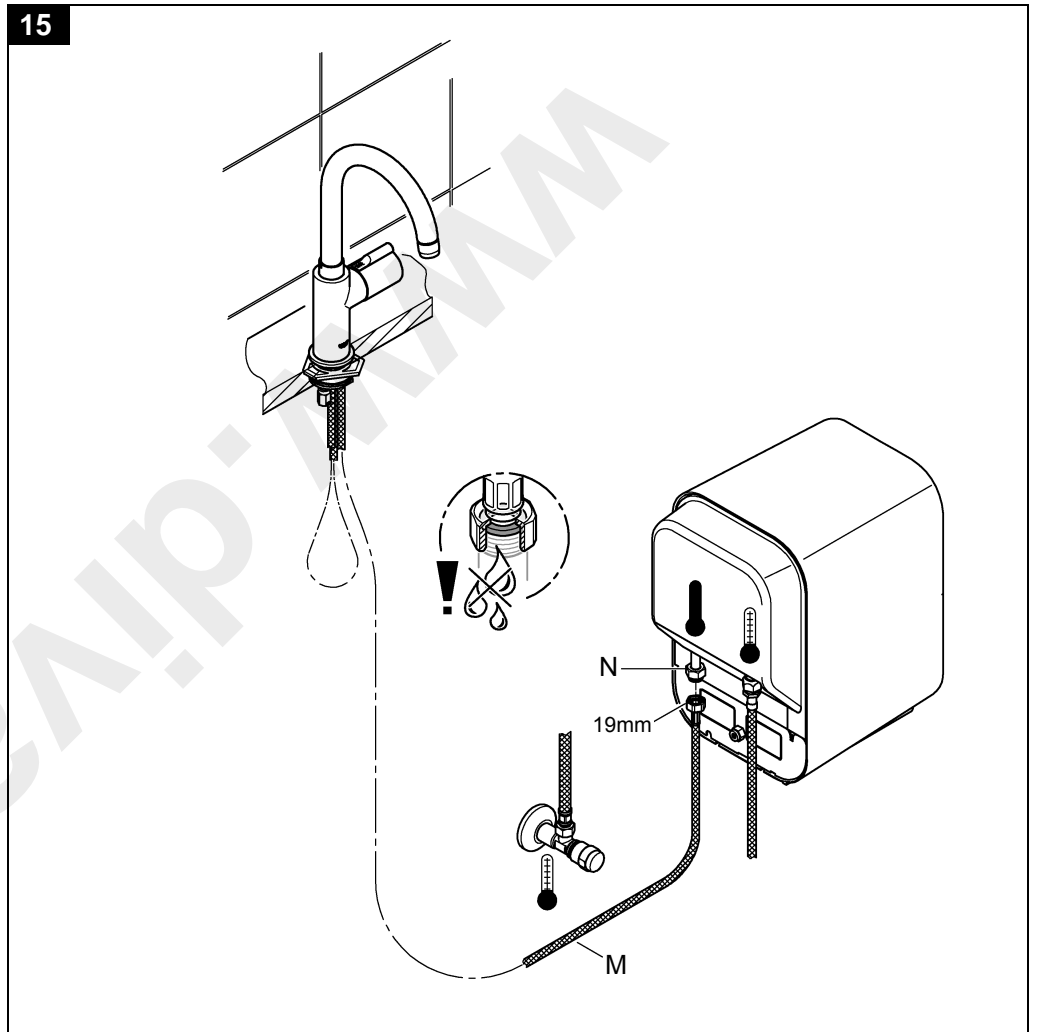
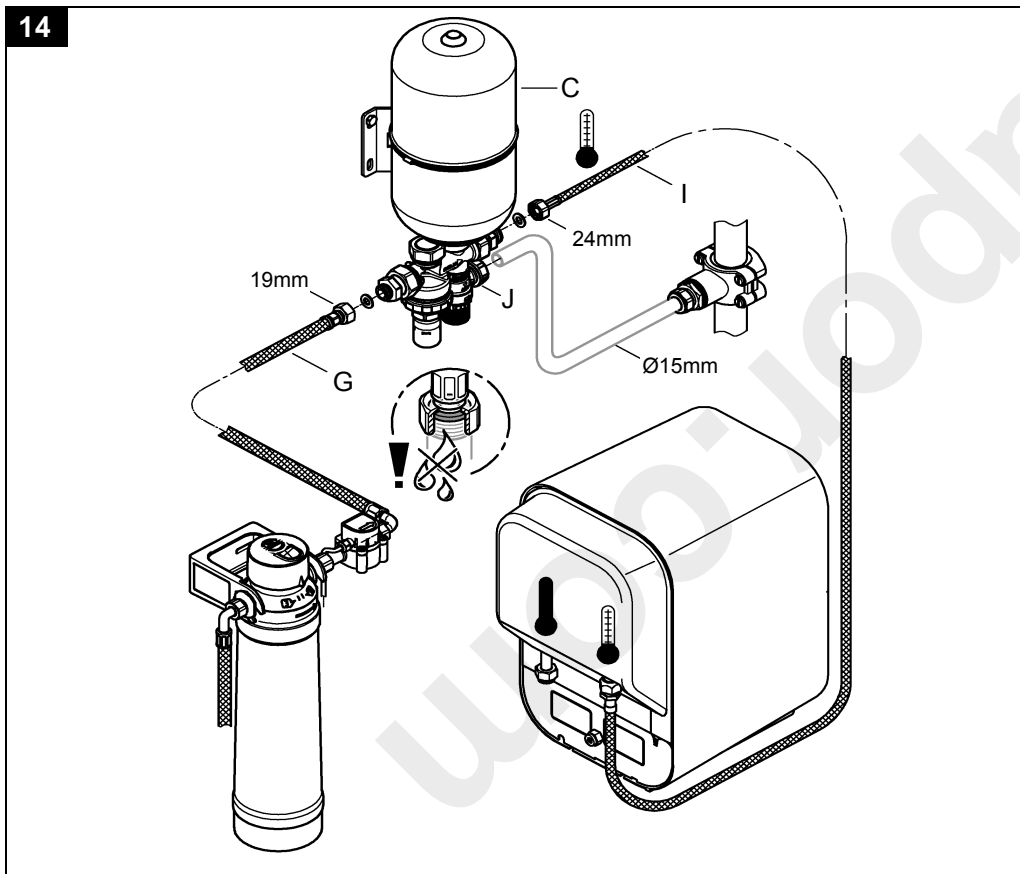
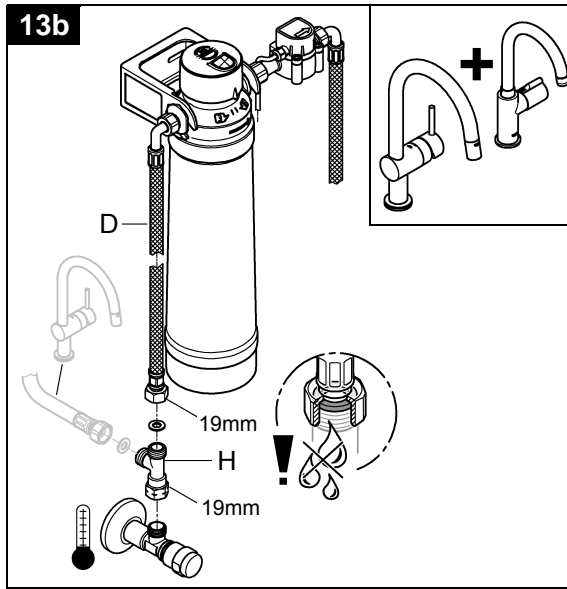
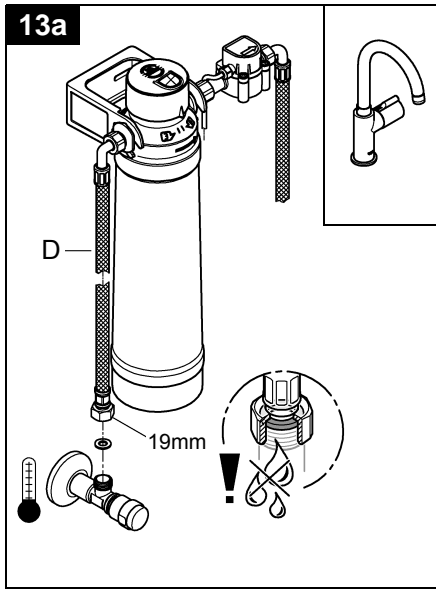

Pure Freude an Wasser

GROHE

(D)
☎ +49 571 3989 333
impressum@grohe.de

(A)
☎ +43 1 68060
info-at@grohe.com

(AUS)
Argent Sydney
☎ +(02) 8394 5800
Argent Melbourne
☎ +(03) 9682 1231

(B)
☎ +32 16 230660
info.be@grohe.com

(BG)
☎ +359 2 9719959
grohe-bulgaria@grohe.com

(CAU)
☎ +99 412 497 09 74
info-az@grohe.com

(CDN)
☎ +1 888 6447643
info@grohe.ca

(CH)
☎ +41 448777300
info@grohe.ch

(CN)
☎ +86 21 63758878

(CY)
☎ +357 22 465200
info@grome.com

(CZ)
☎ +420 277 004 190
grohe-cz@grohe.com

(DK)
☎ +45 44 656800
grohe@grohe.dk

(E)
☎ +34 93 3368850
grohe@grohe.es

(EST)
☎ +372 6616354
grohe@grohe.ee

(F)
☎ +33 1 49972900
marketing-fr@grohe.com

(FIN)
☎ +358 10 8201100
teknocalor@teknocalor.fi

(GB)
☎ +44 871 200 3414
info-uk@grohe.com

(GR)
☎ +30 210 2712908
nsapountzis@ath.forthnet.gr

(H)
☎ +36 1 2388045
info-hu@grohe.com

(HK)
☎ +852 2969 7067
info@grohe.hk

(I)
☎ +39 2 959401
info-it@grohe.com

(IND)
☎ +91 124 4933000
customer-care.in@grohe.com

(IS)
☎ +354 515 4000
jonst@byko.is

(J)
☎ +81 3 32989730
info@grohe.co.jp

(KZ)
☎ +7 727 311 07 39
info-cac@grohe.com

(LT)
☎ +372 6616354
grohe@grohe.ee

(LV)
☎ +372 6616354
grohe@grohe.ee

(MAL)
☎ +1 800 80 6570
info-singapore@grohe.com

(N)
☎ +47 22 072070
grohe@grohe.no

(NL)
☎ +31 79 3680133
vragen-nl@grohe.com

(NZ)
☎ +09/373 4324

(P)
☎ +351 234 529620
commercial-pt@grohe.com

(PL)
☎ +48 22 5432640
biuro@grohe.com.pl

(RI)
☎ +62 21 2358 4751
info-singapore@grohe.com

(RO)
☎ +40 21 2125050
info-ro@grohe.com

(ROK)
☎ +82 2 559 0790
info-singapore@grohe.com

(RP)
☎ +63 2 8041617

(RUS)
☎ +7 495 9819510
info@grohe.ru

(S)
☎ +46 771 141314
grohe@grohe.se

(SGP)
☎ +65 6 7385585
info-singapore@grohe.com

(SK)
☎ +420 277 004 190
grohe-cz@grohe.com

(T)
☎ +66 2610 3685
info-singapore@grohe.com

(TR)
☎ +90 216 441 23 70
GroheTurkey@grome.com

(UA)
☎ +38 44 5375273
info-ua@grohe.com

(USA)
☎ +1 800 4447643
us-customer-service@grohe.com

(VN)
☎ +84 8 5413 6840
info-singapore@grohe.com

(AL) (BIH) (HR) (KS)
(ME) (MK) (SLO) (SRB)
☎ +385 1 2911470
adria-hr@grohe.com

**Eastern Mediterranean,
Middle East - Africa
Area Sales Office:**
☎ +357 22 465200
info@grome.com

(IR) (OM) (UAE) (YEM)
☎ +971 4 3318070
grohedubai@grome.com

Far East Area Sales Office:
☎ +65 6311 3600
info@grohe.com.sg

www.grohe.com

2014/03/21