

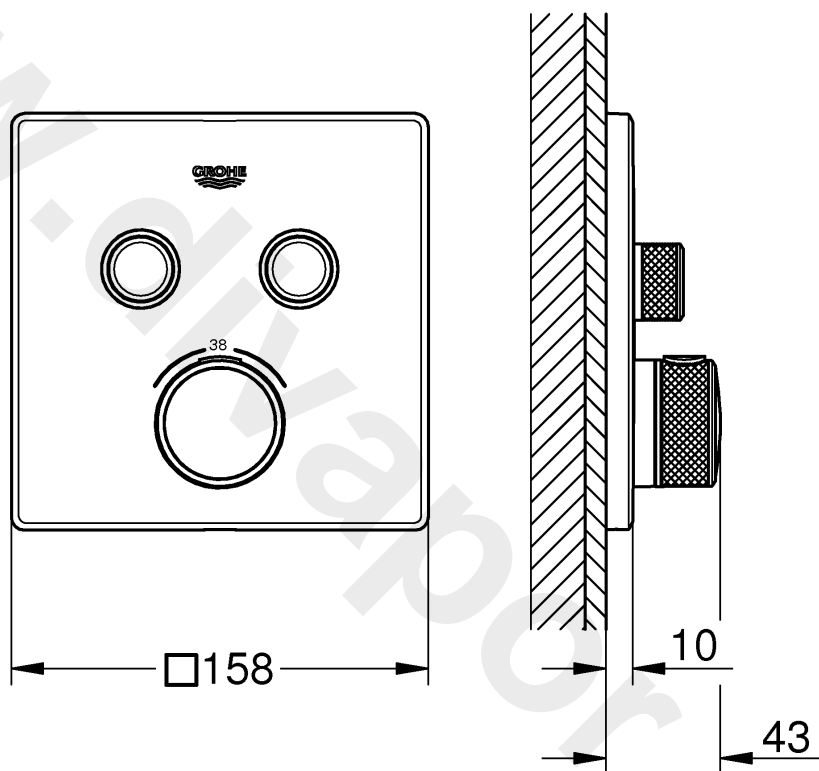

29 229



1



11

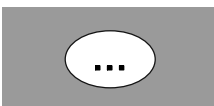

2 - 8

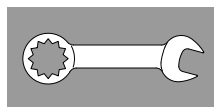

12



9 - 10



15



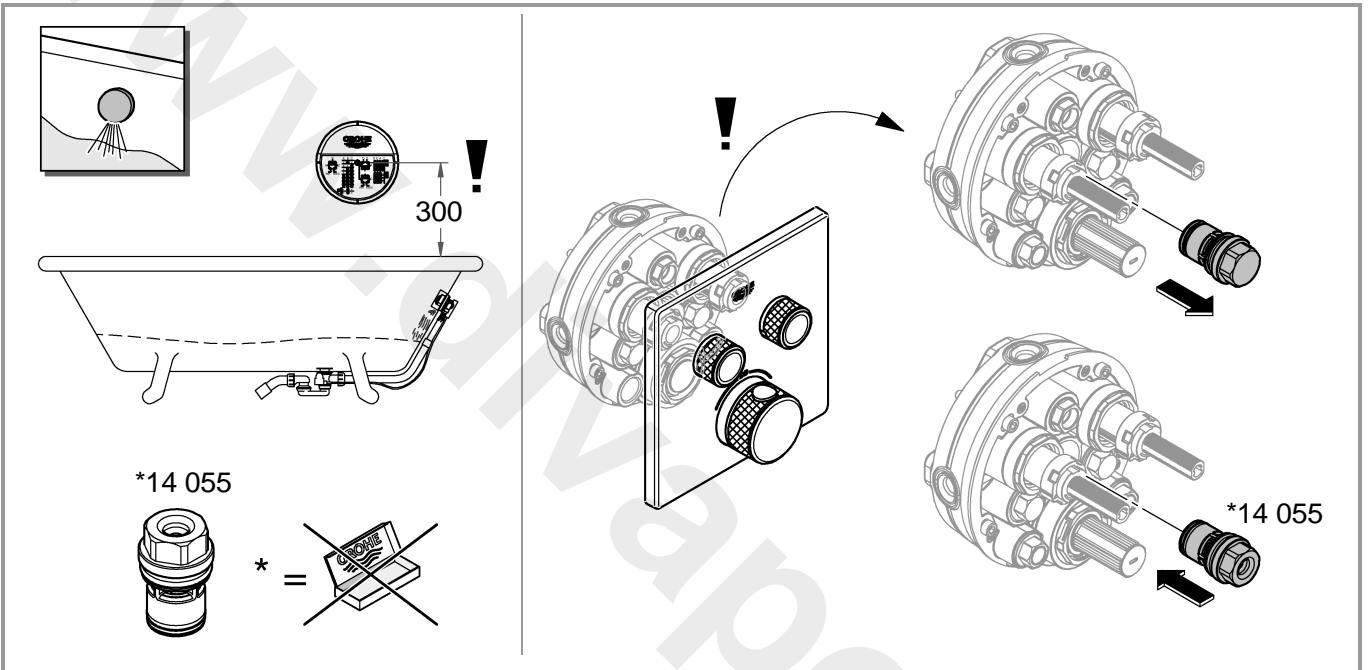
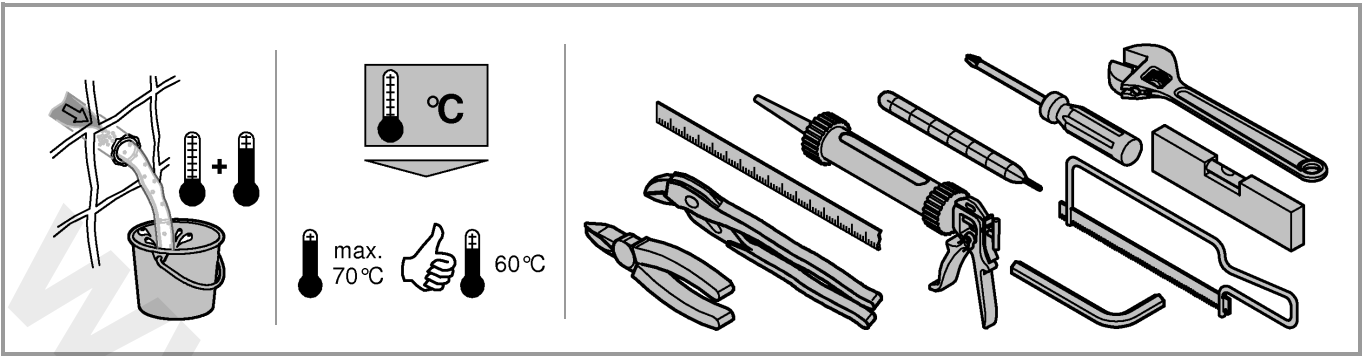

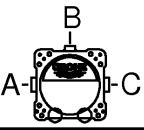
	kPa						l/min
	100	200	300	400	500	600	
B	13,9	19,6	24	27,7	31	33,9	
C	15	21,2	26	30	33,6	36,8	
B + C	16,7	23,7	29	33,5	37,4	41	

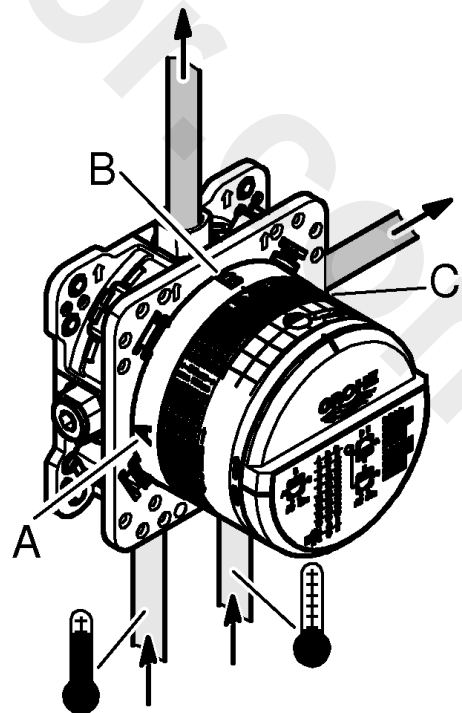





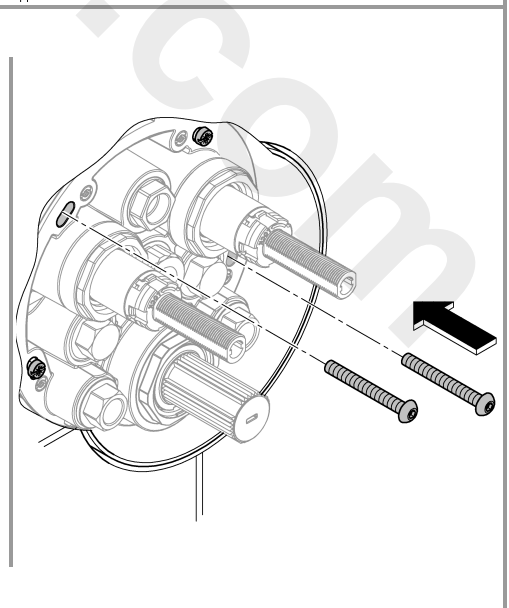
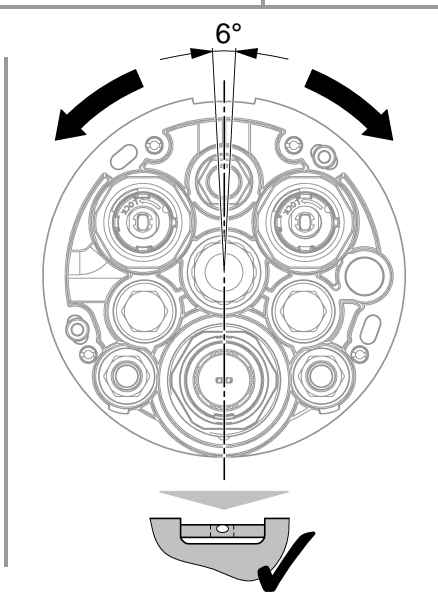
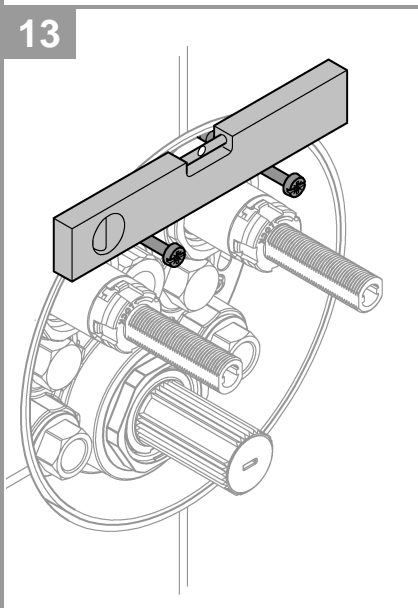
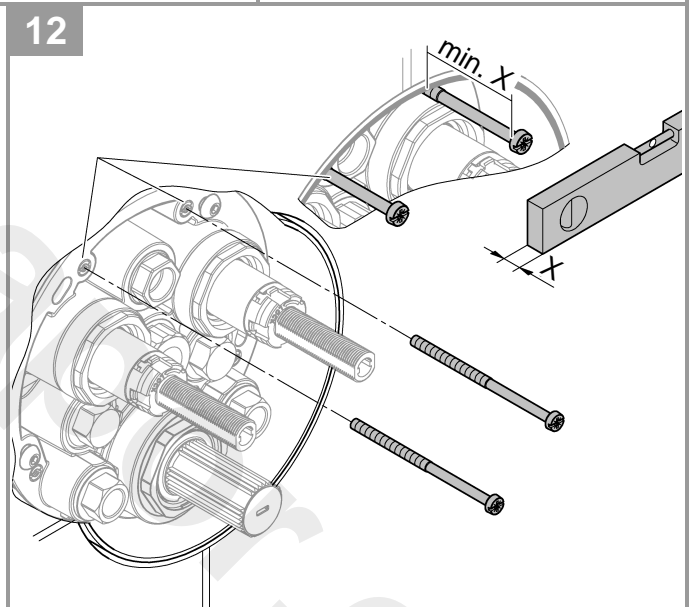
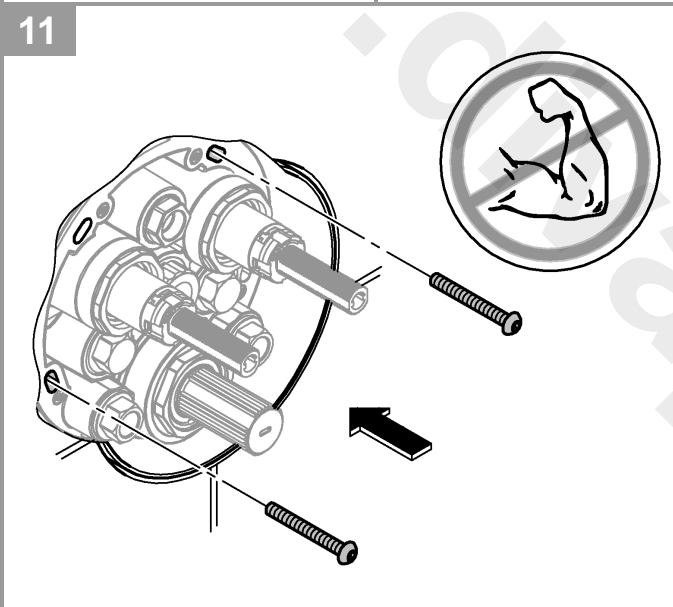
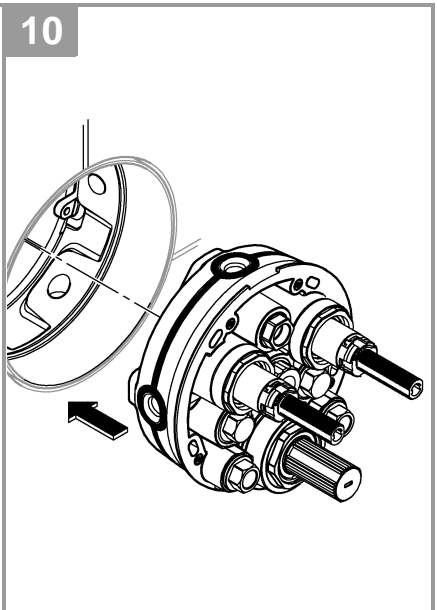
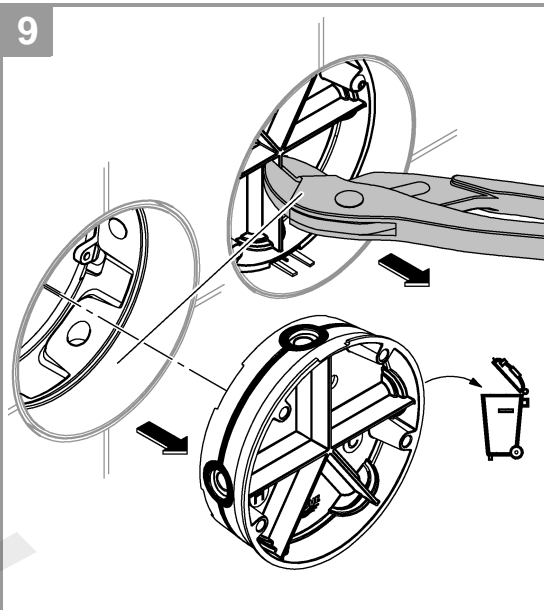
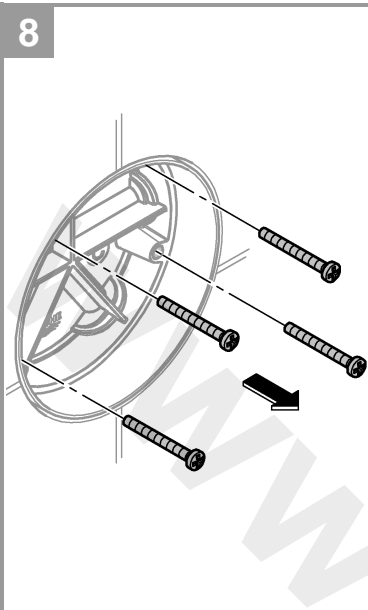

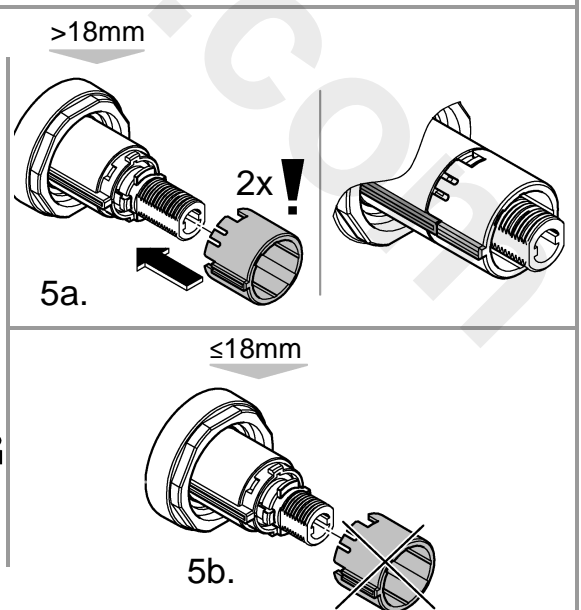
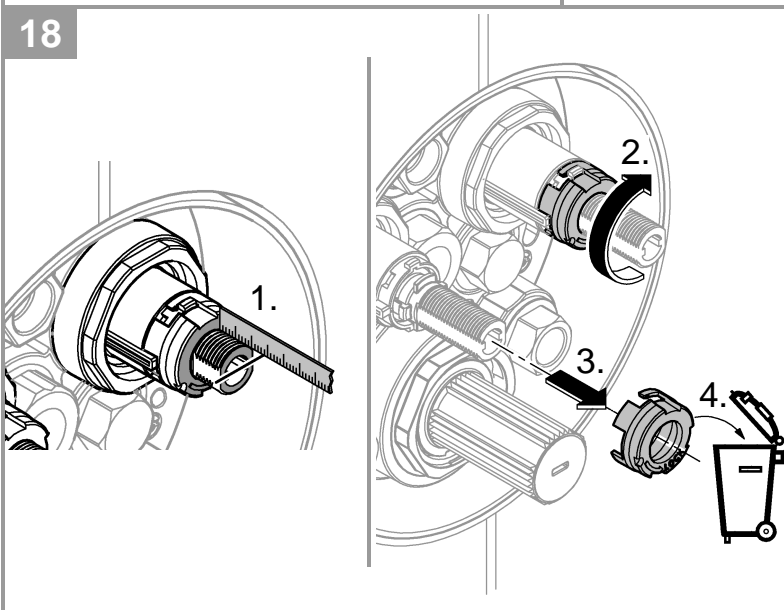
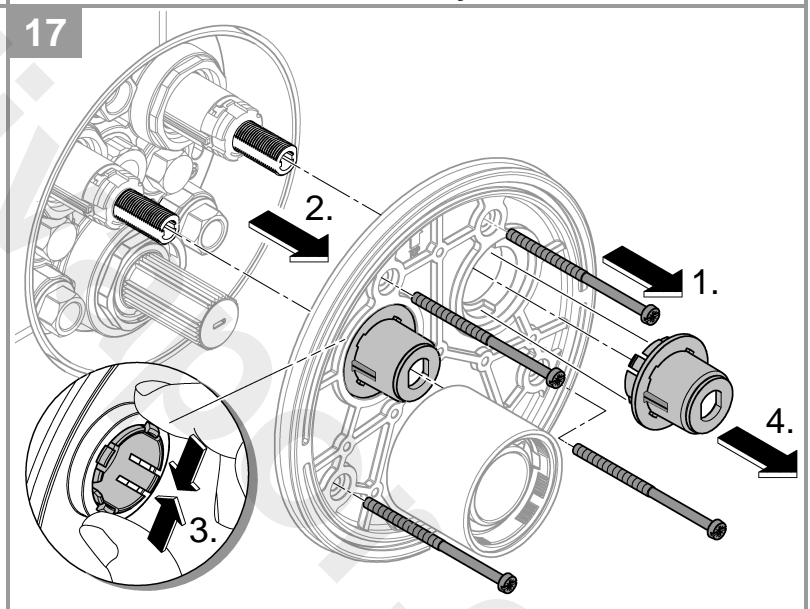
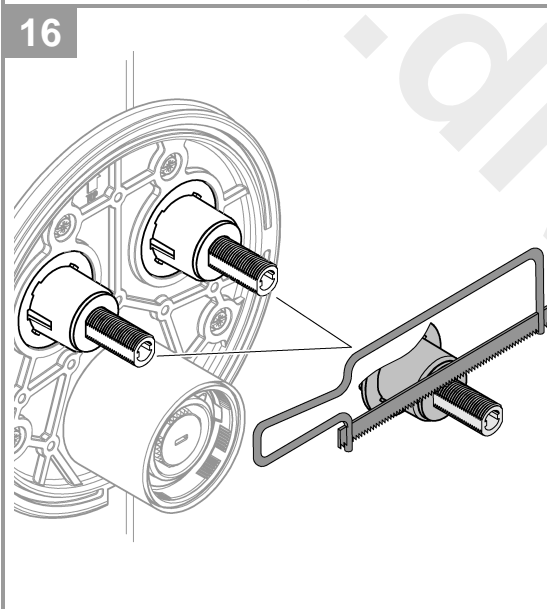
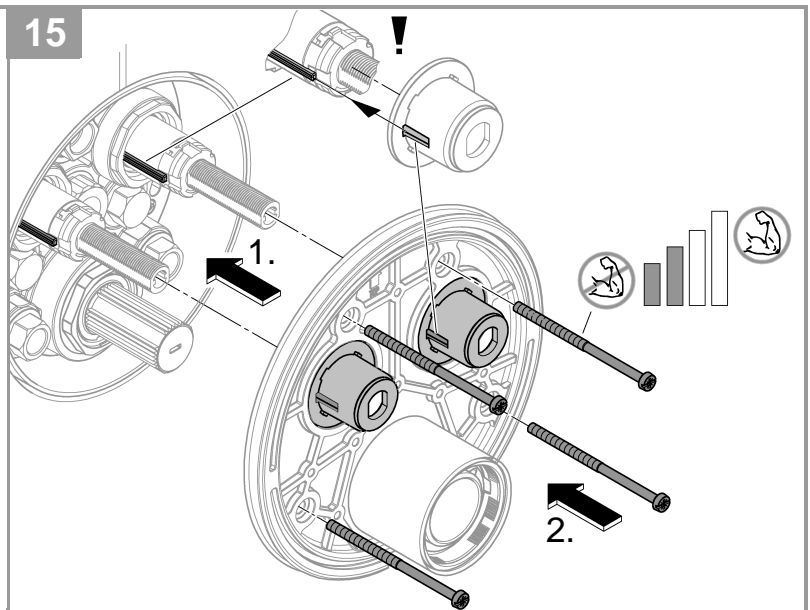
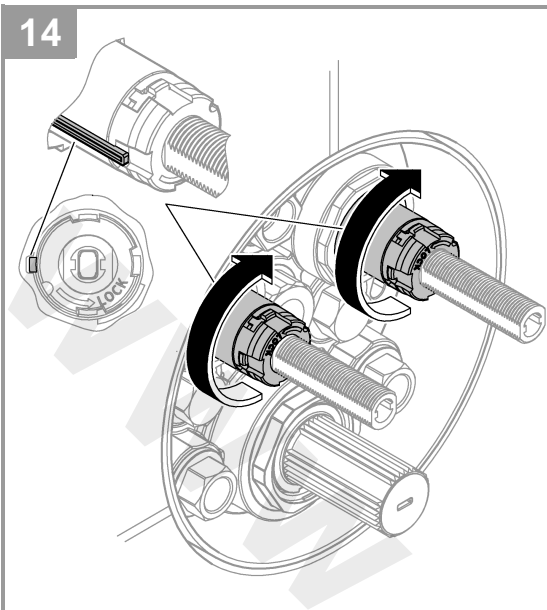



19

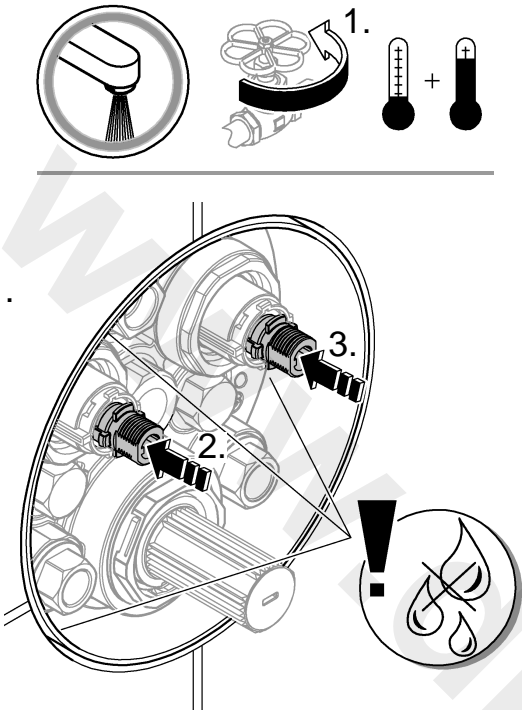

20

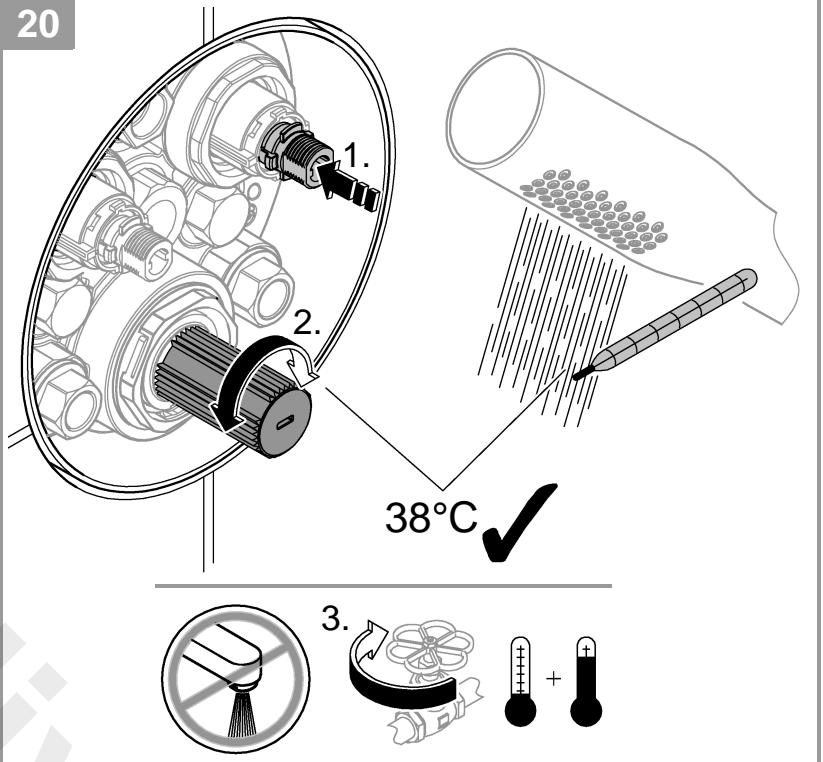

21

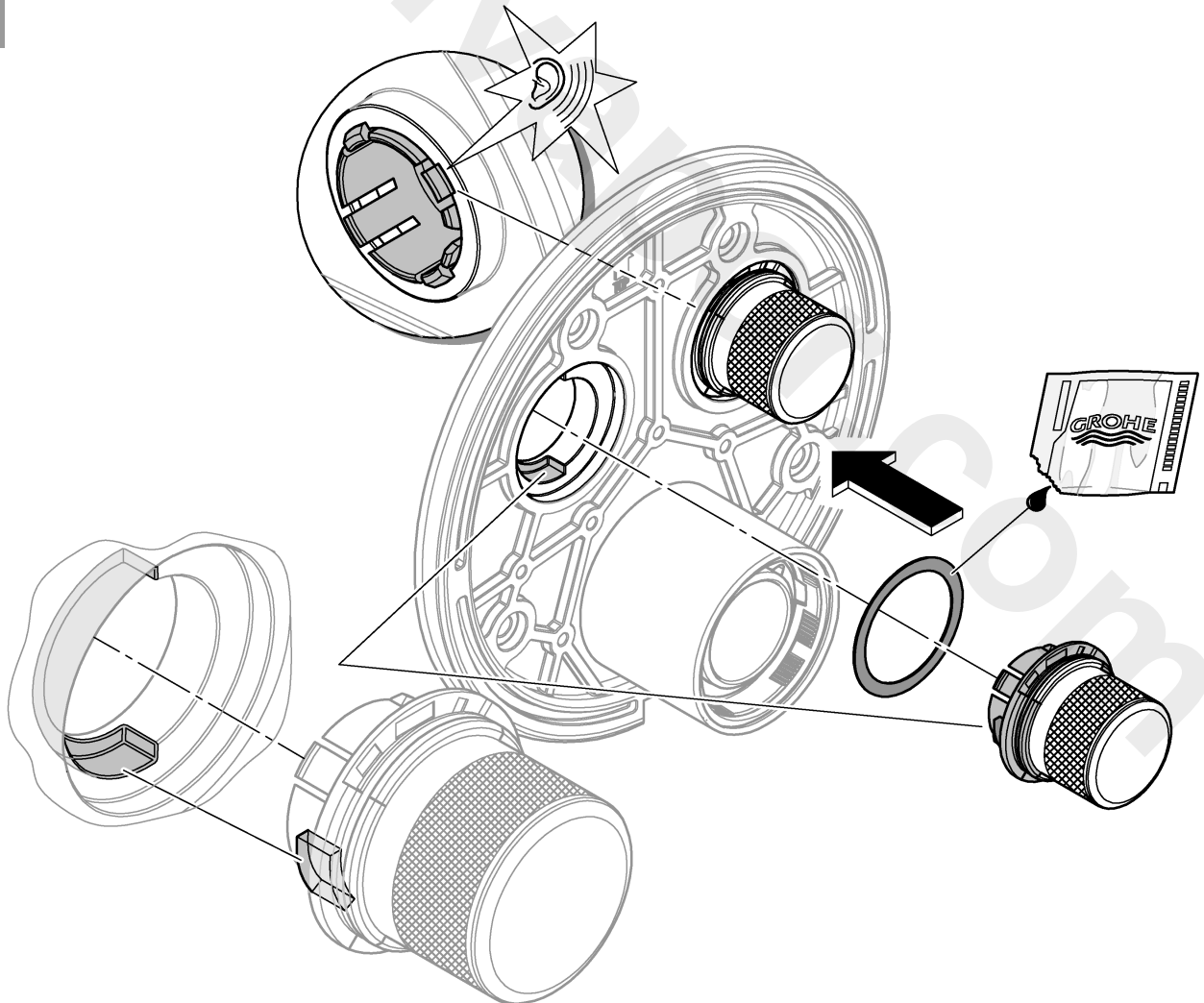



22

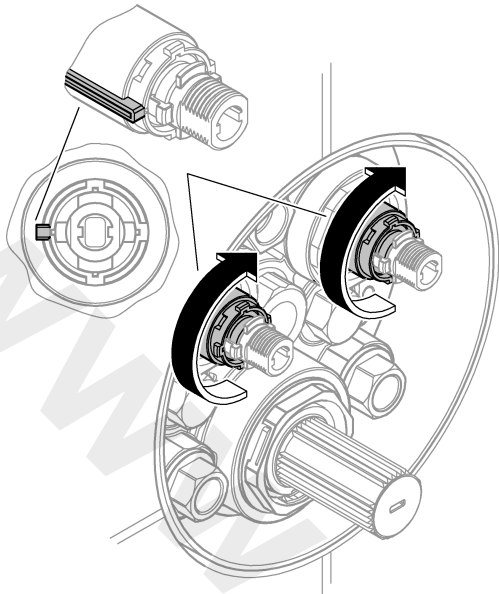

23

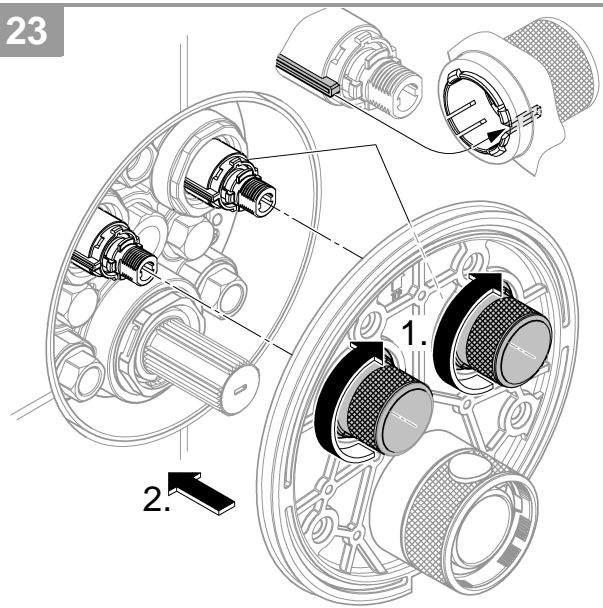

24

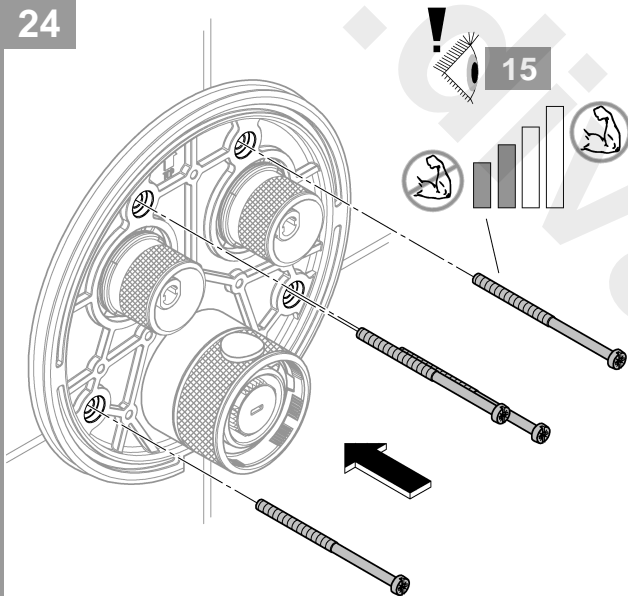

25

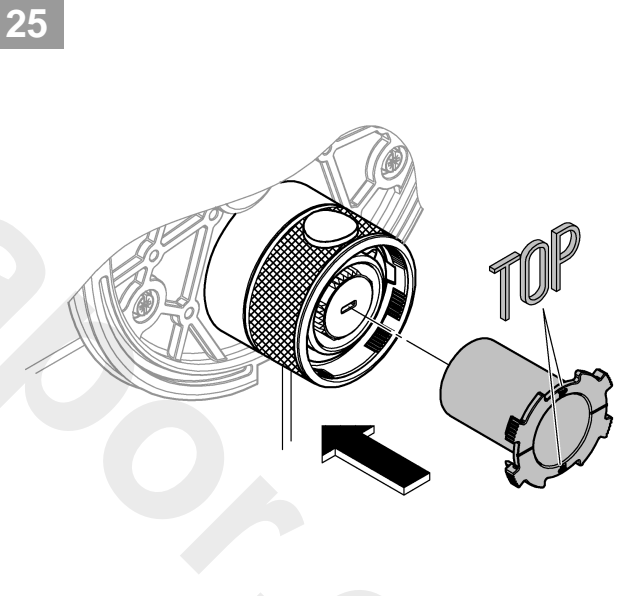

26

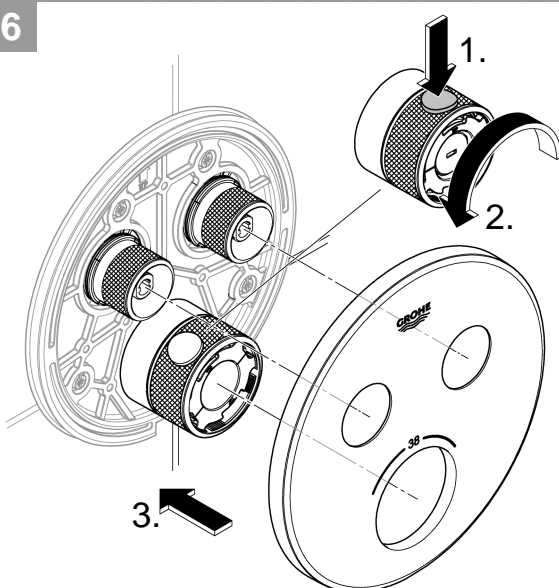

27

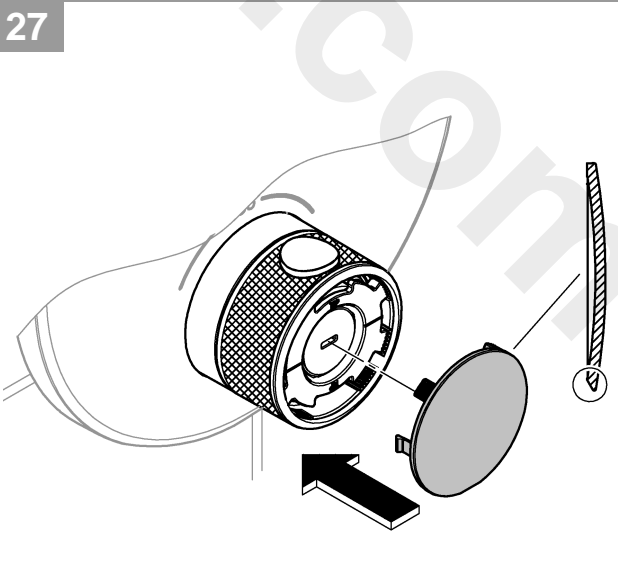



28

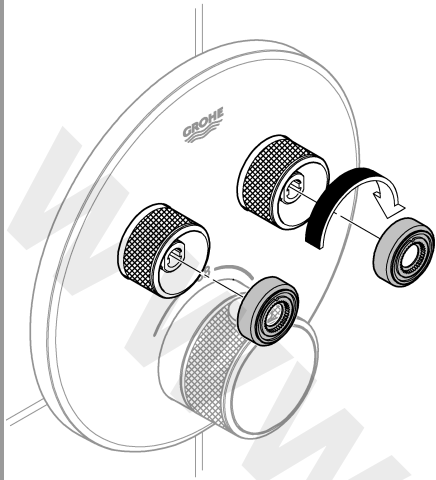

29

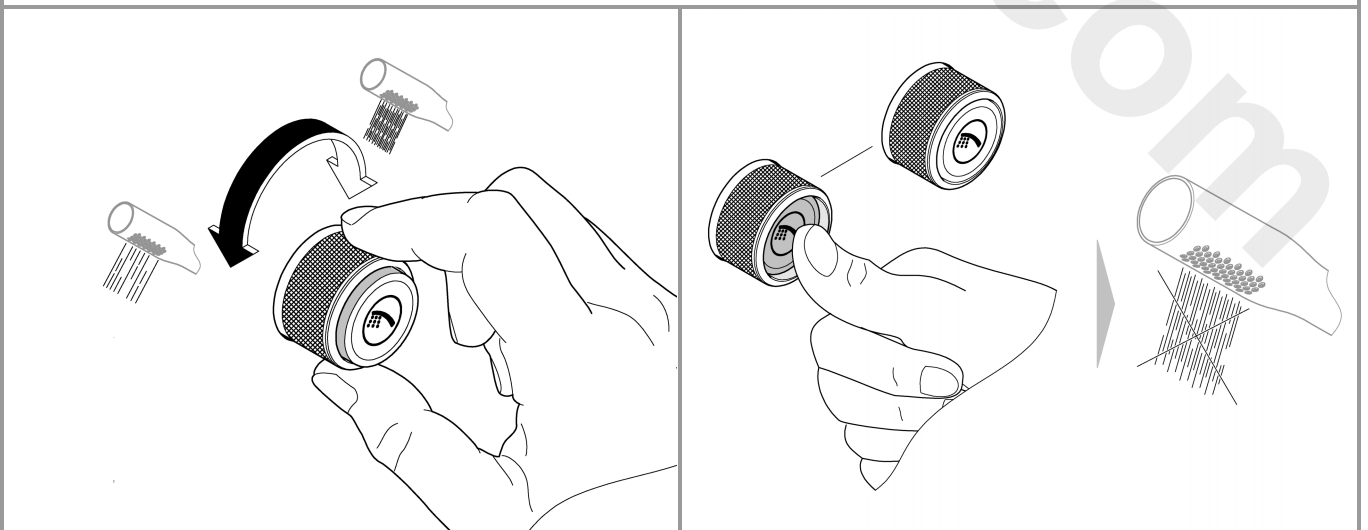
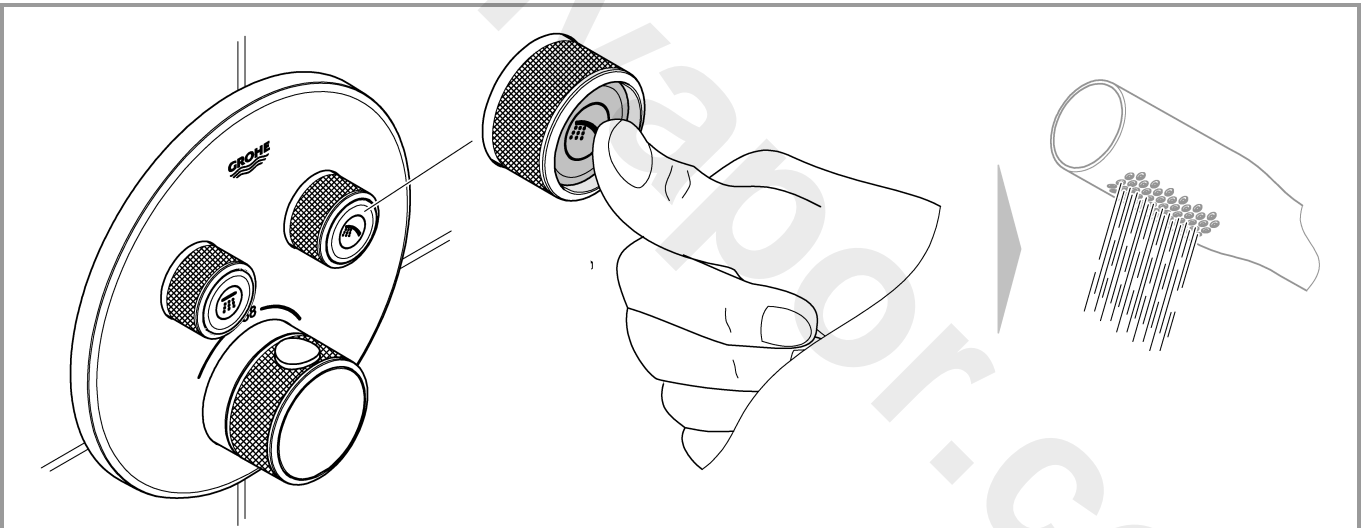
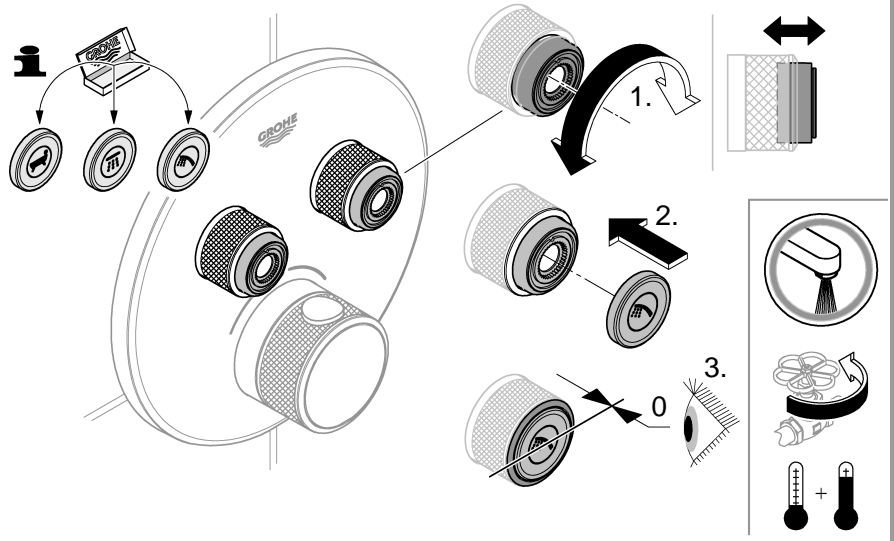

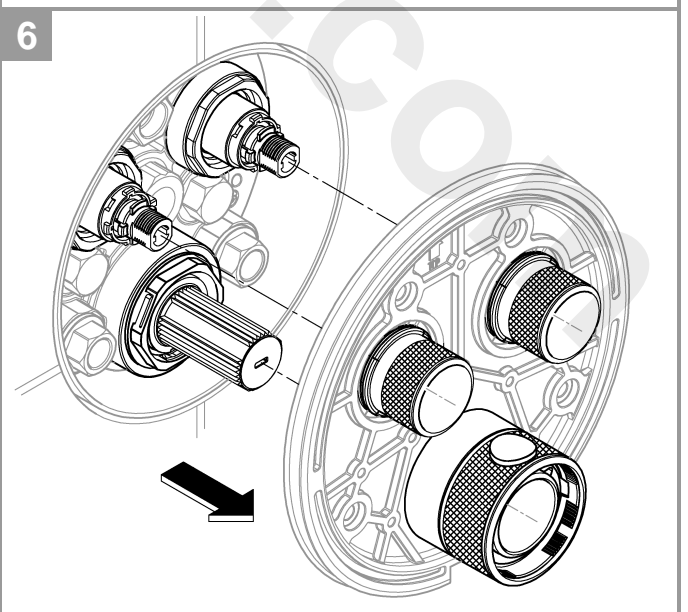
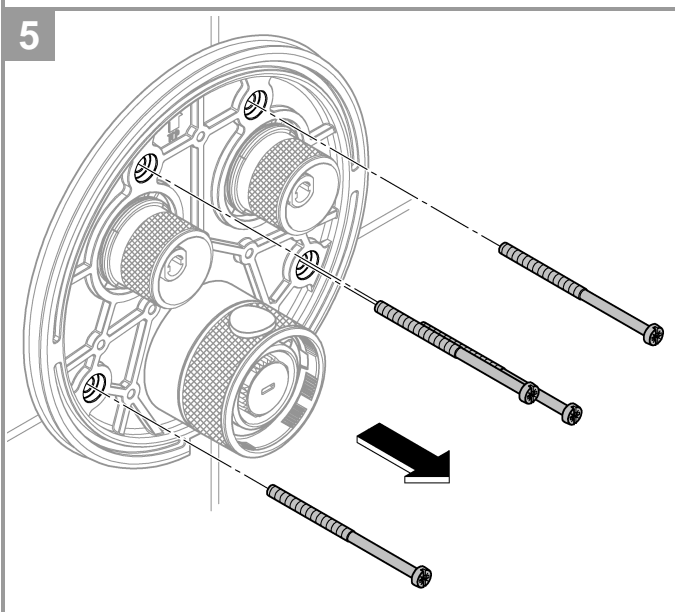
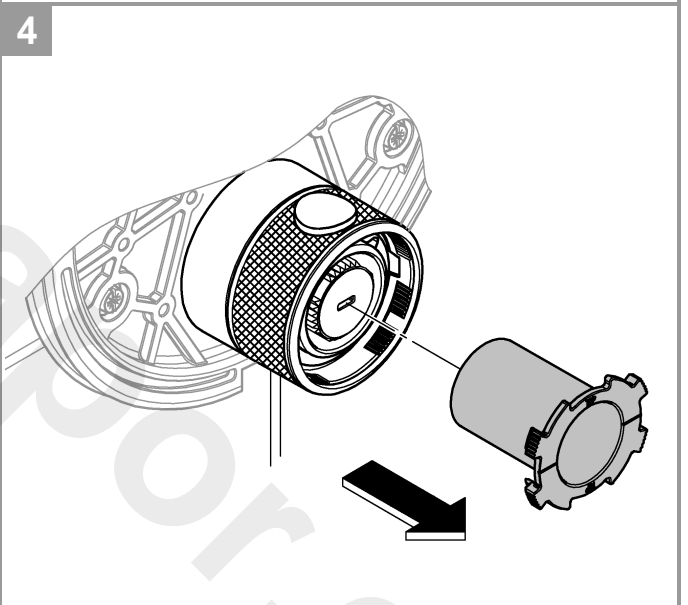
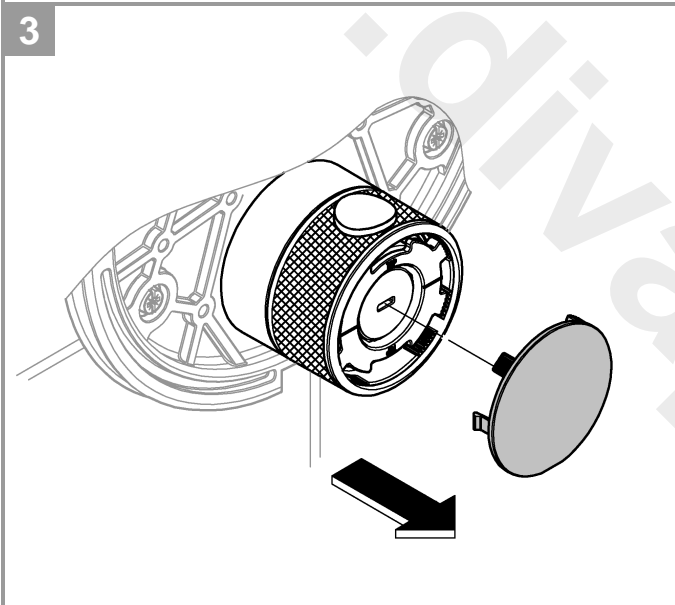
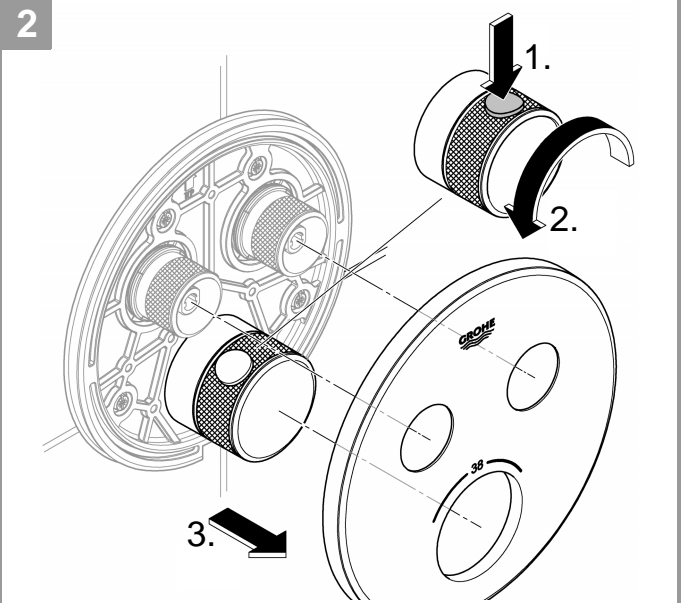
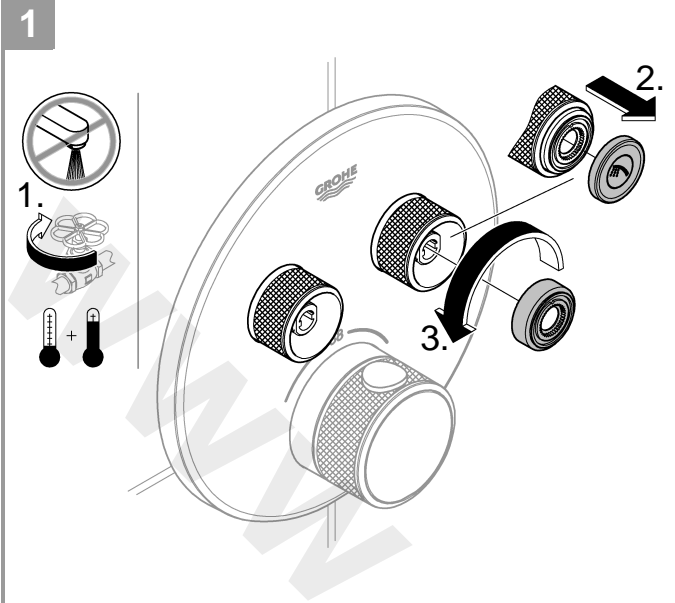
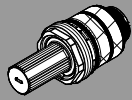

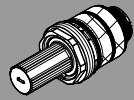

7a

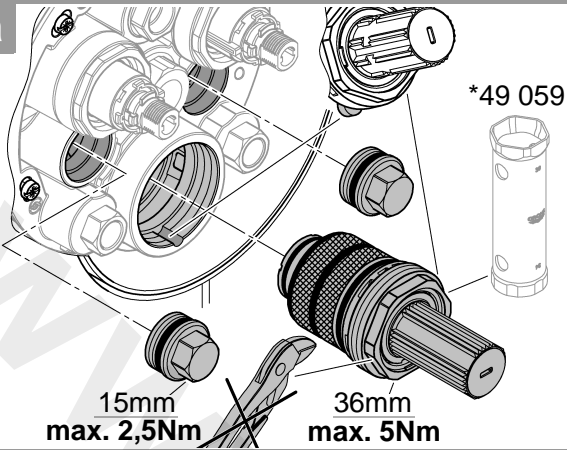

8a

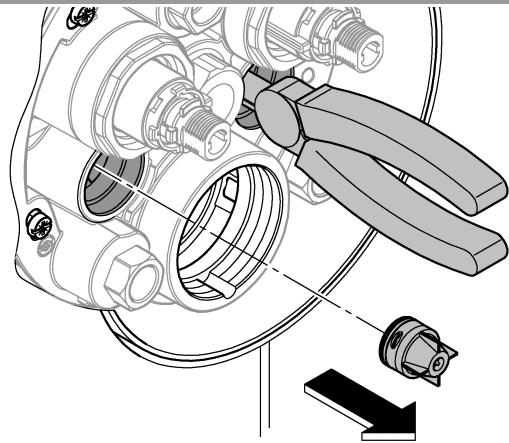

9a

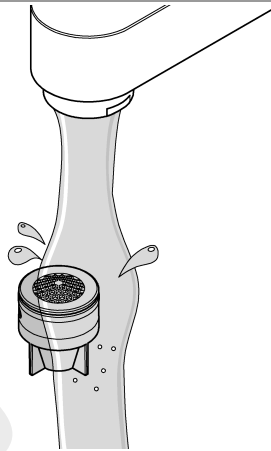
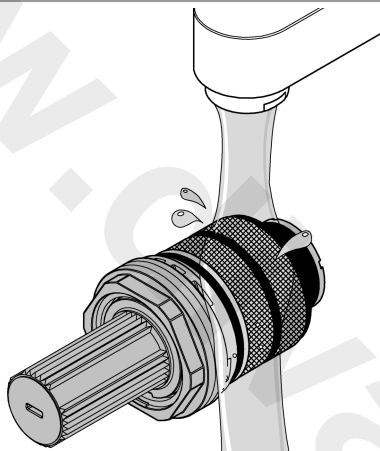

7b

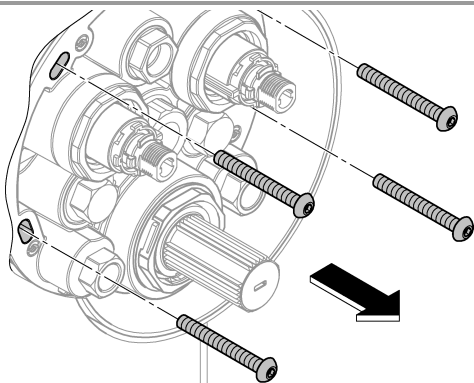

8b

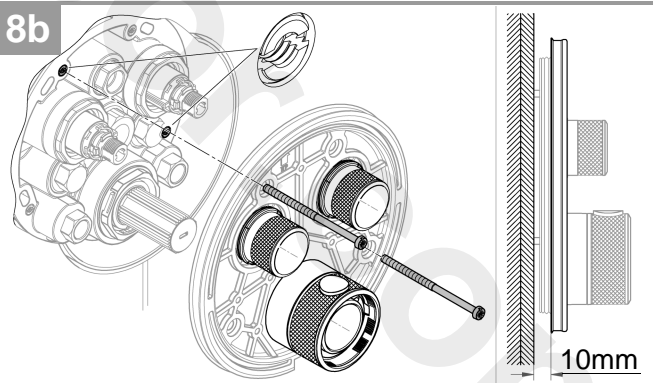

9b

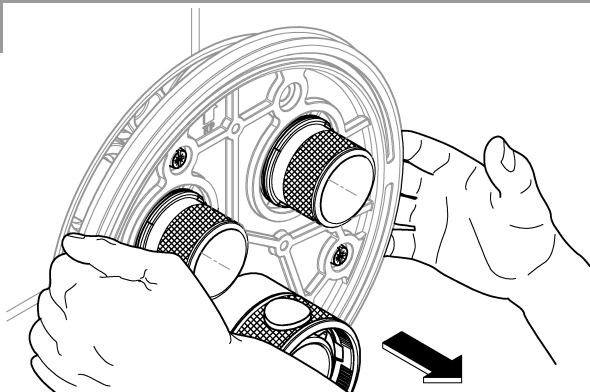

10b

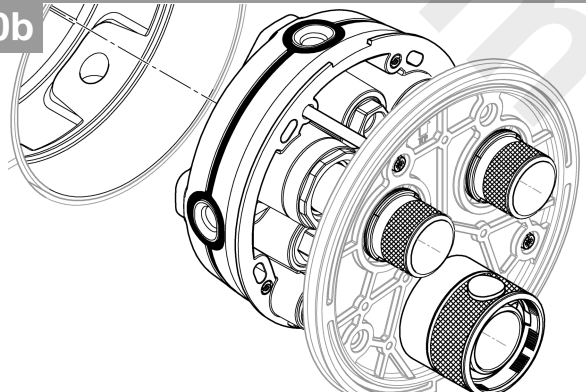

## Safety information



### Avoiding scalding

It is recommended that thermostatic devices able to limit the water temperature to 43 °C be installed at points of discharge with special attention to the outlet temperature (hospitals, schools, nursing and retirement homes). This product is equipped with a temperature end stop. It is generally recommended that the temperature of shower systems not exceed 38 °C in nurseries and specific areas in care homes. Use Grotherm Special thermostats with special handles for facilitating thermal disinfection and with an appropriate safety end stop. Applicable standards (e.g. EN 806-2) and technical regulations for potable water must be observed.

## Technical Data

- Flow pressure
  - Minimum flow pressure without downstream resistances 50 kPa
  - Minimum flow pressure with downstream resistances 100 kPa
  - Dynamic pressure ratio 150:500 kPa
- Minimum flow rate 5 l/min
- Temperature
  - Hot water supply max. 70 °C
  - Recommended for energy saving 60 °C
  - Thermal disinfection possible
  - Safety stop 43 °C
- Hot water temperature at supply connection min. 2 °C higher than mixed water temperature

Flow rates without downstream resistances, see page 1. **These should be observed when dimensioning the outlet!**

### The following special accessories are available:

- Extension 25mm (prod. no.: 14 048)
- An approved safety device is prescribed according to EN 1717 for combining with bath fillers and pop-up overflows (prod. no. 14 055)
- Isolating valves (prod. no.: 14 053)

Thermostat compact cartridge for exchanged water channels: Reversed connections, hot on right and cold on left, replace compact cartridge (prod. no.: 49 003)

## Installation

This product must be installed in conformance with local codes e.g. AS/NZS 3500 series of standard!

- In order to flush, remove the plugs (Y), see page 2 Fig. [4].
- Open cold and hot water supply and check connections for watertightness!
- Alignment of functional unit by 6° possible.
- Measure valves, see page 5 Fig. [18]. For a dimension larger than 18mm, the enclosed extension must be used.

## Adjusting to 38 °C

- Before the mixer is put into service if the mixed water temperature measured at the point of discharge varies from the desired temperature set on the thermostat, see page 6 Fig. [20].
- Every time following maintenance on the thermostatic compact cartridge.

## Temperature limitation

The safety stop limits the temperature range to 38 °C. If a higher temperature is required, the 38 °C stop can be overridden by pressing the button.

## Danger of frost damage

When the domestic water system is drained, the thermostats must be drained separately since non-return valves are installed in the hot and cold water connections.

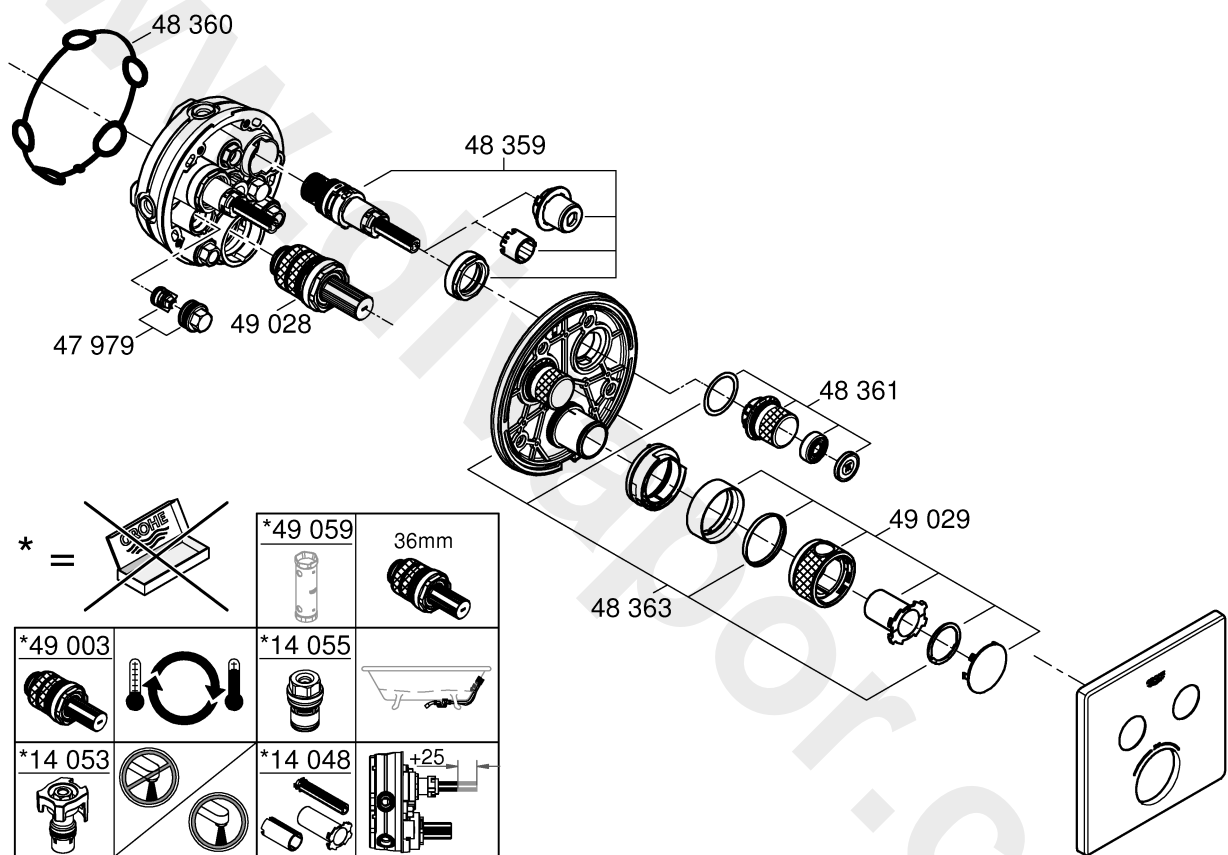





www.divapor.com

**AUS**

Reece Australia Pty Ltd  
118 Burwood Hwy  
Burwood VIC 3125

Tel.: +61 3 9274 0000  
Email: admin@reece.com.au



**NZ**

Robertson  
25 Vestey Drive  
Mt Wellington, Auckland

Tel.: +64 9 5730490  
Email: sales@robertson.co.nz