

AXOR

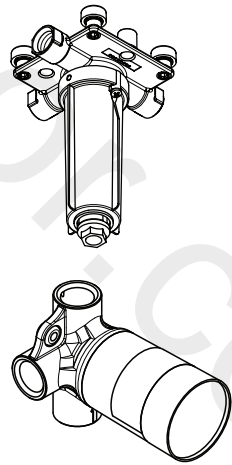

EN Installation / User Instructions / Warranty
FR Instructions de montage / Mode d'emploi / Garantie
ES Instrucciones de montaje / Manejo / Garantía

AXOR
26434181

INSTALLATION

ENGLISH

TECHNICAL INFORMATION

Water pressure	
Recommended	15 - 75 PSI (0.1 - 0.5 MPa)
Maximum	145 PSI (1 MPa)
Hot water temp.	
Recommended	120°-140° F (48° - 60° C)*
Maximum	158°F (70° C)*
Maximum flow rate of showerhead:	
35297xx1, 35312xx1	2.5 GPM (9.5 L/min)
35365xx1, 35319xx1	1.75 GPM (6.6 L/min)
48483xx1	2.5 GPM (9.5 L/min)
48484xx1	1.75 GPM (6.6 L/min)

* Please know and follow all applicable local plumbing codes when setting the temperature on the water heater.

INSTALLATION CONSIDERATIONS

- / For best results, Hansgrohe recommends that this unit be installed by a licensed, professional plumber.
- / Please plan your installation carefully. Read over the installation instructions for all components. Make sure that you have all tools and supplies needed to complete the installation. If you have any questions, please contact Hansgrohe Technical Service before beginning installation.
- / This rough is for use with AXOR ShowerSolutions showerheads 35297xx1, 35312xx1, 35365xx1, 35319xx1, and AXOR One 48483xx1, 48484xx1 (not included)
- / This unit must be installed with the included Trio Green diverter #30371441 or with Quattro Green diverter #15936181 (not included - sold separately).
- / The trim kit for the Trio Green is sold separately.
- / There are no controls on the showerheads. The spray functions are controlled by the diverter.
- / To prevent scald injury, the maximum output temperature of the shower valve must be no higher than 120°F (49° C). In Massachusetts, the maximum output temperature can be no higher than 112°F (44° C).
- / Keep this booklet and the receipt (or other proof of date and place of purchase) for this product in a safe place. The receipt is required should it be necessary to request warranty parts.

DONNÉES TECHNIQUES

Pression d'eau	
recommandée	15 - 75 PSI (0,1 - 0,5 MPa)
maximum	145 PSI (1 MPa)
Température d'eau chaude	
recommandée	120°-140° F (48° - 60° C)*
maximum	158° F (70° C)*
Capacité nominale de la pomme de douche:	
35297xx1, 35312xx1	2.5 GPM (9.5 L/min)
35365xx1, 35319xx1	1.75 GPM (6.6 L/min)
48483xx1	2.5 GPM (9.5 L/min)
48484xx1	1.75 GPM (6.6 L/min)

* Vous devez connaître et respecter tous les codes de plomberie locaux applicables pour le réglage de la température du chauffe-eau.

À PRENDRE EN CONSIDÉRATION POUR L'INSTALLATION

- / Pour de meilleurs résultats, Hansgrohe recommande que ce produit soit installé par un plombier professionnel licencié.
- / L'ensemble de garniture pour le Trio Green est vendu séparément.
- / Préparez-vous bien avant de commencer. Lisez les instructions d'installation de tous les composants. Assurez-vous de disposer de tous les outils et du matériel nécessaires pour l'installation. Si vous avez des questions, veuillez contacter l'assistance technique de Hansgrohe avant de commencer l'installation.
- / Les pommes de douche ne disposent pas de boutons de contrôle. Les modes de jet sont commandés par l'inverseur.
- / Cette pièce intérieure est conçue pour utilisation avec les pommes de douche № de la gamme AXOR ShowerSolutions 35297xx1, 35312xx1, 35365xx1, 35319xx1, № de la gamme AXOR One 48483xx1, 48484xx1 (non compris).
- / Pour empêcher des blessures par ébullition, la température de sortie maximale du robinet de douche ne doit pas excéder 120°F (49°C). Au Massachusetts, la température de sortie maximale du robinet de douche ne doit pas excéder 112°F (44°C).
- / Cette pomme de douche doit être installée avec l'inverseur Trio Green n° 30371441 (inclus) ou avec l'inverseur Quattro Green n° 15936181 (non compris).
- / Conservez ce livret et le reçu (ou une autre preuve sur laquelle figurent la date et l'endroit de l'achat) pour ce produit dans un endroit sûr. Le reçu est requis si vous commandez des pièces sous garantie.

DATOS TECNICOS

Presión en servicio	
recomendada	15 - 75 PSI (0.1 - 0.5 MPa)
max.	145 PSI (1 MPa)
Temperatura del agua caliente	
recomendada	120°-140° F (48° - 60° C)*
max.	158° F (70° C)*
Caudal máximo de la ducha cabezal:	
35297xx1, 35312xx1	2.5 GPM (9.5 L/min)
35365xx1, 35319xx1	1.75 GPM (6.6 L/min)
48483xx1	2.5 GPM (9.5 L/min)
48484xx1	1.75 GPM (6.6 L/min)

* Debe conocer y cumplir todos los códigos locales aplicables para ajustar la temperatura del calentador de agua.

CONSIDERACIONES PARA LA INSTALACIÓN

- / Para obtener mejores resultados, la instalación debe estar a cargo de un plomero profesional matriculado.
- / El juego de pieza exterior para el distribuidor Trio Green se vende por separado.
- / Planifique la instalación cuidadosamente. Repase las instrucciones de instalación para todos los componentes. Asegúrese de tener las herramientas y los insumos necesarios para completar la instalación. Si tiene alguna pregunta, comuníquese con el Servicio técnico de Hansgrohe antes de comenzar la instalación.
- / No hay controles en las duchas cabezales. Las funciones de rociado se controlan mediante el distribuidor.
- / Esta pieza interior se usa con las duchas cabezales de la Colección de AXOR ShowerSolutions 35297xx1, 35312xx1, 35365xx1, 35319xx1, de la Colección de AXOR One 48483xx1, 48484xx1 (no incluida).
- / Para evitar escaldaduras, la máxima temperatura de salida de la válvula de la ducha no debe exceder los 120°F (49° C). En Massachusetts, la máxima temperatura de salida de la válvula de la ducha no debe exceder los 112°F (44°C).
- / Esta ducha debe instalarse con un distribuidor Trio Green #30371441 (incluido) o con un distribuidor Quattro Green #15936181 (no incluido).
- / Mantenga este folleto y el recibo (u otro comprobante del lugar y fecha de compra) de este producto en lugar seguro. El recibo se requiere en caso de ser necesario solicitar piezas bajo garantía.

INSTALLATION SUGGESTIONS / SUGGESTIONS D'INSTALLATION / SUGERENCIAS PARA LA INSTALACIÓN

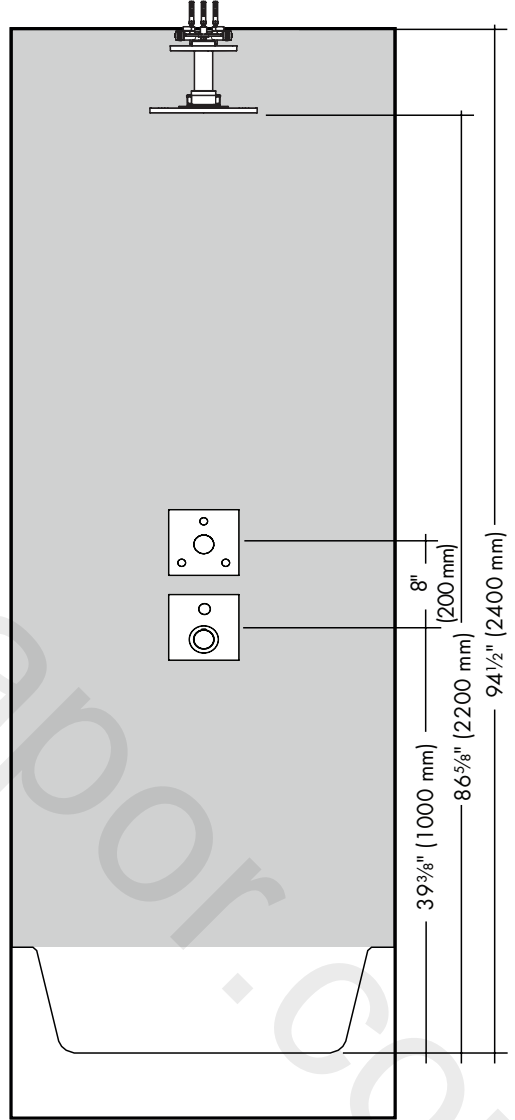
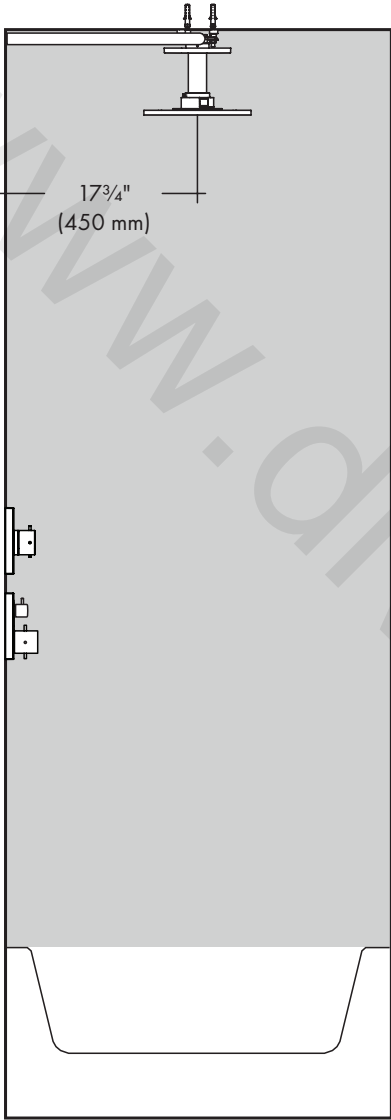

12 mm

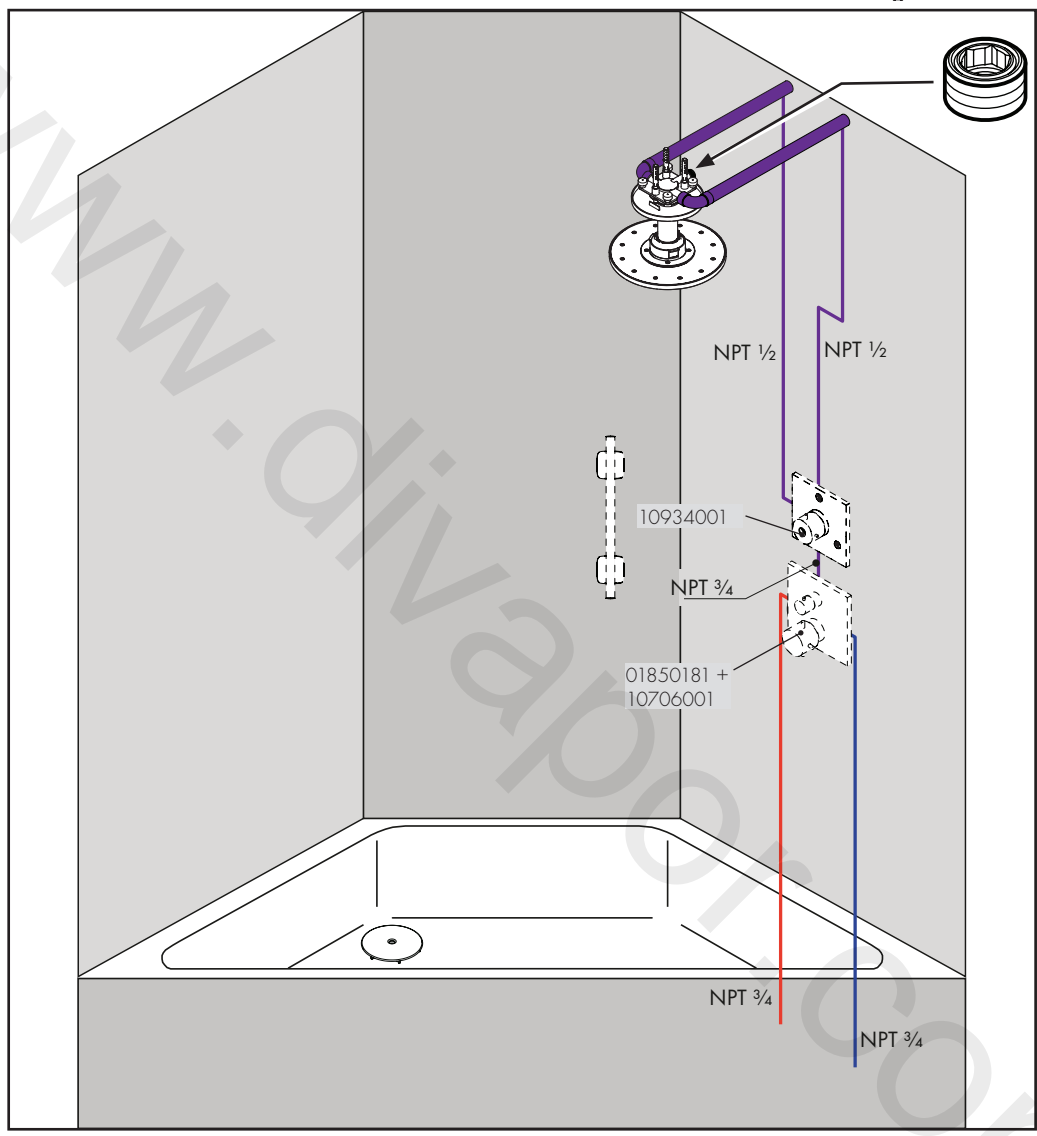

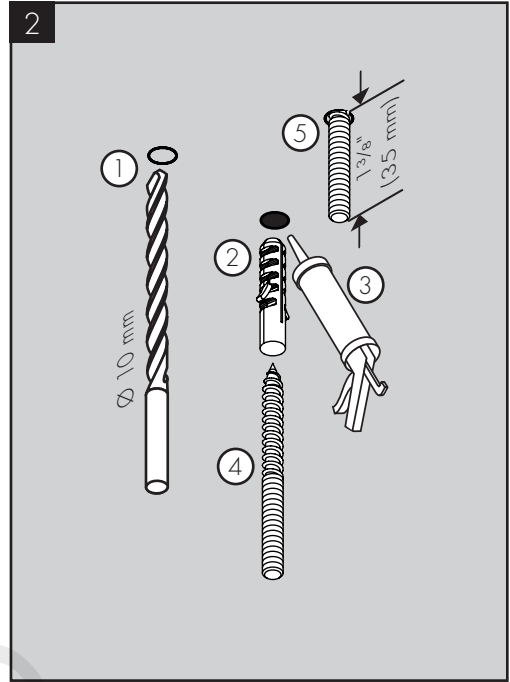
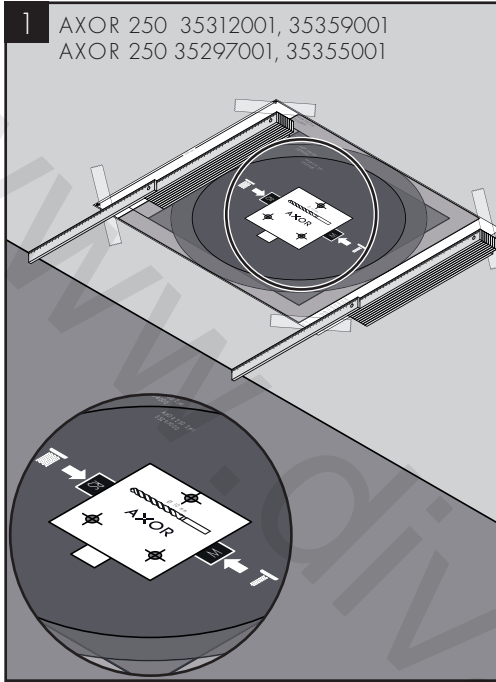

ENGLISH

FRANÇAIS

ESPAÑOL

Position the template for the showerhead on the mounting surface.

Placez le gabarit de la pomme de douche sur la surface de montage.

Coloque la plantilla para el cabezal de ducha sobre la superficie de montaje.

Mark the positions of the screw holes.

Marquez les positions des trous de vissage.

Marque las posiciones de los orificios para tornillos.

Drill the holes using a 10 mm (3/8") bit.

Percez les trous à l'aide d'une mèche de 10 mm.

Perfore los orificios con una broca de 10 mm.

Install the anchors.

Installez les chevilles.

Instale los pernos de anclaje.

Seal the mounting surface around the anchors using waterproof sealant.

Scellez la surface de montage autour des chevilles à l'aide d'un agent d'étanchéité.

Selle la superficie de montaje alrededor de los pernos de anclaje con un sellador impermeable.

Install the studs.

Installez les goujons.

Instale los tornillos espárrago.

3

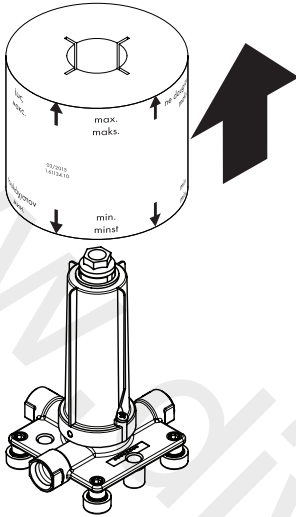

ENGLISH

Remove the distance tube from the rough.

Install the rough on the mounting surface using the washers and nuts.

FRANÇAIS

Retirez le tube d'espacement de la pièce intérieure.

Installez la pièce intérieure sur la surface de montage en utilisant les rondelles et écrous.

4

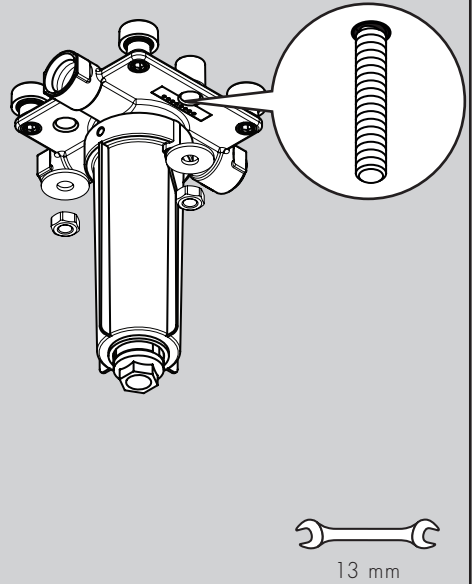

ESPAÑOL

Retire el tubo de distancia de la pieza interior.

Instale la pieza interior en la superficie de montaje usando las arandelas y las tuercas.

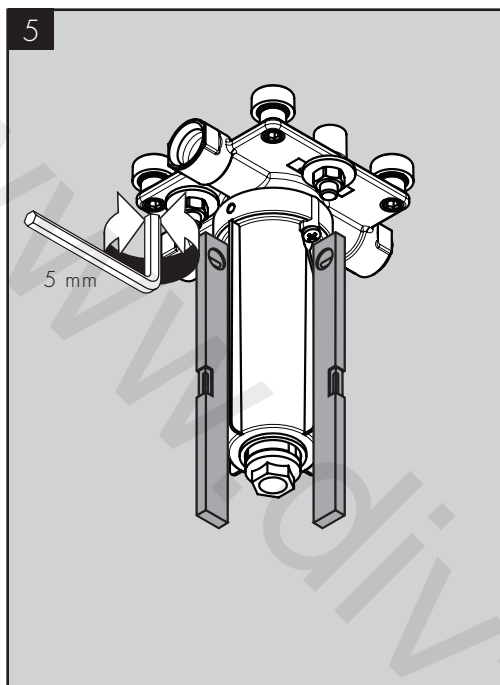

ENGLISH

Make sure that the unit is level.

If necessary, tighten or loosen the spacers using a 5 mm Allen wrench.

Wrap the threads using plumber's thread tape.

Install the inlet lines

Install a plug in the unused port.

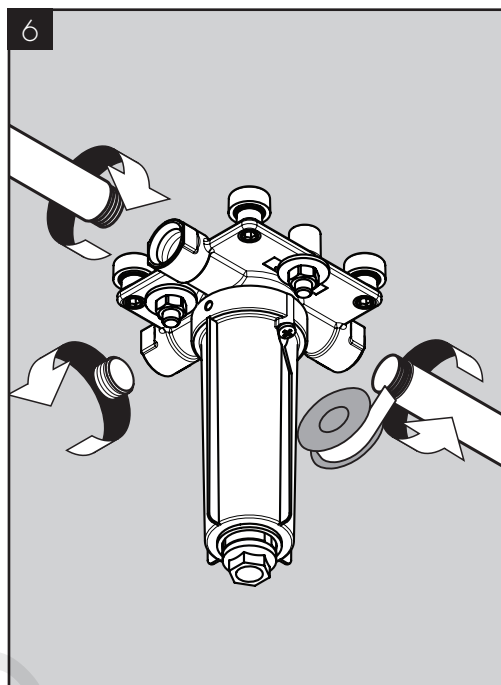

ESPAÑOL

Asegúrese de que la unidad quede nivelada.

De ser necesario, ajuste o afloje los separadores con una llave Allen de 5 mm.

Envuelva las roscas con cinta de plomero para roscas.

Instale la(s) línea(s) de entrada.

Tape el orificio sin usar.

FRANÇAIS

Assurez-vous que le produit est de niveau.

Si nécessaire, serrez ou desserrez les pièces d'espacement à l'aide d'une clé hexagonale de 5 mm.

Enroulez les filets de à l'aide de ruban de plomberie.

Installez la ou les conduite(s) d'entrée.

Bouchez l'orifice non utilisé.

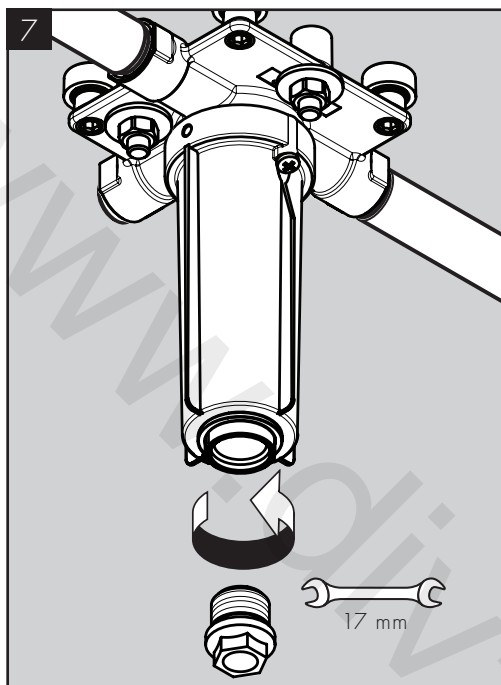

ENGLISH

Remove the outlet plug.

Loosen the screw that holds the plastic pipe in place.

FRANÇAIS

Retirez le bouchon.

Desserrez la vis qui maintient le tuyau en plastique en place.

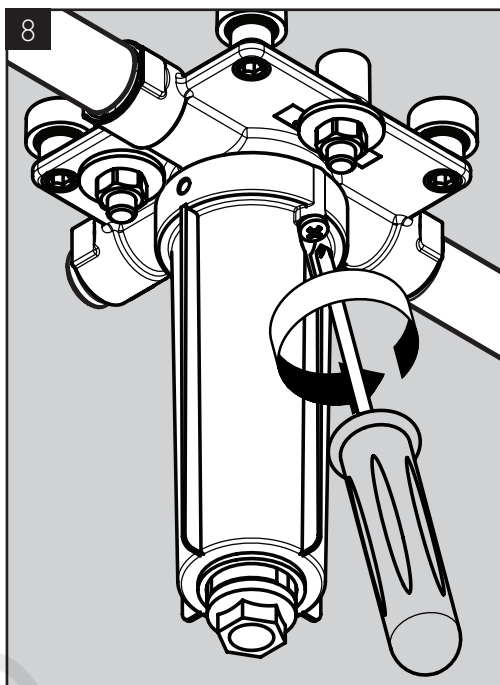

ESPAÑOL

Retire el tapón.

Aloje el tornillo que sostiene el caño de plástico en su lugar.

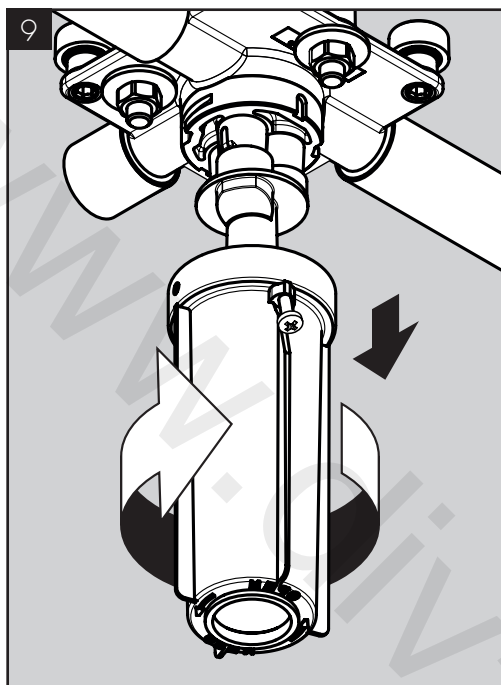

ENGLISH

Remove the plastic pipe.

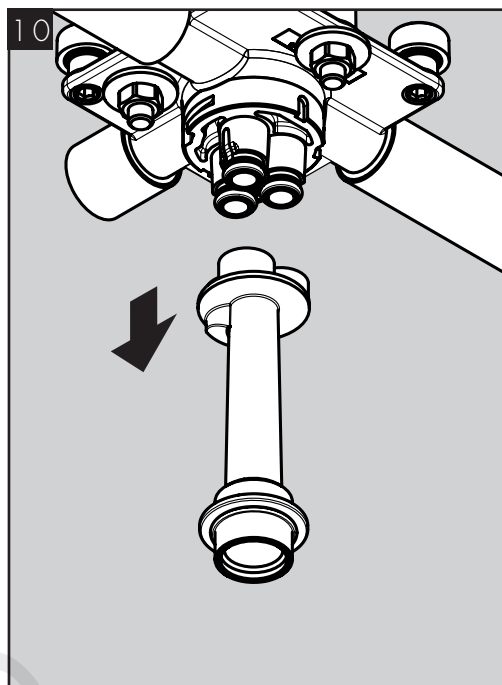

FRANÇAIS

Retirez le tuyau en plastique.

ESPAÑOL

Retire el caño de plástico.

Remove the water guide.

Retirez le conduit d'eau.

Retire la guía de agua.

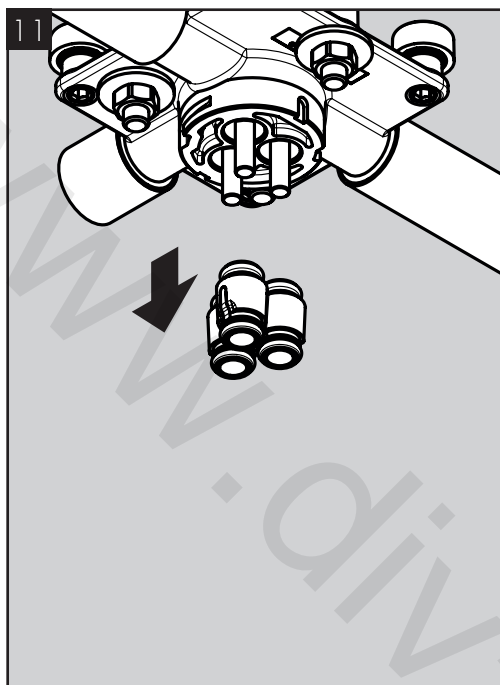

ENGLISH

Remove the water guide spacer.

Remove the plugs.

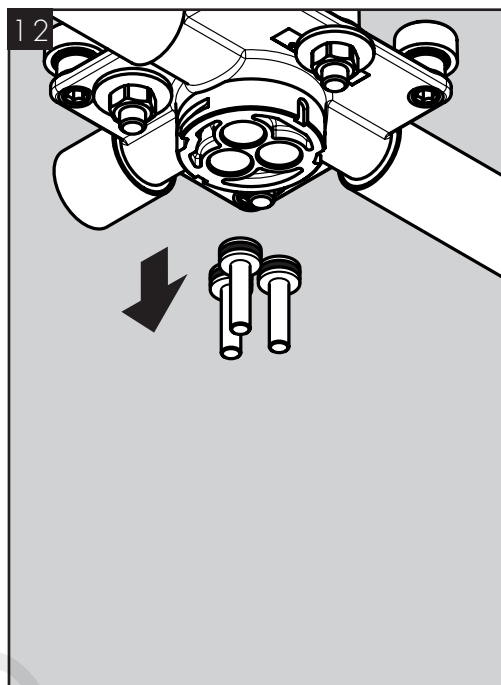

ESPAÑOL

Retire el separador de la guía de agua.

Retire los tapones.

FRANÇAIS

Retirez la pièce d'espacement du conduit d'eau.

Retirez les bouchons.

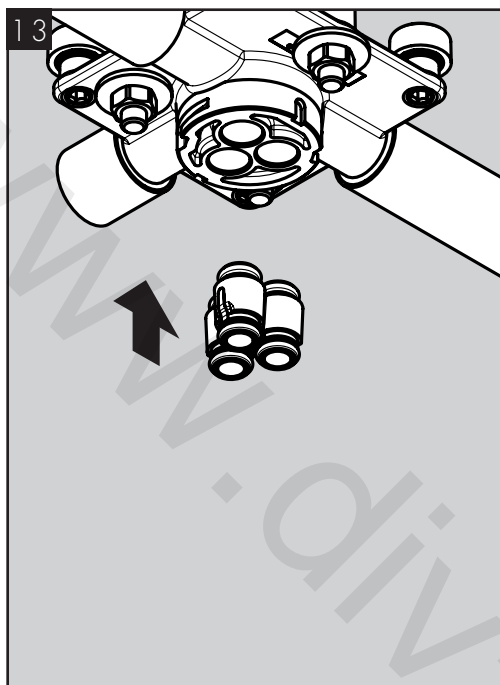

ENGLISH

Reinstall the water guide spacer.

Reinstall the water guide.

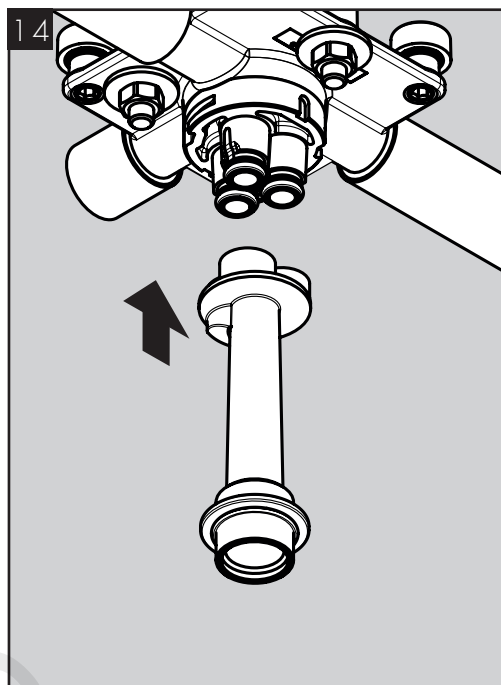

ESPAÑOL

Vuelva a instalar el separador de la guía de agua.

Vuelva a instalar la guía de agua.

FRANÇAIS

Réinstallez la pièce d'espacement du conduit d'eau.

Réinstallez le conduit d'eau.

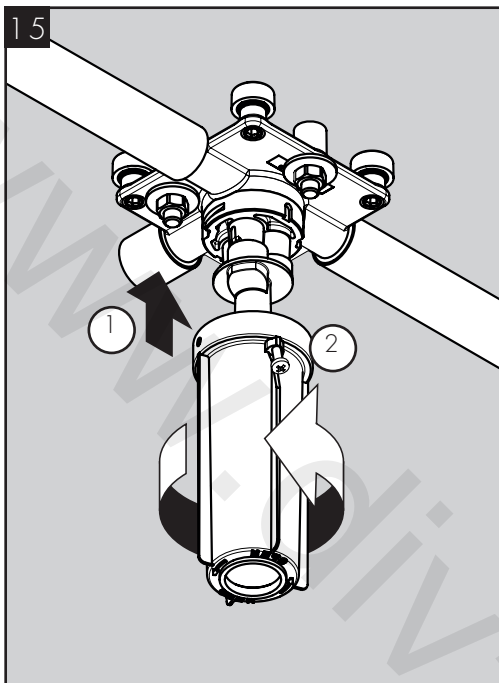

ENGLISH

Reinstall the plastic pipe.

Flush the unit for at least 5 minutes.

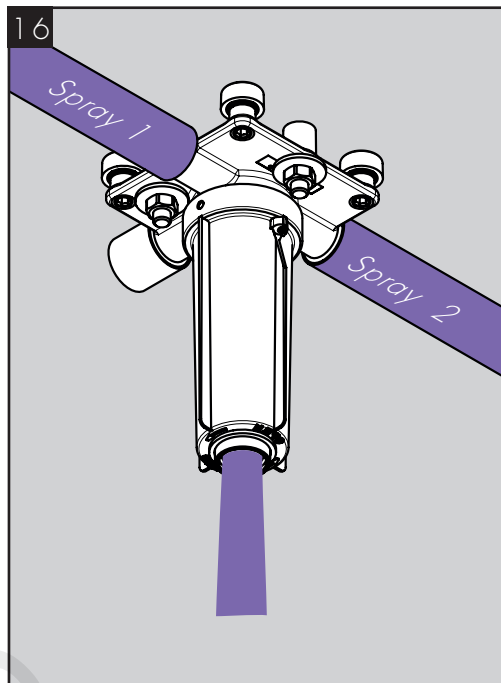

ESPAÑOL

Vuelva a instalar el caño de plástico.

Purgue la unidad durante al menos 5 minutos.

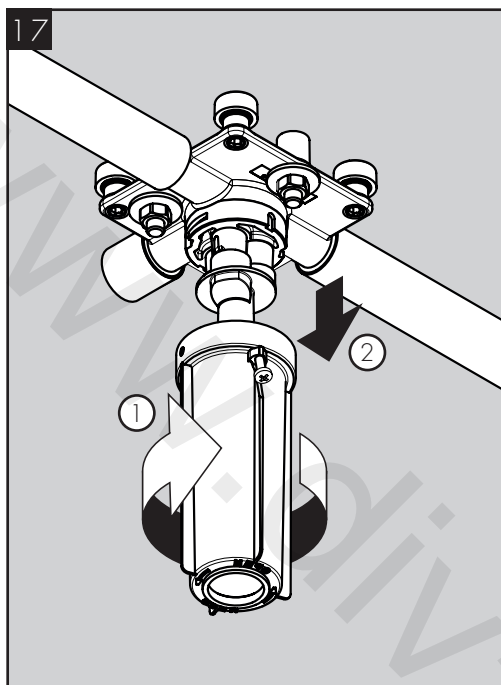

ENGLISH

Remove the plastic pipe.

Remove the water guide.

Remove the water guide spacer.

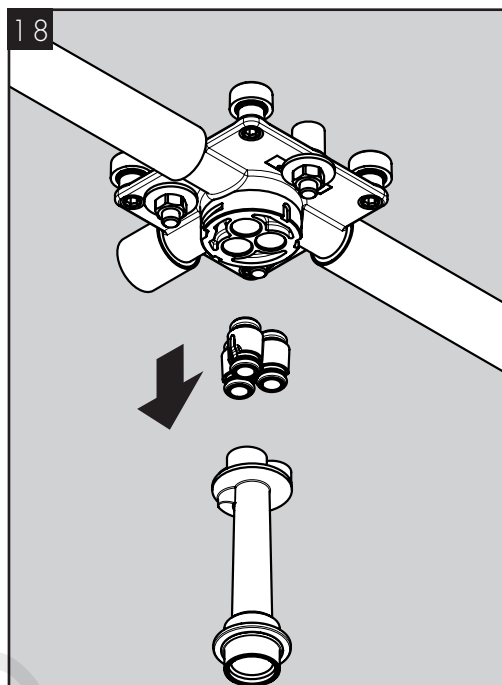

FRANÇAIS

Retirez le tuyau en plastique.

Retirez le conduit d'eau.

Retirez la pièce d'espacement du conduit d'eau.

ESPAÑOL

Retire el caño de plástico.

Retire la guía de agua.

Retire el separador de la guía de agua.

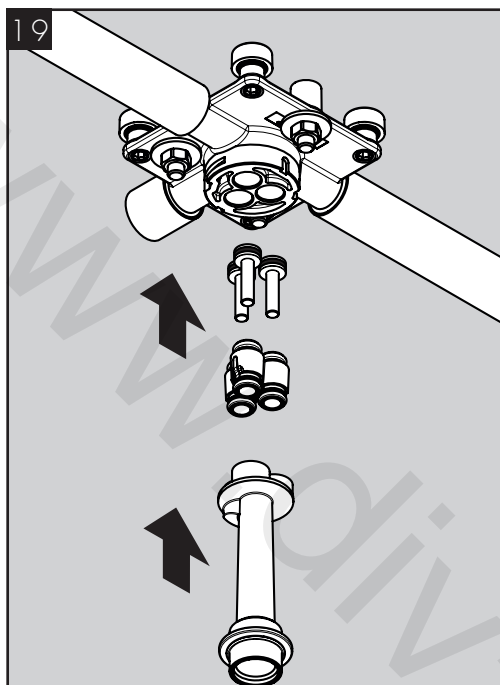

ENGLISH

Reinstall the plugs and the water guide spacer.

Reinstall the water guide.

Reinstall the plastic pipe.

FRANÇAIS

Réinstallez les bouchons et la pièce d'espacement du conduit d'eau.

Réinstallez le conduit d'eau.

Réinstallez le tuyau en plastique.

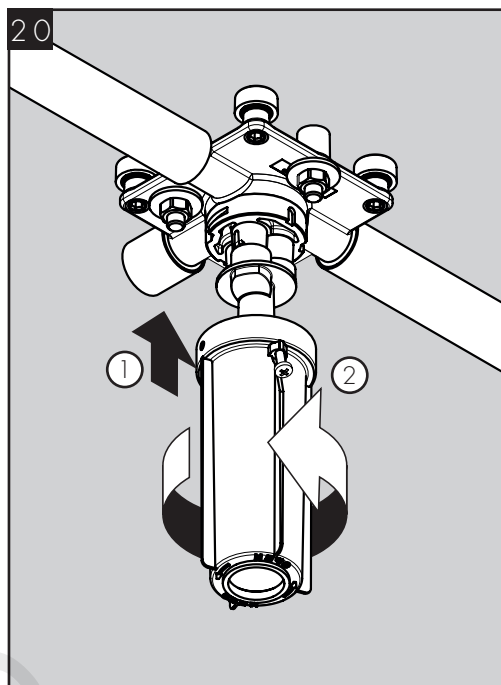

ESPAÑOL

Vuelva a instalar los tapones y el separador de la guía de agua.

Vuelva a instalar la guía de agua.

Vuelva a instalar el caño de plástico.

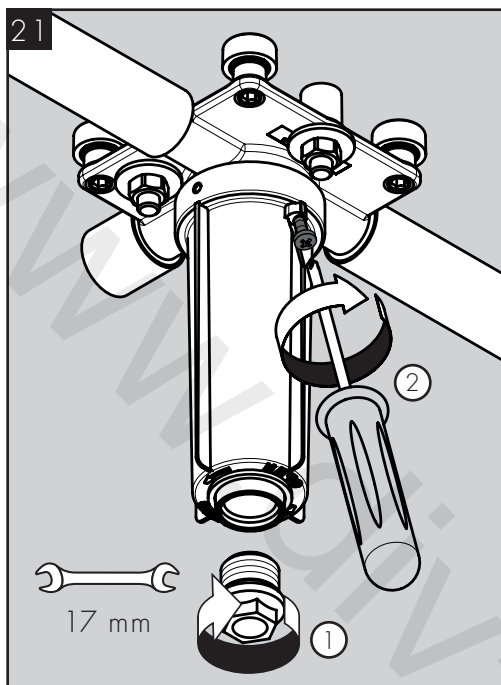

ENGLISH

Reinstall the outlet plug.

Tighten the screw.

Reinstall the distance tube.

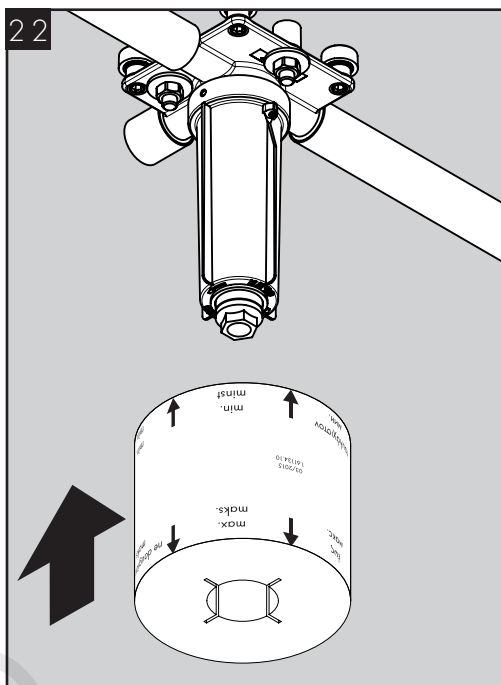

FRANÇAIS

Réinstallez le bouchon.

Serrez les vis.

Réinstallez le tube d'espacement.
Serrez la vis.

ESPAÑOL

Vuelva a instalar el tapón.

Ajuste los tornillos.

Vuelva a instalar el tubo de
distancia. Ajuste el tornillo.

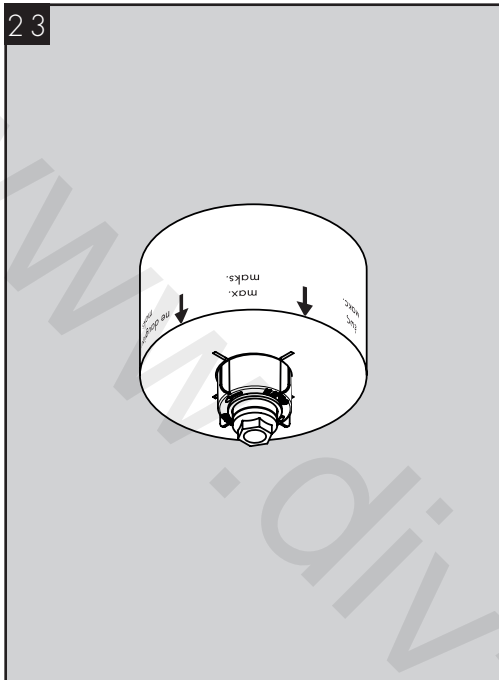

ENGLISH

Install the finished ceiling around the distance tube.

The outside surface of the finished ceiling must fall between the "min" and "max" markings on the distance tube.

FRANÇAIS

Installez le plafond fini autour du tube d'espacement.

La surface extérieure du plafond fini doit se situer entre les marques « min » et « max » figurant sur le tube d'espacement.

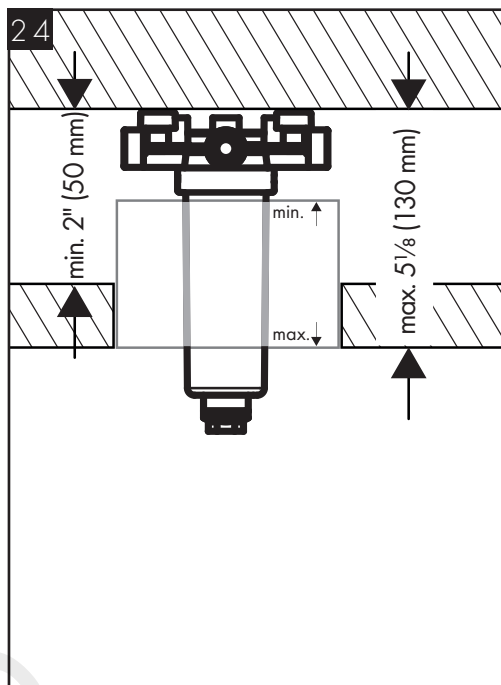

ESPAÑOL

Instale el cielo raso terminado cerca del tubo de distancia.

La superficie externa del cielo raso terminado debe quedar entre las marcas de máximo y mínimo del tubo de distancia.

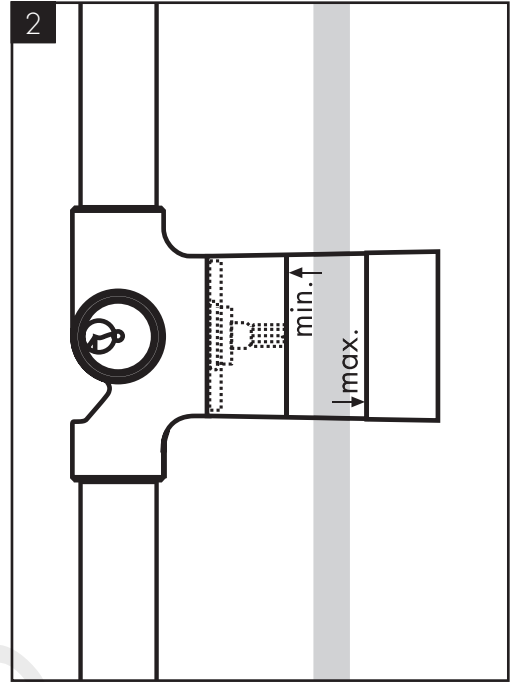
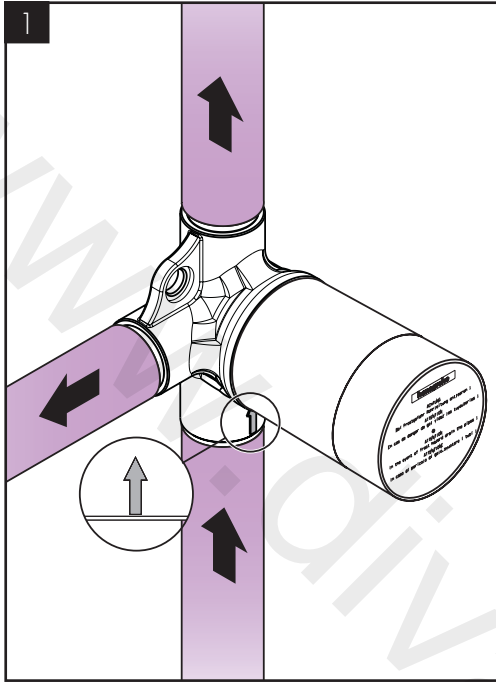

ENGLISH

FRANÇAIS

ESPAÑOL

An arrow showing the direction of the water flow is cast into the valve body.

Une flèche indiquant la direction du débit figure sur le corps de la valve.

En el cuerpo de la válvula está fundida una flecha que muestra el sentido del flujo de agua.

⚠ The water must flow through the valve in that direction or damage to the cartridge will occur.

⚠ Si l'eau ne coule pas dans la valve dans cette direction, la cartouche sera endommagée.

⚠ El agua debe circular por la válvula en ese sentido, puesto que de lo contrario puede dañarse el cartucho.

Install the valve so that the outside surface of the finished wall falls between the "minimum" and "maximum" lines marked on the plaster shield.

Installez la valve de façon à ce que la surface extérieure du mur fini tombe entre les lignes « minimum » et « maximum » figurant sur le protecteur de plâtre.

Instale la válvula de modo que la superficie exterior de la pared terminada quede entre las líneas "min" y "max" marcadas en el protector de yeso.

⚠ Do not remove the plaster shield from the valve.

⚠ Ne retirez pas le protecteur de plâtre de la valve.

⚠ No retire el protector de yeso de la válvula.

3

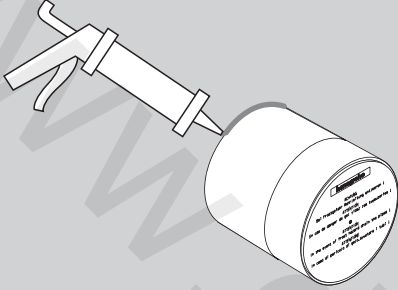

ENGLISH

Install the sheet rock or green board.

Seal the wall between the sheet rock or green board and the rough valve using waterproof sealant.

Spread adhesive on the wall around the rough.

⚠ Do not use hot glue.

4

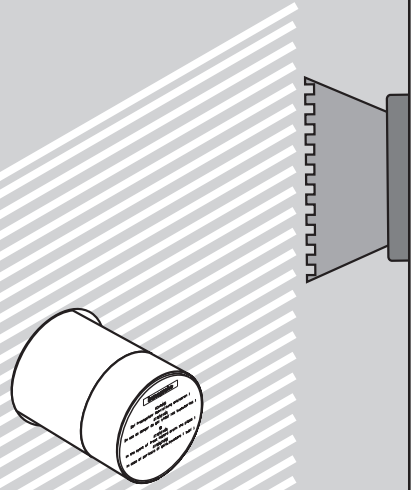

FRANÇAIS

Installez le panneau de plâtre.

Scellez l'espace entre le panneau de plâtre et le boîtier d'installation en utilisant un agent d'étanchéité.

Appliquez un adhésif sur le mur et le boîtier.

⚠ N'utilisez pas de colle chaude.

ESPAÑOL

Instale la placa de yeso.

Selle el espacio entre la placa de yeso y la caja de instalación con un sellador impermeable.

Aplique adhesivo a la pared y a la caja.

⚠ No use cola caliente.

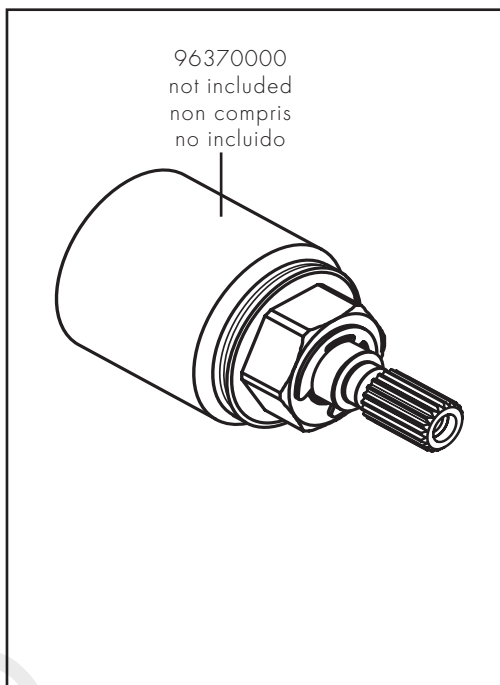
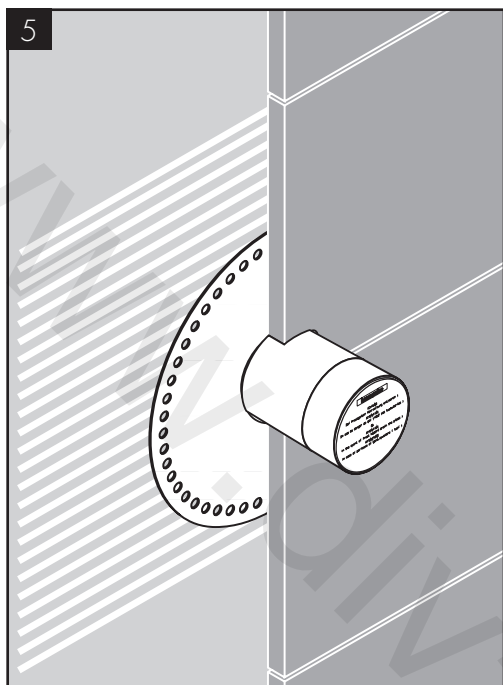

ENGLISH

Install the gasket.

Install the tile or other finished wall surface over the gasket and against the rough.

If the outside surface of the finished wall extends beyond the "maximum" marking on the plaster shield, order extension 96370000 through your Hansgrohe dealer for the Trio Green diverter.

FRANÇAIS

Installez le collet d'étanchéité.

Installez la surface de mur fini sur le collet d'étanchéité et contre le boîtier d'installation.

Si la surface extérieure du mur fini va au-delà de la marque « maximum » du protecteur de plâtre, commandez une rallonge 96370000 auprès de votre détaillant Hansgrohe.

ESPAÑOL

Instale el collar de sellado.

Instale la superficie de la pared terminada sobre el collar de sellado y contra la caja de instalación.

Si la superficie exterior de la pared terminada se extiende más allá de la marca de "máximo" del protector de yeso, solicite la extensión 96370000 al concesionario de Hansgrohe.

REPLACEMENT PARTS / PIÈCES DÉTACHÉES / REPUESTOS

AXOR
26434181

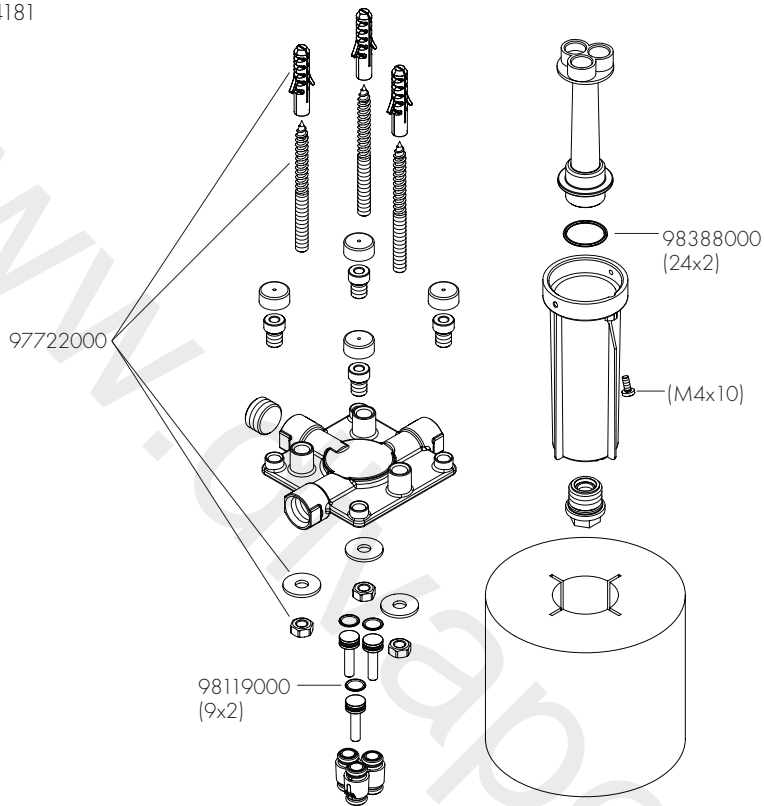

Trio Green
30371441

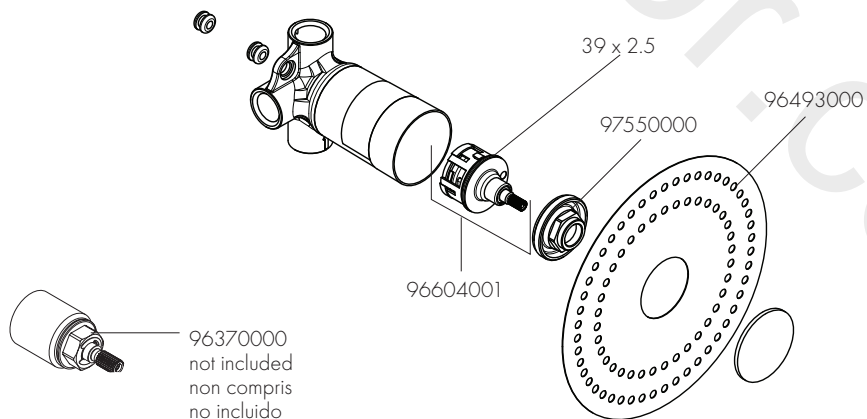

HANSGROHE, INC. LIMITED WARRANTY

Offering our customers the highest quality at all times is a fundamental part of the Hansgrohe, Inc. company philosophy. We offer consumers a limited warranty on our hansgrohe® and AXOR® branded products.

This warranty is limited to products manufactured by Hansgrohe, Inc. that are purchased from a Hansgrohe, Inc. authorized seller by a consumer in the United States or Canada after September 1, 2019, and installed in either the United States or in Canada.

WARRANTY

Hansgrohe, Inc. warrants to the original consumer purchaser that hansgrohe and AXOR products will be free from defects in material and workmanship for as long as the original consumer purchaser owns both the product and the home in which the product was originally installed. For commercial purchasers, the warranty period is (a) one (1) year for hansgrohe products and (b) five (5) years for AXOR products, in each case from the date of purchase. The warranty period for products in the Rubbed Bronze, Matte Black and Matte White finishes are three (3) years from the date of purchase. This warranty is non-transferable.

WHAT WE WILL DO

Hansgrohe, Inc., at its option, will replace any product or part of the product that proves defective in workmanship and/or material, under normal installation, use, service and maintenance. If Hansgrohe, Inc. is unable to provide a replacement part or product and repair is not practical or cannot be made in timely fashion, Hansgrohe, Inc. may elect to refund the purchase price in exchange for the return of the defective product. REPAIR OR REPLACEMENT (OR, IN LIMITED CIRCUMSTANCES, REFUND OF THE PURCHASE PRICE) AS PROVIDED UNDER THIS LIMITED WARRANTY IS THE EXCLUSIVE REMEDY OF THE PURCHASER.

WHAT IS NOT COVERED BY THE WARRANTY

Because Hansgrohe, Inc. is unable to control the quality of hansgrohe or AXOR products sold by unauthorized sellers, unless otherwise prohibited by law, this warranty does not cover hansgrohe or AXOR products purchased from unauthorized sellers. Authorized sellers can be found on hansgrohe and AXOR branded websites.

Labor and other expenses for disconnection, deinstallation, or return of the product for warranty service (including but not limited to proper packaging and shipping costs), or for installation or reinstallation of the product are not covered by this warranty.

Hansgrohe, Inc. shall not be liable for any damage to the product resulting from

- reasonable wear and tear
- outdoor use
- misuse (including use of the product for an unintended application)
- freezing water
- excessive water pressure
- pipe corrosion in the home in which the product is installed
- abuse, neglect or improper or incorrectly performed installation, maintenance or repair, including the use of abrasive or caustic cleaning agents or "no-rinse" cleaning products.

This warranty does not cover: (i) accessories, connected materials and products, or related products not manufactured by Hansgrohe, Inc. (ii) any hansgrohe or AXOR product sold for display purposes or (iii) hansgrohe or AXOR products purchased from unauthorized sellers.

WHAT YOU MUST DO TO OBTAIN WARRANTY SERVICE OR INFORMATION

Contact your retailer, or contact Technical Service at:

Hansgrohe, Inc.
1492 Bluegrass Lakes Parkway
Alpharetta, GA 30004
Toll-free 800-334-0455

In requesting warranty service, you will need to provide:

1. The sales receipt or other evidence of the date and place of purchase.
2. A description of the problem.
3. Delivery of the product or the defective part, postage prepaid and carefully packed and insured, to:

Hansgrohe, Inc.
1492 Bluegrass Lakes Parkway
Alpharetta, GA 30004
Toll-free 800-334-0455

When warranty service is completed, any repaired or replacement product or part will be returned to you postage prepaid.

REVISED SEPTEMBER 1, 2019.

LIMITATION ON DURATION OF IMPLIED WARRANTIES: Some States do not allow limitations on how long an implied warranty lasts, so the below limitations may not apply to you. TO THE MAXIMUM EXTENT PERMITTED BY APPLICABLE LAW, ANY IMPLIED WARRANTY, INCLUDING THE IMPLIED WARRANTIES OF MERCHANTABILITY AND OF FITNESS FOR A PARTICULAR PURPOSE, IS LIMITED TO THE STATUTORY PERIOD OR THE DURATION OF THIS WARRANTY, WHICHEVER IS SHORTER.

LIMITATION OF SPECIAL, INCIDENTAL OR CONSEQUENTIAL DAMAGES: Some States do not allow the exclusion or limitation of incidental or consequential damages, so the below limitations and exclusions may not apply to you. TO THE MAXIMUM EXTENT PERMITTED BY APPLICABLE LAW, THIS WARRANTY DOES NOT COVER, AND HANSGROHE, INC. SHALL NOT BE LIABLE FOR, ANY SPECIAL, INCIDENTAL OR CONSEQUENTIAL DAMAGES (INCLUDING LABOR CHARGES TO REPAIR, REPLACE, INSTALL OR REMOVE THIS PRODUCT), WHETHER ARISING OUT OF BREACH OF ANY EXPRESS OR IMPLIED WARRANTY, BREACH OF CONTRACT, TORT, OR OTHERWISE. HANSGROHE, INC. SHALL NOT BE LIABLE FOR ANY DAMAGE TO THE PRODUCT RESULTING FROM REASONABLE WEAR AND TEAR, OUTDOOR USE, MISUSE (INCLUDING USE OF THE PRODUCT FOR AN UNINTENDED APPLICATION), FREEZING WATER, EXCESSIVE WATER PRESSURE, PIPE CORROSION IN THE HOME IN WHICH THE PRODUCT IS INSTALLED, ABUSE, NEGLECT OR IMPROPER OR INCORRECTLY PERFORMED INSTALLATION, MAINTENANCE

OR REPAIR, INCLUDING THE USE OF ABRASIVE OR CAUSTIC CLEANING AGENTS OR "NO-RINSE" CLEANING PRODUCTS.

NOTICE TO RESIDENTS OF THE STATE OF NEW JERSEY:

The provisions of this warranty, including its limitations, are intended to apply to the fullest extent permitted by the laws of the State of New Jersey.

This warranty gives you specific legal rights, and you may also have other rights which vary from state to state.

PRODUCT INSTRUCTIONS AND QUESTIONS

Upon purchase or prior to installation, please carefully inspect your product for any damage or visible defect. Prior to installing, always carefully study the enclosed instructions on the proper installation and the care and maintenance of this product.

If you have questions at any time about the use, installation or performance of your product, or the Limited Warranty, please write us or call us toll-free at 800-334-0455.

www.divapor.com

www.divapor.com

AXOR

www.divapor.com

AXOR / Hansgrohe, Inc.
1490 Bluegrass Lakes Parkway
Alpharetta, GA 30004
Tel. 800-334-0455
Fax 770-889-1783

axor-design.com