

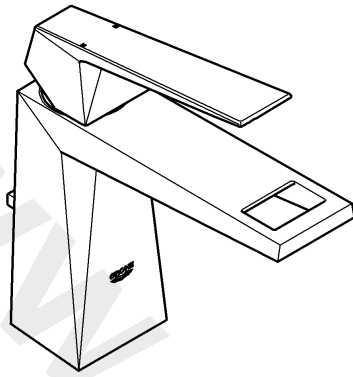

23 034

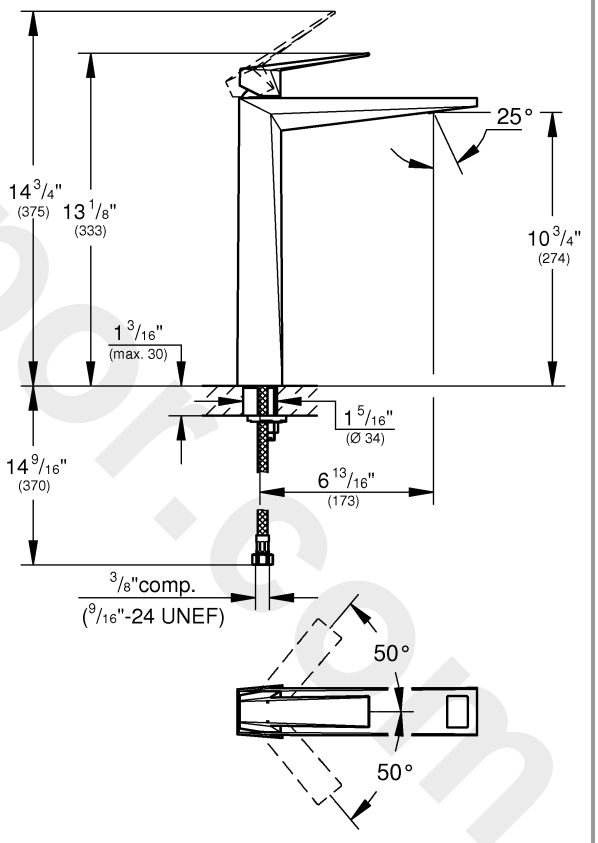

23 115

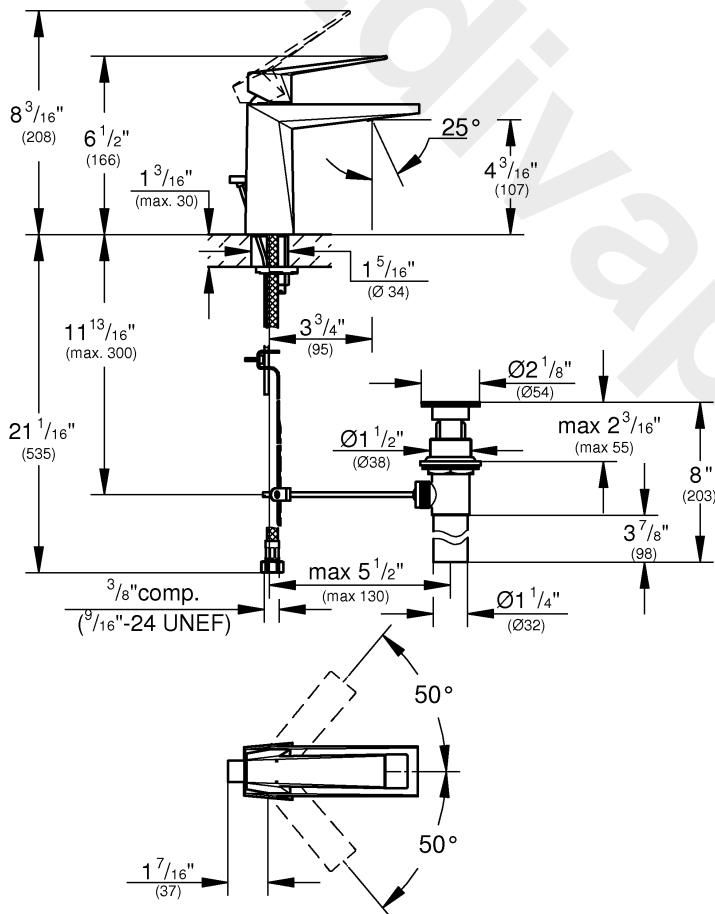
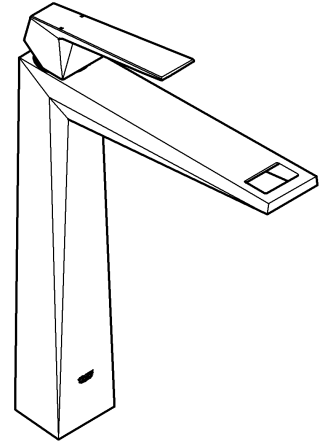

1



2 - 3

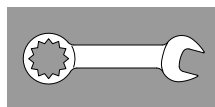

4

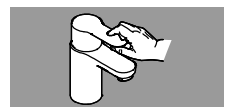

5



6



7





23 034

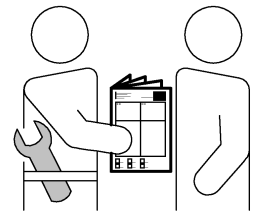
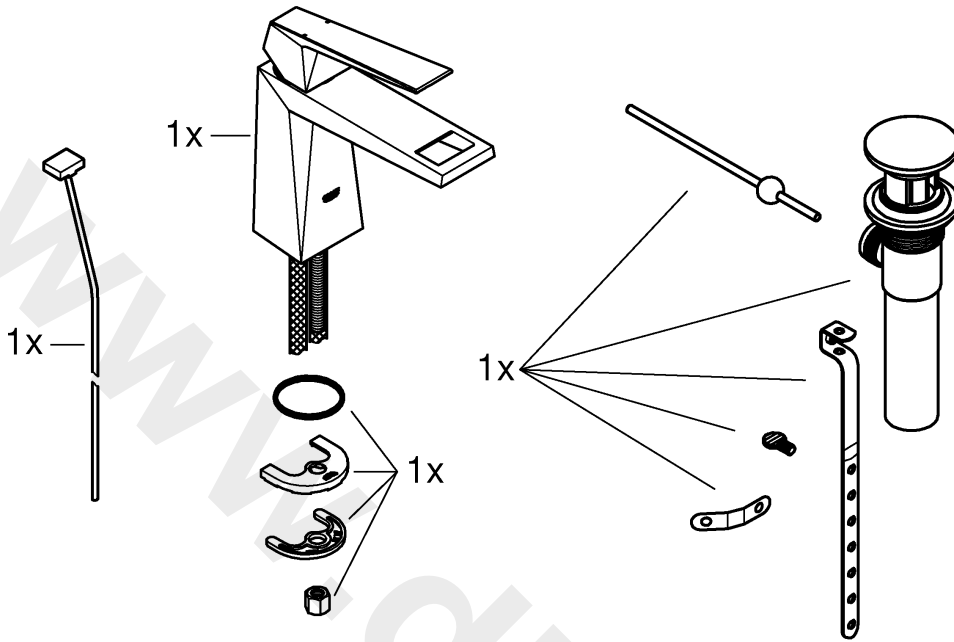

23 115

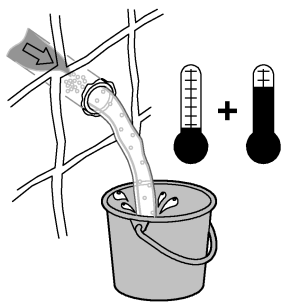
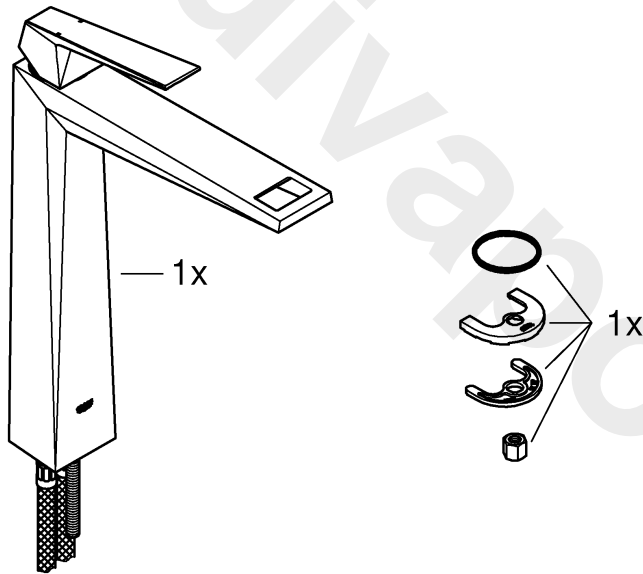

psi

max. 7.25 145 72.5 14.5

bar

max. 0,5 10 5 1

°F

max. 158° 140°

°C

max. 70° 60°

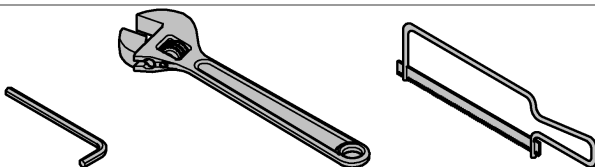

13mm
*19 017



1

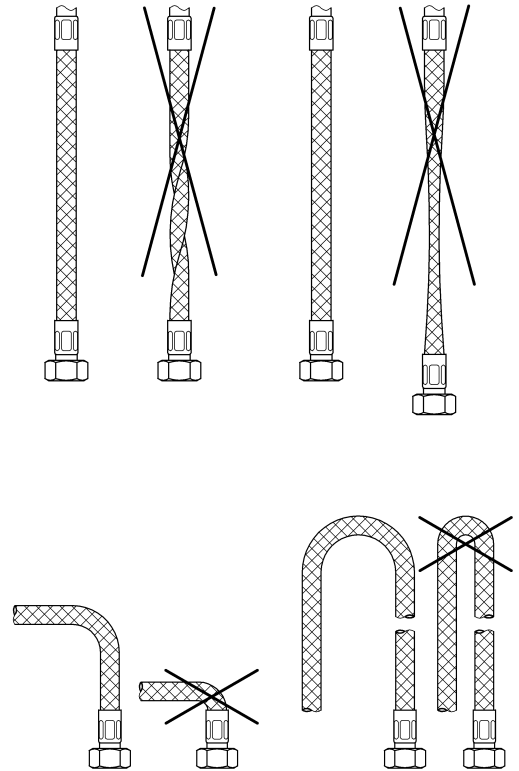
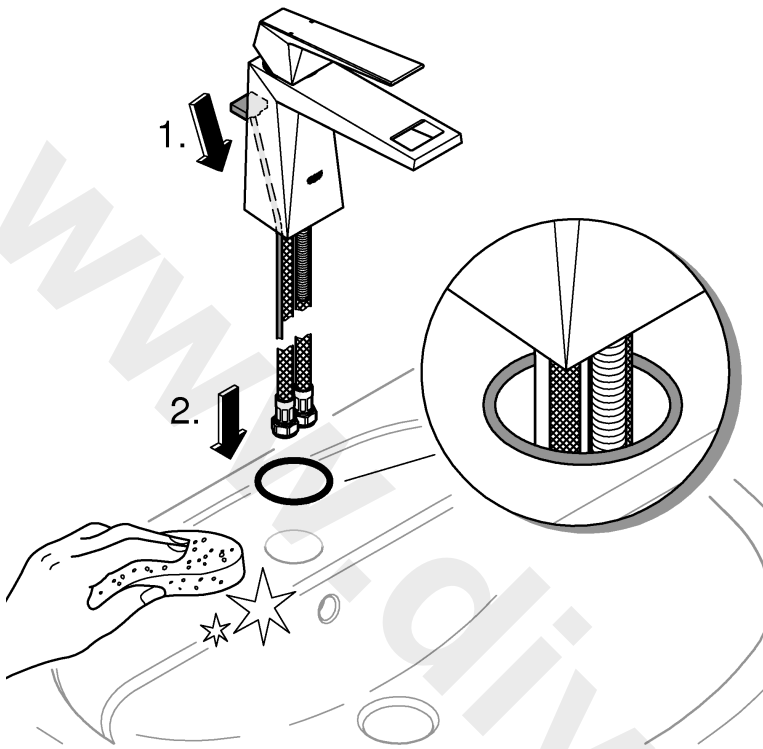

2

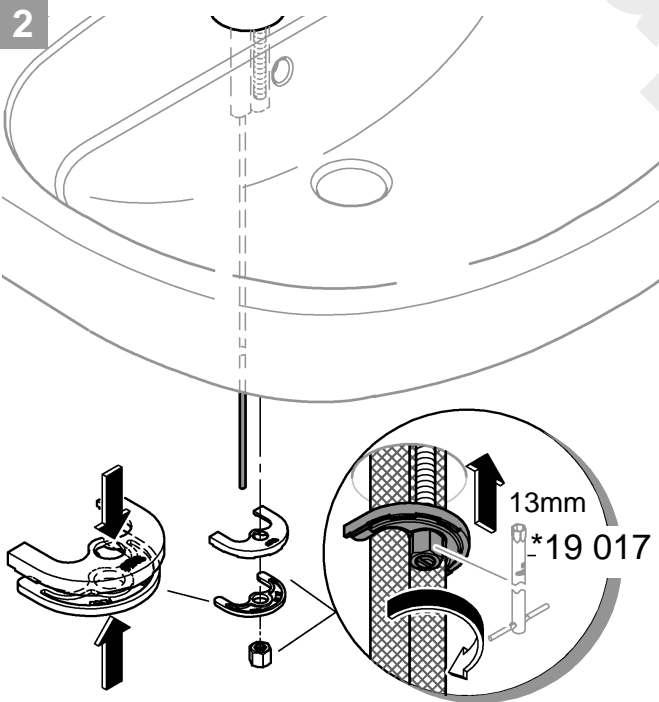

3

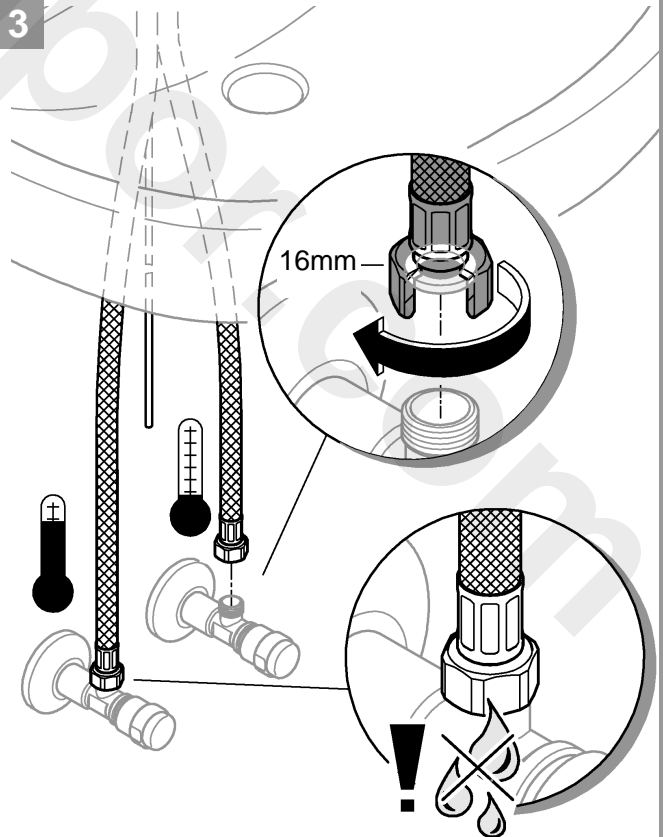

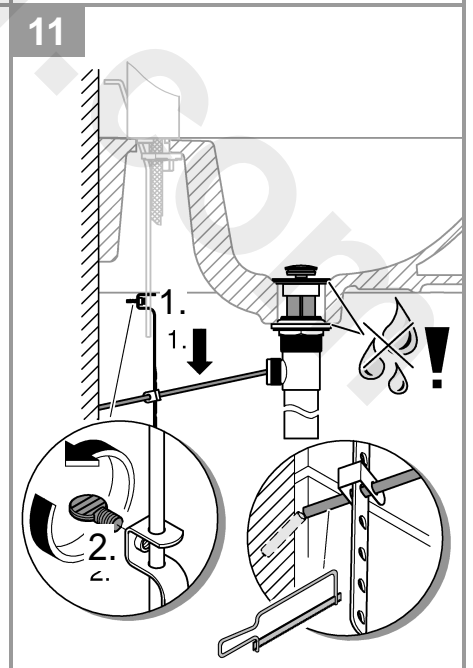
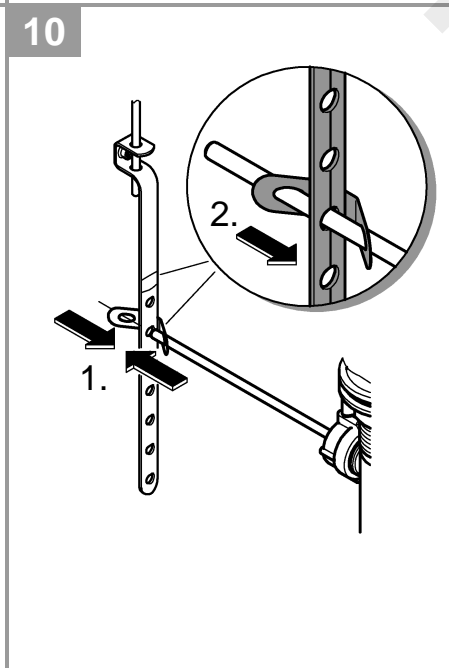
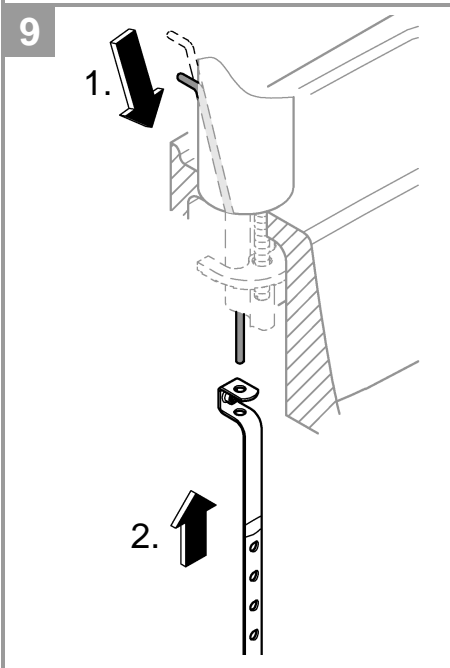
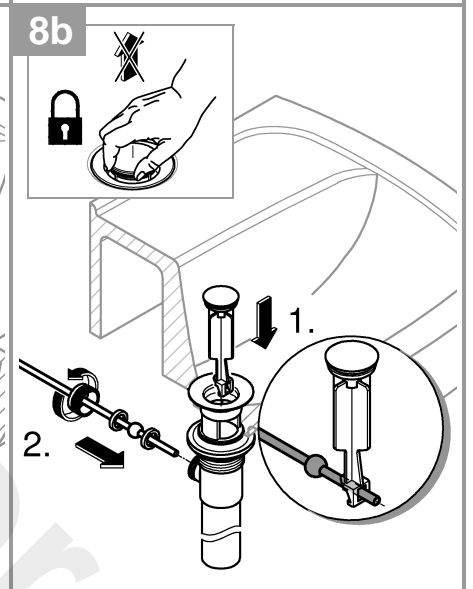
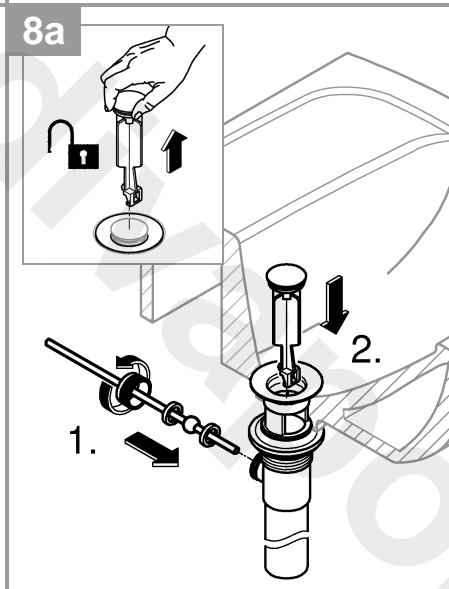
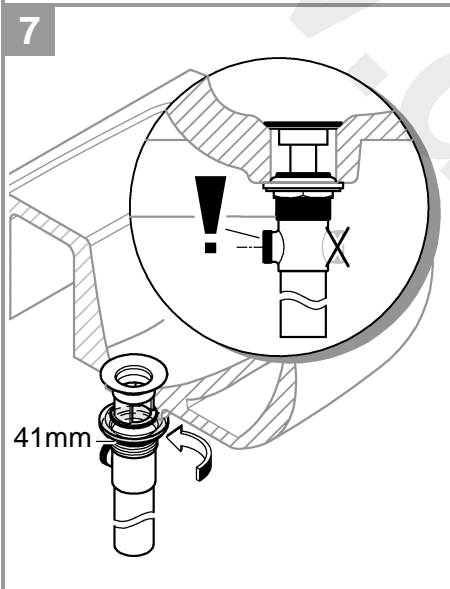
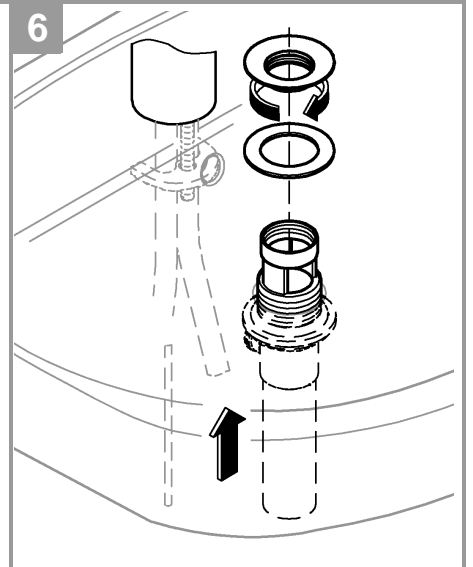
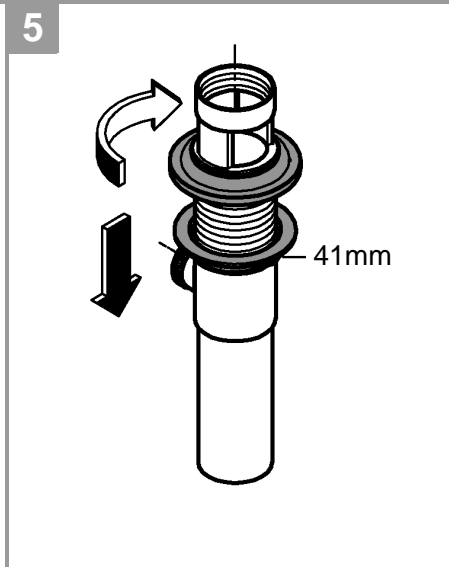
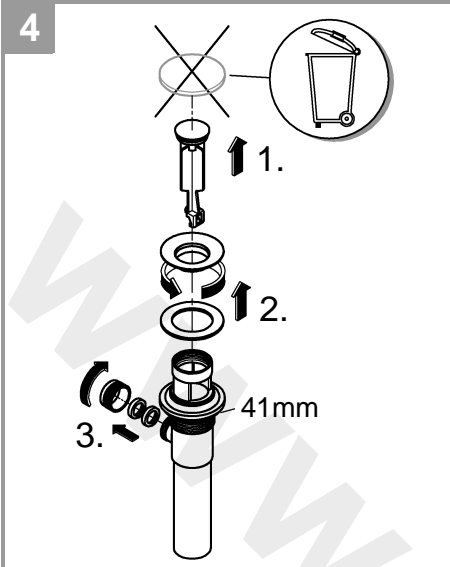

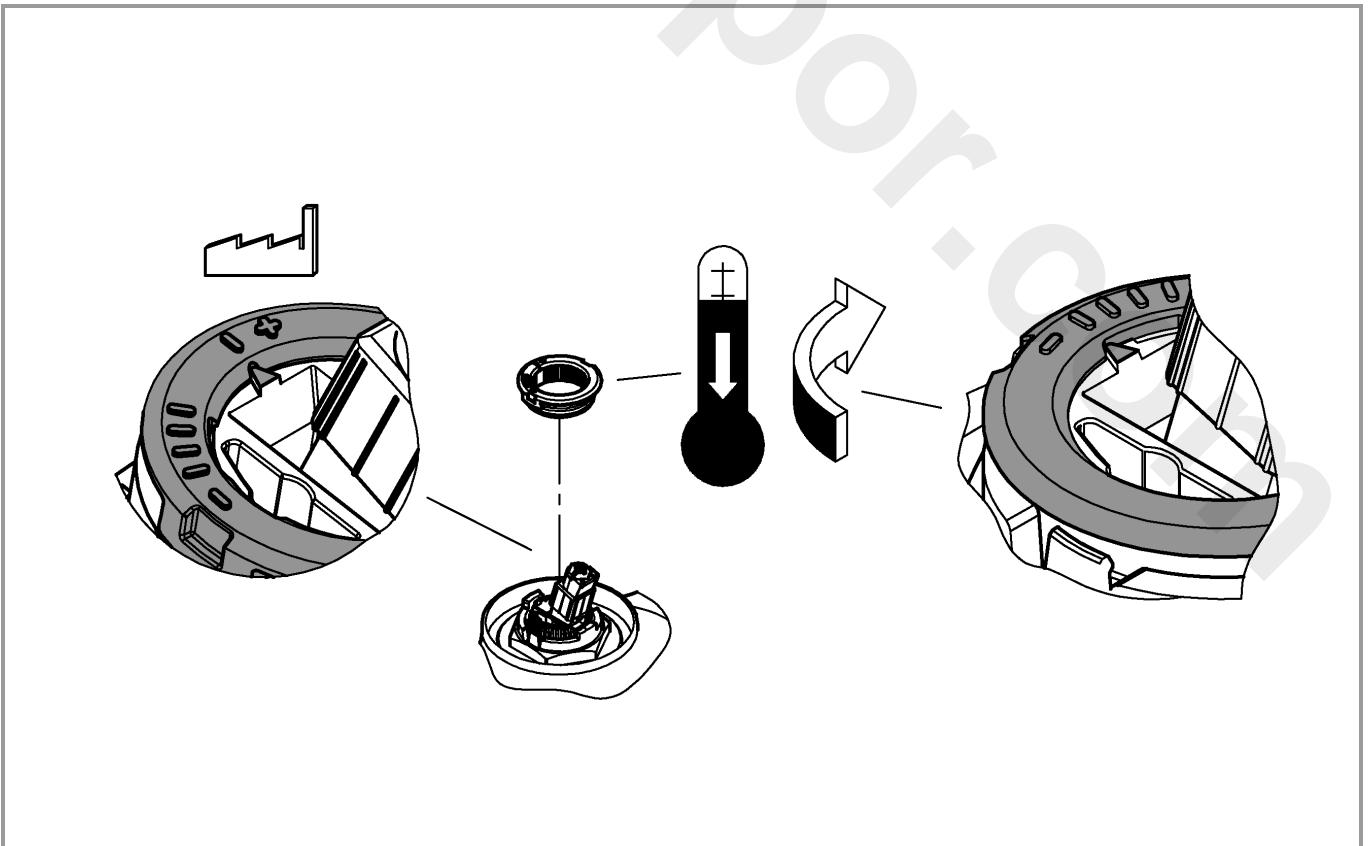
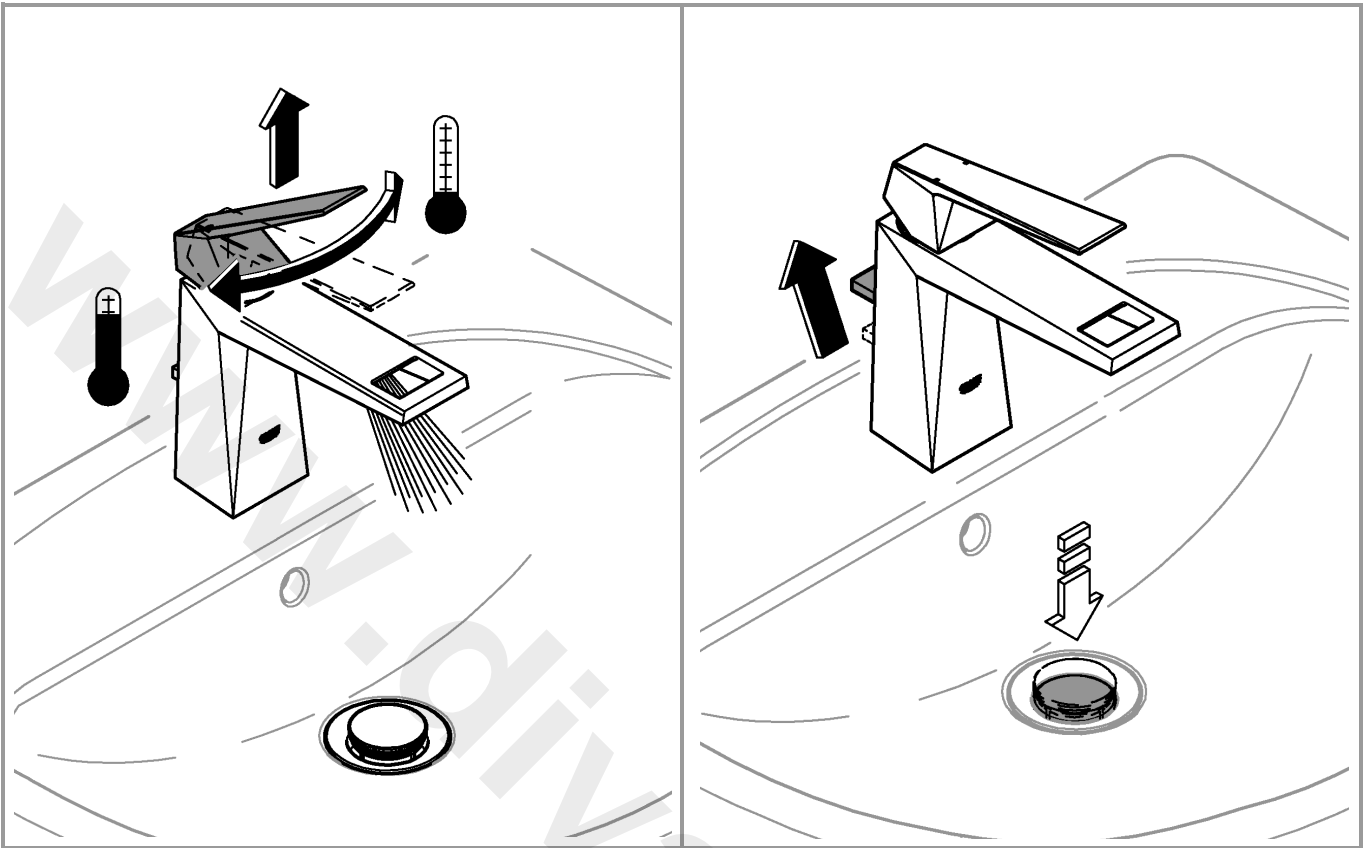
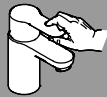

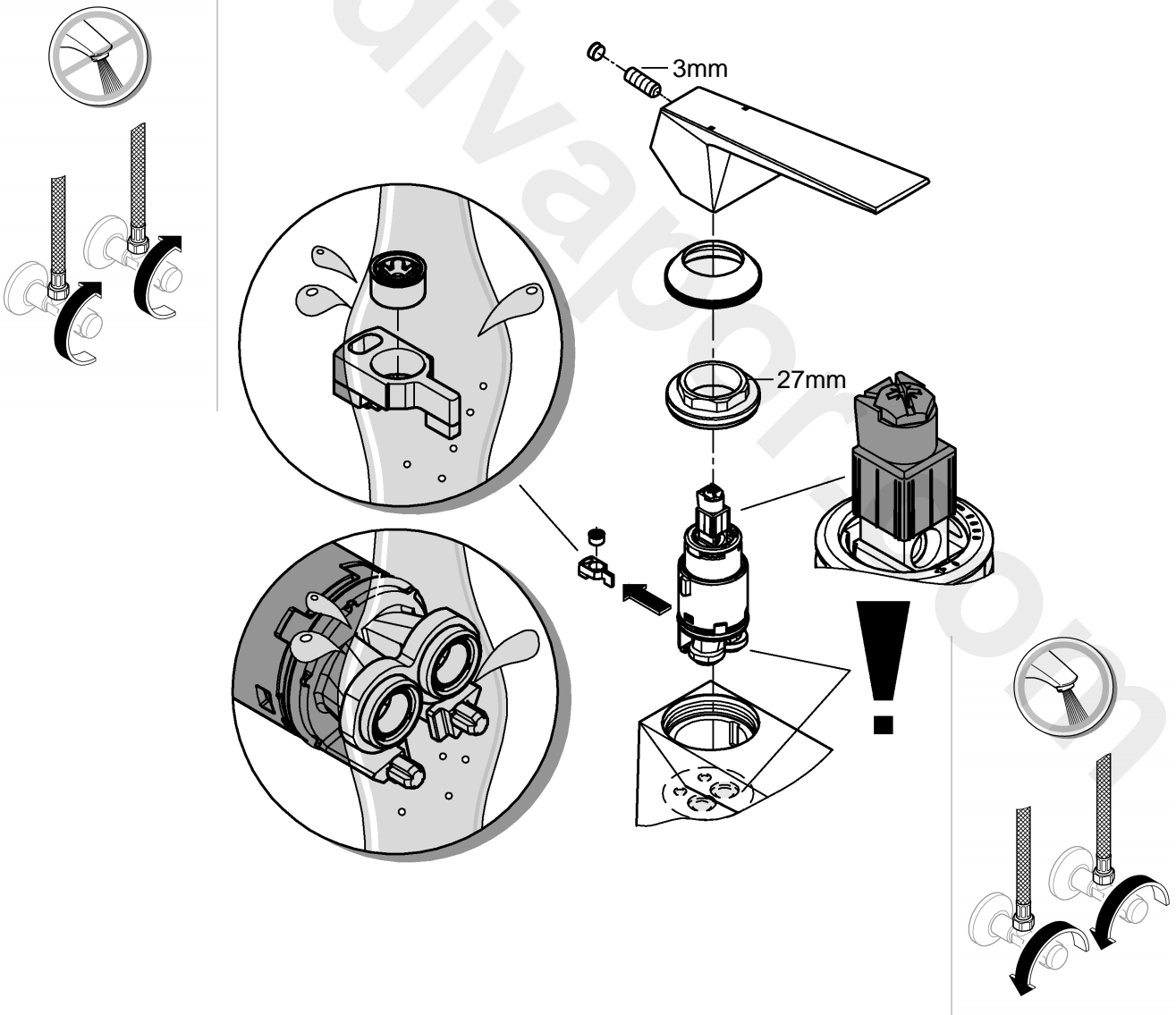
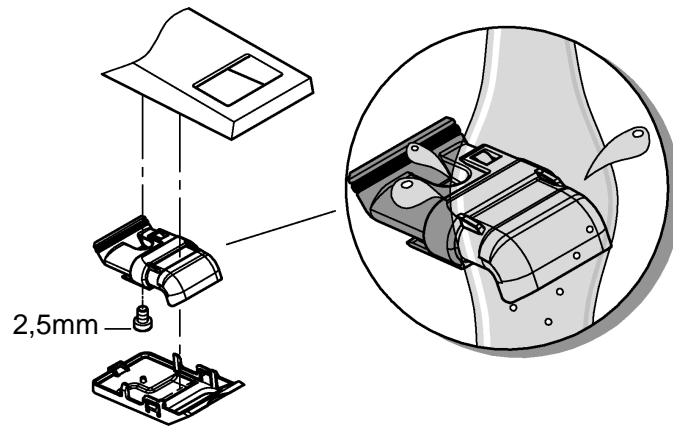

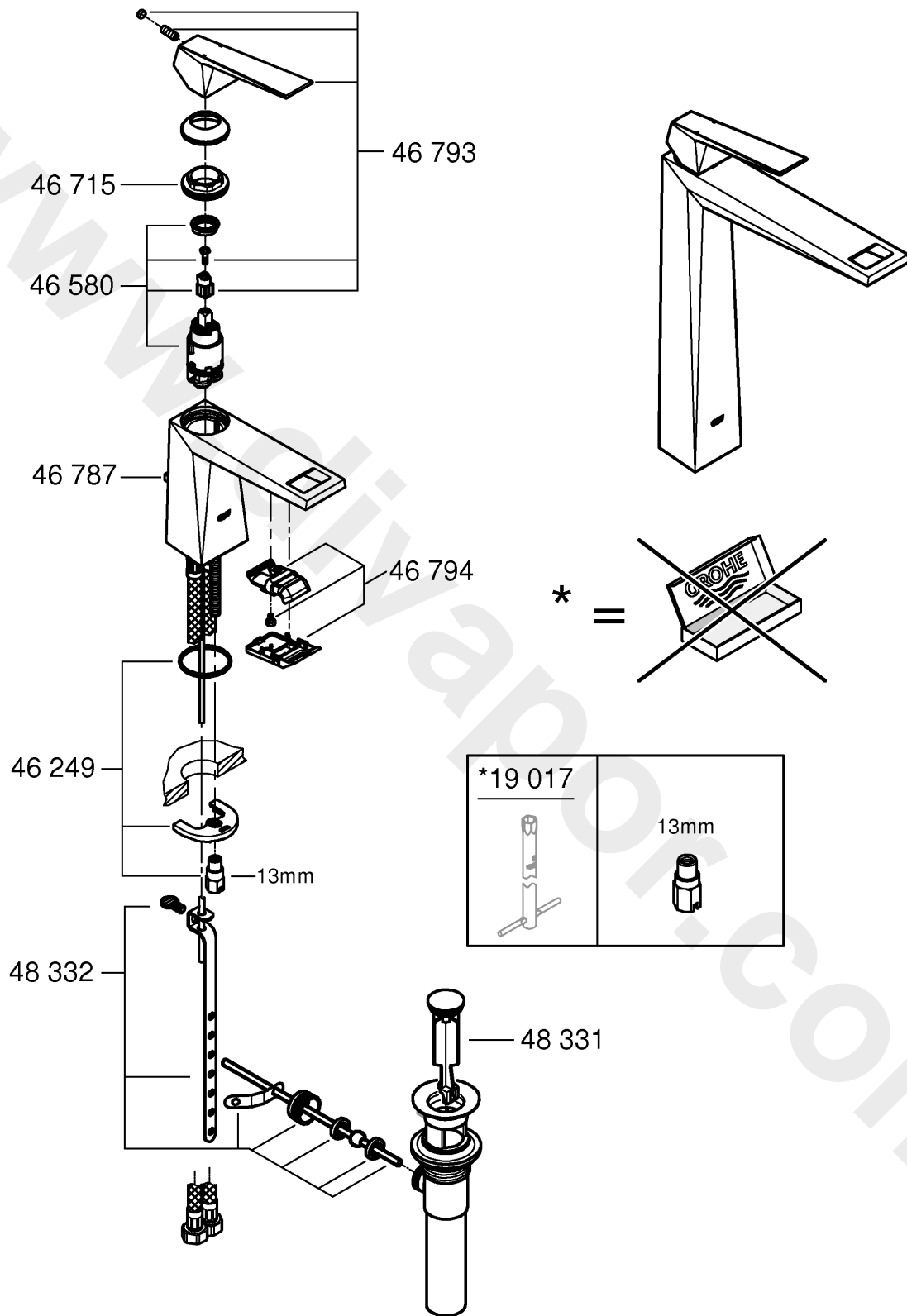

English

Application

Operation is possible in conjunction with:

- Pressurized storage heaters
- Thermally controlled instantaneous heaters
- Hydraulically controlled instantaneous heaters

Operation with low-pressure storage heaters (displacement water heaters) is **not** possible.

Flush piping system prior and after installation of faucet thoroughly!

Specifications

- Max. flow:
2303400A, 2311500A
4.5 L/min or **1.2 gpm/60 psi**
- 23034000, 23115000
5.7 L/min or **1.5 gpm/60 psi**
- Flow pressure
 - min.: 7.25 psi
 - recommended: 14.5 - 72.5 psi
 - greater than 72.5 psi, fit pressure reducing valve
- Max. operating pressure: 145 psi
- Test pressure: 232 psi
- Temperature
 - max. (hot water inlet): 158 °F
 - Thermal disinfection possible
- Water connection: cold - RH
hot - LH
- Non reversible cartridge

Notes:

- Major pressure differences between cold and hot water supply should be avoided.
- To be installed according to local codes and regulations.

Replacement parts, see page 6
(* = special accessories).

Care

Instructions for care of this faucet will be found in the Limited Warranty supplement.

Français

Domaine d'application

Le service est possible en combinaison avec:

- Des chauffe-eau à accumulateur sous pression
- Des chauffe-eau instantanés à commande thermique
- Des chauffe-eau instantanés à commande hydraulique

Un service avec des systèmes d'eau chaude à écoulement libre **n'est pas** possible.

Bien rincer les canalisations avant et après l'installation!

Caractéristiques techniques

- Débit max.:
2303400A, 2311500A,
4.5 l/min ou **1.2 gpm/4.1 bar**
- 23034000, 23115000
5.7 l/min ou **1.5 gpm/4.1 bar**
- Pression dynamique
 - min.: 0,5 bar
 - recommandée: 1 - 5 bar
 - supérieure à 5 bar, mise en place d'un réducteur de pression
- Pression de service max.: 10 bar
- Pression d'épreuve: 16 bar
- Température
 - max. (admission d'eau chaude): 70 °C
 - Désinfection thermique possible
- Raccord d'eau: froide - à droite
chaude - à gauche
- Cartouche non réversible

Remarques:

- Il convient d'éviter toute différence de pression importante entre l'alimentation en eau chaude froide et chaude.
- A installer conformément aux prescriptions et réglementations locales.

Pièces de rechange, voir page 6
(* = accessoires spéciaux).

Entretien

Vous trouverez les instructions d'entretien de ce mitigeur dans le supplément Garantie Limitée.

Español

Campo de aplicación

Es posible el funcionamiento en conjunción con:

- Acumuladores de presión
- Calentadores instantáneos con control térmico
- Calentadores instantáneos con control hidráulico

No instalar con acumuladores de baja presión (calentadores de agua sin presión).

¡Purgar a fondo el sistema de tuberías antes y después de la instalación!

Características técnicas

- Caudal máx.:
2303400A, 2311500A
4.5 L/min o **1.2 gpm/60 psi**
- 23034000, 23115000
5,7 L/min o **1.5 gpm/60 psi**
- Presión
 - mín.: 7,25 psi
 - recomendada: 14,5 - 72,5 psi
 - si la presión es superior a 72,5 psi, se deberá instalar una válvula reductora de presión
- Presión de utilización máx.: 145 psi
- Presión de verificación: 232 psi
- Temperatura
 - máx. (entrada del agua caliente): 158 °F
 - Desinfección térmica posible
- Acometida del agua: fría - a la derecha
caliente - a la izquierda
- Cartucho irreversible

Notas:

- Deberán evitarse las diferencias de presión entre las acometidas del agua fría y del agua caliente.
- A ser instalado conforme a códigos y reglamentos locales.

Componentes de sustitución, véase la página 6 (* = accesorios especiales).

Cuidados periódicos

En el suplemento Garantía a Limitada encontrará las instrucciones relativas al cuidado de esta batería.

USA

& +1 800 4447643
us-customerservice@grohe.com

www.grohe.com



CDN

& +1 888 6447643
info@grohe.ca