

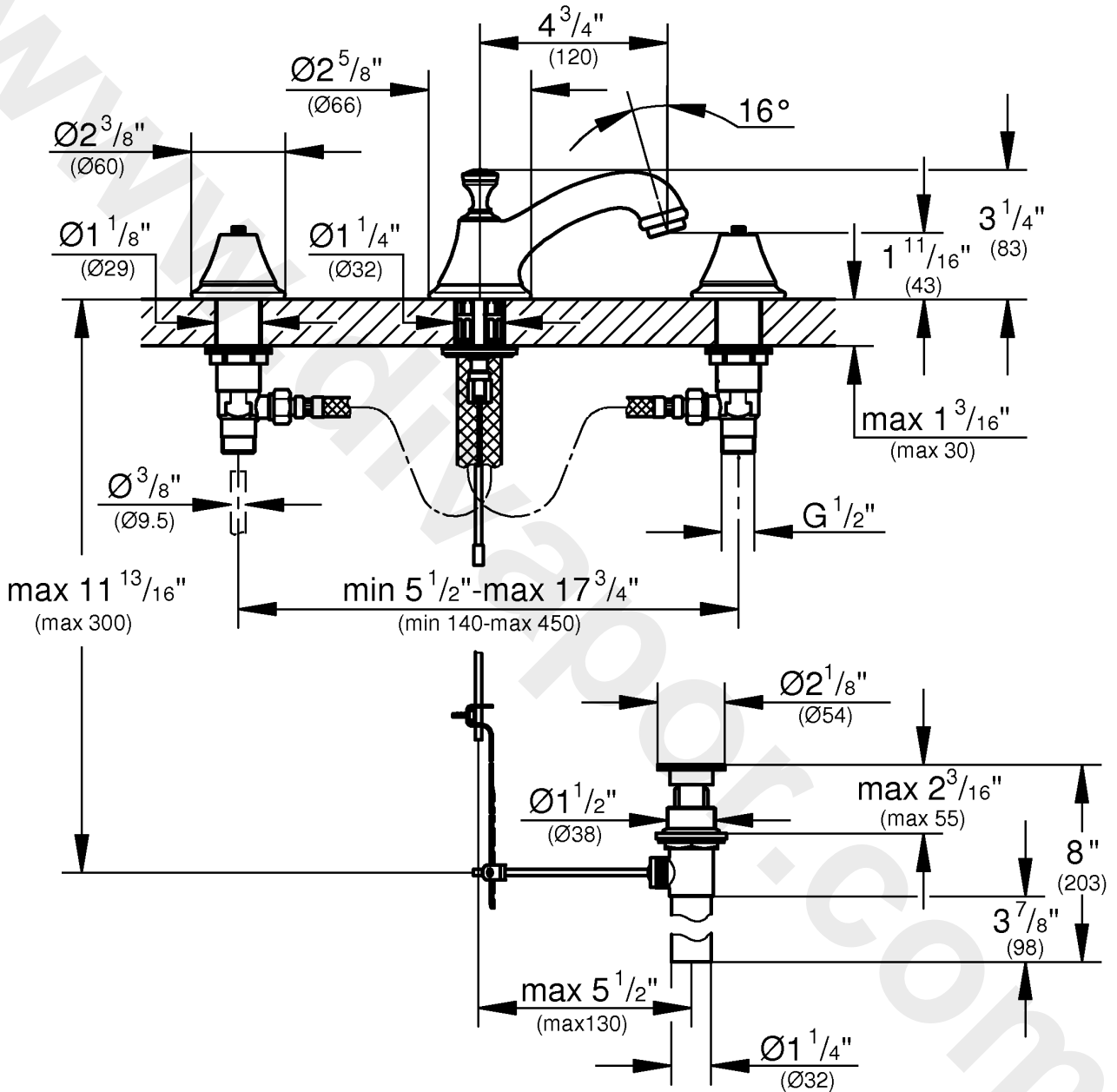

20 800



1



5

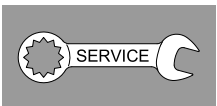

2 - 4

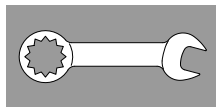

6



5

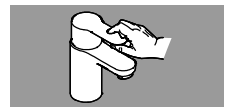

7

English  
 Français  
 Español

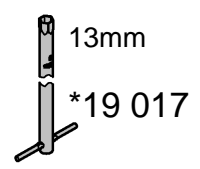
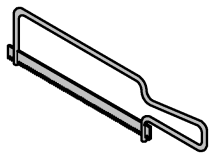
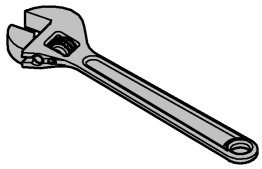
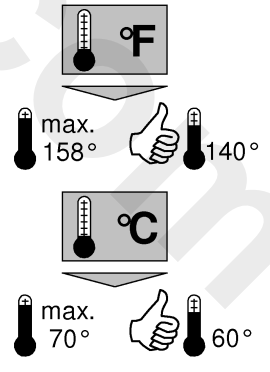
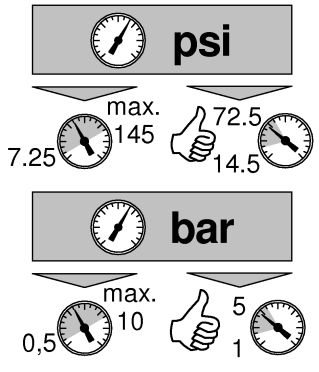
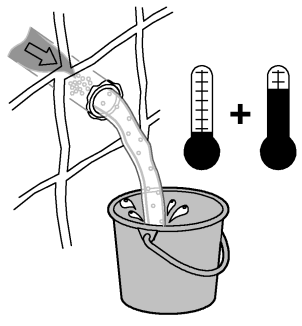
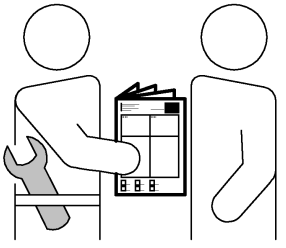
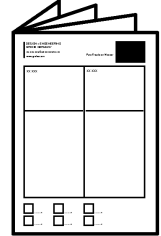
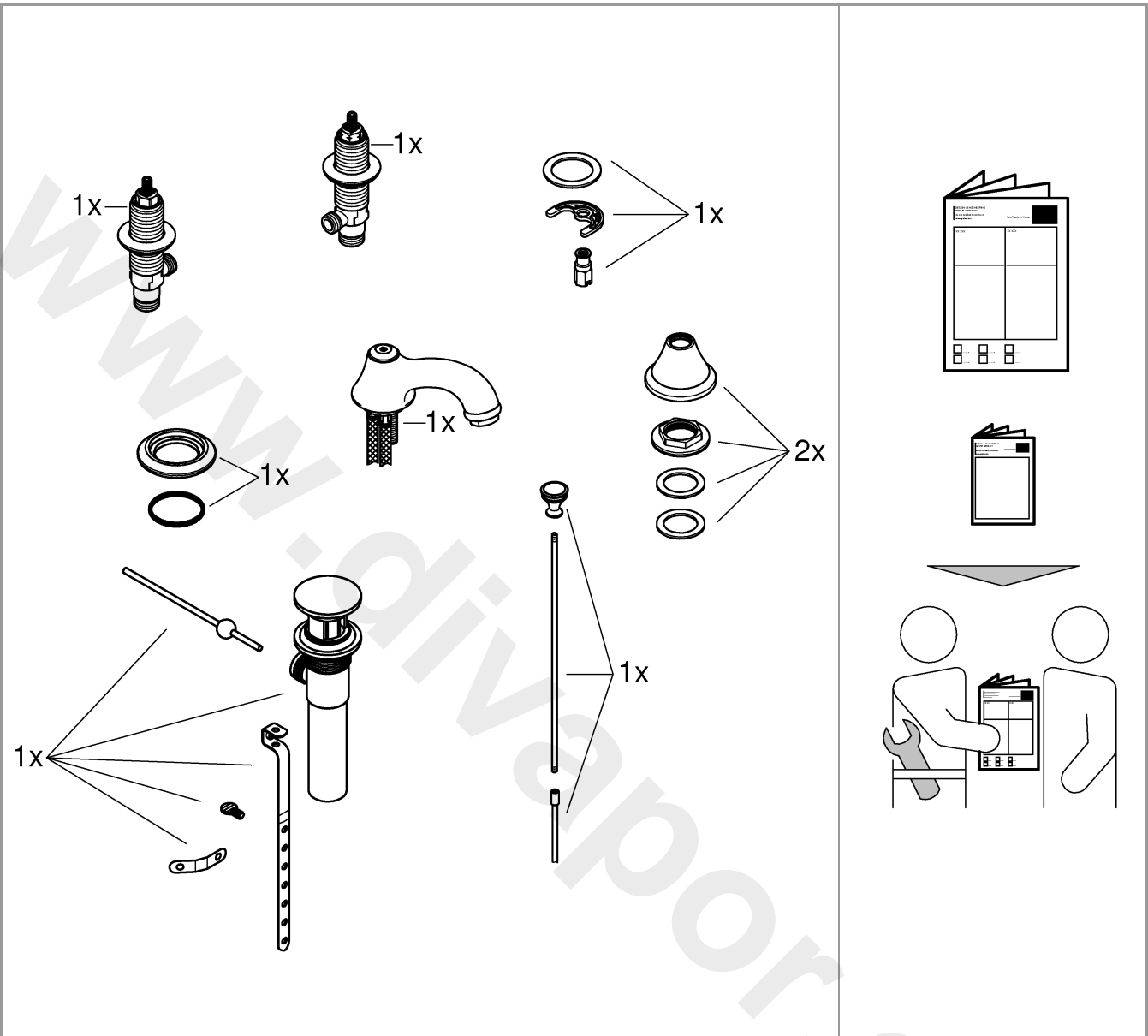



1

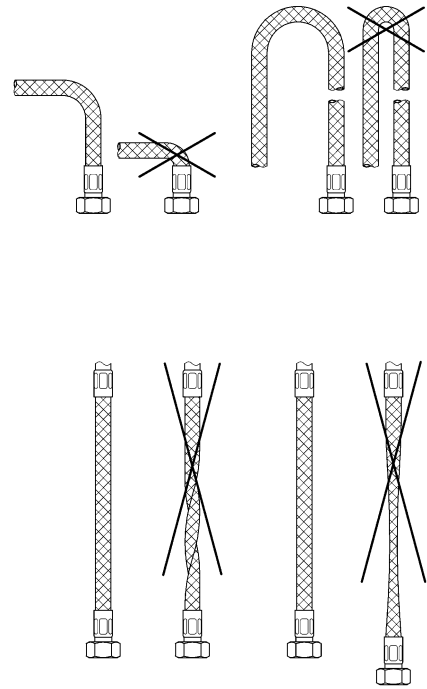
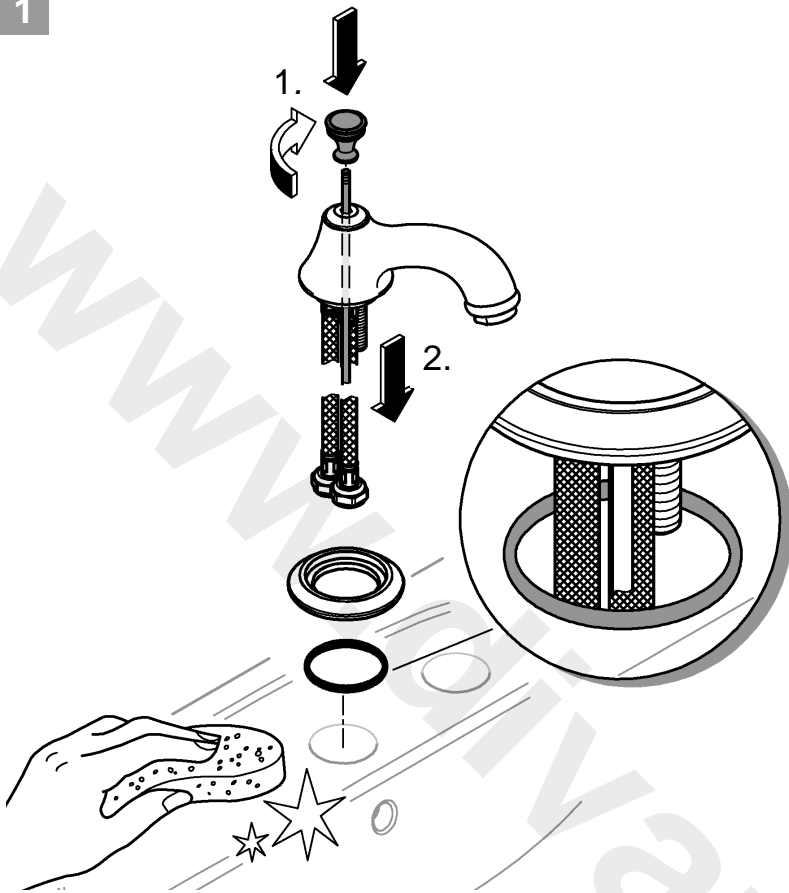

2

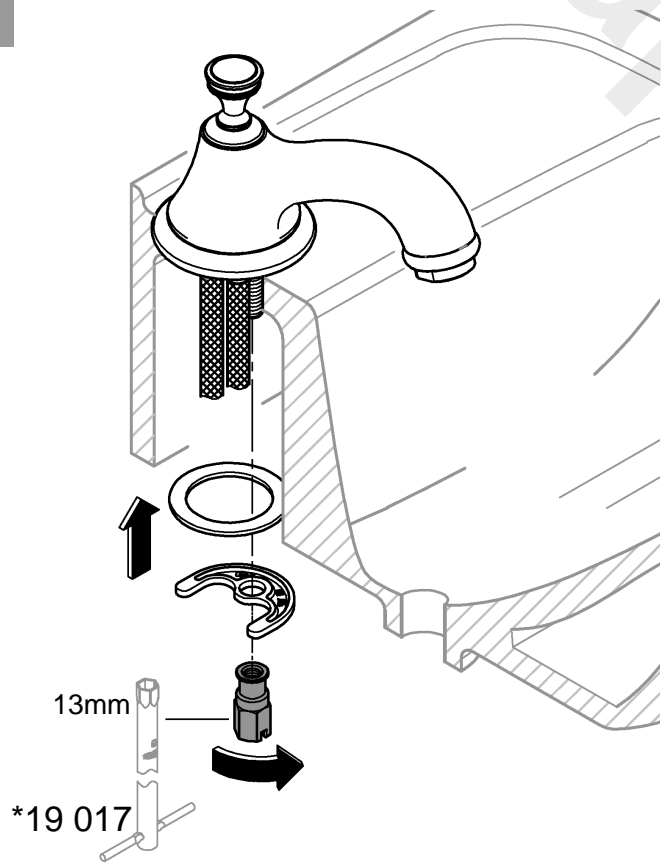

3

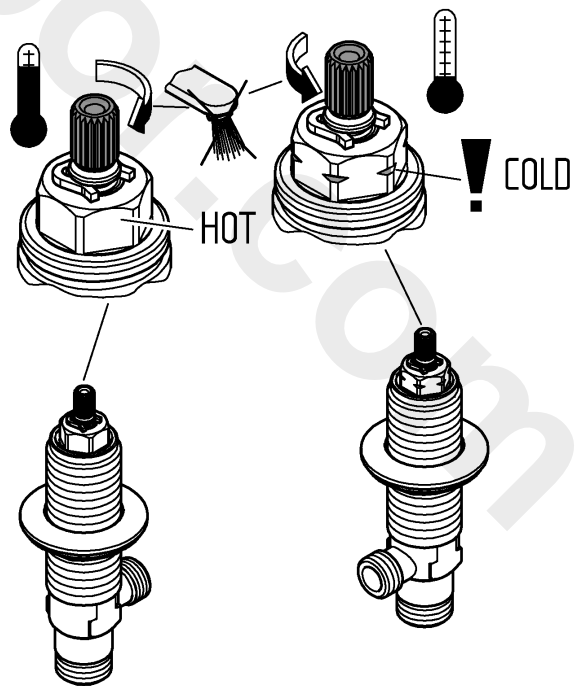



4

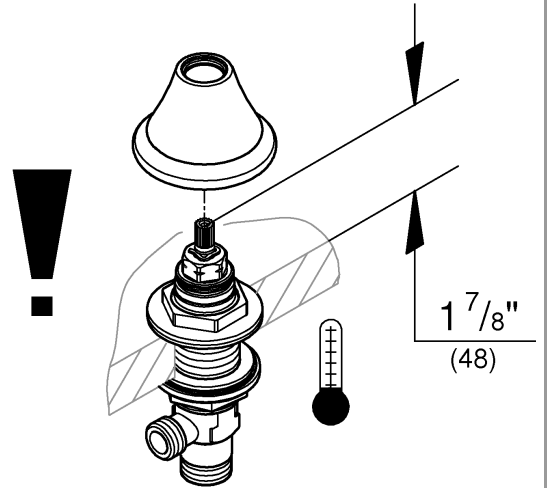
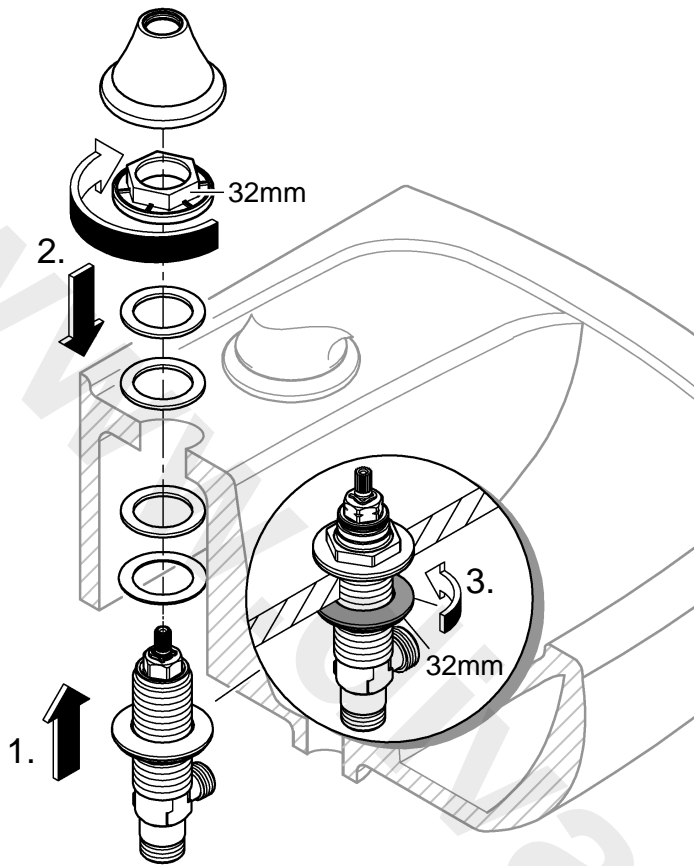

5

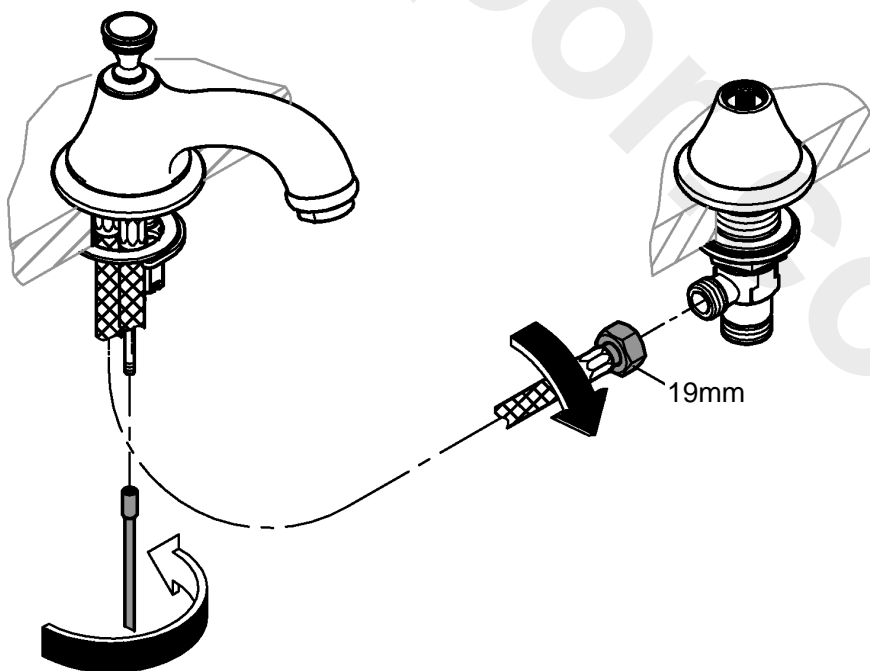

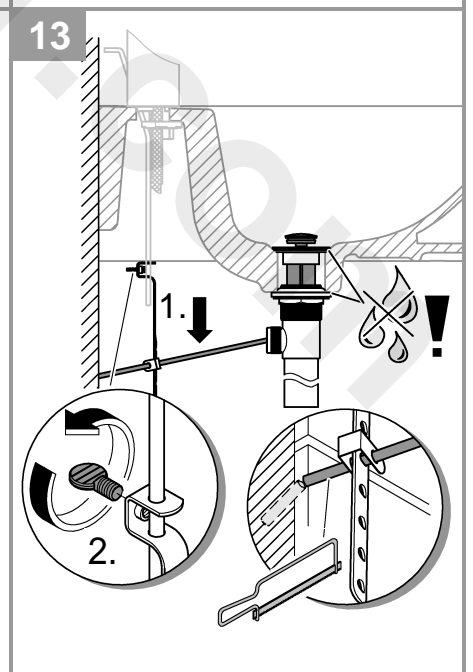
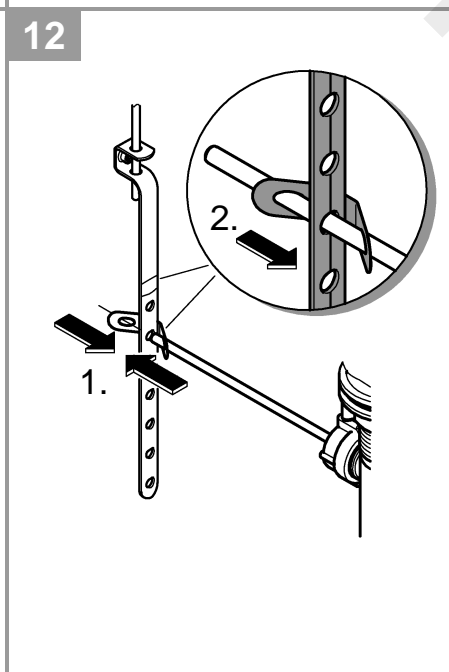
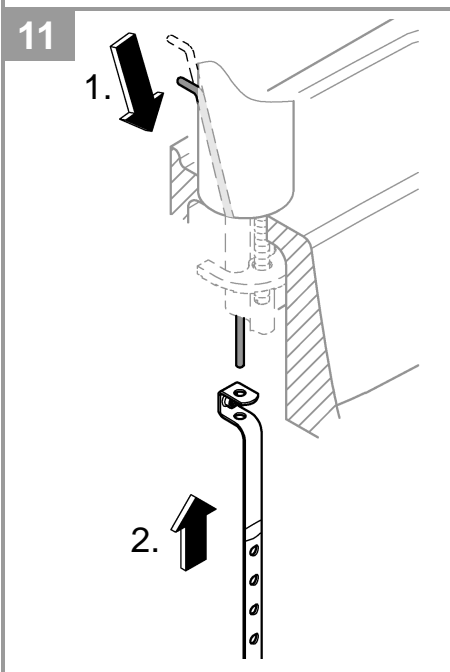
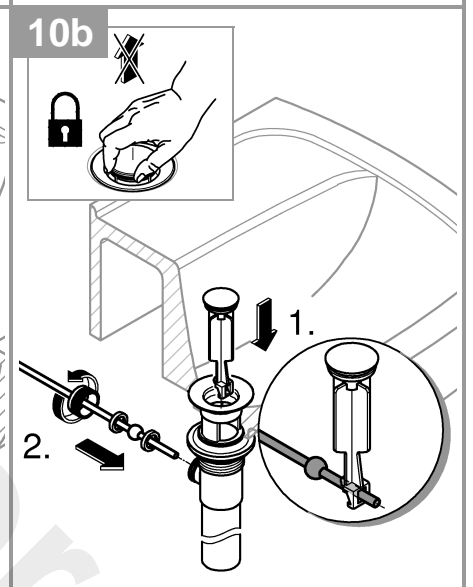
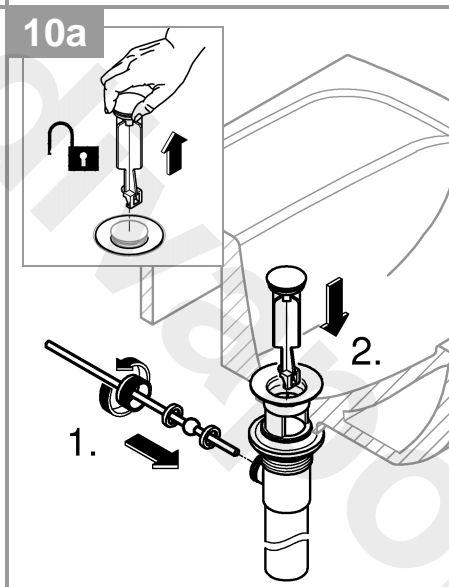
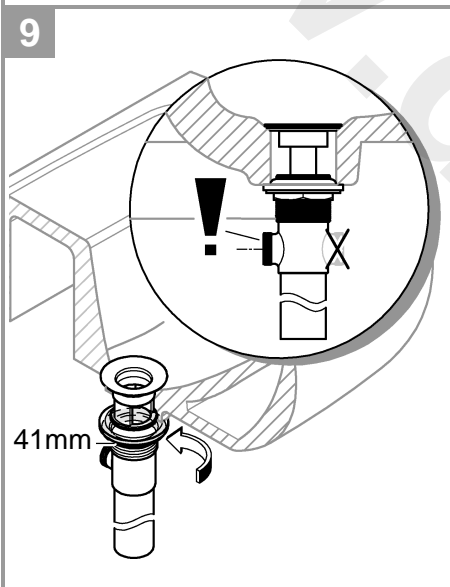
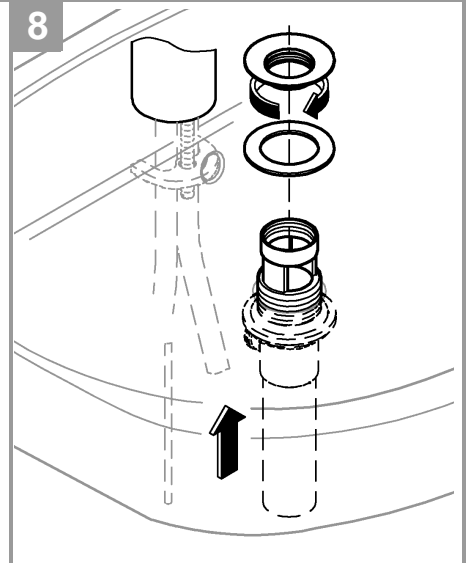
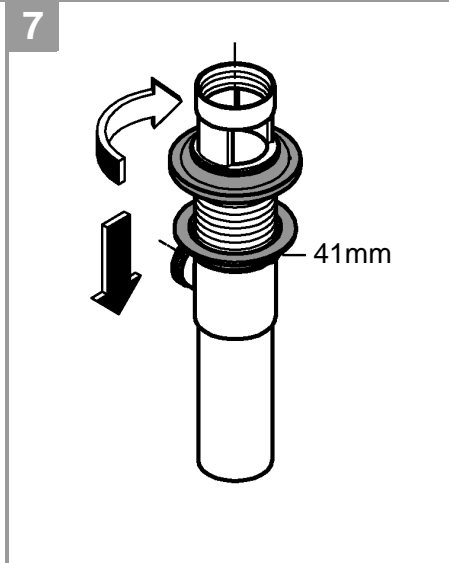
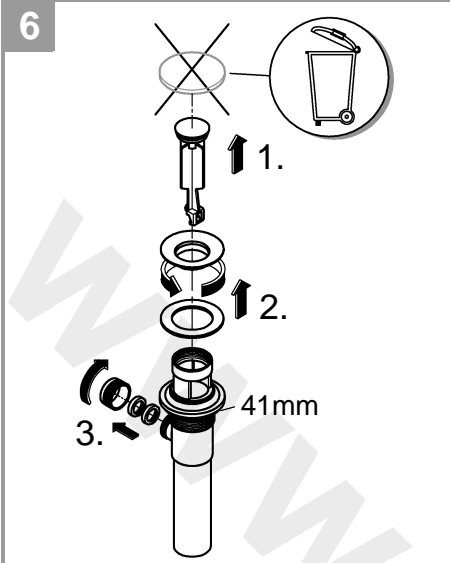

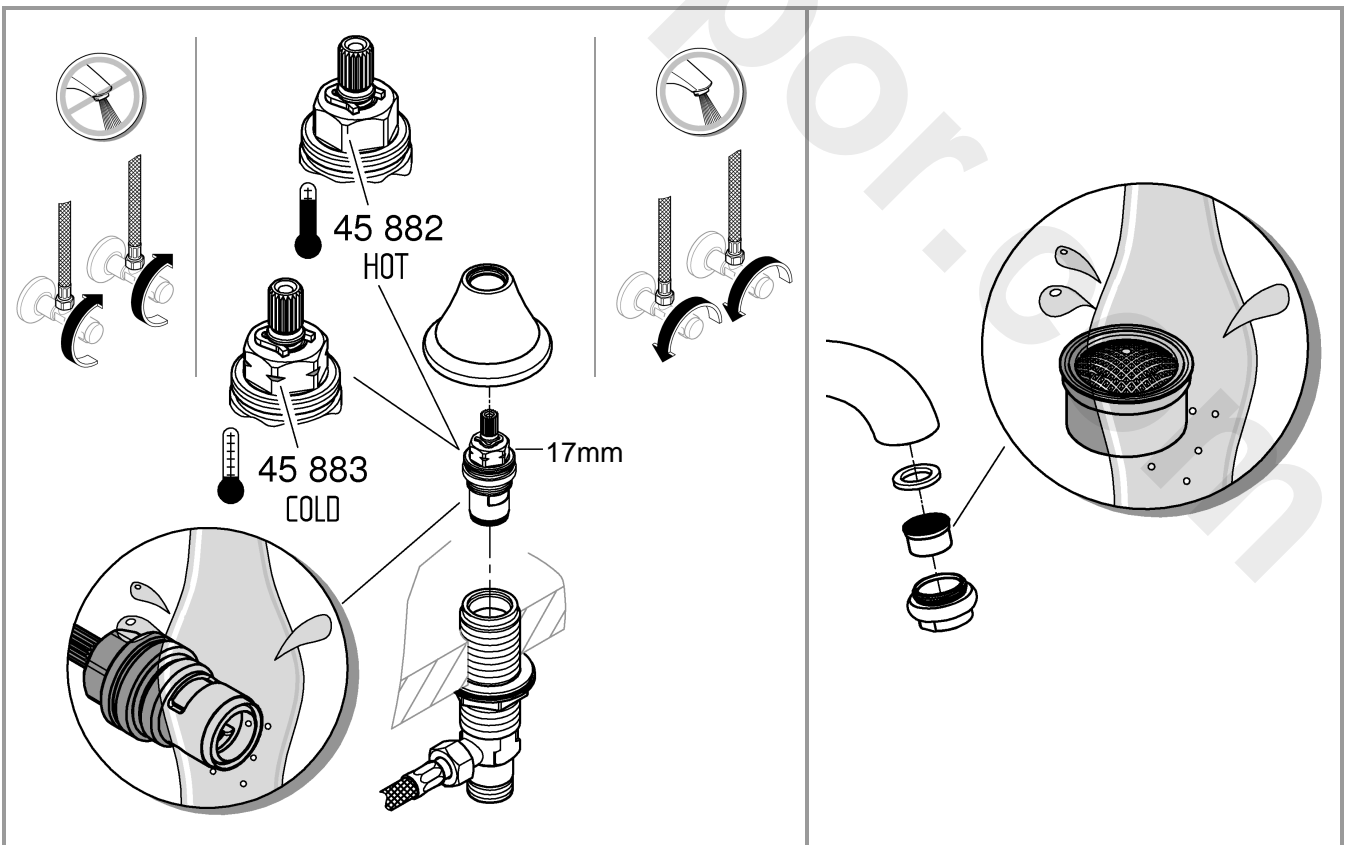
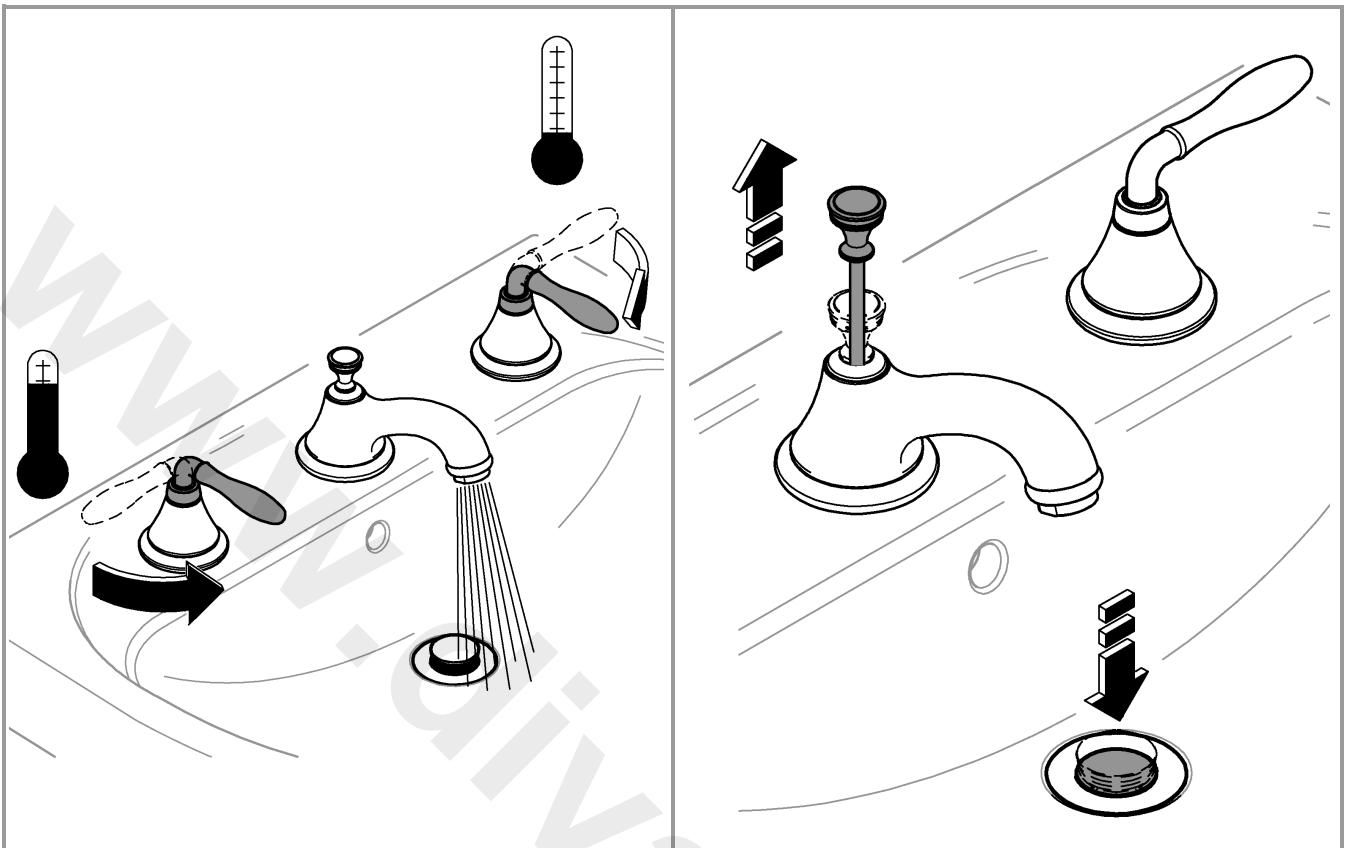
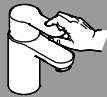

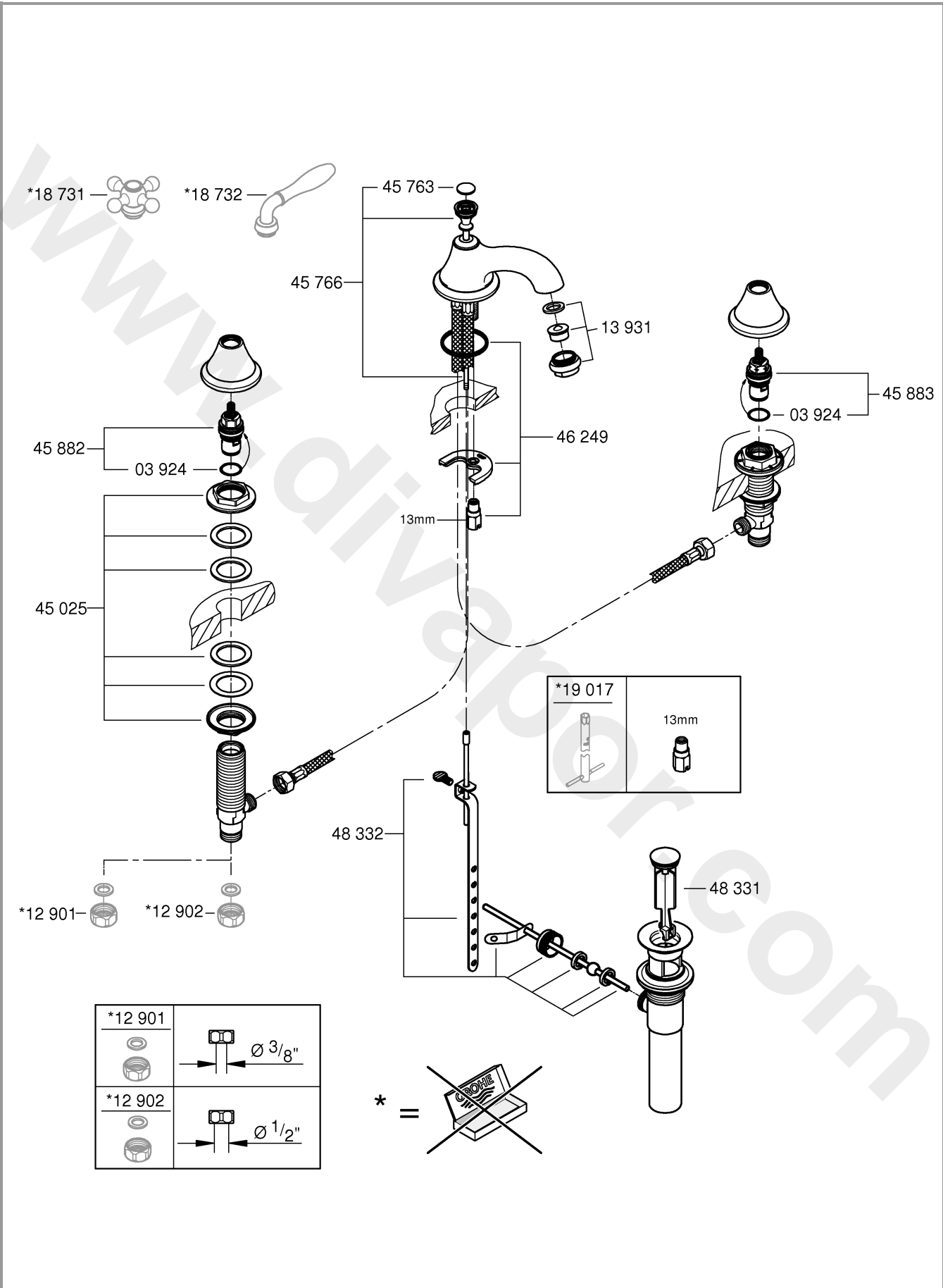

*12 901	
*12 902	

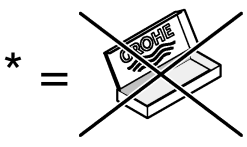

## English

### Application

Operation is possible in conjunction with:

- Pressurized storage heaters
- Thermally controlled instantaneous heaters
- Hydraulically controlled instantaneous heaters

Operation with low-pressure storage heaters (displacement water heaters) is **not** possible.

### Flush piping system prior and after installation of faucet thoroughly!

### Specifications

- Max. flow:  
2080000A 4.5 L/min or **1.2 gpm**/60 psi  
20800000 5.7 L/min or **1.5 gpm**/60 psi
- Flow pressure
  - min.: 7.25 psi
  - recommended: 14.5 - 72.5 psi
  - greater than 72.5 psi, fit pressure reducing valve
- Max. operating pressure: 145 psi
- Test pressure: 232 psi
- Temperature
  - max. (hot water inlet): 158 °F
  - Thermal disinfection possible
- Water connection: cold - RH  
hot - LH
- Non reversible cartridge

### Notes:

- Major pressure differences between cold and hot water supply should be avoided.
- To be installed according to local codes and regulations.

**Replacement parts**, see page 6 (\* = special accessories).

### Care

Instructions for care of this faucet will be found in the Limited Warranty supplement.

## Français

### Domaine d'application

Le service est possible en combinaison avec:

- Des chauffe-eau à accumulateur sous pression
- Des chauffe-eau instantanés à commande thermique
- Des chauffe-eau instantanés à commande hydraulique

Un service avec des systèmes d'eau chaude à écoulement libre **n'est pas** possible.

### Bien rincer les canalisations avant et après l'installation!

### Caractéristiques techniques

- Débit max.:  
2080000A 4.5 l/min ou **1.2 gpm**/4.1 bar  
20800000 5.7 l/min ou **1.5 gpm**/4.1 bar
- Pression dynamique
  - min.: 0,5 bar
  - recommandée: 1 - 5 bar
  - supérieure à 5 bar, mise en place d'un réducteur de pression
- Pression de service max.: 10 bar
- Pression d'épreuve: 16 bar
- Température
  - max. (admission d'eau chaude): 70 °C
  - Désinfection thermique possible
- Raccord d'eau: froide - à droite  
chaude - à gauche
- Cartouche non réversible

### Remarques:

- Il convient d'éviter toute différence de pression importante entre l'alimentation en eau chaude froide et chaude.
- A installer conformément aux prescriptions et réglementations locales.

**Pièces de rechange**, voir page 6 (\* = accessoires spéciaux).

### Entretien

Vous trouverez les instructions d'entretien de ce mitigeur dans le supplément Garantie Limitée.

## Español

### Campo de aplicación

Es posible el funcionamiento en conjunción con:

- Acumuladores de presión
- Calentadores instantáneos con control térmico
- Calentadores instantáneos con control hidráulico

**No** instalar con acumuladores de baja presión (calentadores de agua sin presión).

### ¡Purgar a fondo el sistema de tuberías antes y después de la instalación!

### Características técnicas

- Caudal máx.:  
2080000A 4.5 L/min o **1.2 gpm**/60 psi  
20800000 5,7 L/min o **1.5 gpm**/60 psi
- Presión
  - mín.: 7,25 psi
  - recomendada: 14,5 - 72,5 psi
  - si la presión es superior a 72,5 psi, se deberá instalar una válvula reductora de presión
- Presión de utilización máx.: 145 psi
- Presión de verificación: 232 psi
- Temperatura
  - máx. (entrada del agua caliente): 158 °F
  - Desinfección térmica posible
- Acometida del agua: fría - a la derecha  
caliente - a la izquierda
- Cartucho irreversible

### Notas:

- Deberán evitarse las diferencias de presión entre las acometidas del agua fría y del agua caliente.
- A ser instalado conforme a códigos y reglamentos locales.

**Componentes de sustitución**, véase la página 6 (\* = accesorios especiales).

### Cuidados periódicos

En el suplemento Garantía a Limitada encontrará las instrucciones relativas al cuidado de esta batería.

USA

& +1 800 4447643  
us-customerservice@grohe.com

www.grohe.com



CDN

& +1 888 6447643  
info@grohe.ca