

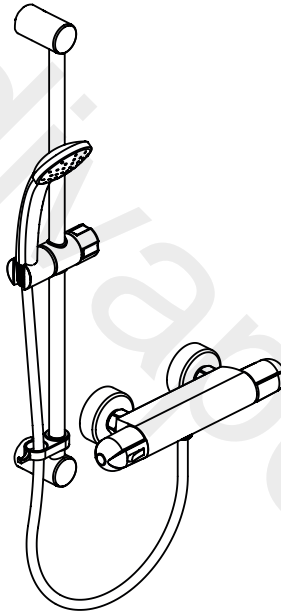

Installation Instructions

Thermostatic Bar Shower Valve

ALTO EV



A5985AA Shower thermostat with shower kit

IMPORTANT
BEFORE CONNECTION, FLUSH WATER
THROUGH PIPEWORK TO REMOVE ALL
DEBRIS ETC. WHICH COULD DAMAGE
THE VALVE MECHANISM

INSTALLER
After installation pass
to user for future reference

TABLE OF CONTENT

1	DIMENSIONS	3
2	INTRODUCTION	4
3	SUPPLY CONDITIONS	5
4	WATER REGULATIONS	6
5	INSTALLATION GUIDE	7
6	OPERATION.....	10
7	MAXIMUM TEMPERATURE STOP MAINTENANCE .	11
8	CALIBRATION.....	11
9	MAINTENANCE	11
9.1	COMMISSIONING & PERIODIC CHECKS.....	12
9.2	FREQUENCY OF REGULAR SERVICING	12
10	THERMOSTATIC CARTRIDGE REPLACEMENT.....	13
11	FLOW CARTRIDGE REPLACEMENT	14
12	CHECK-VALVE REPLACEMENT.....	14
13	CLEANING	15
14	SPARE PARTS.....	15
15	ISOLATING VALVES.....	16

1 DIMENSIONS

A5985AA

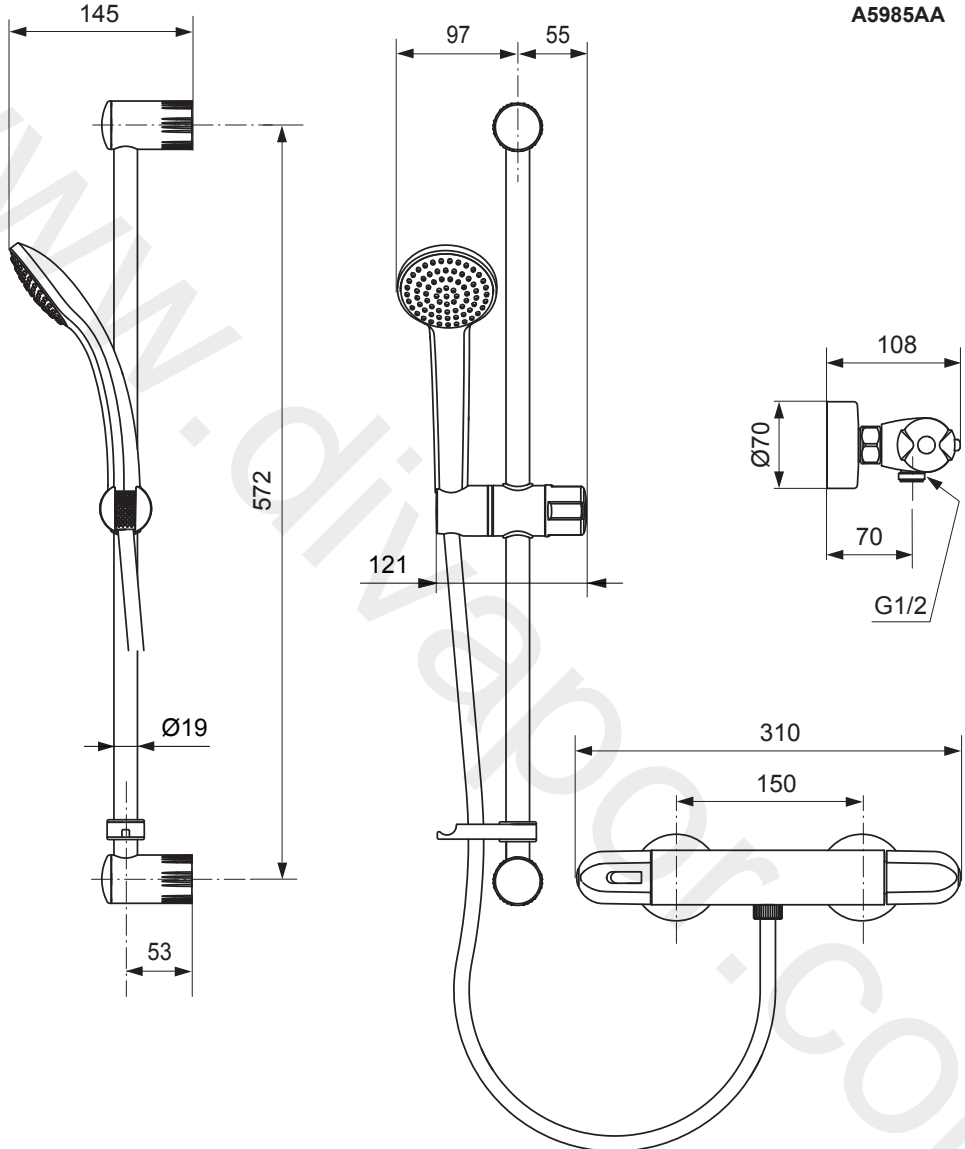

Dimensions (in millimetres) may vary within permitted tolerances

For guidance on how to install the shower kit, please refer to the separate instructions provided with the kit.

2 INTRODUCTION

The fittings covered by these instructions should be installed in accordance with the Water Regulations published in 1999*. Ideal Standard strongly recommends that these fittings are installed by a professional fitter.

*A guide to the Water Supply (Water Fittings) Regulations 1999 and the Water Byelaws 2000, Scotland is published by WRAS (Water Regulations Advisory Scheme) Fern Close, Pen-y-Fan Industrial Estate, Oakdale, Newport, NP11 3EH. ISBN 0-9539708-0-9

These thermostatic shower mixers are designed to be installed on normal UK low pressure storage tank fed systems, unvented high pressure systems, modulating instantaneous water heaters or modulating combination (combi) boilers. They are suitable for all pumped applications.

WATER REGULATIONS

Hot and cold water supply pressures must be reasonably balanced and from a common source - both from storage or both from a supply pipe. (IRN 101). The mixers will function within specification on unequal pressures up to a ratio of 5 : 1, but it is not recommended that the cold supply be connected to the rising main and hot to the tank fed supply as the pressure differential is likely to exceed the 5:1 ratio. (**See table 1**) The minimum pressure for correct operation is 0.1 bar (1m head). Pressure head is measured as the vertical distance between the bottom of the cold water storage tank which feeds the hot water system and the highest point on the shower spray plate. When installing with a shower pump the use of a secondary tapping from the cylinder is highly recommended.

The picture below shows the various methods of connecting the hot water pipe to the cylinder - the most preferred on the left and the least preferred on the right.

The fitting should be so installed as to be readily accessible for examination, repair, replacement or operation. (IRN 111).

The temperature of the hot water must not exceed 85°C but the installer's attention is drawn to code of practice BS 6700 which recommends that stored hot water should normally never exceed 65°C. For correct operation of the valve, a minimum of 55°C is required.

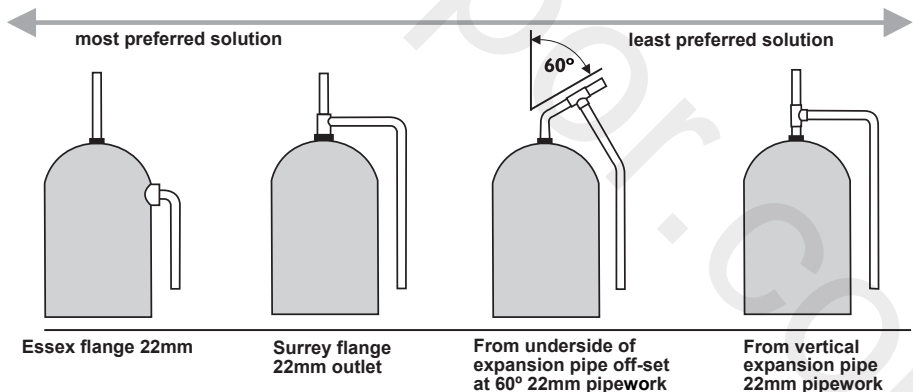

Preferred arrangements for cylinder tapping

In accordance with BSEN1111 & BSEN1287 the valve has approval for the following applications:

High Pressure HP-S
Low Pressure LP-S

Note: If water supply is fed by gravity then supply pressures should be verified to ensure the conditions of use are appropriate for the valve.

3 SUPPLY CONDITIONS

Table 1 Conditions of use for Type 2 valves

	BSEN1111	BSEN1287
Operating pressure range:	High Pressure	Low Pressure
Maximum static pressure	10 bar	10 bar
Flow pressure hot and cold	0.5 to 5.0 bar	0.1 to 1.0 bar
Hot supply temperature	55 to 65 °C	55 to 65 °C
Cold supply temperature	up to 25 °C max	up to 25 °C max
Temperature differential characteristic (TDC)	10 °C	10 °C

Valves operating outside of these conditions cannot guaranteed to perform as type 2. Approval only applies when the valves are installed without the flow regulators.

MODULATING COMBI BOILER

This thermostatic shower valve is designed for use with modulating combination boilers.

When installing on a modulating combination boiler it is sometimes possible for the interaction of a thermostatic valve with the combi to cause the boiler to cut out and cut in again, with the result that the water will become alternatively cold and hot. To overcome this, a 4 L/min flow regulator should be fitted upstream of the thermostatic valve.

It should be fitted in any 15mm compression fitting in the dedicated cold supply pipe.

It is important to choose a compression fitting located in a position which is accessible after installation and it must be fitted the correct way round for the direction of flow. The regulator can be fitted in either the inlet or outlet side of the compression fitting. If fitting in an outlet side, ensure the o-ring is seated fully in the visible rebate around the edge of the regulator. Use the tip of a small screwdriver or similar to achieve this. Ensure the tail of the pipe is not fouling the regulator (shorten if required) and do up the compression fitting as normal. In a minority of cases, where the boiler is of a type which stores a small quantity of very hot water, it may also be necessary to fit a 4 l/min flow regulator in the hot supply.



flow direction
through
flow regulator

These regulators (code A962570NU) can be obtained by contacting fastpart:



For more information on spare parts why not visit our spare website:
www.fastpart-spares.co.uk
or contact customer care

Excessive flowrate

To remedy an excessive flowrate issue, where the above inlet regulators have not been fitted, we recommend the use of a “shower outlet flow regulator”. This is suitable for installations which exceed 2 bar dynamic pressure.

A 9 litres per minute outlet regulator is available, quote spares code L6749AA.

This regulator can be easily fitted between the shower valve outlet and the shower hose

Isolation valves MUST be fitted to permit future maintenance. Fitting of strainers is also recommended.

These should be fitted as close as is practicable to the water supply inlets of the thermostatic shower valve. See sect.15 for more details.

Both isolation valves & strainers should be installed in an easily accessible location.

4 WATER REGULATIONS

CATEGORIES OF RISK

The water regulations published in 1999* take a new approach to backflow in that they look at different categories of risk. The installer must assess the risk from the various categories of fluid in adjacent appliances before determining the level of backflow protection required for a particular installation. **Figures 3 & 4** describe the protection required in various installations.

CATEGORY 3 RISK

Water in a shower tray, basin or bathtub is considered to be a fluid category 3 risk which is a fluid which represents a slight health hazard if it were to find it's way back into the supply pipe. For this reason it must not be possible for any flexible shower head to be able to enter any adjacent washbasin, bath or shower tray unless appropriate protection is employed. **(See Figure 3)**. If it is desired to allow the hand spray to be used inside say a bathtub or a basin it is essential that double check valves be fitted to the inlet on both hot and cold supplies to the thermostatic valve. Alternatively single check valves can be fitted at the inlets and an additional check valve should be fitted in the valve outlet.

No check valves need be fitted if the hand spray is prevented from reaching closer than 25mm of the spill over level of any such fixture.

CATEGORY 5 RISK

Water in a Sink, WC or Bidet is considered to be a fluid category 5 risk which is a fluid which represents a serious health hazard if it were to find it's way back into the supply pipe. For this reason it must not be possible for any flexible shower head to be able to enter any adjacent Sink, WC or Bidet. If the flexible hose to be fitted could reach into any such vessel, the requirements to the system design are so onerous it is better not to fit a flexible. Rather, a fixed overhead showerhead should be considered. **(See Figure 4)**.

It will also be seen that this risk could change should the hose be taken out of the restraining device or should a longer replacement hose be fitted at a later date. Installers and householders are advised to take account of these factors when fitting replacement hoses. For pumped applications the pipe supplying the pump must not in addition supply an ascending spray bidet.

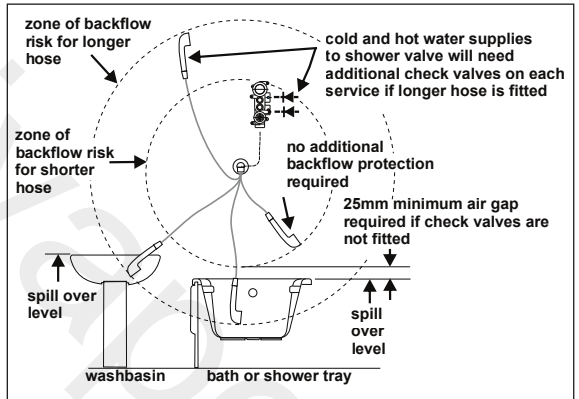

Fig. 3 Backflow risk from a fluid category 3

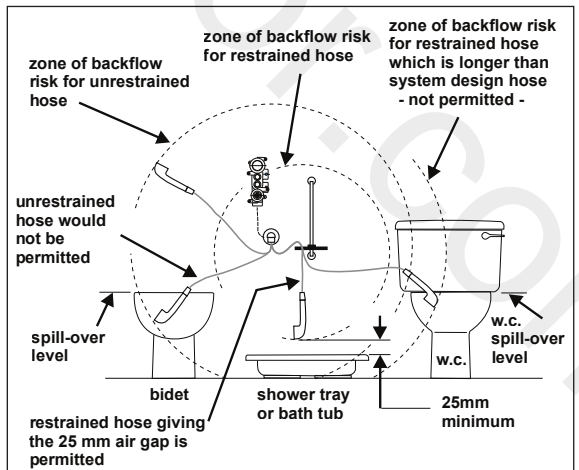
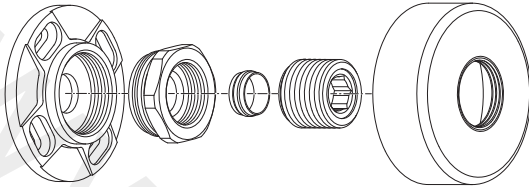

Fig. 4 Backflow risk from a fluid category 5

5 INSTALLATION GUIDE

The thermostatic mixing valve must be installed in such a position that maintenance of the TMV and its valves and the commissioning and testing of the TMV can be undertaken.

Kit CONTENTS



BRACKET WITH ADAPTOR X 2

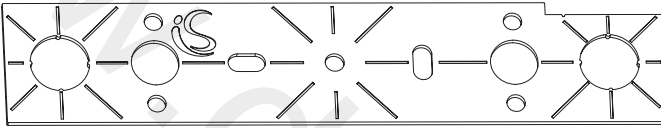

TEMPLATE x 1

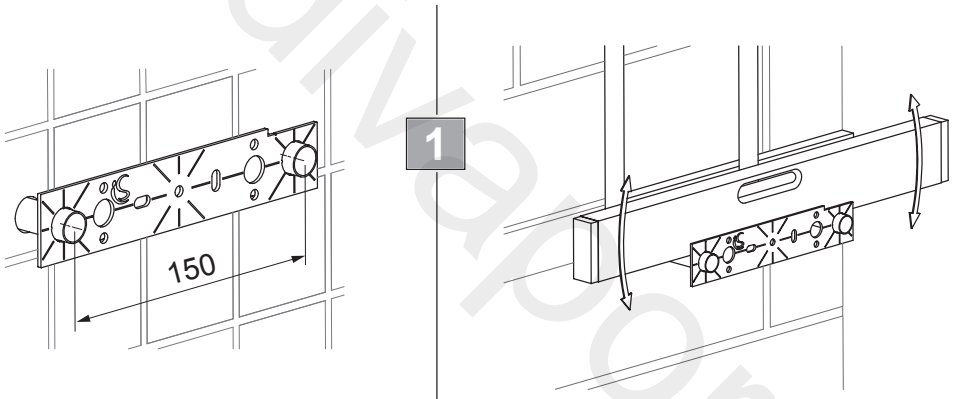

Ø15mm copper supply pipes should be run within the wall cavity.
Hot supply pipe should be on the left hand side and the cold on the right.
Ensure that the hot and cold pipes are positioned 150mm apart and are level.
Use the template provided to obtain the correct spacing.

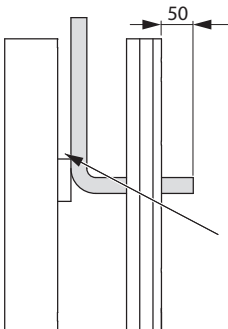

We recommend leaving 50mm of pipe protruding at this stage.

Pipework should be supported in the cavity

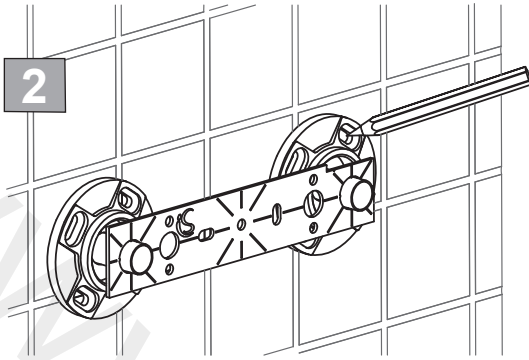

Place the brackets over the exposed pipes and use the template provided to position them 150mm apart.

Mark the hole positions for the fixings onto the mounting surface.

Ensure that the positions of the holes will not result in damage to the pipework inside the wall cavity during drilling.

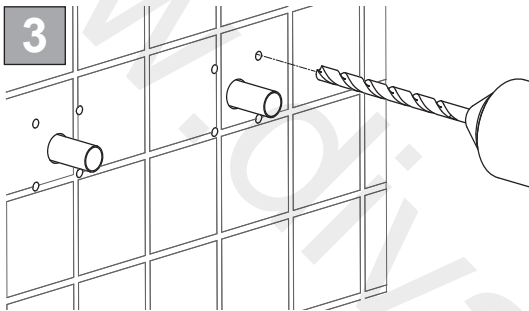

Drill holes appropriate for your choice of fixings into the wall.

We recommend a minimum of two fixings per bracket diametrically opposed.

Drill carefully to avoid damaging concealed pipework.

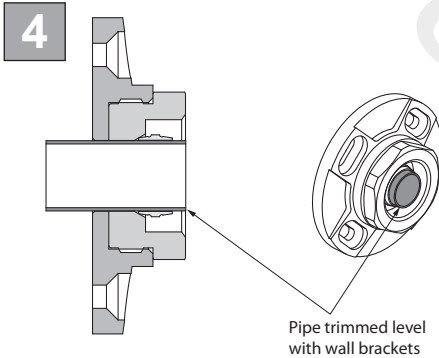

The pipes should be trimmed level to the wall bracket. If using a pipe cutter it will be necessary to mark the pipes and then remove the bracket before trimming to its correct length.

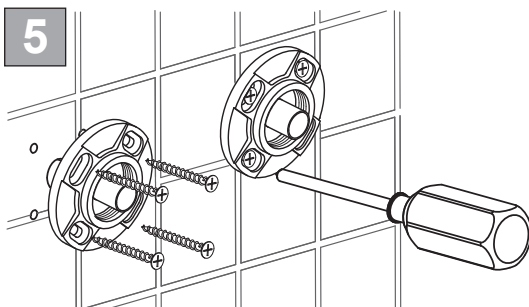
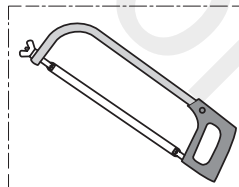

Apply a smear of silicone sealant to the rear of the assembled brackets and push them over the pipework.

Screw both brackets to the wall.

The template can be used to check that the correct pipe spacing of 150mm has been maintained.

Clean off excess sealant and flush the pipes to remove any trapped debris.

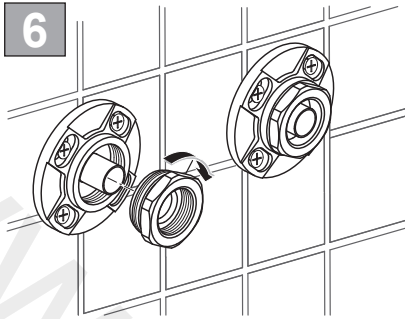

Screw the brass adaptors over the pipes into the plastic brackets. 36mm A/F Spanner flats are provided, hand tightness is adequate.

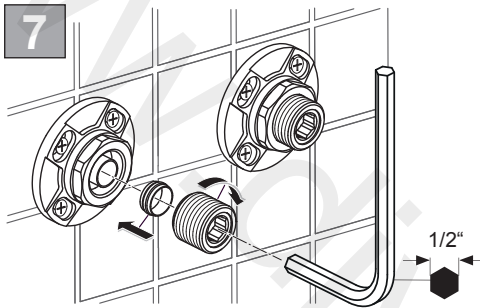

Fit the olives to the pipes prior to screwing the two 3/4" connectors into the wall mount plate using a 1/2" allen key. The connectors will have to be securely screwed in to form the necessary compression joint between the olive, wall plate and connector. Retain the brass adaptors with a spanner when making the compression joints.

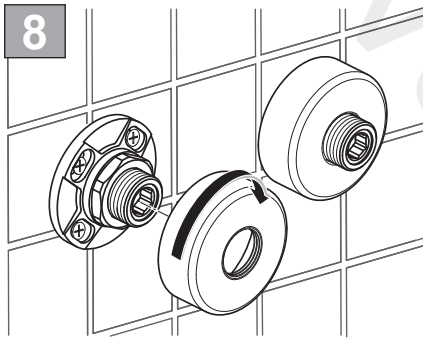

When the sealant has set, fit the covers by screwing them onto the adaptors until they are flush with the wall.

The covers only need to be hand tight.

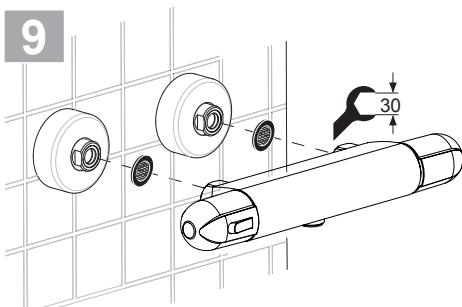

Assemble the shower valve to the adaptors remembering to ensure that the sealing washers or filters are inserted between the adaptors and the shower valve inlets.

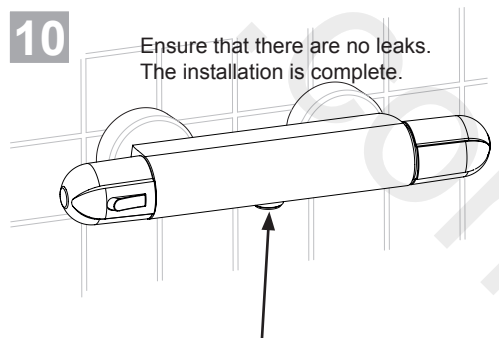

10

Ensure that there are no leaks. The installation is complete.

Finally connect the shower hose to the outlet on the under side of the shower valve, ensuring seal is in position.

6 OPERATION

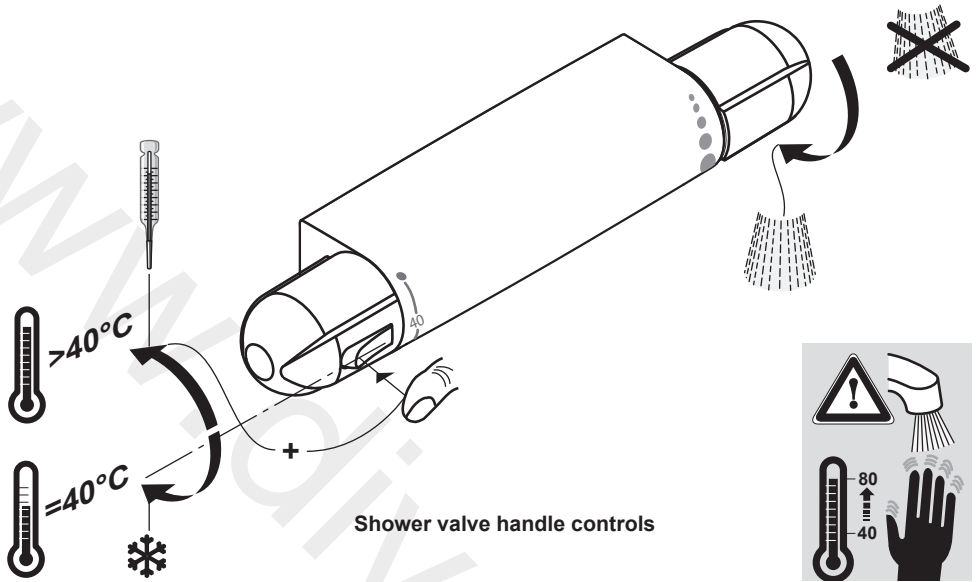

ATTENTION:
TEMPERATURES HIGHER THAN 40°C CAN BE HARMFUL TO YOUR HEALTH.

Right handle controls water flow rate.

- This handle is shown above in the off position.
- Rotating this handle downwards commences water flow.
- To obtain greater flow rate, rotate this handle further downwards.

Left handle controls water temperature.

- This handle is shown above in the 40°C temperature position.
- At this temperature "stop" position mixed water is delivered about 40°C.
- To obtain cooler water rotate handle downwards.
- To obtain higher water temperature, press the left safety button and then rotate this handle upwards.

**DO NOT FORCE HANDLES BEYOND THE DESCRIBED MOVEMENT RANGES
OTHERWISE THIS MAY RESULT IN DAMAGE TO BOTH VALVES AND HANDLES.**

7 MAXIMUM TEMPERATURE STOP MAINTENANCE

The maximum mixed water temperature is factory set at 40°C.

To change this temperature, remove the temperature control handle.

Remove the temperature limit stop (black H-shaped plastic part) and reinsert it in the appropriate recess on the handle carrier.

Four different settings are possible:

40°C, 43°C, 45°C (&50°C).

Finally refit the temperature handle again.

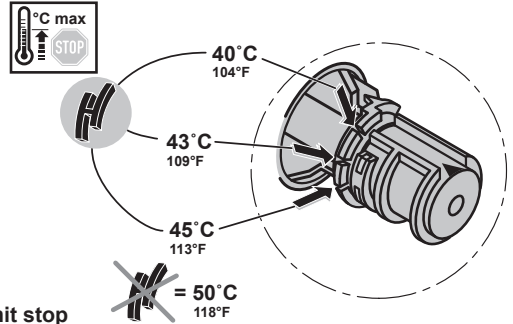

**Removal of limit stop
is not recommended**

8 CALIBRATION

In the event of the thermostatic cartridge requiring re-calibration the following procedure should be undertaken.

1. Remove the temperature control handle.
2. Slide out the red "U" piece (b) exposing temperature control mechanism (d).
3. Turn on the shower, position a thermometer in the running water and when the temperature settles, rotate the temperature control mechanism (d) until 40°C is achieved.
4. Reconnect the handle carrier (e) ensuring the arrow guide (c) is in line with (a) and refit the red "U" piece (b).
5. Reconnect the Handle.

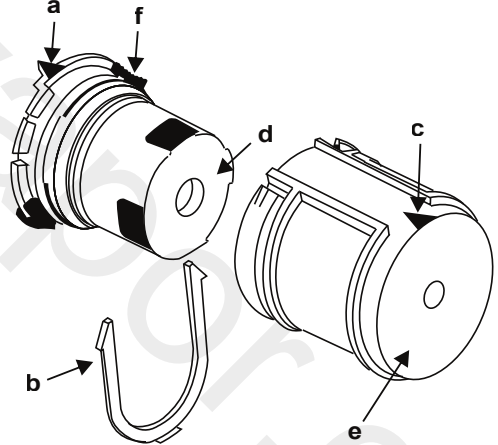

9 MAINTENANCE

The fitting of isolation valves and strainers is required as close as is practicable to the water supply inlets of the thermostatic valve. The thermostatic cartridge seldom fails and the possibility of blocked filters should be investigated before contemplating replacing it. Small particles of debris may still find their way past the strainers and onto the filter screens on the thermostatic cartridge. These should be cleaned and re-fitted. See section 10 on cartridge replacement.

9.1 COMMISSIONING & PERIODIC CHECKS.

The following procedures should be carried out after installation and every 12 months after to ensure that the valve is functioning correctly.

Check that:

1. The application of the thermostatic valve matches the approved designation.
2. The supply pressures are within the recommended range for the application.
3. The supply temperatures are within the permitted range for the application and comply with the guidance for prevention of Legionella.
4. The mixed temperature is as required for the application.

Record:

5. Each hot and cold supply. (Make a note of the measuring device used).
6. The mixed water temperature at the outlet device.

Isolate:

7. The cold supply to the mixing valve and record the mixed water temperature after about 5 seconds. The temperature should not exceed the value given in table (2) below.

Table 2 A guide to maximum temperature sets

Application	Mixed water temperature	Permitted maximum temperature rise during site testing
Shower	41°C	43°C

Note: 46°C is the maximum mixed water temperature from a bath tap. The maximum temperature takes account of the allowable temperature tolerances inherent thermostatic mixing valves and temperature loss in metal baths. **It is not a safe bathing temperature for adults and children.**

The British Burns Association recommends 37°C-37.5°C as a comfortable bathing temperature for Children. In premises covered by the Care Standards Act 2000, the maximum mixed water temperature is 43°C

9.2 FREQUENCY OF REGULAR SERVICING

The purpose of servicing regularly is to monitor the performance of changes in system and valve set up. This may require the need to adjust either the supply system or the valve. The product should be checked and tested 12 months after commissioning.

Firstly measure the water temperature at the shower outlet.

Carry out the cold water supply isolation test by isolating the cold water supply to the TMV, wait for 5 seconds if water is still flowing check that the temperature is below 46C. If there is no significant change to the set outlet temperature (+/-2°C or less change from the original settings) and the fail-safe shut off is functioning, then the valve is working correctly and no further service work is required.

Notes:

A residual flow is permitted during the commissioning or the annual verification (cold water supply isolation test), then this is acceptable providing the water temperature is no more than 2°C above the designated outlet temperature.

Temperature readings should be taken at the normal flow rate after allowing for the system to stabilize.

The sensing part of the thermometer probe must be fully submerged in the water that is to be tested.

Any TMV that has been adjusted or serviced must be re-commissioned and retested in accordance with the instructions detailed above.

10 THERMOSTATIC CARTRIDGE REPLACEMENT

This thermostatic cartridge is protected from water borne debris by mesh filter screens. These should be checked and cleaned before contemplating replacing the cartridge.

1. Turn off water
2. Prise out the index button.
3. Remove handle screw.
4. Pull off the temperature control handle.

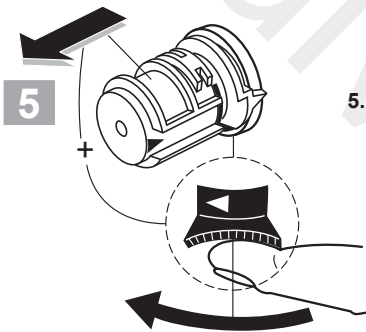
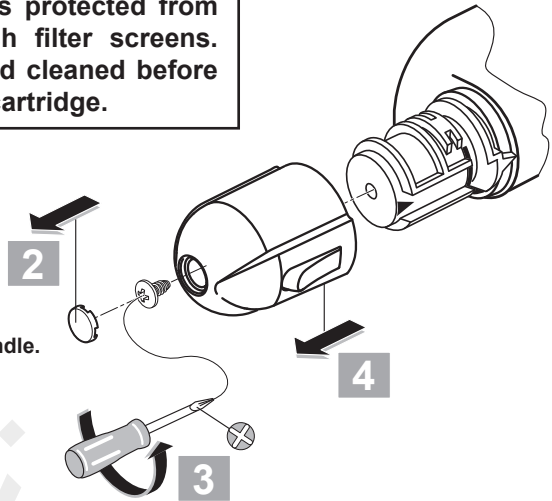

5. To remove the temperature handle carrier (grey plastic moulding), slide the black serrated lever clockwise and pull off. This will expose the thermostatic cartridge.

6. Unscrew cartridge with 24mm A/F spanner and replace if necessary.

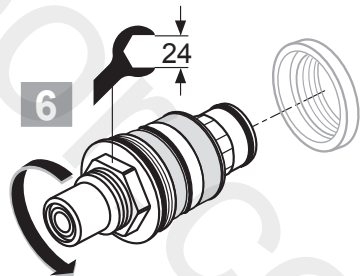

7. To clean the filter remove the o-rings shown
The screens will then slide off. When clean replace the screens then the o-rings which should be lightly greased with a WRAS approved silicone grease (e.g. Klueber Unisilikon GBU2).

8. Ensure parts are reassembled in the correct sequence.

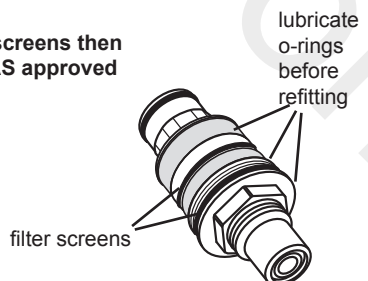

11 FLOW CARTRIDGE REPLACEMENT

1. Turn off water supplies
2. Prise out the index button.
3. Remove handle screw.
4. Pull off the flow control handle.
5. Pull off handle carriers.
6. Unscrew cartridge with 17mm A/F spanner and replace if necessary.
7. Ensure parts are reassembled in the correct sequence.

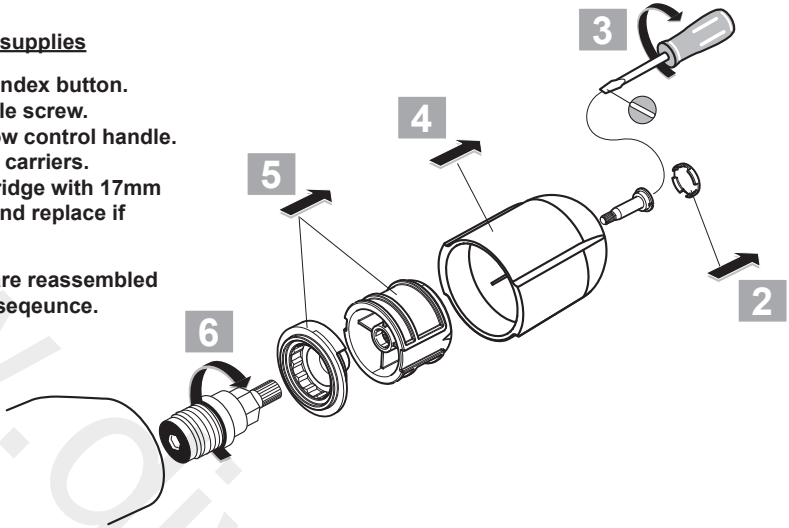

12 CHECK-VALVE REPLACEMENT

1. Turn off water supplies
2. Separate the shower valve from the wall bracket by undoing the captive nuts. See sect.5 step 8. Use 30mm A/F spanner.
3. Remove shower valve from wall, and keep sealing washers safe.
4. Using 10mm Allen key undo the retaining inserts. NOTE: THREADS ARE LEFT HAND. The captive nuts will also be released.
5. The check valves are housed inside the retaining inserts and can be pulled out gently and replaced if necessary. Note flow directional arrow marked on check valve body.
7. Ensure parts are reassembled in the correct sequence.

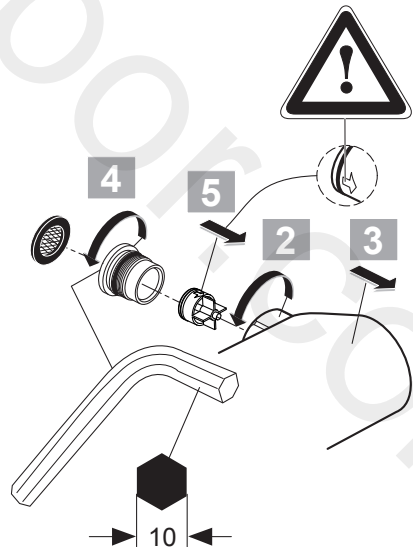

13 CLEANING

When cleaning the shower valve always use soap based cleaners. never use abrasive or scouring powders and never use cleaners containing alcohol, ammonia, nitric acid, phosphoric acid, organic solvents or disinfectants.

14 SPARE PARTS

- 1 A 962 361 LJ
- 3 A 962 998 NU
- 4 A 960 834 AA
- 5 F 960 922 AA
- 6 A 963 427 NU*
- 7 F 960 902 NU
- 8 A 963 432 NU*
- 9 A 961 214 NU
- 12 A 961 778 NU
- 14 A 961 810 NU
- 15 A 962 595 NU
- 16 B 960 242 AA
- 21 B 961 042 AA
- 22 A 963 651 NU

* Universal-Set

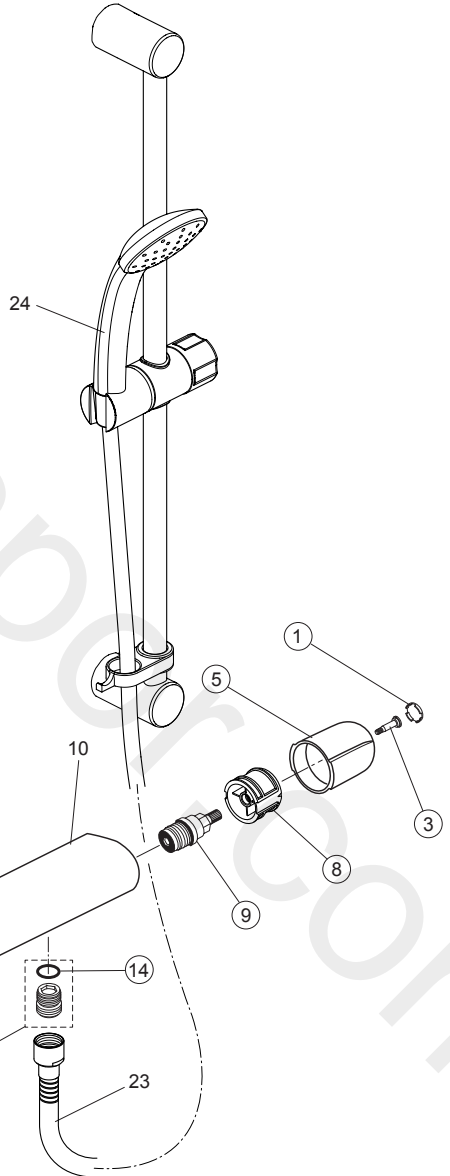

15 ISOLATING VALVES

Isolation valves (not supplied with this product) **MUST** be fitted to permit future maintenance.

These should be fitted as close as is practicable to the watersupply inlets of the thermostatic shower mixer.

Isolation valves should be installed in an easily accessible location

An in-line isolating service valve (shown here) can be purchased by contacting Fastpart. Spares code is: S9005AA



For more information on spare parts why not visit our spare website:
www.fastpart-spares.co.uk
or contact customer care



CUSTOMER CARE HELP LINE
0870 129 6085

CUSTOMER CARE FAX
01482 499611

E-MAIL
UKcustcare@idealstandard.com

Ideal Standard International NV
Corporate Village - Gent Building
Da Vincilaan 2
1935 Zaventem
Belgium

www.idealstandardinternational.com

Ideal Standard pursues a policy of continuing improvement in design and performance of its products.

This right is therefore reserved to vary specification without notice.

Ideal Standard is a division of
Ideal Standard (UK) Ltd

Ideal Standard,
The Bathroom Works, National Avenue
Kingston-upon-Hull, HU 4HS, England

0816 / A 866 593 40
+A 865 612
Made in Germany