

# AXOR

DE / Gebrauchsanleitung / Montageanleitung	02
FR / Mode d'emploi / Instructions de montage	02
EN / Instructions for use / assembly instructions	03
IT / Istruzioni per l'uso / Istruzioni per l'installazione	03
ES / Modo de empleo / Instrucciones de montaje	04
NL / Gebruiksaanwijzing / Handleiding	04
DK / Brugsanvisning / Monteringsvejledning	05
PT / Instruções para uso / Manual de instalação	05
PL / Instrukcja obsługi / Instrukcja montażu	06
CS / Návod k použití / Montážní návod	06
SK / Návod na použitie / Montážny návod	07
ZH / 用户手册 / 组装说明	07
RU / Руководство пользователя / Инструкция по монтажу	08
HU / Használati útmutató / Szerelési útmutató	08
FI / Käyttöohje / Asennusohje	09
SV / Bruksanvisning / Monteringsanvisning	09
LT / Vartotojo instrukcija / Montavimo instrukcijos	10
HR / Upute za uporabu / Uputstva za instalaciju	10
TR / Kullanım kılavuzu / Montaj kılavuzu	11
RO / Manual de utilizare / Instrucțiuni de montare	11
EL / Οδηγίες χρήσης / Οδηγία συναρμολόγησης	12
SL / Navodilo za uporabo / Navodila za montažo	12
ET / Kasutusjuhend / Paigaldusjuhend	13
LV / Lietošanas pamācība / Montāžas instrukcija	13
SR / Uputstvo za upotrebu / Uputstvo za montažu	14
NO / Bruksanvisning / Montasjeveiledning	14
BG / Инструкция за употреба / Ръководство за монтаж	15
SQ / Udhëzuesi i përdorimit / Udhëzime rreth montimit	15
AR / دليل الاستخدام / تعليمات التجميع	16

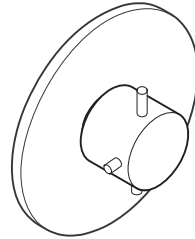

AXOR Starck  
10970000

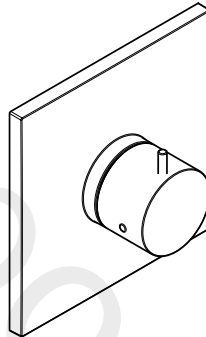

AXOR Starck X  
10974XXX

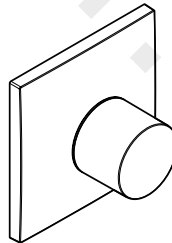

AXOR Massaud  
18770000

**⚠ SICHERHEITSHINWEISE**

- ⚠ Bei der Montage müssen zur Vermeidung von Quetsch- und Schnittverletzungen Handschuhe getragen werden.

**MONTAGEHINWEISE**

- / Vor der Montage muss das Produkt auf Transportschäden untersucht werden. Nach dem Einbau werden keine Transport- oder Oberflächenschäden anerkannt.
- / Die Leitungen und die Armatur müssen nach den gültigen Normen montiert, gespült und geprüft werden.
- / Die in den Ländern jeweils gültigen Installationsrichtlinien sind einzuhalten.

**SYMBOLERKLÄRUNG**

Kein essigsäurehaltiges Silikon verwenden!



MASSE (siehe Seite 17)



SERVICETEILE (siehe Seite 20)

XXX = Farbcodierung  
000 = Chrom  
820 = Brushed Nickel



REINIGUNG (siehe Seite 23)



PRÜFZEICHEN (siehe Seite 22)

**⚠ CONSIGNES DE SÉCURITÉ**

- ⚠ Lors du montage, porter des gants de protection pour éviter toute blessure par écrasement ou coupure.

**INSTRUCTIONS POUR LE MONTAGE**

- / Avant son montage, s'assurer que le produit n'a subi aucun dommage pendant le transport. Après le montage, tout dommage de transport ou de surface ne pourra pas être reconnu.
- / Les conduites et la robinetterie doivent être montés, rincés et contrôlés selon les normes en vigueur.
- / Les directives d'installation en vigueur dans le pays concerné doivent être respectées.

**DESCRIPTION DU SYMBOLE**

Ne pas utiliser de silicone contenant de l'acide acétique!



DIMENSIONS (voir pages 17)



PIÈCES DÉTACHÉES (voir pages 20)

XXX = Couleurs  
000 = Chromé  
820 = Brushed Nickel



NETTOYAGE (voir pages 23)



CLASSIFICATION ACOUSTIQUE ET DÉBIT (voir pages 22)

### ⚠ SAFETY NOTES

- ⚠ Gloves should be worn during installation to prevent crushing and cutting injuries.

### INSTALLATION INSTRUCTIONS

- / Prior to installation, inspect the product for transport damages. After it has been installed, no transport or surface damage will be honoured.
- / The pipes and the fixture must be installed, flushed and tested as per the applicable standards.
- / The plumbing codes applicable in the respective countries must be observed.

### ⚠ INDICAZIONI SULLA SICUREZZA

- ⚠ Durante il montaggio, per evitare ferite da schiacciamento e da taglio bisogna indossare guanti protettivi.

### ISTRUZIONI PER IL MONTAGGIO

- / Prima del montaggio è necessario controllare che non ci siano stati danni durante il trasporto. Una volta eseguito il montaggio, non verranno riconosciuti eventuali danni di trasporto o delle superfici.
- / Montare, lavare e controllare tubature e rubinetteria rispettando le norme correnti.
- / Vanno rispettate le direttive di installazione nazionali vigenti nel rispettivo paese.

### SYMBOL DESCRIPTION



Do not use silicone containing acetic acid!



DIMENSIONS (see page 17)



SPARE PARTS (see page 20)

XXX = Colors

000 = Chrome Plated

820 = Brushed Nickel



CLEANING (see page 23)



TEST CERTIFICATE (see page 22)

### DESCRIZIONE SIMBOLO



Non utilizzare silicone contenente acido acetico!



INGOMBRI (vedi pagg. 17)



PARTI DI RICAMBIO

(vedi pagg. 20)

XXX = Trattamento

000 = Cromato

820 = Brushed Nickel



PULITURA (vedi pagg. 23)



SEGNO DI VERIFICA

(vedi pagg. 22)



**△ INDICACIONES DE SEGURIDAD**

- △ Durante el montaje deben utilizarse guantes para evitar heridas por aplastamiento o corte.

**INDICACIONES PARA EL MONTAJE**

- / Antes del montaje se debe examinarse el producto contra daños de transporte. Después de la instalación no se reconoce ningún daño de transporte o de superficie.
- / Los conductos y la grifería deben montarse, lavarse y comprobarse según las normas vigentes.
- / Es obligatorio el cumplimiento de las directrices de instalación vigentes en el país respectivo.

**DESCRIPCIÓN DE SÍMBOLOS**

No utilizar silicona que contiene ácido acético!



DIMENSIONES (ver página 17)



REPUESTOS (ver página 20)

XXX = Acabados

000 = Cromado

820 = Brushed Nickel



LIMPIAR (ver página 23)



MARCA DE VERIFICACIÓN  
(ver página 22)

**△ VEILIGHEIDSINSTRUCTIES**

- △ Bij de montage moeten ter voorkoming van knel- en snijwonden handschoenen worden gedragen.

**MONTAGE-INSTRUCTIES**

- / Vóór de montage moet het product gecontroleerd worden op transportschade. Na de inbouw wordt geen transport- of oppervlakteschade meer aanvaard.
- / De leidingen en armaturen moeten gemonteerd, gespoeld en gecontroleerd worden volgens de geldige normen.
- / De in de overeenkomstige landen geldende installatierichtlijnen moeten nageleefd worden.

**SYMBOOLBESCHRIJVING**

Gebruik geen zuurhoudende siliconel!



MATEN (zie blz. 17)



SERVICE ONDERDELEN  
(zie blz. 20)

XXX = Kleuren

000 = Verchroomd

820 = Brushed Nickel



REINIGEN (zie blz. 23)



KEURMERK (zie blz. 22)

## ⚠ SIKKERHEDSANVISNINGER

- ⚠ Ved monteringen skal der bruges handsker for at undgå kvæstelser og snitsår.

## MONTERINGSANVISNINGER

- / Før monteringen skal produktet kontrolleres for transportskader. Efter monteringen godkendes transportskader eller skader på overfladen ikke længere.
- / Ledningerne og armaturerne skal monteres, skylles og kontrolleres iht. de gældende standarder.
- / Installationsbestemmelserne, der gælder i det enkelte land, skal overholdes.

## SYMBOLBESKRIVELSE

 Der må ikke benyttes eddikesyreholdig silikone!

 MÅLENE (se s. 17)

 RESERVEDELE (se s. 20)  
XXX = Overflade  
000 = Krom  
820 = Brushed Nickel

 RENGØRING (se s. 23)

 GODKENDELSE (se s. 22)

## ⚠ AVISOS DE SEGURANÇA

- ⚠ Durante a montagem devem ser utilizadas luvas de protecção, de modo a evitar ferimentos resultantes de entalamentos e de cortes.

## AVISOS DE MONTAGEM

- / Antes da montagem deve-se controlar o produto relativamente a danos de transporte. Após a montagem não são aceites quaisquer danos de transporte ou de superfície.
- / As tubagens e a torneira têm que ser montadas, enxaguadas e verificadas de acordo com as normas em vigor.
- / A prescrições de instalação válidas nos respetivos países devem ser respeitadas.

## DESCRIÇÃO DO SÍMBOLO

 Não utilizar silicone que contenha ácido acético!

 MEDIDAS (ver página 17)

 PEÇAS DE SUBSTITUIÇÃO (ver página 20)  
XXX = Acabamentos  
000 = Cromado  
820 = Brushed Nickel

 LIMPEZA (ver página 23)

 MARCA DE CONTROLO (ver página 22)

## ⚠ WSKAZÓWKI BEZPIECZEŃSTWA

- ⚠ Aby uniknąć zranień na skutek zgniecenia lub przecięcia, podczas montażu należy nosić rękawice ochronne.

## WSKAZÓWKI MONTAŻOWE

- / Przed montażem należy skontrolować produkt pod kątem szkód transportowych. Po montażu nie widać żadnych szkód transportowych ani szkód na powierzchni.
- / Przewody i armatura muszą być montowane, płukane i kontrolowane według obowiązujących norm.
- / Należy przestrzegać wytycznych instalacyjnych obowiązujących w danym kraju.

## OPIS SYMBOLU

 Nie stosować silikonów zawierających kwas octowy!

 WYMIARY (patrz strona 17)

 CZĘŚCI SERWISOWE (patrz strona 20)

XXX = Kody kolorów

000 = Chrom

820 = Brushed Nickel

 CZYSZCZENIE (patrz strona 23)

 ZNAK JAKOŚCI (patrz strona 22)

## ⚠ BEZPEČNOSTNÍ POKYNY

- ⚠ Pro zabránění řezným zraněním a pohmožděninám je nutné při montáži nosit rukavice.

## POKYNY K MONTÁŽI

- / Před montáží je třeba produkt zkontrolovat, zda nebyl při transportu poškozen. Po zabudování nebudou uznány žádné škody způsobené transportem nebo poškození povrchu.
- / Vedení a armatura musí být namontovány, propláchnuty a otestovány podle platných norem.
- / Je třeba dodržovat montážní pravidla platná v dané zemi.

## POPIS SYMBOLŮ

 Nepoužívat silikon s obsahem kyseliny octové!

 ROZMĚRY (viz strana 17)

 SERVISNÍ DÍLY (viz strana 20)

XXX = Kód povrchové úpravy

000 = Chrom

820 = Brushed Nickel

 ČIŠTĚNÍ (viz strana 23)

 ZKUŠEBNÍ ZNAČKA (viz strana 22)

## △ BEZPEČNOSTNÉ POKYNY

△ Pri montáži musíte nosiť rukavice, aby ste predišli pomliaždeninám a rezným poraneniam.

## POKYNY PRE MONTÁŽ

- / Pred montážou musíte produkt skontrolovať, či nebol počas transportu poškodený. Po zabudovaní nebudú uznané žiadne škody spôsobené transportom alebo poškodenia povrchu.
- / Ledningarna och blandaren måste monteras, spolans igenom och kontrolleras enligt de gällande normerna.
- / Je potrebné dodržiavať smernice o inštalácii, ktoré sú práve teraz platné v krajinách.

## POPIS SYMBOLOV



Nepoužívajte silikón s obsahom kyseliny octovej!



ROZMERY (viď strana 17)



SERVISNÉ DIELY (viď strana 20)

XXX = Farebné označenie  
000 = Chróm  
820 = Brushed Nickel



ČISTENIE (viď strana 23)



OSVEDČENIE O SKÚŠKE  
(viď strana 22)

## △ 安全技巧

△ 装配时为避免挤压和切割受伤，必须戴上手套。

## 安装提示

- / 安装前必须检查产品是否受到运输损害。安装后将不认可运输损害或表面损伤。
- / 管道和阀门必须根据通用标准进行安装、冲洗和检查。
- / 请遵守当地国家现行的安装规定。

## 符号说明



请勿使用含有乙酸的硅胶！



大小 (参见第 17 页)



备用零件 (参见第 20 页)

XXX = 颜色代码  
000 = 镀铬  
820 = Brushed Nickel



清洗 (参见第 23 页)



检验标记 (参见第 22 页)

## ⚠ УКАЗАНИЯ ПО ТЕХНИКЕ БЕЗОПАСНОСТИ

- ⚠ Во время монтажа следует надеть перчатки во избежание прищемления и порезов.

## УКАЗАНИЯ ПО МОНТАЖУ

- / Перед монтажом следует проверить изделие на предмет повреждений при перевозке. После монтажа претензии о возмещении ущерба за повреждения при перевозке или повреждения поверхностей не принимаются.
- / Трубы и арматура должны быть установлены, промыты и проверены в соответствии с действующими нормами.
- / Необходимо соблюдать требования по монтажу, действующие в соответствующих странах.

## ОПИСАНИЕ СИМВОЛОВ

 Не применяйте силикон, содержащий уксусную кислоту.

 РАЗМЕРЫ (см. стр. 17)

 КОМПЛЕКТ (см. стр. 20)  
XXX = Цветная кодировка  
000 = Хром  
820 = Brushed Nickel

 ОЧИСТКА (см. стр. 23)

 ЗНАК ТЕХНИЧЕСКОГО КОНТРОЛЯ (см. стр. 22)

## ⚠ BIZTONSÁGI UTASÍTÁSOK

- ⚠ A szerelésnél a zúzódások és vágási sérülések elkerülése érdekében kesztyűt kell viselni.

## SZERELÉSI UTASÍTÁSOK

- / A szerelés előtt ellenőrizni kell, hogy a terméknek nincs-e szállítási sérülése. Beépítés után a szállítási vagy felületi sérüléseket nem ismerik el.
- / A vezetékeket és a csaptelepet az érvényes szabványoknak megfelelően kell felszerelni, öblíteni és ellenőrizni
- / Az egyes országokban érvényes installációs irányelveket be kell tartani.

## SZIMBÓLUMOK LEÍRÁSA

 Ne használjon ecetsavtartalmú szilikont!

 MÉRETEK (lásd a oldalon 17)

 TARTOZÉKOK (lásd a oldalon 20)  
XXX = Színkódolás  
000 = Króm  
820 = Brushed Nickel

 TISZTÍTÁS (lásd a oldalon 23)

 VIZSGAJEL (lásd a oldalon 22)



## △ TURVALLISUUSOHJEET

- △ Asennuksessa on käytettävä käsineitä puristumien ja viiltojen aiheuttamien tapaturmien estämiseksi.

## ASENNUSOHJEET

- / Ennen asennusta on tarkastettava tuotteen mahdolliset kuljetusvahingot. Asennuksen jälkeen kuljetus- ja pintavaurioita ei hyväksytä.
- / Putket ja hana on asennettava, huuhdeltava ja tarkastettava voimassa olevien standardien mukaisesti.
- / Jokaisessa maassa on noudatettava siellä päteviä asennusohjeita.

## MERKIN KUVAUS



Älä käytä etikkahappopitoista silikonial



MITAT (katso sivu 17)



VARAOSAT (katso sivu 20)

XXX = Värikooodaus  
000 = Kromi  
820 = Brushed Nickel



PUHDISTUS (katso sivu 23)



KOESTUSMERKKI (katso sivu 22)

## △ SÄKERHETSANVISNINGAR

- △ Handskar ska bäras under monteringsarbetet så att man kan undvika kläm- och skärskadorgen werden.

## MONTERINGSANVISNINGAR

- / Det måste undersökas om produkten har transportskador innan den monteras. Efter monteringen accepteras inga transport- eller ytskiktskador.
- / Ledningarna och blandaren måste monteras, spolas igenom och kontrolleras enligt de gällande normerna.
- / De installationsriktlinjer som gäller i länderna ska följas.

## SYMBOLFÖRKLARING



Använd inte silikon som innehåller ättiksyra!



MÄTTEN (se sidan 17)



RESERVDELAR (se sidan 20)

XXX = Färgkodning  
000 = Krom  
820 = Brushed Nickel



RENGÖRING (se sidan 23)



TESTSIGILL (se sidan 22)



## ⚠ SAUGUMO TECHNIKOS NURODYMAI

- ⚠ Apsaugai nuo užspaudimo ir įsijovimo montavimo metu mūvėkite pirštines.

## MONTAVIMO INSTRUKCIJA

- / Prieš montuojant būtina patikrinti, ar gaminyje nebuvo pažeistas transportavimo metu. Sumontavus pretenzijos dėl transportavimo ir paviršiaus pažeidimų nepriimamos.
- / Vamzdžiai ir sujungimai turi būti montuojami, plaunami ir tikrinami pagal galiojančias normas.
- / Laikykitės atitinkamoje šalyje galiojančių direktyvų dėl įrengimo.

## SIMBOLIO APRAŠYMAS

-  Nenaudokite silikono, kurio sudėtyje yra acto rūgšties!
-  IŠMATAVIMAI (žr. psl. 17)
-  ATSARGINĖS DALYS (žr. psl. 20)  
XXX = Spalvos  
000 = Chrom  
820 = Brushed Nickel
-  VALYMAS (žr. psl. 23)
-  BANDYMO PAŽYMA (žr. psl. 22)





## ⚠ SIGURNOSNE UPUTE

- ⚠ Prilikom montaže se radi sprječavanja prignječenja i posjekotina moraju nositi rukavice.

## UPUTE ZA MONTAŽU

- / Prije montaže mora se provjeriti je li proizvod oštećen prilikom transporta. Nakon ugradnje se ne priznaju nikakve reklamacije koje se odnose na površinska i transportna oštećenja.
- / Cijevi i armatura moraju biti postavljeni, isprani i testirani prema važećim normama.
- / Obvezno se moraju uvažiti propisi o instalacijama koji vrijede u dotičnoj zemlji.

## OPIS SIMBOLA

-  Nemojte koristiti silikon koji sadrži octenu kiselinu!
-  MJERE (pogledaj stranicu 17)
-  REZERVNI DJELOVI (pogledaj stranicu 20)  
XXX = Boje  
000 = Krom  
820 = Brushed Nickel
-  ČIŠĆENJE (pogledaj stranicu 23)
-  OZNAKA TESTIRANJA (pogledaj stranicu 22)



## ⚠ GÜVENLİK UYARILARI

- ⚠ Montaj esnasında ezilme ve kesilme gibi yaralanmaları önlemek için eldiven kullanılmalıdır.

## MONTAJ AÇIKLAMALARI

- / Montaj işleminden önce ürün nakliye hasarları yönünden kontrol edilmelidir. Montaj işleminden sonra nakliye veya yüzey hasarları için sorumluluk üstlenilmemektedir.
- / Boruların ve armatürün montajı, yıkanması ve kontrolü geçerli normlara göre yapılmalıdır.
- / Ülkelerde geçerli kurulum yönetmeliklerine riayet edilmelidir.



## ⚠ INSTRUCȚIUNI DE SIGURANȚĂ

- ⚠ La montare utilizați mănuși pentru evitarea contuziunilor și tăierii mâinilor.

## INSTRUCȚIUNI DE MONTARE

- / Înainte de instalare verificați, dacă produsul prezintă deteriorări de transport. După instalare garanția nu acoperă deteriorările de transport și cele de suprafață.
- / Conductele și bateriile trebuie montate, spălate și verificate conform normelor în vigoare.
- / Respectați reglementările referitoare la instalare valabile în țara respectivă.



## SİMGE AÇIKLAMASI

-  Asetik asit içeren silikon kullanmayın!
-  ÖLÇÜLERİ (bakınız sayfa 17)
-  YEDEK PARÇALAR (bakınız sayfa 20)  
XXX = Renkler  
000 = Krom  
820 = Brushed Nickel

-  TEMİZLEME (bakınız sayfa 23)

-  KONTROL İŞARETİ (bakınız sayfa 22)

## DESCRIEREA SIMBOLURILOR

-  Nu utilizați silicon cu conținut de acid acetic!
-  DIMENSIUNI (vezi pag. 17)
-  PIESE DE SCHIMB (vezi pag. 20)  
XXX = Coduri de culori  
000 = Crom  
820 = Brushed Nickel

-  CURĂȚARE (vezi pag. 23)

-  CERTIFICAT DE TESTARE (vezi pag. 22)

**⚠ ΥΠΟΔΕΙΞΕΙΣ ΑΣΦΑΛΕΙΑΣ**

⚠ Για να αποφύγετε τραυματισμούς κατά τη συναρμολόγηση πρέπει να φοράτε γάντια.

**ΟΔΗΓΙΕΣ ΣΥΝΑΡΜΟΛΟΓΗΣΗΣ**

- / Πριν τη συναρμολόγηση πρέπει να εξεταστεί το προϊόν για ζημιές μεταφοράς. Μετά την εγκατάσταση δεν αναγνωρίζονται ζημιές από τη μεταφορά ή επιφανειακές ζημιές.
- / Οι σωλήνες και η μπαταρία πρέπει να τοποθετηθούν σύμφωνα με τα ισχύοντα πρότυπα, να τεθούν υπό πίεση και να δοκιμαστούν.
- / Θα πρέπει να τηρούνται οι οδηγίες εγκατάστασης που ισχύουν σε κάθε κράτος.

**ΠΕΡΙΓΡΑΦΗ ΣΥΜΒΟΛΩΝ**

Μην χρησιμοποιείτε σιλικόνη που περιέχει οξικό οξύ!



ΔΙΑΣΤΑΣΕΙΣ (βλ. Σελίδα 17)



ΑΝΤΑΛΛΑΚΤΙΚΑ (βλ. Σελίδα 20)

XXX = Χρώματα

000 = Επιχρωμωμένο

820 = Brushed Nickel



ΚΑΘΑΡΙΣΜΟΣ (βλ. Σελίδα 23)



ΣΗΜΑ ΕΛΕΓΧΟΥ (βλ. Σελίδα 22)

**⚠ VARNOSTNA OPOZORILA**

⚠ Pri montaži je treba nositi rokavice, da se preprečijo poškodbe zaradi zmečkanja ali urezov.

**NAVODILA ZA MONTAŽO**

- / Pred montažo je treba izdelek preveriti glede morebitnih transportnih poškodb. Po vgradnji transportne ali površinske poškodbe ne bodo več priznane.
- / Cevi in armaturo je treba montirati, izprati in preveriti po veljavnih standardih.
- / Upoštevati je treba pravilnike o inštalacijah, ki veljajo v posamezni državi.

**OPIS SIMBOLA**

Ne smete uporabiti silikona, ki vsebuje očetno kislino!



MERE (glejte stran 17)



REZERVNI DELI (glejte stran 20)

XXX = Barve

000 = Krom

820 = Brushed Nickel



ČIŠČENJE (glejte stran 23)



PRESKUSNI ZNAK (glejte stran 22)

### △ OHUTUSJUHISED

- △ Kandke paigaldamisel muljumis- ja löikevigastuste vältimiseks kindaid.

### PAIGALDAMISJUHISED

- / Enne paigaldamist tuleb toodet kontrollida transportikahjustuste osas. Pärast paigaldamist ei tunnustata enam transporti- või pinnakahjustuste kaebuseid.
- / Voolikute ja segisti paigaldamisel, loputamisel ja kontrollimisel tuleb lähtuda kehtivatest normatiividest
- / Vastavas riigis kehtivaid paigalduseeskirju tuleb järgida.

### △ DROŠĪBAS NORĀDES

- △ Montāžas laikā, lai izvairītos no saspiedumiem un iegriezumiem, nepieciešams nēsāt cimdus.

### NORĀDĪJUMI MONTĀŽAI

- / Pirms montāžas nepieciešams pārbaudīt, vai produktam transportēšanas laikā nav radušies bojājumi. Pēc iebūvēšanas bojājumi, kas radušies transportēšanas laikā, vai virsmas bojājumi netiek atzīti.
- / Cauruļvadi un armatūra ir jāuzstāda, jāizskalo un jāpārbauda saskaņā ar spēkā esošajiem standartiem.
- / Jāievēro attiecīgās valstis spēkā esošās montāžas prasības.

### SŪMBOLITE KIRJELDUS



Ärge kasutage äädikhapet sisaldavat silikooni!



MÕÕTUDE (vt lk 17)



VARUOSAD (vt lk 20)

XXX = Värvid  
000 = Kroom  
820 = Brushed Nickel



PUHASTAMINE (vt lk 23)



KONTROLLSERTIFIKAAT (vt lk 22)

### SIMBOLU NOZĪME



Neizmantoj silikonu, kas satur etiķskābi!



IZMĒRUS (skat. lpp. 17)



REZERVES DAĻAS (skat. lpp. 20)

XXX = Krāsu kodi  
000 = Hroma  
820 = Brushed Nickel



TĪRĪŠANA (skat. lpp. 23)



PĀRBAUDES ZĪME (skat. lpp. 22)



## ⚠ SIGURNOSNE NAPOMENE

- ⚠ Prilikom montaže se radi sprečavanja prignječenja i posekotine moraju nositi rukavice.

## INSTRUKCIJE ZA MONTAŽU

- / Pre montaže se mora proveriti da li je proizvod oštećen pri transportu. Nakon ugradnje se ne priznaju nikakve reklamacije koje se odnose na površinska i transportna oštećenja.
- / Vodovi i armatura moraju biti postavljeni, isprani i testirani prema važećim normama.
- / Treba se pridržavati propisa koji u određenim zemljama važe za instalacije.

## OPIS SIMBOLA

 Nemojte koristiti silikon koji sadrži sirćetnu kiselinu!

 MERE (vidi stranu 17)

 REZERVNI DELOVI (vidi stranu 20)  
 XXX = Oznake boja  
 000 = Hrom  
 820 = Brushed Nickel

 ČIŠĆENJE (vidi stranu 23)

 ISPITNI ZNAK (vidi stranu 22)

## ⚠ SIKKERHETSHENVISNINGER

- ⚠ Bruk hansker under montasjen for å unngå klem- og kuttskader.

## MONTAGEHENVISNINGER

- / Før montasjen skal produktet sjekkes for transportskader. Etter monteringen aksepteres ikke noen transport- eller overflateskader.
- / Ledningene og armaturen skal monteres, spyles og sjekkes iht. de gyldige normer.
- / Gjeldende retningslinjer for rørleggerarbeid i de enkelte land skal følges.

## SYMBOLBESKRIVELSE

 Ikke bruk silikon som inneholder eddiksyre!

 MÅL (se side 17)

 SERVICEDELER (se side 20)  
 XXX = Fargekode  
 000 = Krom  
 820 = Brushed Nickel

 RENGJØRING (se side 23)

 PRØVEMERKE (se side 22)

## ⚠ УКАЗАНИЯ ЗА БЕЗОПАСНОСТ

- ⚠ При монтажа трябва да се носят ръкавици, за да се избегнат наранявания поради притискане или порязване.

## УКАЗАНИЯ ЗА МОНТАЖ

- / Преди монтажа продуктът трябва да се провери за транспортни щети. След монтажа не се признават транспортни или повърхностни щети.
- / Тръбопроводите и арматурата трябва да се монтират, промият и проверят в съответствие с валидните норми.
- / Трябва да бъдат спазвани валидните в съответните страни предписания за инсталиране.

## ОПИСАНИЕ НА СИМВОЛИТЕ

 Не използвайте силикон, съдържащ оцветна киселина!

 РАЗМЕРИ (вижте стр. 17)

 СЕРВИЗНИ ЧАСТИ (вижте стр. 20)  
 XXX = Цветово кодиране  
 000 = Хром  
 820 = Brushed Nickel

 ПОЧИСТВАНЕ (вижте стр. 23)

 КОНТРОЛЕН ЗНАК (вижте стр. 22)

## ⚠ UDHËZIME SIGURIE

- ⚠ Për të evituar lëndimet e pickimeve ose të prerjeve gjatë procesit të montimit duhet që të vishni doreza.

## UDHËZIME PËR MONTIMIN

- / Përpara montimit duhet që produkti të kontrollohet për dëmtime nga transporti. Pas instalimit nuk do të njihet asnjë dëmtim nga transporti ose dëmtim i sipërfaqes.
- / Tubacionet dhe rubinetet duhet që të montohen, të shpëlahen dhe të kontrollohen sipas standardeve në fuqi
- / Duhet të respektohen linjat udhëzuese të instalimit, të vlefshme për vendet respektive.

## PËRSHKRIMI I SIMBOLIT

 Mos përdorni silikon që në përbërje ka acid acetik.

 PËRMASAT (shih faqen 17)

 PJESËT E SERVISIT (shih faqen 20)  
 XXX = Kodimi me anë të ngjyrave  
 000 = Krom  
 820 = Brushed Nickel

 PASTRIMI (shih faqen 23)

 SHENJA E KONTROLLIT (shih faqen 22)



### ⚠ تنبيهات الأمان

⚠ يجب إرتداء قفازات لليد أثناء التركيب لتجنب حدوث أخطار الإنحشار أو الجروح.

### تعليمات التركيب

- / قبل القيام بعملية التركيب، يجب فحص المنتج للتأكد من خلوه من أية تلفيات ناتجة عن النقل. بعد القيام بعملية التركيب، لن يتم الاعتراف بوجود أية تلفيات سطحية أو تلفيات ناتجة عن عملية النقل.
- / يجب تركيب وغسيل واختبار التوصيلات وخلطات المياه طبقاً للمعايير السارية.
- / يجب مراعاة القواعد الخاصة بالتركيب وأعمال السباكة وفقاً للوائح الخاصة بكل بلد.

### وصف الرمز

هام! لا تستخدم السليكون الذي يحتوي على أحماض! 

أبعاد (راجع صفحة 17) 

قطع الغيار (راجع صفحة 20) 

XXX = الألوان

000 = كروم

Brushed Nickel = 820

التنظيف (راجع صفحة 23) 

شهادة اختبار (راجع صفحة 22) 

التركيب (راجع صفحة 18) 



AXOR Starck  
10970000

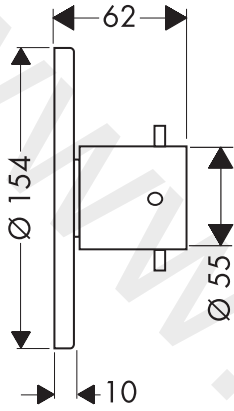

AXOR Starck X  
10974XXX

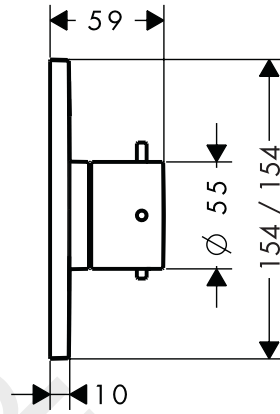

AXOR Massaud  
18770000

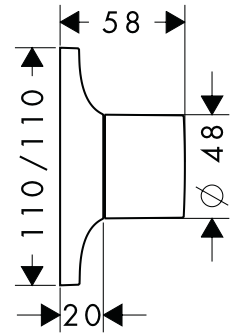



DN20 (3/4")  
16970180

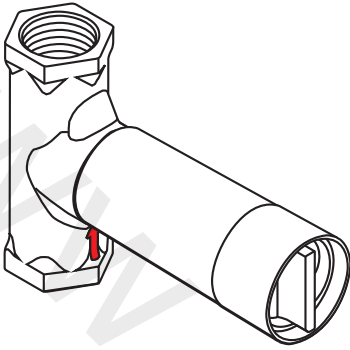

DN15 (1/2")  
16973180/16974180

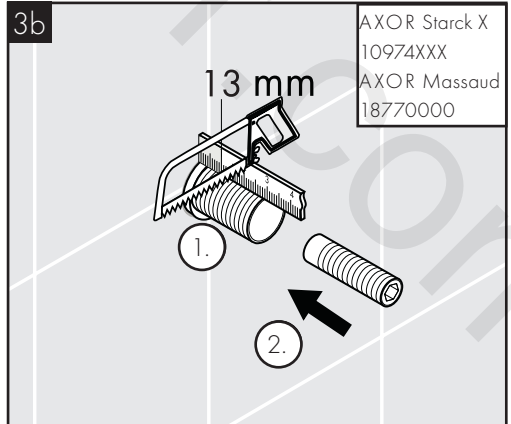
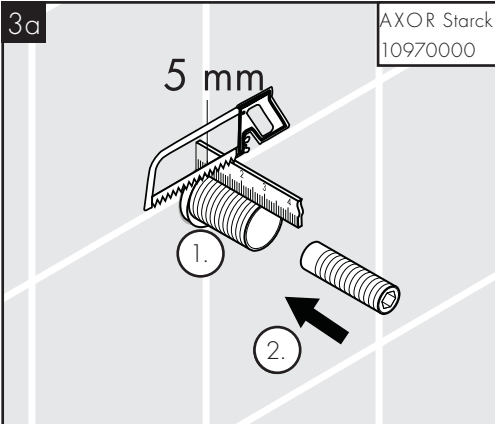
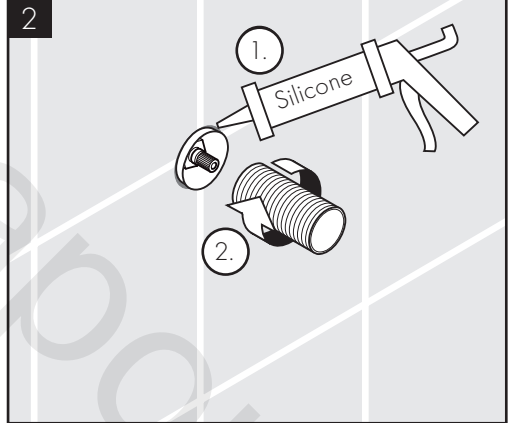
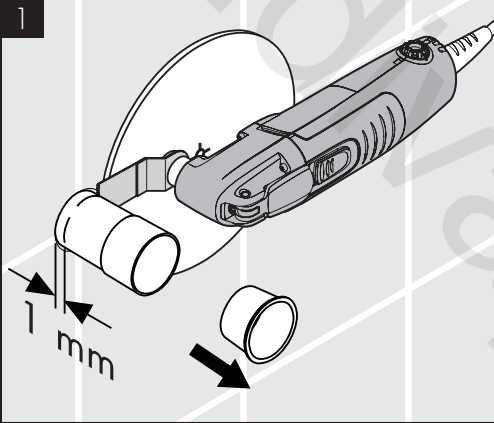
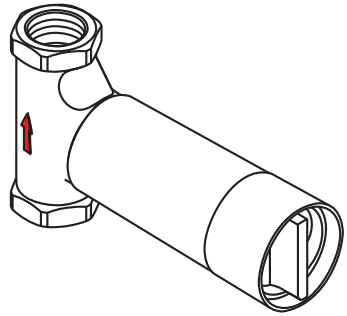



4a

 AXOR Starck  
10970000

15 mm

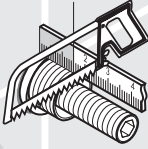

4b

 AXOR Starck X  
10974XXX  
AXOR Massaud  
18770000

20 mm

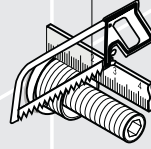

5a

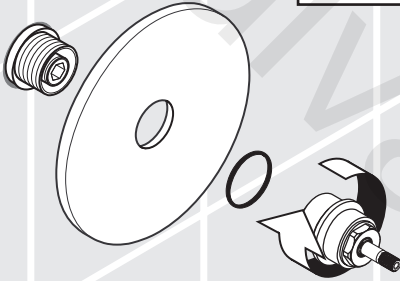
 AXOR Starck  
10970000

5b

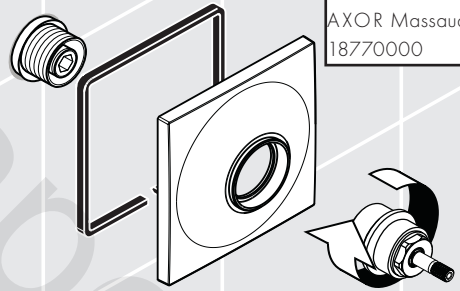
 AXOR Starck X  
10974XXX  
AXOR Massaud  
18770000

6a

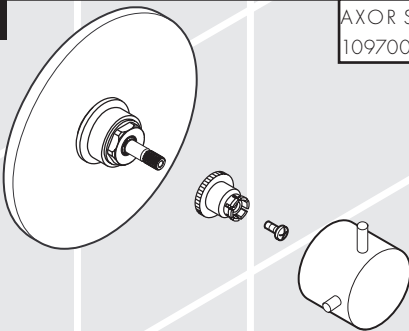
 AXOR Starck  
10970000

6b

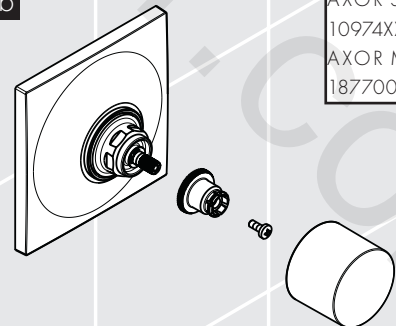
 AXOR Starck X  
10974XXX  
AXOR Massaud  
18770000



AXOR Starck  
10970000

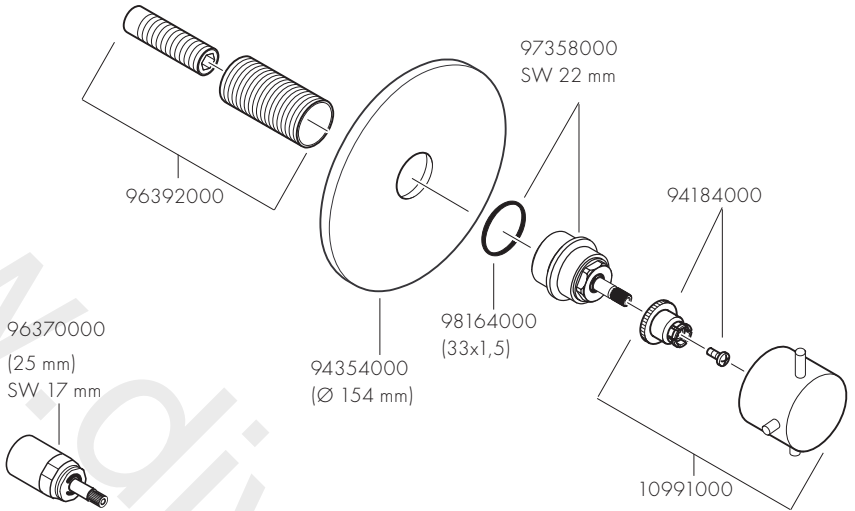

AXOR Starck X  
10974XXX

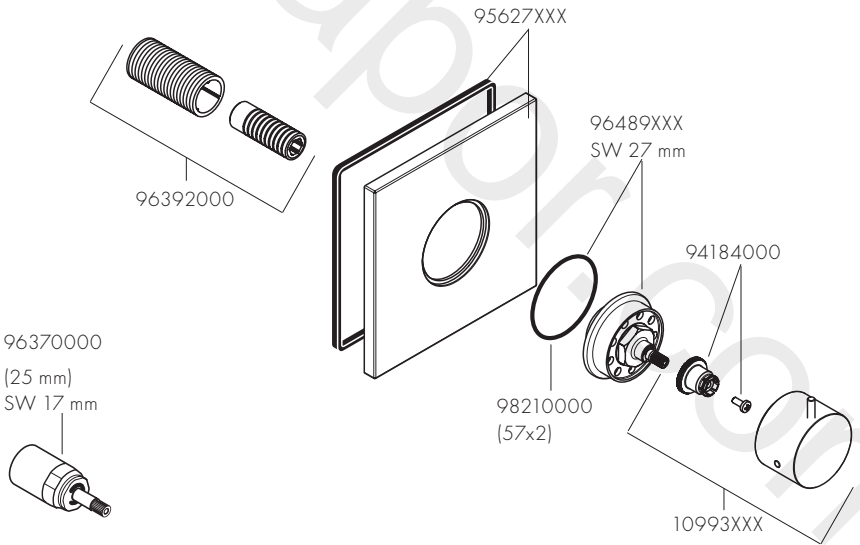



AXOR Massaud  
18770000

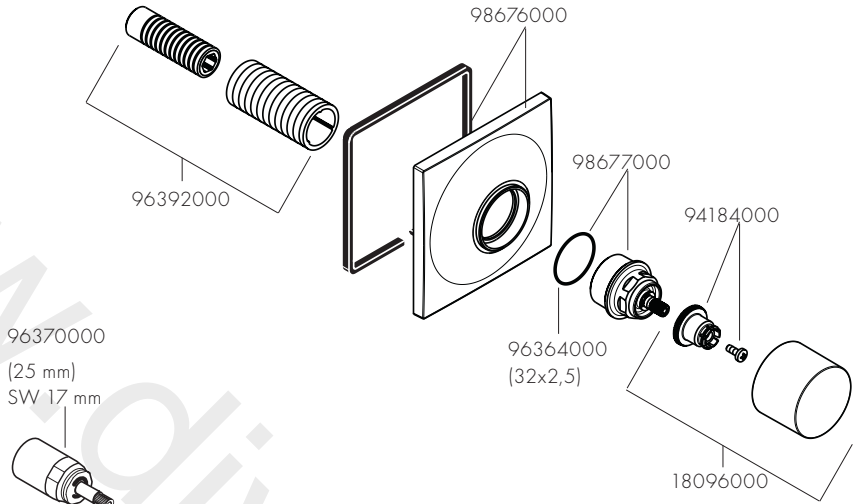



	P-IX	DVGW	MCA	SVGW	WRAS	KIWA	NF	ACS	ETA
10970000				X	X				
10974XXX					X				
18770000				X	X				

www.divapor.com



- DE / Reinigungsempfehlung / Garantie / Kontakt  
 FR / Recommandation pour le nettoyage / Garanties / Contact  
 EN / Cleaning recommendation / Warranty / Contact  
 IT / Raccomandazione di pulizia / Garanzia / Contatto  
 ES / Recomendaciones para la limpieza / Garantía / Contacto  
 NL / Aanbevelingen inzake reiniging / Garantie / Contact  
 DK / Rensning, anbefaling / Garanti / Kontakt  
 PT / Recomendações de limpeza / Garantia / Contacto  
 PL / Zalecenie dotyczące pielęgnacji / Gwarancja / Kontakt  
 CS / Doporučení k čištění / Záruka / Kontakt  
 SK / Odporúčania pre čistenie / Záruka / Kontakt  
 ZH / 清洁指南 / 担保 / 接触  
 RU / Рекомендации по очистке / Гарантия / Контакты  
 HU / Tisztítási tanácsok / Garancia / érintkezés  
 FI / Puhdistussuositus / Takuu / Kosketus  
 SV / Rengöringsrekommendationer / Garanti / Contacto  
 LT / Valymo rekomendacijos / Garantija / Kontaktai  
 HR / Preporuke za čišćenje / Garancija / Kontakt  
 TR / Temizleme önerisi / Garanti / Temas  
 RO / Recomandări pentru curățare / Garanție / Contact  
 EL / Σύσταση καθαρισμού / Εγγύηση / επαφή  
 SL / Priporočilo za čiščenje / Garancija / Kontakt  
 ET / Puhastussuovitused / Garantii / Kontakt  
 LV / Tīrīšanas ieteikumi / Garantija / Kontakti  
 SR / Preporuke za čišćenje / Garancija / Kontakt  
 NO / Anbefaling for rengjøring / Garanti / Kontakt  
 BG / Препоръка за почистване / Гаранция / Контакт  
 SQ / Këshilla rreth pastrimit / Garancia / Kontakt  
 KO / 세정시 권장사항 / 품질보증 / 접촉  
 AR / توصيات التنظيف / الضمان (الولايات المتحدة الأمريكية) / اتصال



[www.axor-design.com/  
cleaning-recommendation](http://www.axor-design.com/cleaning-recommendation)

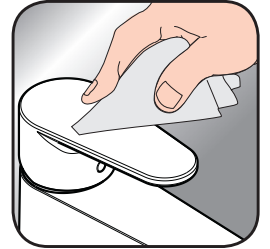

[www.axor-design.com/  
cleaning-recommendation](http://www.axor-design.com/cleaning-recommendation)



[www.axor-design.com/  
cleaning-recommendation](http://www.axor-design.com/cleaning-recommendation)



[www.axor-design.com/  
cleaning-recommendation](http://www.axor-design.com/cleaning-recommendation)

# AXOR

www.divapor.com

AXOR / Hansgrohe SE  
AustraÙe 5-9  
77761 Schiltach  
Deutschland

info@axor-design.com  
axor-design.com

07/2018  
9.09265.07