

AXOR

DE / Montageanleitung	02
FR / Instructions de montage	02
EN / assembly instructions	03
IT / Istruzioni per Installazione	03
ES / Instrucciones de montaje	04
NL / Handleiding	04
DK / Monteringsvejledning	05
PT / Manual de Instalação	05
PL / Instrukcja montażu	06
CS / Montážní návod	06
SK / Montážny návod	07
ZH / 组装说明	07
RU / Инструкция по монтажу	08
HU / Szerelési útmutató	08
FI / Asennusohje	09
SV / Monteringsanvisning	09
LT / Montavimo instrukcijos	10
HR / Uputstva za instalaciju	10
TR / Montaj kılavuzu	11
RO / Instrucțiuni de montare	11
EL / Οδηγία συναρμολόγησης	12
SL / Navodila za montažo	12
ET / Paigaldusjuhend	13
LV / Montāžas instrukcija	13
SR / Uputstvo za montažu	14
NO / Montasjeveiledning	14
BG / Ръководство за монтаж	15
SQ / Udhëzime rreth montimit	15
AR / عميلنا تاميلع	16

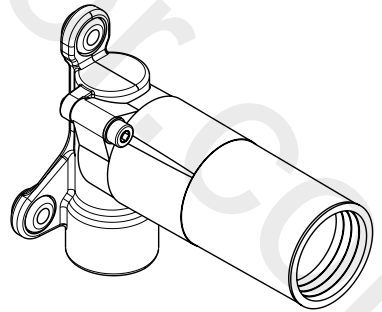

AXOR Massaud
18471180

INSTALLATION

⚠ SICHERHEITSHINWEISE

- ⚠ Bei der Montage müssen zur Vermeidung von Quetsch- und Schnittverletzungen Handschuhe getragen werden.
- ⚠ Große Druckunterschiede zwischen den Kalt- und Warmwasseranschlüssen müssen ausgeglichen werden.

MONTAGEHINWEISE

- / Vor der Montage muss das Produkt auf Transportschäden untersucht werden. Nach dem Einbau werden keine Transport- oder Oberflächenschäden anerkannt.
- / Die Leitungen und die Armatur müssen nach den gültigen Normen montiert, gespült und geprüft werden.
- / Die in den Ländern jeweils gültigen Installationsrichtlinien sind einzuhalten.

SYMBOLERKLÄRUNG

Kein essigsäurehaltiges Silikon verwenden!



Wandverstärkung notwendig



MASSE (siehe Seite 17)

SONDERZUBEHÖR (nicht im Lieferumfang enthalten)

/ Dichtmanschette #96492000 (siehe Seite 22)
Die Dichtmanschette darf nicht heiß verklebt werden.

SERVICETEILE (siehe Seite 22)



FERTIGSET (siehe Seite 21)



PRÜFZEICHEN (siehe Seite 17)

⚠ CONSIGNES DE SÉCURITÉ

- ⚠ Lors du montage, porter des gants de protection pour éviter toute blessure par écrasement ou coupure.
- ⚠ Il est conseillé d'équilibrer les pressions de l'eau chaude et froide.

INSTRUCTIONS POUR LE MONTAGE

- / Avant son montage, s'assurer que le produit n'a subi aucun dommage pendant le transport. Après le montage, tout dommage de transport ou de surface ne pourra pas être reconnu.
- / Les conduites et la robinetterie doivent être montés, rincés et contrôlés selon les normes en vigueur.
- / Les directives d'installation en vigueur dans le pays concerné doivent être respectées.

DESCRIPTION DU SYMBOLE

Ne pas utiliser de silicone contenant de l'acide acétique!



Renforcement de la paroi nécessaire



DIMENSIONS (voir pages 17)

ACCESSOIRES EN OPTION (ne fait pas partie de la fourniture)



/ lamelle #96492000 (voir pages 22) La manchette étanche ne doit pas être collée à chaud.



PIÈCES DÉTACHÉES (voir pages 22)



SET DE FINITION (voir pages 21)



CLASSIFICATION ACOUSTIQUE ET DÉBIT (voir pages 17)

⚠ SAFETY NOTES

- ⚠ Gloves should be worn during installation to prevent crushing and cutting injuries.
- ⚠ The hot and cold supplies must be of equal pressures.

INSTALLATION INSTRUCTIONS

- / Prior to installation, inspect the product for transport damages. After it has been installed, no transport or surface damage will be honoured.
- / The pipes and the fixture must be installed, flushed and tested as per the applicable standards.
- / The plumbing codes applicable in the respective countries must be observed.







⚠ INDICAZIONI SULLA SICUREZZA

- ⚠ Durante il montaggio, per evitare ferite da schiacciamento e da taglio bisogna indossare guanti protettivi.
- ⚠ Attenzione! Compensare le differenze di pressione tra i collegamenti dell'acqua fredda e dell'acqua calda.





ISTRUZIONI PER IL MONTAGGIO

- / Prima del montaggio è necessario controllare che non ci siano stati danni durante il trasporto. Una volta eseguito il montaggio, non verranno riconosciuti eventuali danni di trasporto o delle superfici.
- / Montare, lavare e controllare tubature e rubinetteria rispettando le norme correnti.
- / Vanno rispettate le direttive di installazione nazionali vigenti nel rispettivo paese.

SYMBOL DESCRIPTION

-  Do not use silicone containing acetic acid!
-  Area for required wall reinforcement
-  DIMENSIONS (see page 17)
-  SPECIAL ACCESSORIES (order as an extra)
/ sealing foil #96492000 (see page 22) The gasket is not suitable for hot glue.
-  SPARE PARTS (see page 22)
-  FINISH SET (see page 21)
-  TEST CERTIFICATE (see page 17)

DESCRIZIONE SIMBOLO

-  Non utilizzare silicone contenente acido acetico!
-  Campo rinforzo necessario della parete
-  INGOMBRI (vedi pagg. 17)
-  ACCESSORI SPECIALI (non contenuto nel volume di fornitura)
/ guarnizione a flangia #96492000 (vedi pagg. 22) Il manicotto di tenuta non deve essere incollato a caldo.
-  PARTI DI RICAMBIO (vedi pagg. 22)
-  SET ESTERNO (vedi pagg. 21)
-  SEGNO DI VERIFICA (vedi pagg. 17)

INDICACIONES DE SEGURIDAD

- ⚠ Durante el montaje deben utilizarse guantes para evitar heridas por aplastamiento o corte.
- ⚠ Grandes diferencias de presión en servicio entre agua fría y agua caliente deben equilibrarse.

INDICACIONES PARA EL MONTAJE

- / Antes del montaje se debe examinarse el producto contra daños de transporte. Después de la instalación no se reconoce ningún daño de transporte o de superficie.
- / Los conductos y la grifería deben montarse, lavarse y comprobarse según las normas vigentes.
- / Es obligatorio el cumplimiento de las directrices de instalación vigentes en el país respectivo.

DESCRIPCIÓN DE SÍMBOLOS

No utilizar silicona que contiene ácido acético!



Área refuerzo necesario de la pared



DIMENSIONES (ver página 17)

OPCIONAL (no incluido en el suministro)



/ Tira impermeabilizante #96492000 (ver página 22) El manguito de estanqueidad no debe pegarse en caliente.



REPUESTOS (ver página 22)



EMBELLECEDOR EXTERIOR (ver página 21)



MARCA DE VERIFICACIÓN (ver página 17)

VEILIGHEIDSINSTRUCTIES

- ⚠ Bij de montage moeten ter voorkoming van knel- en snijwonden handschoenen worden gedragen.
- ⚠ Grote drukverschillen tussen de koud- en warmwater-toevoer dienen vermeden te worden.

MONTAGE-INSTRUCTIES

- / Vóór de montage moet het product gecontroleerd worden op transportschade. Na de inbouw wordt geen transport- of oppervlakteschade meer aanvaard.
- / De leidingen en armaturen moeten gemonteerd, gespoeld en gecontroleerd worden volgens de geldige normen.
- / De in de overeenkomstige landen geldende installatierichtlijnen moeten nageleefd worden.

SYMBOOLBESCHRIJVING

Gebruik geen zuurhoudende silicone!



Wandversterking noodzakelijk voor montage



MATEN (zie blz. 17)

TOEBEHOREN (behoort niet tot het leveringspakket)



/ dichtmanchet #96492000 (zie blz. 22) De dichtmanchet mag niet warm omwikkeld worden.



SERVICE ONDERDELEN (zie blz. 22)



KLEURSET (zie blz. 21)



KEURMERK (zie blz. 17)

△ SIKKERHEDSANVISNINGER

- △ Ved monteringen skal der bruges handsker for at undgå kvæstelser og snitsår.
- △ Større trykforskelle mellem koldt og varmt vand bør udjævnes.

MONTERINGSANVISNINGER

- / Før monteringen skal produktet kontrolleres for transportskader. Efter monteringen godkendes transportskader eller skader på overfladen ikke længere.
- / Ledningerne og armaturerne skal monteres, skylles og kontrolleres iht. de gældende standarder.
- / Installationsbestemmelserne, der gælder i det enkelte land, skal overholdes.

SYMBOLBESKRIVELSE



Der må ikke benyttes eddikesyreholdig silikone!



Område nødvendigvægforstærkning



MÅLENE (se s. 17)

SPECIALTILBEHØR (ikke med i leveringsomfang)



/ tætningsmanchet #96492000 (se s. 22) Der må ikke bruges smeltelim til tætningsmancheten.



RESERVEDELE (se s. 22)



KAPPESÆT (se s. 21)



GODKENDELSE (se s. 17)

△ AVISOS DE SEGURANÇA

- △ Durante a montagem devem ser utilizadas luvas de protecção, de modo a evitar ferimentos resultantes de entalamentos e de cortes.
- △ Grandes diferenças entre as pressões das águas quente e fria devem ser compensadas.

AVISOS DE MONTAGEM

- / Antes da montagem deve-se controlar o produto relativamente a danos de transporte. Após a montagem não são aceites quaisquer danos de transporte ou de superfície.
- / As tubagens e a torneira têm que ser montadas, enxaguadas e verificadas de acordo com as normas em vigor.
- / A prescrições de instalação válidas nos respetivos países devem ser respeitadas.

DESCRIÇÃO DO SÍMBOLO



Não utilizar silicone que contenha ácido acético!



Área reforçada necessária da parede



MEDIDAS (ver página 17)

ACESSÓRIOS ESPECIAIS (não incluído no volume de fornecimento)



/ Disco de borracha #96492000 (ver página 22) A junta de vedação não pode ser colada a quente.



PEÇAS DE SUBSTITUIÇÃO (ver página 22)



CONJUNTO COMPLETO (ver página 21)



MARCA DE CONTROLO (ver página 17)

△ WSKAZÓWKI BEZPIECZEŃSTWA

- △ Aby uniknąć zranień na skutek zgniecenia lub przecięcia, podczas montażu należy nosić rękawice ochronne.
- △ Znaczące różnice ciśnień na dopływach ciepłej i zimnej wody muszą zostać wyrównane.

WSKAZÓWKI MONTAŻOWE

- / Przed montażem należy skontrolować produkt pod kątem szkód transportowych. Po montażu nie widać żadnych szkód transportowych ani szkód na powierzchni.
- / Przewody i armatura muszą być montowane, płukane i kontrolowane według obowiązujących norm.
- / Należy przestrzegać wytycznych instalacyjnych obowiązujących w danym kraju.

OPIS SYMBOLU

Nie stosować silikonów zawierających kwas octowy!



Niezbędne wzmocnienie ścian



WYMIARY (patrz strona 17)

WYPOSAŻENIE SPECJALNE (Nie jest częścią dostawy)



/ Uszczelka mocująca #96492000 (patrz strona 22) Kołnierz uszczelniający nie może być przyklejany na gorąco.



CZĘŚCI SERWISOWE (patrz strona 22)



ELEMENTY ZEWNĘTRZNE (patrz strona 21)



ZNAK JAKOŚCI (patrz strona 17)

MONTAŻ (patrz strona 18)

△ BEZPEČNOSTNÍ POKYNY

- △ Pro zabránění řezným zraněním a pohmožděninám je nutné při montáži nosit rukavice.
- △ Je nutné vyrovnat velké rozdíly tlaku mezi přípoji studené a teplé vody.

POKYNY K MONTÁŽI

- / Před montáží je třeba produkt zkontrolovat, zda nebyl při transportu poškozen. Po zabudování nebudou uznány žádné škody způsobené transportem nebo poškození povrchu.
- / Vedení a armatura musí být namontovány, propláchnuty a otestovány podle platných norem.
- / Je třeba dodržovat montážní pravidla platné v dané zemi.

POPIS SYMBOLŮ

Nepoužívat silikon s obsahem kyseliny octové!



nutné vyztužení stěny



ROZMĚRY (viz strona 17)

ZVLÁŠTNÍ PŘÍSLUŠENSTVÍ (není součástí dodávky)



/ těsnicí manžeta #96492000 (viz strona 22) Těsnicí manžeta nesmí být slepená za horka.



SERVISNÍ DÍLY (viz strona 22)



VRCHNÍ SADA (viz strona 21)



ZKUŠEBNÍ ZNAČKA (viz strona 17)

MONTÁŽ (viz strona 18)

△ BEZPEČNOSTNÉ POKYNY

- △ Pri montáži musíte nosiť rukavice, aby ste predišli pomliaždeninám a rezným poraneniam.
- △ Veľké rozdiely v tlaku medzi prípojkami studenej a teplej vody musia byť vyrovnané.

POKYNY PRE MONTÁŽ

- / Pred montážou musíte produkt skontrolovať, či nebol počas transportu poškodený. Po zabudovaní nebudú uznané žiadne škody spôsobené transportom alebo poškodenia povrchu.
- / Ledningarna och blandaren måste monteras, spolás igenom och kontrolleras enligt de gällande normerna.
- / Je potrebné dodržiavať smernice o inštalácii, ktoré sú práve teraz platné v krajinách.

POPIS SYMBOLOV



Nepoužívať silikón s obsahom kyseliny octovej!



Potrebné zosilnenie steny



ROZMERY (viď strana 17)



ZVLÁŠTNE PRÍSLUŠENSTVO (nie je súčasťou dodávky)

- / tesniaca manžeta #96492000 (viď strana 22) Tesniaca manžeta nesmie byť lepená za horúca.



SERVISNÉ DIELY (viď strana 22)



VRCHNÁ SADA (viď strana 21)



OSVEDČENIE O SKÚŠKE (viď strana 17)

△ 安全技巧

- △ 装配时为避免挤压和切割受伤，必须戴上手套。
- △ 冷热水管间过大的压力差必须予以平衡。

安装提示

- / 安装前必须检查产品是否受到运输损害。安装后将不认可运输损害或表面损伤。
- / 管道和阀门必须根据通用标准进行安装、冲洗和检查。
- / 请遵守当地国家现行的安装规定。

符号说明



请勿使用含有乙酸的硅胶！



墙壁必要加强的区域



大小 (参见第 17)

选装附件 (不在供货范围内)



- / 密封箔 #96492000 (参见第 22) 不能热粘贴密封涂层。



备用零件 (参见第 22)



加工件 (参见第 21)



检验标记 (参见第 17)

△ УКАЗАНИЯ ПО ТЕХНИКЕ БЕЗОПАСНОСТИ

- △ Во время монтажа следует надеть перчатки во избежание прищемления и порезов.
- △ донного клапа. Перед установкой смесителя необходимо регулировочными кранами выровнять давление холодной и горячей воды при помощи вентилей регулирующих подачу воды в квартиру.

УКАЗАНИЯ ПО МОНТАЖУ

- / Перед монтажом следует проверить изделие на предмет повреждений при перевозке. После монтажа претензии о возмещении ущерба за повреждения при перевозке или повреждения поверхностей не принимаются.
- / Трубы и арматура должны быть установлены, промыты и проверены в соответствии с действующими нормами.
- / Необходимо соблюдать требования по монтажу, действующие в соответствующих странах.

ОПИСАНИЕ СИМВОЛОВ



Не применяйте силикон, содержащий уксусную кислоту.



Необходимо усиление стены



РАЗМЕРЫ (см. стр. 17)

СПЕЦИАЛЬНЫЕ ПРИНАДЛЕЖНОСТИ (не включено в объем поставки!)



/ Уплотнительная манжета #96492000 (см. стр. 22) Уплотнительную манжету не разрешается приклеивать горячим способом.



КОМПЛЕКТ (см. стр. 22)



НАРУЖНАЯ ЧАСТЬ (см. стр. 21)



ЗНАК ТЕХНИЧЕСКОГО КОНТРОЛЯ (см. стр. 17)

△ BIZTONSÁGI UTASÍTÁSOK

- △ A szerelésnél a zúzódások és vágási sérülések elkerülése érdekében kesztyűt kell viselni.
- △ A hidegvíz- és a melegvíz-csatlakozások közötti nagy nyomáskülönbséget kell egyenlíteni!

SZERELÉSI UTASÍTÁSOK

- / A szerelés előtt ellenőrizni kell, hogy a terméknek nincs-e szállítási sérülése. Beépítés után a szállítási- vagy felületi sérüléseket nem ismerik el.
- / A vezetékeket és a csaptelepet az érvényes szabványoknak megfelelően kell felszerelni, öblíteni és ellenőrizni
- / Az egyes országokban érvényes installációs irányelveket kell tartani.

SZIMBÓLUMOK LEÍRÁSA



Ne használjon ecetsavtartalmú szilikont!



Szükséges a fal megerősítése



MÉRETET (lásd a oldalon 17)

EGYÉB TARTOZÉK (a szállítási egység nem tartalmazza)



/ Tömítőkarima #96492000 (lásd a oldalon 22)A szigetelő gumigyűrűt nem szabad forróan felragasztani.



TARTOZÉKOK (lásd a oldalon 22)



A KÉSZ SZERELVÉNY (lásd a oldalon 21)



VIZSGAJEL (lásd a oldalon 17)



△ TURVALLISUUSOHJEET

- △ Asennuksessa on käytettävä käsiineitä puristumien ja viiltojen aiheuttamien tapaturmien estämiseksi.
- △ Suuret paine-erot kylmä- ja kuumavesiliitännöiden välillä on tasattava.

ASENNUSOHJEET

- / Ennen asennusta on tarkastettava tuotteen mahdolliset kuljetusvahingot. Asennuksen jälkeen kuljetus- ja pintavaurioita ei hyväksytä.
- / Putket ja hana on asennettava, huuhdeltava ja tarkastettava voimassa olevien standardien mukaisesti.
- / Jokaisessa maassa on noudatettava siellä päteviä asennusohjeita.

△ SÄKERHETSANVISNINGAR

- △ Handskar ska bäras under monteringsarbetet så att man kan undvika kläm- och skärskadorgen werden.
- △ Stora tryckskillnader mellan anslutningarna för varmt och kallt vatten måste utjämnas.

MONTERINGSANVISNINGAR

- / Det måste undersökas om produkten har transportskador innan den monteras. Efter monteringen accepteras inga transport- eller ytskiktskador.
- / Ledningarna och blandaren måste monteras, spolats igenom och kontrolleras enligt de gällande normerna.
- / De installationsriktlinjer som gäller i länderna ska följas.

MERKIN KUVAUS



Älä käytä etikahappopitoista silikonial



Seinän vahvistus on tarpeen



MITAT (katso sivu 17)

ERITYISVARUSTE (ei kuulu toimitukseen)



/ Tiivisterengas #96492000 (katso sivu 22)
Tiivistekaulusta ei saa kuumaliimata.



VARAOSAT (katso sivu 22)



VALMISSARJA (katso sivu 21)



KOESTUSMERKKI (katso sivu 17)

SYMBOLFÖRKLARING



Använd inte silikon som innehåller ättiksyra!



Väggförstärkning nödvändig



MÅTTEN (se sidan 17)

SPECIALTILLBEHÖR (medföljer ej leveransen)



/ Tätningsmanschett #96492000 (se sidan 22)
Tätningsmanschetten får inte varmlimmas.



RESERVDELAR (se sidan 22)



FÄRDIGSET (se sidan 21)



TESTSIGILL (se sidan 17)

SAUGUMO TECHNIKOS NURODYMAI

- ⚠ Apsaugai nuo užspaudimo ir įsijovimo montavimo metu mūvėkite pirštines.
- ⚠ Turi būti išlyginti šalto ir karšto slėgio nelygumai.

MONTAVIMO INSTRUKCIJA

- / Prieš montuojant būtina patikrinti, ar gaminy nebuvu pažeistas transportavimo metu. Šumontavus pretenzijos dėl transportavimo ir paviršiaus pažeidimų nepriimamos.
- / Vamzdžiai ir sujungimai turi būti montuojami, plaunami ir tikrinami pagal galiojančias normas.
- / Laikykitės atitinkamoje šalyje galiojančių direktyvų dėl įrengimo.

SIMBOLIO APRAŠYMAS

-  Nenaudokite silikono, kurio sudėtyje yra acto rūgšties!
-  Būtinai sienos sutvirtinimas
-  IŠMATAVIMAI (žr. psl. 17)
- SPECIALŪS PRIEDAI (nėra pridedama)
-  / Sandarikliai #96492000 (žr. psl. 22) Sandariklio nekljuokite karštuoju būdu.
-  ATSARGINĖS DALYS (žr. psl. 22)
-  VIRŠTINKINĖ (žr. psl. 21)
-  BANDYMO PAŽYMA (žr. psl. 17)

MONTAVIMAS (žr. psl. 18) 







SIGURNOSNE UPUTE

- ⚠ Prilikom montaže se radi sprječavanja prignječenja i posjekotina moraju nositi rukavice.
- ⚠ Velika razlika u pritisku između vruće i hladne vode mora biti izbalansirana.

UPUTE ZA MONTAŽU

- / Prije montaže mora se provjeriti je li proizvod oštećen prilikom transporta. Nakon ugradnje se ne priznaju nikakve reklamacije koje se odnose na površinska i transportna oštećenja.
- / Cijevi i armatura moraju biti postavljeni, isprani i testirani prema važećim normama.
- / Obvezno se moraju uvažiti propisi o instalacijama koji vrijede u dotičnoj zemlji.

OPIS SIMBOLA

-  Nemojte koristiti silikon koji sadrži octenu kiselinu!
-  neophodno ojačanje zida
-  MJERE (pogledaj stranicu 17)
- POSEBNI PRIBOR (Nije sadržano u isporuci!)
-  / Manžeta za brtvljenje #96492000 (pogledaj stranicu 22) Manžetu za brtvljenje ne smijete lijepiti vrućim ljepilom.
-  REZERVNI DJELOVI (pogledaj stranicu 22)
-  ZAVRŠNI SET (pogledaj stranicu 21)
-  OZNAKA TESTIRANJA (pogledaj stranicu 17)

SASTAVLJANJE (pogledaj stranicu 18) 



⚠ GÜVENLİK UYARILARI

- ⚠ Montaj esnasında ezilme ve kesilme gibi yaralanmaları önlemek için eldiven kullanılmalıdır.
- ⚠ Sıcak ve soğuk su bağlantıları arasında büyük basınç farklılıkları varsa, bu basınç farklılıklarının dengelenmesi gerekir.

MONTAJ AÇIKLAMALARI

- / Montaj işleminden önce ürün nakliye hasarları yönünden kontrol edilmelidir. Montaj işleminden sonra nakliye veya yüzey hasarları için sorumluluk üstlenilmemektedir.
- / Boruların ve armatürün montajı, yıkanması ve kontrolü geçerli normlara göre yapılmalıdır.
- / Ülkelerde geçerli kurulum yönetmeliklerine riayet edilmelidir.

SİMGE AÇIKLAMASI

-  Asetik asit içeren silikon kullanmayın!
-  Duvar takviyesi gereklidir
-  ÖLÇÜLERİ (bakınız sayfa 17)
- ÖZEL AKSESUARLAR (Teslimat kapsamına dahil değildir)

-  / Sızdırmazlık manşeti #96492000 (bakınız sayfa 22)Körük sıcak tutkalanmamalıdır.

-  YEDEK PARÇALAR (bakınız sayfa 22)

-  DIŞI SET (bakınız sayfa 21)

-  KONTROL İŞARETİ (bakınız sayfa 17)



⚠ INSTRUCȚIUNI DE SIGURANȚĂ

- ⚠ La montare utilizați mănuși pentru evitarea contuziunilor și tăierii mâinilor.
- ⚠ Diferențele de presiune mari între alimentarea cu apă rece și apă caldă trebuie echilibrate.

INSTRUCȚIUNI DE MONTARE

- / Înainte de instalare verificați, dacă produsul prezintă deteriorări de transport. După instalare garanția nu acoperă deteriorările de transport și cele de suprafață.
- / Conductele și bateriile trebuie montate, spălate și verificate conform normelor în vigoare.
- / Respectați reglementările referitoare la instalare valabile în țara respectivă.

DESCRIEREA SIMBOLURILOR

-  Nu utilizați silicon cu conținut de acid acetic!
-  Este nevoie de consolidarea pereții.

-  DIMENSIUNI (vezi pag. 17)

- ACCESORII OPȚIONALE (nu este inclus în setul livrat)

-  / Manșetă de etanșare #96492000 (vezi pag. 22)Manșeta de etanșare nu trebuie lipită la cald.

-  PIESE DE SCHIMB (vezi pag. 22)

-  SET COMPLET (vezi pag. 21)

-  CERTIFICAT DE TESTARE (vezi pag. 17)

⚠ ΥΠΟΔΕΙΞΕΙΣ ΑΣΦΑΛΕΙΑΣ

- ⚠ Για να αποφύγετε τραυματισμούς κατά τη συναρμολόγηση πρέπει να φοράτε γάντια.
- ⚠ Οι διαφορές της πίεσης μεταξύ της σύνδεσης κρύου και ζεστού νερού θα πρέπει να αντισταθμίζονται.

ΟΔΗΓΙΕΣ ΣΥΝΑΡΜΟΛΟΓΗΣΗΣ

- / Πριν τη συναρμολόγηση πρέπει να εξεταστεί το προϊόν για ζημιές μεταφοράς. Μετά την εγκατάσταση δεν αναγνωρίζονται ζημιές από τη μεταφορά ή επιφανειακές ζημιές.
- / Οι σωλήνες και η μπαταρία πρέπει να τοποθετηθούν σύμφωνα με τα ισχύοντα πρότυπα, να τεθούν υπό πίεση και να δοκιμαστούν.
- / Θα πρέπει να τηρούνται οι οδηγίες εγκατάστασης που ισχύουν σε κάθε κράτος.

ΠΕΡΙΓΡΑΦΗ ΣΥΜΒΟΛΩΝ

Μην χρησιμοποιείτε σιλικόνη που περιέχει οξικό οξύ!



Απαραίτητη ενίσχυση τοίχου



ΔΙΑΣΤΑΣΕΙΣ (βλ. Σελίδα 17)

ΕΙΔΙΚΑ ΑΞΕΣΟΥΑΡ (δεν περιλαμβάνεται στον παραδοτέο εξοπλισμό)



/ Στεγανοποιητικό παρέμβυσμα #96492000 (βλ. Σελίδα 22) Η περιμετρική στεγανοποίηση δεν πρέπει να κολληθεί εν θερμώ



ΑΝΤΑΛΛΑΚΤΙΚΑ (βλ. Σελίδα 22)



ΣΕΤ ΜΗΧΑΝΙΣΜΟΥ (βλ. Σελίδα 21)



ΣΗΜΑ ΕΛΕΓΧΟΥ (βλ. Σελίδα 17)

⚠ VARNOSTNA OPOZORILA

- ⚠ Pri montaži je treba nositi rokavice, da se preprečijo poškodbe zaradi zmečkanja ali urezov.
- ⚠ Velike razlike v tlaku med priključkom za mrzlo in priključkom za toplo vodo je potrebno izravnati.

NAVODILA ZA MONTAŽO

- / Pred montažo je treba izdelek preveriti glede morebitnih transportnih poškodb. Po vgradnji transportne ali površinske poškodbe ne bodo več priznane.
- / Cevi in armaturo je treba montirati, izprati in preveriti po veljavnih standardih.
- / Upoštevati je treba pravilnike o inštalacijah, ki veljajo v posamezni državi.

OPIS SIMBOLA

Ne smete uporabiti silikona, ki vsebuje očetno kislino!



Potrebno je ojačanje stene



MERE (glejte stran 17)

POSEBEN PRIBOR (Ni vključeno)



/ Tesnilna manšeta #96492000 (glejte stran 22) Tesnilna manšeta se ne sme zlepiti z vročim lepilom.



REZERVNI DELI (glejte stran 22)



ZAKLJUČNA GARNITURA (glejte stran 21)



PRESKUSNI ZNAK (glejte stran 17)

ΣΥΝΑΡΜΟΛΟΓΗΣΗ (βλ. Σελίδα 18) 

MONTAŽA (glejte stran 18) 

△ OHUTUSJUHISED

- △ Kandke paigaldamisel muljumis- ja löikevigastuste vältimiseks kindaid.
- △ Kui külma ja kuuma vee ühenduste surve on väga erinev, tuleb need tasakaalustada.

PAIGALDAMISJUHISED

- / Enne paigaldamist tuleb toodet kontrollida transpordikahjustuste osas Pärast paigaldamist ei tunnustata enam transpordi- või pinnakahjustuste kaebuseid.
- / Voolikute ja segisti paigaldamisel, loputamisel ja kontrollimisel tuleb lähtuda kehtivatest normatiividest
- / Vastavas riigis kehtivaid paigalduseeskirju tuleb järgida.

△ DROŠĪBAS NORĀDES

- △ Montāžas laikā, lai izvairītos no saspiedumiem un iegriezumiem, nepieciešams nēsāt cimdus.
- △ Jāizlīdzina spiediena atšķirības starp aukstā un karstā ūdens pievadiem.

NORĀDĪJUMI MONTĀŽAI

- / Pirms montāžas nepieciešams pārbaudīt, vai produktam transportēšanas laikā nav radušies bojājumi. Pēc iebūvēšanas bojājumi, kas radušies transportēšanas laikā, vai virsmas bojājumi netiek atzīti.
- / Cauruļvadi un armatūra ir jāuzstāda, jāizskalo un jāpārbauda saskaņā ar spēkā esošajiem standartiem.
- / Jāievēro attiecīgās valstīs spēkā esošās montāžas prasības.

SŪMBOLITE KIRJELDUS



Ārge kasutage ādikhapet sisaldavat silikoonil!



Vajalik seinatugevdus



MŪŅOTUDE (vt lk 17)

SPETSIAALNE LISAVARUSTUS (ei sisaldu komplektis)



/ tihendi #96492000 (vt lk 22) Tihendusmuhvi ei tohi kuumliimida.



VARUOSAD (vt lk 22)



VALMISKOMPLEKT (vt lk 21)



KONTROLLSERTIFIKAAT (vt lk 17)

SĪMBOLU NOZĪME



Neizmantoj silikonu, kas satur etiķskābi!



Nepieciešama sienas stiprināšana



IZMĒRUS (skat. lpp. 17)

SPECIĀLI AKSESUĀRI (komplektā netiek piegādāts)



/ Blīvējuma uzdeva #96492000 (skat. lpp. 22) Blīvēšanas manšeti nedrīkst salīmēt ar karstu ūdeni.



REZERVES DAĻAS (skat. lpp. 22)



KOMPLEKTS (skat. lpp. 21)



PĀRBAUDES ZĪME (skat. lpp. 17)

⚠ SIGURNOSNE NAPOMENE

- ⚠ Prilikom montaže se radi sprečavanja prignječenja i posekotina moraju nositi rukavice.
- ⚠ Velika razlika u pritisku između vruće i hladne vode mora biti izbalansirana.

INSTRUKCIJE ZA MONTAŽU

- / Pre montaže se mora proveriti da li je proizvod oštećen pri transportu. Nakon ugradnje se ne priznaju nikakve reklamacije koje se odnose na površinska i transportna oštećenja.
- / Vodovi i armatura moraju biti postavljeni, isprani i testirani prema važećim normama.
- / Treba se pridržavati propisa koji u određenim zemljama važe za instalacije.

OPIS SIMBOLA



Nemojte koristiti silikon koji sadrži sirćetnu kiselinu!



neophodno ojačanje zida



MERE (vidi stranu 17)

POSEBAN PRIBOR (Nije sadržano u isporuci)



/ Zaptivna manžetna #96492000 (vidi stranu 22) Zaptivna manžetna ne sme da se lepi vrućim lepkom.



REZERVNI DELOVI (vidi stranu 22)



ZAVRŠNI SET (vidi stranu 21)



ISPITNI ZNAK (vidi stranu 17)

⚠ SIKKERHETSHENVISNINGER

- ⚠ Bruk hansker under montasjen for å unngå klem- og kuttskader.
- ⚠ Store trykkdifferanser mellom kaldt- og varmtvannstilkoblinger skal utlignes.

MONTAGEHENVISNINGER

- / Før montasjen skal produktet sjekkes for transportskader. Etter monteringen aksepteres ikke noen transport- eller overflateskader.
- / Ledningene og armaturen skal monteres, spyles og sjekkes iht. de gyldige normer.
- / Gjeldende retningslinjer for rørleggerarbeid i de enkelte land skal følges.

SYMBOLBESKRIVELSE



Ikke bruk silikon som inneholder eddiksyre!



Veggforsterkning er nødvendig



MÅL (se side 17)

EKSTRATILBEHØR (ikke med i leveransen)



/ Tetningsmansjett #96492000 (se side 22) Tetningsmansjett må aldri limes varm.



SERVICEDELER (se side 22)



FERDIGSETT (se side 21)



PRØVEMERKE (se side 17)



▲ УКАЗАНИЯ ЗА БЕЗОПАСНОСТ

- ▲ При монтажа трябва да се носят ръкавици, за да се избегнат наранявания поради притискане или порязване.
- ▲ Големите разлики в налягането между изводите за студената и топлата вода трябва да се изравняват.

УКАЗАНИЯ ЗА МОНТАЖ

- / Преди монтажа продуктът трябва да се провери за транспортни щети. След монтажа не се признават транспортни или повърхностни щети.
- / Тръбопроводите и арматурата трябва да се монтират, промият и проверят в съответствие с валидните норми.
- / Трябва да бъдат спазвани валидните в съответните страни предписания за инсталиране.

▲ UDHËZIME SIGURIE

- ▲ Për të evituar lëndimet e pickimeve ose të prerjeve gjatë procesit të montimit duhet që të vishni doreza.
- ▲ Ndryshimet e mëdha të presionit mes lidhjeve të ujit të ftohtë dhe atij të ngrohtë duhen ekuilibruar.

UDHËZIME PËR MONTIMIN

- / Përpara montimit duhet që produkti të kontrollohet për dëmtime nga transporti. Pas instalimit nuk do të njihet asnjë dëmtim nga transporti ose dëmtim i sipërfaqes.
- / Tubacionet dhe rubinetet duhet që të montohen, të shpëlahen dhe të kontrollohen sipas standardeve në fuqi
- / Duhet të respektohen linjat udhëzuese të instalimit, të vlefshme për vendet respektive.

ОПИСАНИЕ НА СИМВОЛИТЕ



Не използвайте силикон, съдържащ оцетна киселина!



Необходимо е усилване на стената



РАЗМЕРИ (вижте стр. 17)

СПЕЦИАЛНИ ПРИНАДЛЕЖНОСТИ (не се съдържа в обема на доставка)



/ Уплътнителен маншет #96492000 (вижте стр. 22) Уплътнителният маншет не трябва да се лепи по топъл начин.



СЕРВИЗНИ ЧАСТИ (вижте стр. 22)



ГОТОВ НАБОР (вижте стр. 21)



КОНТРОЛЕН ЗНАК (вижте стр. 17)

PËRSHKRIMI I SIMBOLIT



Mos përdorni silikon që në përbërje ka acid acetik.



Nevojitet përforcimi i murit



PËR MASAT (shih faqen 17)

PAJISJE TË POSAÇME (nuk përfshihet në vëllimin e furnizimit)



/ Mansheta izoluese #96492000 (shih faqen 22) Mansheta izoluese nuk duhet ngjitur me ngjithës të nxehtë.



PJESËT E SERVISIT (shih faqen 22)



KOMPLET I GATSHËM (shih faqen 21)



SHENJA E KONTROLLIT (shih faqen 17)

⚠️ تنبيهات الأمان

⚠️ يجب إرتداء قفازات لليد أثناء التركيب لتجنب حدوث أخطار الإنحشار أو الجروح.

⚠️ يجب أن يكون تيار الماء الساخن والماء البارد متعادلين في الضغط.

تعليمات التركيب

/ قبل القيام بعملية التركيب، يجب فحص المنتج للتأكد من خلوه من أية تلفيات ناتجة عن النقل. بعد القيام بعملية التركيب، لن يتم الاعتراف بوجود أية تلفيات سطحية أو تلفيات ناتجة عن عملية النقل.

/ يجب تركيب وغسيل واختبار التوصيلات وخلطات المياه طبقاً للمعايير السارية.

/ يجب مراعاة القواعد الخاصة بالتركيب وأعمال السباكة وفقاً للوائح الخاصة بكل بلد.

وصف الرمز

هام! لا تستخدم السليكون الذي يحتوي على أحماض!



المنطقة الخاصة بالتدعيم المطلوب للجدار



أبعاد (راجع صفحة 17)



ملحقات خاصة (غير مدرج مع المحتويات المسلمة)

/ رقاقة إغلاق #96492000 (راجع صفحة 22) لا يسمح بلمس الكم المانع للتسرب على الساخن.



قطع الغيار (راجع صفحة 22)



مجموعة كاملة. (راجع صفحة 21)



شهادة اختبار (راجع صفحة 17)



التركيب (راجع صفحة 18)





AXOR Massaud
18471180

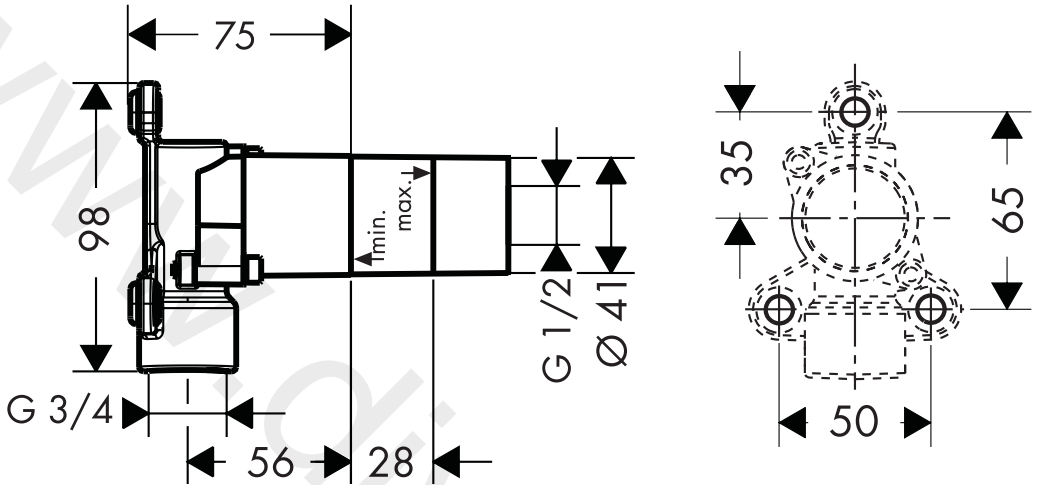

P-IX

DVGW

SVGW

ACS

WRAS

ETA

18471180

P-IX 18456/110



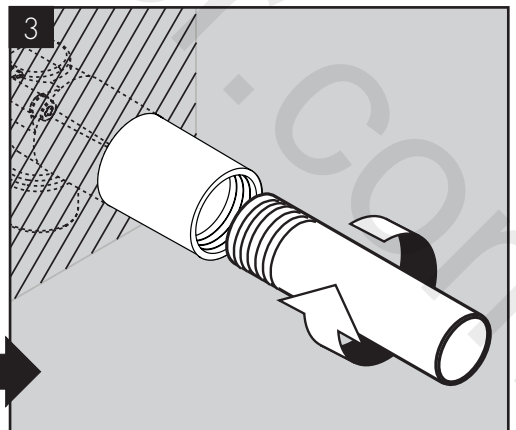
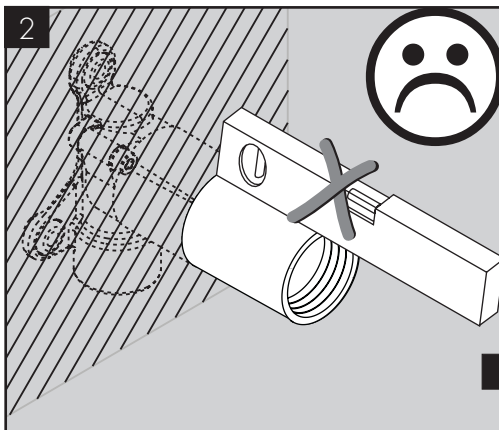
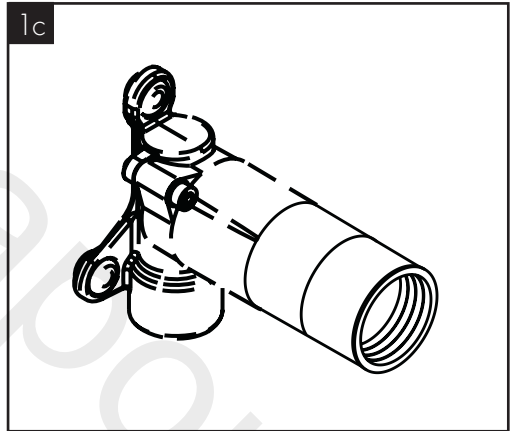
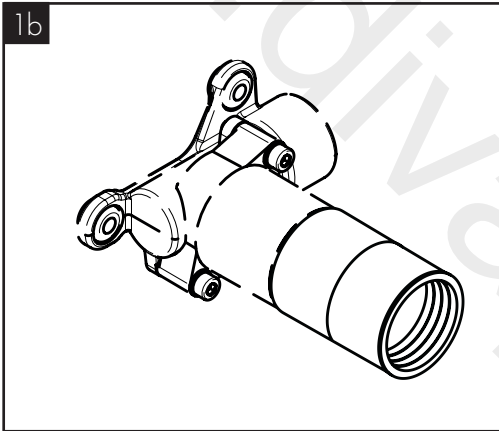
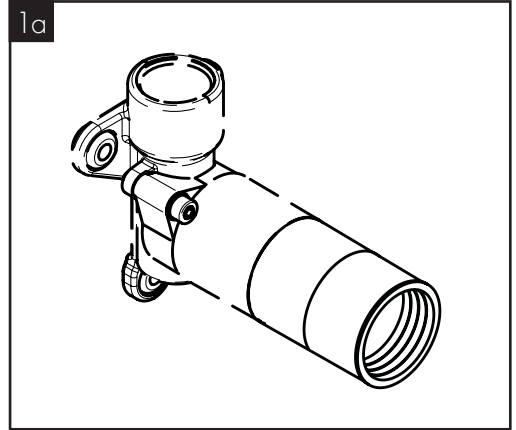
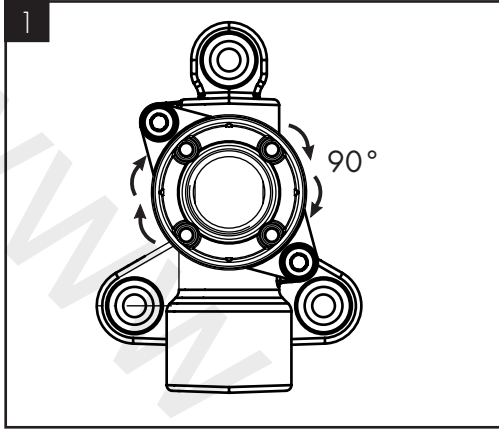

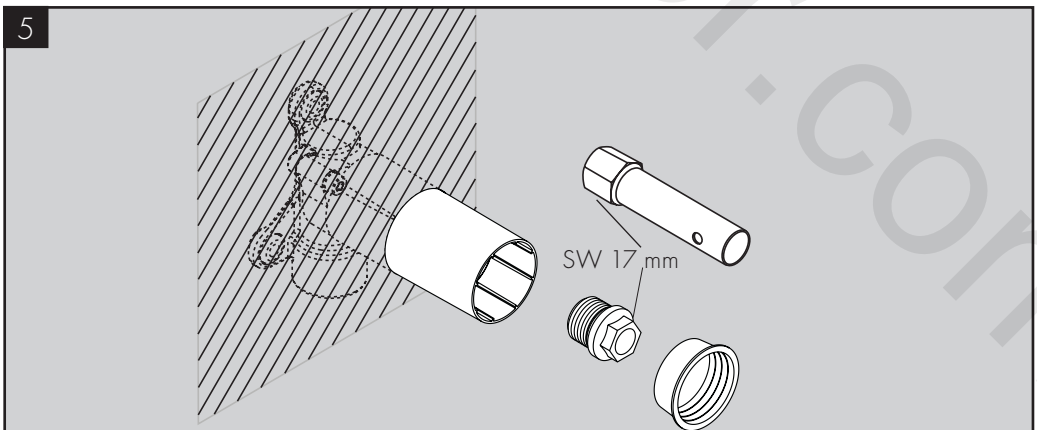
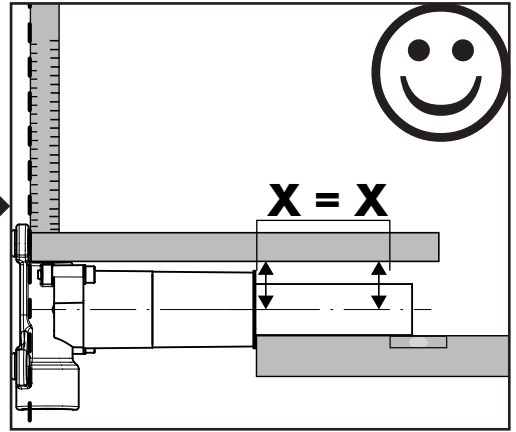
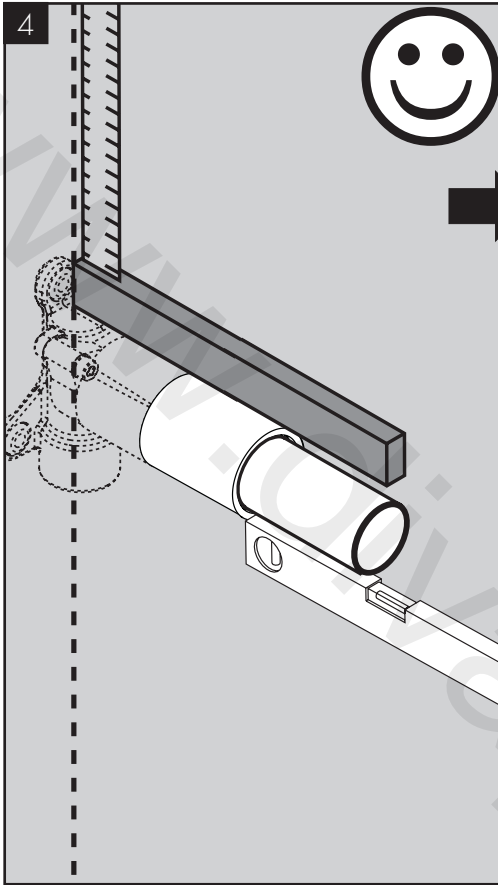

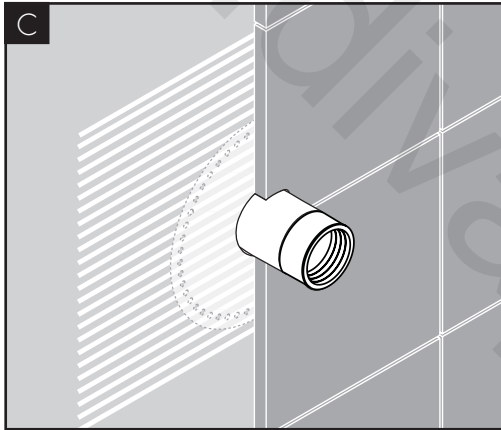
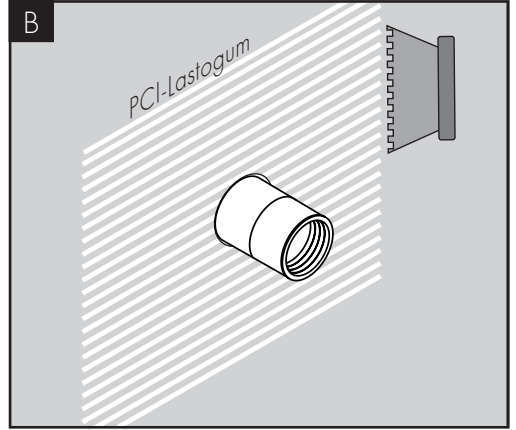
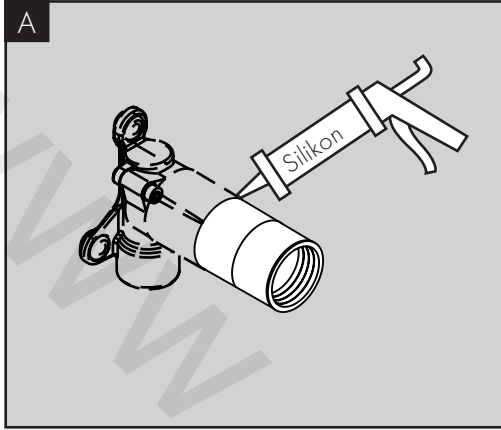



AXOR Massaud
18472000

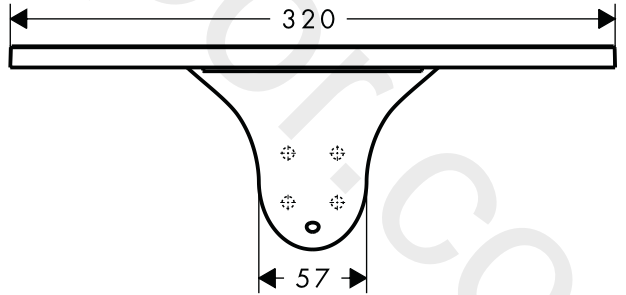
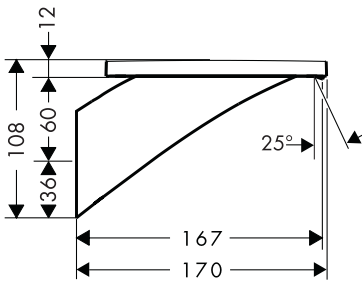
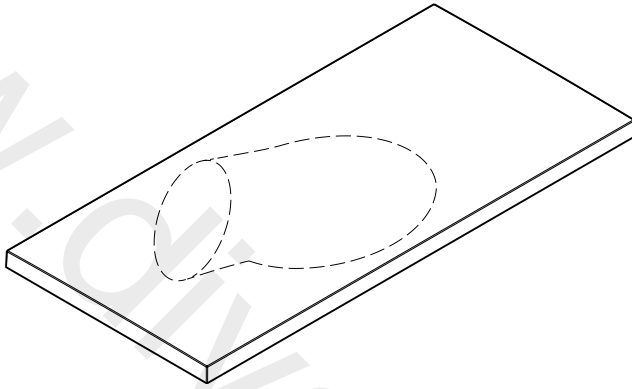

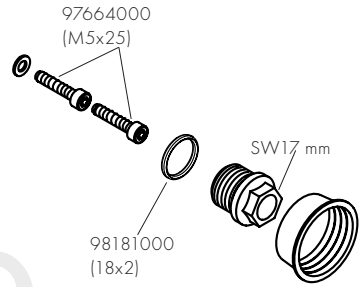
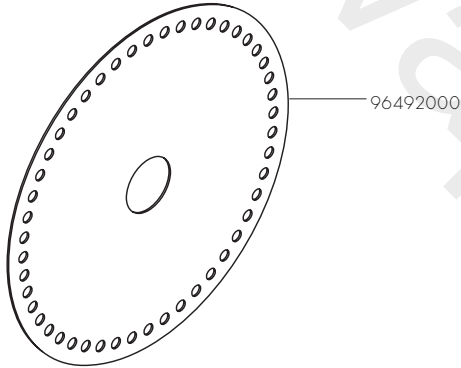
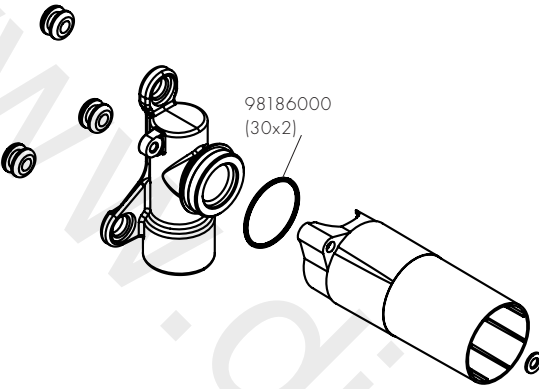

www.driveaport.com

www.divapor.com

AXOR

www.divapor.com

AXOR / Hansgrohe SE
Austraße 5-9
77761 Schiltach
Deutschland

info@axor-design.com
axor-design.com

12/2017
9.04132.01