

AXOR

EN / Assembly instructions

FR / Instructions de montage

ES / Instrucciones de montaje

www.divapor.com

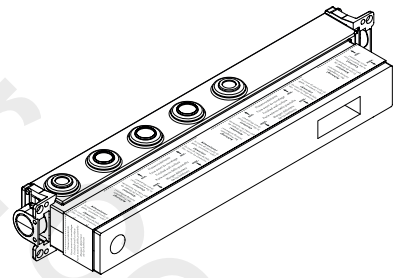

AXOR Select
18311181

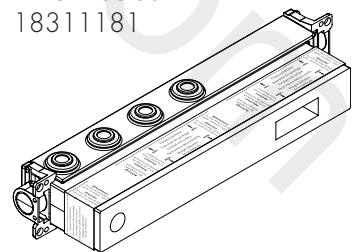

AXOR Select
18310181

INSTALLATION

ENGLISH

TECHNICAL INFORMATION

Water pressure	
Recommended	15 - 75 PSI (0.1 - 0.5 MPa)
Maximum	145 PSI (1 MPa)
Hot water temp.	
Recommended	120°-140° F (48° - 60° C)*
Maximum	158°F (70° C)*
Max. flow rate (with trim kit installed)	1.75 GPM

* Please know and follow all applicable local plumbing codes when setting the temperature on the water heater.

INSTALLATION CONSIDERATIONS

/ Please read over these instructions thoroughly before beginning installation. Make sure that you have all tools and supplies needed to complete the installation.

/ Inspect this product thoroughly before installation. Claims for shipping damage made after installation will not be honored.

/ For best results, Hansgrohe recommends that this unit be installed by a licensed, professional plumber.

/ The thermostatic cartridge and shutoff cartridges are included with the trim kit.

/ Rough 18310181 only: this valve is for one shower function plus a handshower.

/ Rough 18311181 only: this valve is for two shower functions plus a handshower.

⚠ The thermostatic mixer must be installed with the ¾" hot and cold inlet ports facing downwards (illustration A).

⚠ Do not install the mixer with the inlets facing upwards or to the side (illustration B).

/ The rough does not include stops. If stops are desired, install them on the hot and cold supplies in an easily accessible location outside the shower. Stops are not available from Hansgrohe.

/ The thermostatic mixer is for use with shower heads rated at 1.3 GPM (5.0 L/min) or higher.

/ To prevent scald injury, the maximum output temperature of the shower mixing valve (not included) must be no higher than 120°F (49°C). In Massachusetts, the maximum output temperature can be no higher than 112°F (44°C).

/ Keep this booklet and the receipt (or other proof of date and place of purchase) for this product in a safe place. The receipt is required should it be necessary to request warranty parts.

FRANÇAIS

DONNÉES TECHNIQUES

Pression d'eau	
recommandée	15 - 75 PSI (0.1 - 0.5 MPa)
maximum	145 PSI (1 MPa)
Température d'eau chaude	
recommandée	120°-140° F (48° - 60° C)*
maximum	158°F (70° C)*
Capacité nominale	1.75 GPM (6.6 L/min)

* Vous devez connaître et respecter tous les codes de plomberie locaux applicables pour le réglage de la température du chauffe-eau.

À PRENDRE EN CONSIDÉRATION POUR L'INSTALLATION

/ Pour de meilleurs résultats, Hansgrohe recommande que ce produit soit installé par un plombier professionnel licencié.

/ Avant son montage, s'assurer que le produit n'a subi aucun dommage pendant le transport. Après le montage, tout dommage de transport ou de surface ne pourra pas être reconnu.

/ Veuillez lire attentivement ces instructions avant de procéder à l'installation. Assurez-vous de disposer de tous les outils et du matériel nécessaires pour l'installation.

/ La cartouche thermostatique et les cartouches d'arrêt sont fournies avec le jeu de garniture.

/ Robinetterie brute 18310181 uniquement : cette valve est destinée à une fonction de douche plus une douchette. À utiliser avec la garniture 18355XXX (non fournie).

/ Robinetterie brute 18311181 uniquement : cette valve est destinée à deux fonctions de douche plus une douchette. À utiliser avec la garniture 18356XXX (non fournie).

⚠ Le mitigeur thermostatique doit être installé avec les ports d'alimentation d'eau chaude et froide de ¾ po orientés vers le bas (illustration A).

⚠ N'installez pas le mitigeur avec les ports orientés vers le haut ou le côté (illustration B).

/ La pièce intérieure n'inclut pas de robinets d'arrêt. Si vous voulez des robinets d'arrêt, installez-les sur les conduites d'alimentation d'eau chaude et d'eau froide dans un endroit facilement accessible à l'extérieur de la douche. Les robinets d'arrêt ne sont pas disponibles auprès de Hansgrohe.

/ Ce produit devrait être seulement utilisé avec les pommes de douche évaluées à 1.3 GPM (5.0 L/min) ou plus.

/ Pour empêcher des blessures par ébullition, la température de sortie maximale du robinet de douche ne doit pas excéder 120°F (49°C). Au Massachusetts, la température de sortie maximale du robinet de douche ne doit pas excéder 112°F (44°C).

/ Conservez ce livret et le reçu (ou une autre preuve sur laquelle figurent la date et l'endroit de l'achat) pour ce produit dans un endroit sûr. Le reçu est requis si vous commandez des pièces sous garantie.

ESPAÑOL

DATOS TÉCNICOS

Presión en servicio	
recomendada	15 - 75 PSI (0.1 - 0.5 MPa)
max.	145 PSI (1 MPa)
Temperatura del agua caliente	
recomendada	120°-140° F (48° - 60° C)*
max.	158°F (70° C)*
Caudal máximo	1.75 GPM (6.6 L/min)

* Debe conocer y cumplir todos los códigos locales aplicables para ajustar la temperatura del calentador de agua.

CONSIDERACIONES PARA LA INSTALACIÓN

/ Para obtener mejores resultados, la instalación debe estar a cargo de un plomero profesional matriculado.

/ Antes del montaje se debe examinarse el producto contra daños de transporte. Después de la instalación no se reconoce ningún daño de transporte o de superficie.

/ Antes de comenzar la instalación, lea estas instrucciones detenidamente. Asegúrese de tener las herramientas y los insumos necesarios para completar la instalación.

/ El cartucho termostático y los cartuchos de cierre se incluyen en el kit de pieza exterior.

/ Únicamente pieza interior de válvula 18310181: esta válvula es para función de una ducha más una ducha de mano. Debe instalarse con una pieza exterior 18355XXX (no incluida).

/ Únicamente pieza interior de válvula 18311181: esta válvula es para función de dos duchas más una ducha de mano. Debe instalarse con una pieza exterior 18356XXX (no incluida).

⚠ El mezclador termostático debe instalarse con los puertos de entrada de agua caliente y fría de ¾" mirando hacia abajo (ilustración A).

⚠ No instale el mezclador con las entradas mirando hacia arriba o al costado (ilustración B).

/ La pieza interior no incluye topes. Si desea topes, instálelos en los suministros de agua caliente y fría en una ubicación de fácil acceso fuera de la ducha. Hansgrohe no le proporciona los topes.

/ Este producto debe ser utilizado sólo con alcachofas de la ducha valoradas en 1.3 GPM (5.0 L/min) o más.

/ Para evitar escaldaduras, la máxima temperatura de salida de la válvula de la ducha no debe exceder los 120°F (49°C). En Massachusetts, la máxima temperatura de salida de la válvula de la ducha no debe exceder los 112°F (44°C).

/ Mantenga este folleto y el recibo (u otro comprobante del lugar y fecha de compra) de este producto en lugar seguro. El recibo se requiere en caso de ser necesario solicitar piezas bajo garantía.

AXOR Select
18310181

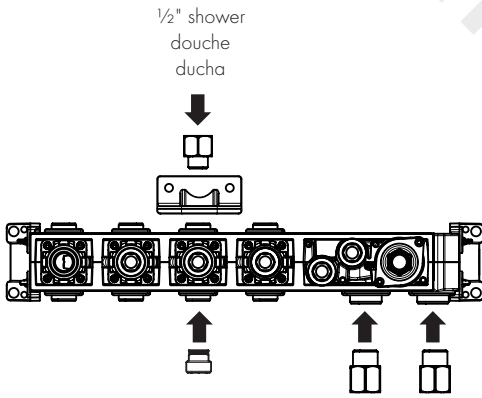
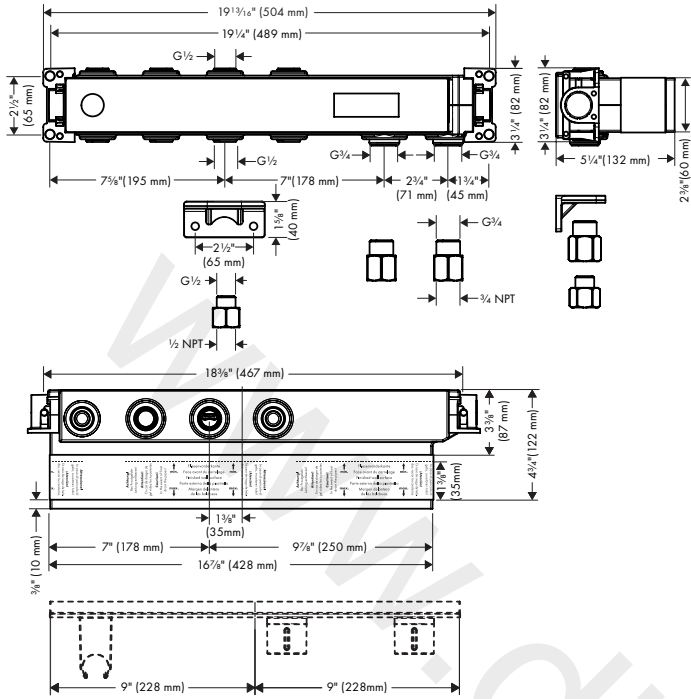

1/2" shower
douche
ducha

3/4" hot
chaud
caliente

3/4" cold
froid
frío

AXOR Select
18311181

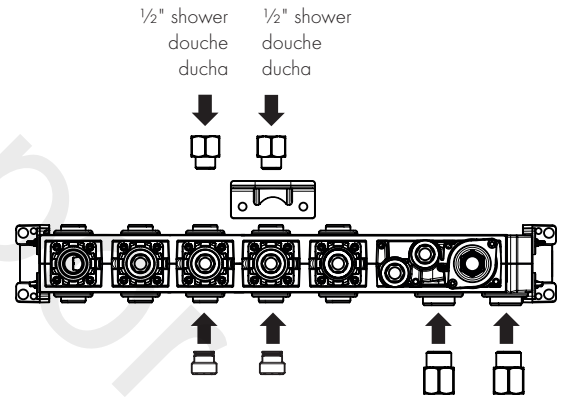
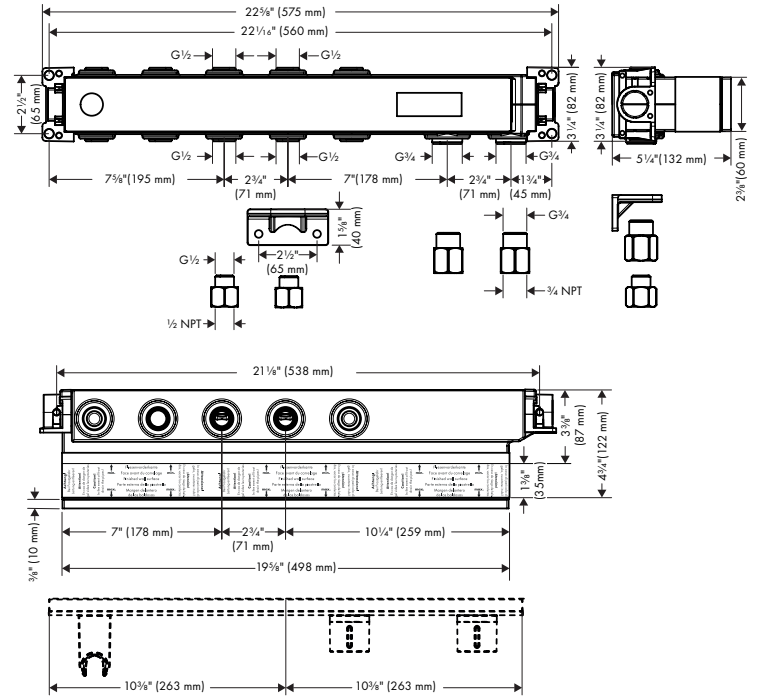

1/2" shower
douche
ducha

1/2" shower
douche
ducha

3/4" hot
chaud
caliente

3/4" cold
froid
frío

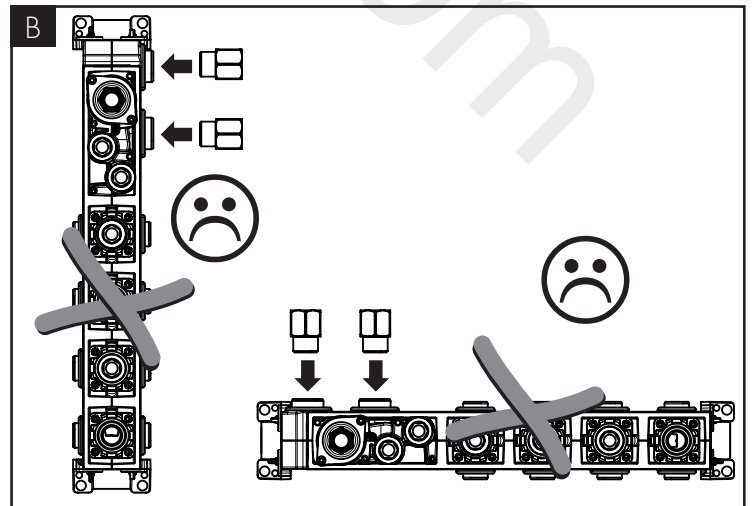
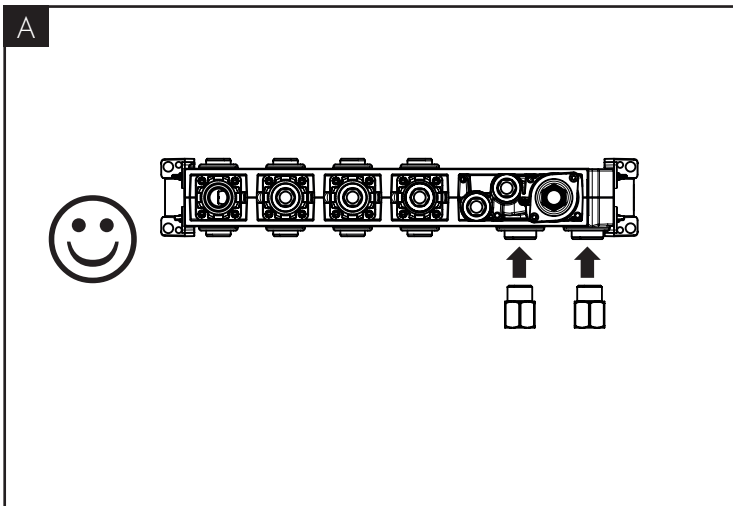

INSTALLATION SUGGESTIONS / SUGGESTIONS D'INSTALLATION /
SUGERENCIAS PARA LA INSTALACIÓN

AXOR Select
18310181

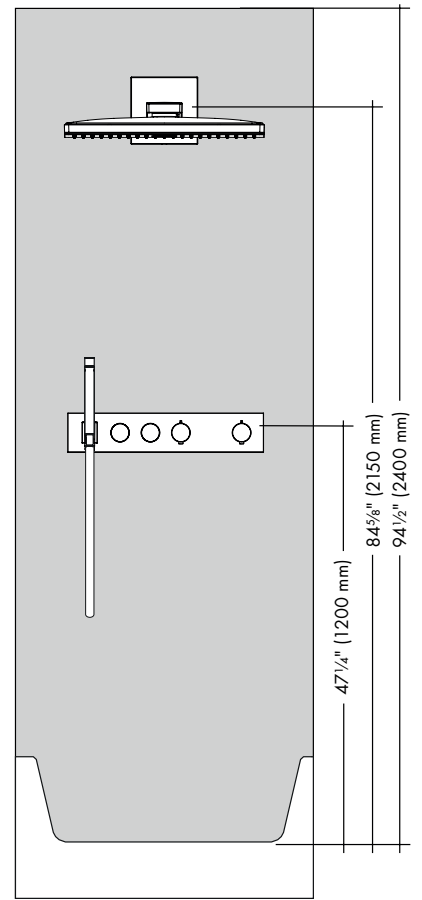
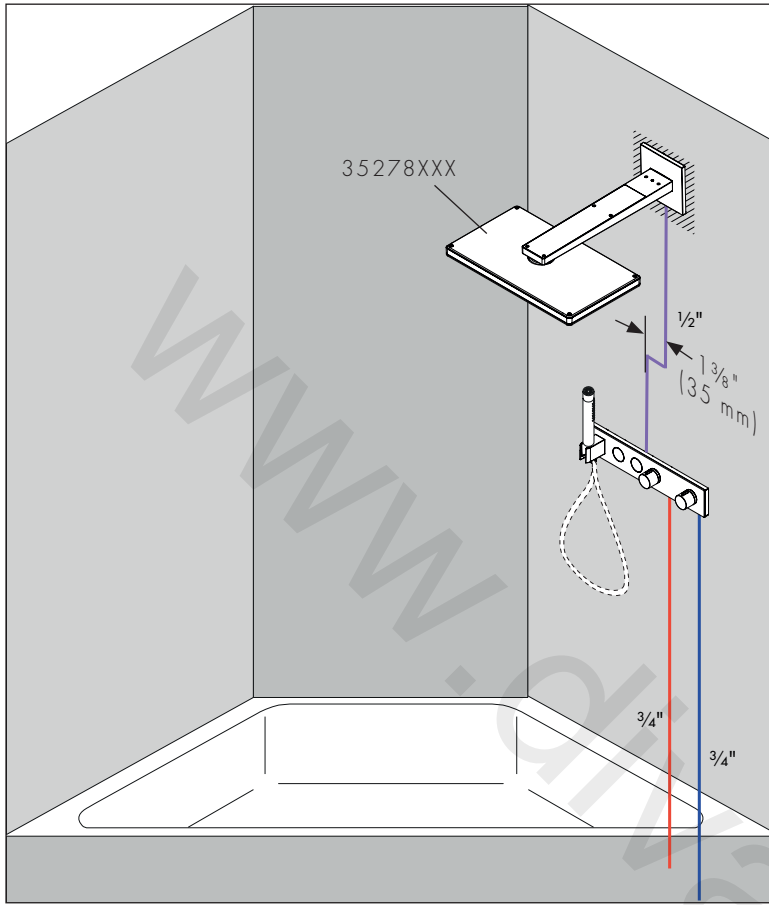

AXOR Select
18311181

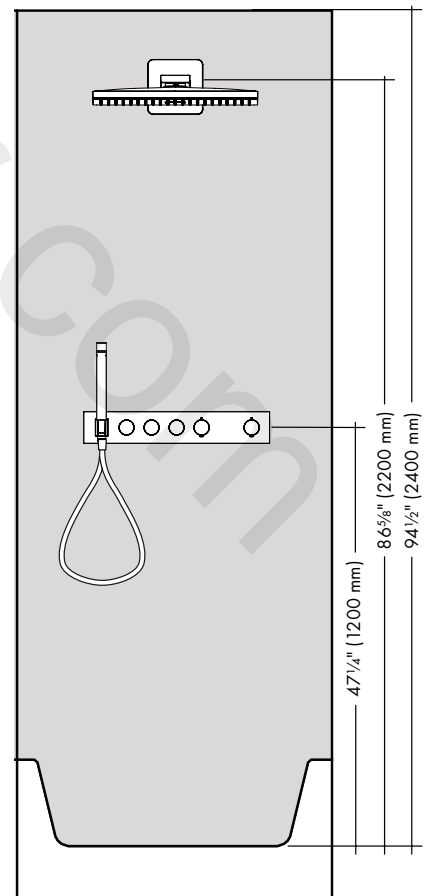
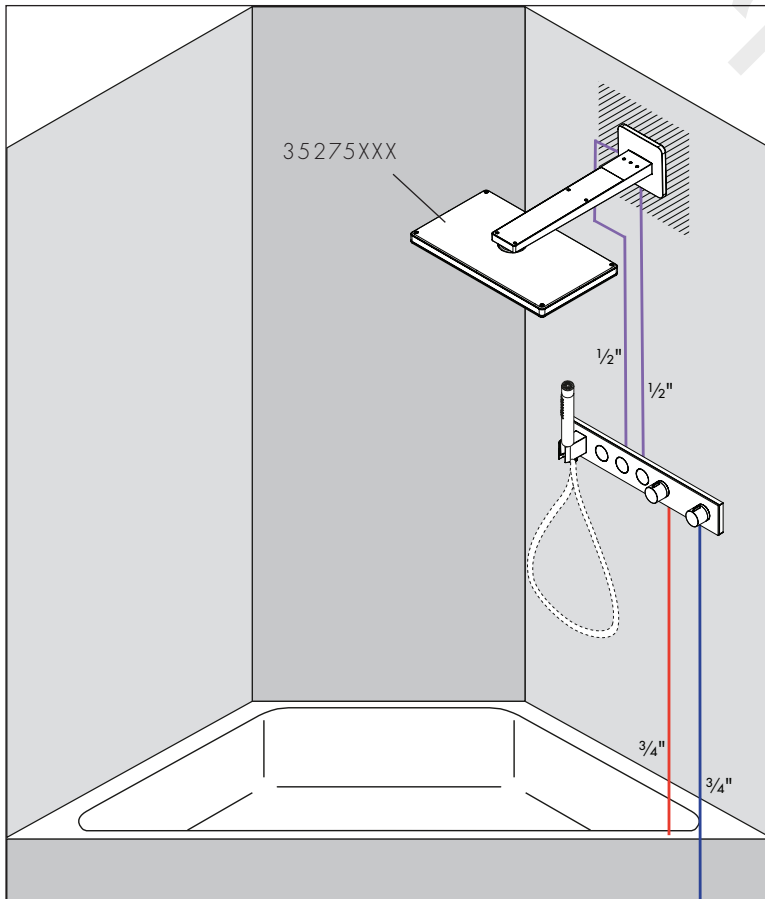

INSTALLATION / INSTALLATION / INSTALACIÓN

ENGLISH

FRANÇAIS

ESPAÑOL

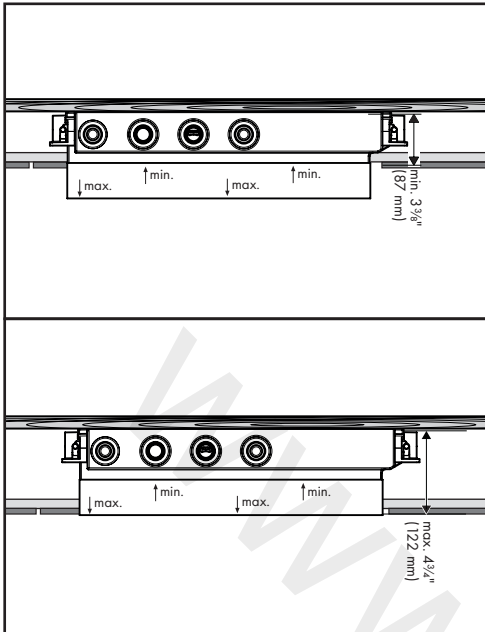

⚠ Install this valve so that the outside surface of the finished wall falls somewhere between the "min" and "max" markings on the installation box.

⚠ Installez ces vannes de façon à ce que la surface extérieure du mur fini se trouve entre les lignes « minimum » et « maximum » de la boîte d'installation.

⚠ Instale esta válvula de modo que la superficie exterior de la pared terminada quede entre las marcas "mín." y "máx." en la caja de instalación.

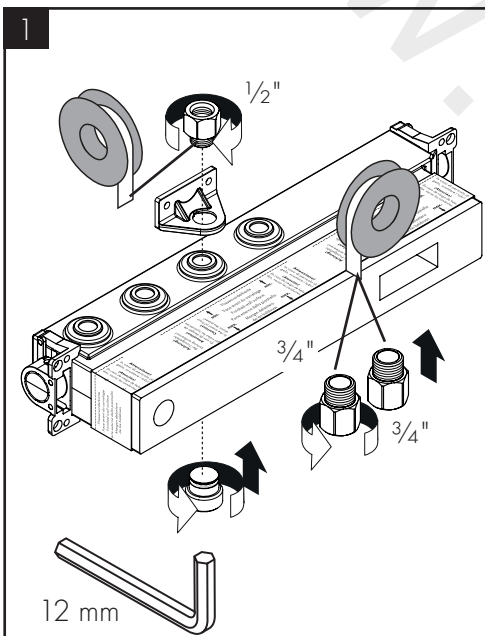

Wrap the threads on the 3/4" NPT adapters using plumber's thread tape. Install them on the hot and cold inlet ports.

Wrap the threads on the 1/2" NPT adapter(s) using plumber's thread tape. Install the adapter(s) on the outlet port(s).

Wrap the threads on the plug(s). Install the plug(s) on the unused outlet port(s).

Use one of the plugs to connect the support to the bottom of the rough.

Enroulez les filets sur les adaptateurs NPT 3/4 po à l'aide de ruban de plomberie. Installez-les sur les ports d'alimentation d'eau chaude et froide.

Enroulez les filets sur le ou les adaptateurs NPT 1/2 po à l'aide de ruban de plomberie. Installez le ou les adaptateurs dans le ou les orifices de sortie.

Enroulez les filets sur le ou les bouchons. Installez le ou les bouchons sur le ou les ports de sortie inutilisés.

Utilisez l'un des bouchons pour rattacher le support à la partie inférieure de la pièce intérieure.

Envuelva las rosas en los adaptadores NPT de 3/4" con cinta de plomero. Instálelas en los puertos de entrada de agua caliente y fría.

Envuelva las rosas en los adaptadores NPT de 1/2" con cinta de plomero. Instale los adaptadores en los puertos de salida.

Envuelva las rosas en el tapón. Instale los tapones en los puertos de salida no utilizados.

Use uno de los tapones para conectar el soporte a la parte inferior de la pieza interior.

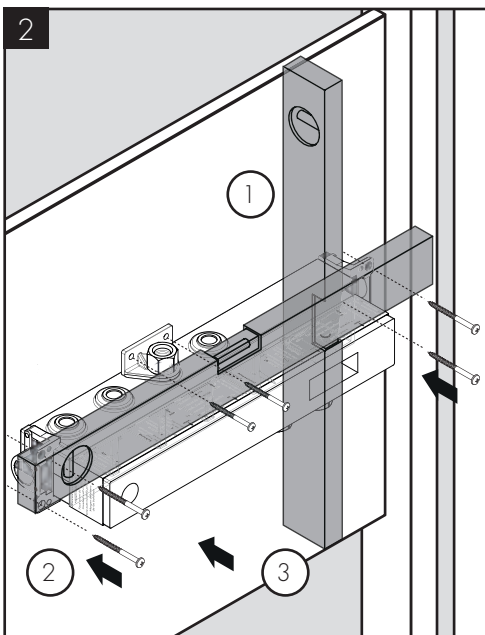

Screw the rough to the header board, making sure that it is level.

Vissez la pièce intérieure sur le panneau, en vous assurant qu'elle soit de niveau.

Atornille la pieza interior al panel de cabezal, asegurándose de que esté nivelado.

ENGLISH

FRANÇAIS

ESPAÑOL

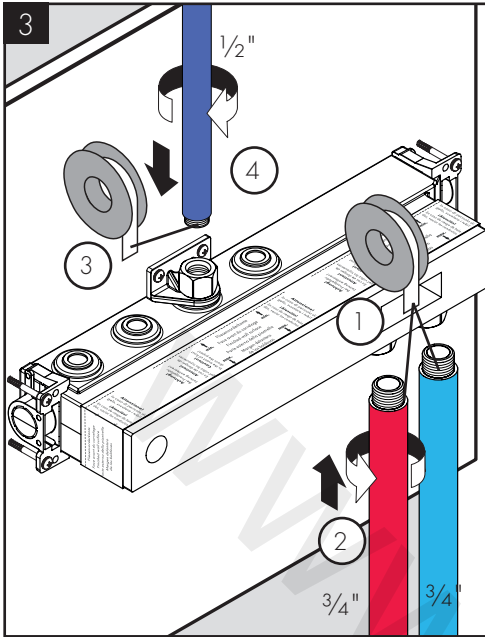

Install the 3/4" hot and cold supply lines.

Installez les conduites d'alimentation d'eau chaude et d'eau froide de 3/4 po.

Instale las tuberías de suministro de agua fría y caliente de 3/4".

⚠ To insure correct function of the thermostatic mixing valve, the hot must be on the left and the cold must be on the right.

⚠ Pour que le mitigeur thermostatique fonctionne correctement, la conduite d'alimentation de l'eau chaude doit être installée à gauche et la conduite d'eau froide doit être installée à droite.

⚠ Para garantizar que la válvula mezcladora termostática funcione correctamente, el suministro de agua caliente debe estar a la izquierda y el de agua fría a la derecha.

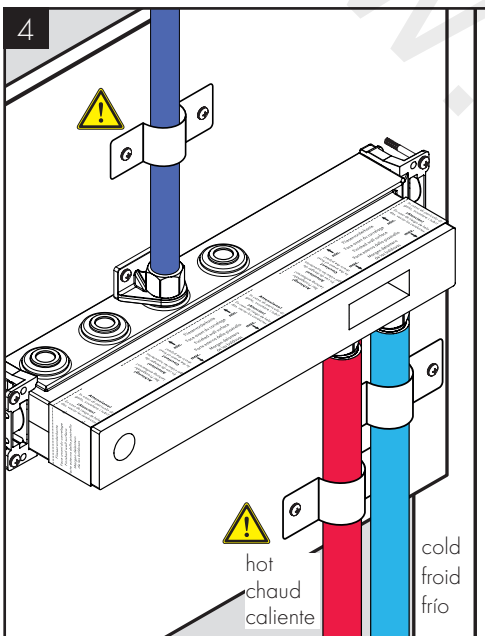

Make sure that the pipes are firmly secured.

Assurez-vous de bien fixer les conduites.

Asegúrese de que las tuberías estén firmemente sujetadas.

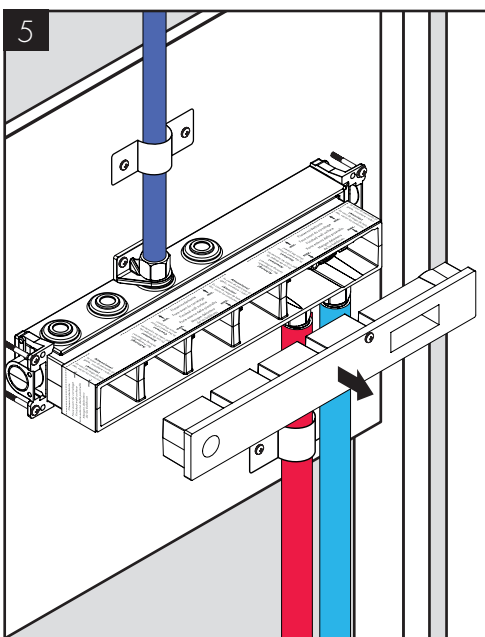

Remove the flush housing insert.

Retirez l'insert du compartiment affleurant.

Retire el inserto del alojamiento de descarga.

ENGLISH

FRANÇAIS

ESPAÑOL

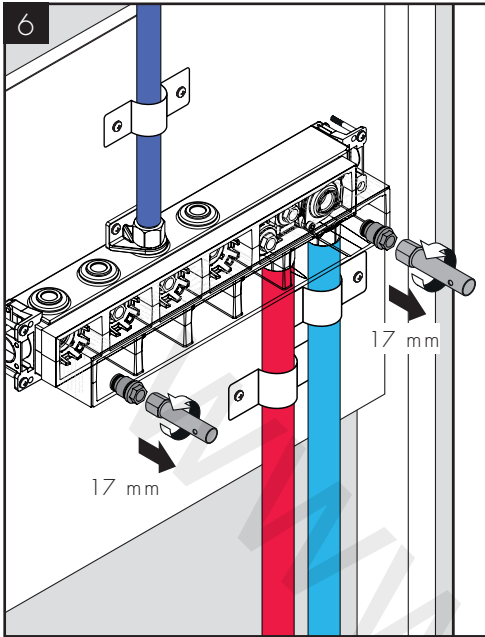

Remove the plugs from the thermostatic mixer housing and the handshower housing.

Retirez les bouchons du compartiment du mitigeur thermostatique et du compartiment de la douche.

Retire los tapones de la carcasa del mezclador termostático y de la carcasa de la ducha de mano.

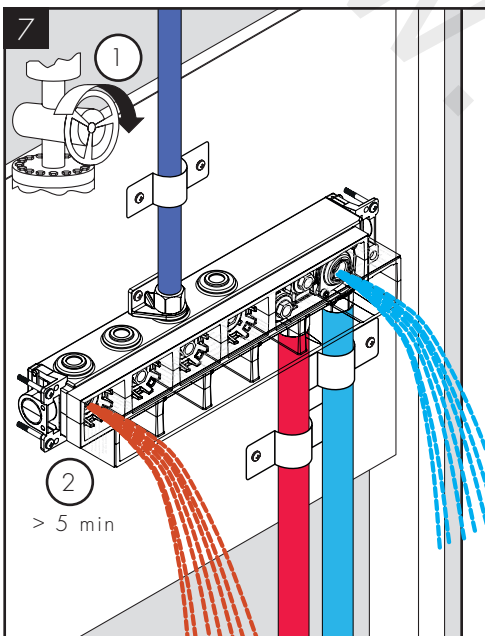

Turn the water on at the main.

Ouvrez l'eau à la valve principale.

Abra el paso del agua en la entrada del suministro.

Flush the hot and cold supplies for at least 5 minutes.

Rincez les conduites d'alimentation d'eau chaude et d'eau froide pendant au moins 5 minutes.

Purgue los suministros de agua caliente y agua fría durante al menos 5 minutos.

The cold supply will flush through the thermostatic mixer housing and the hot supply will flush through the handshower housing.

L'eau froide rincera le compartiment du mitigeur thermostatique tandis que l'eau chaude rincera le compartiment de la douche.

El suministro de agua fría se purga a través de la carcasa del mezclador termostático y el suministro de agua caliente mediante la carcasa de la ducha de mano.

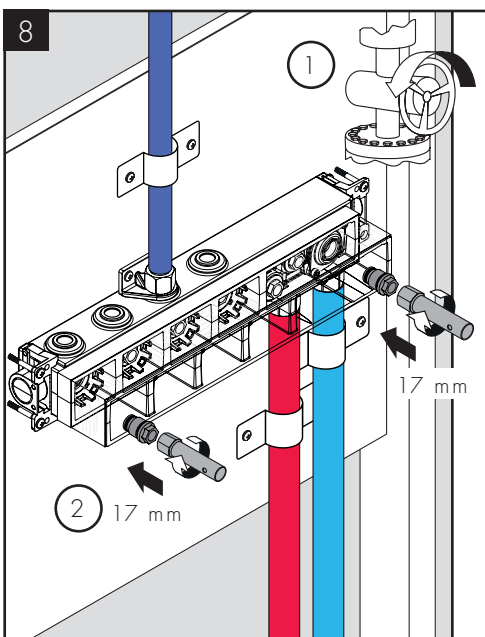

Turn the water off.

Fermez l'eau.

Cierre el suministro de agua.

Reinstall the plugs.

Réinstallez les bouchons.

Vuelva a instalar los tapones.

ENGLISH

FRANÇAIS

ESPAÑOL

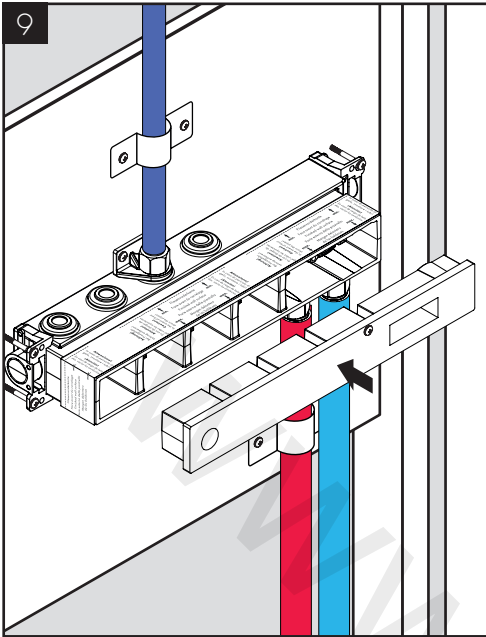

Install the insert.

Installez l'insert.

Instale el inserto.

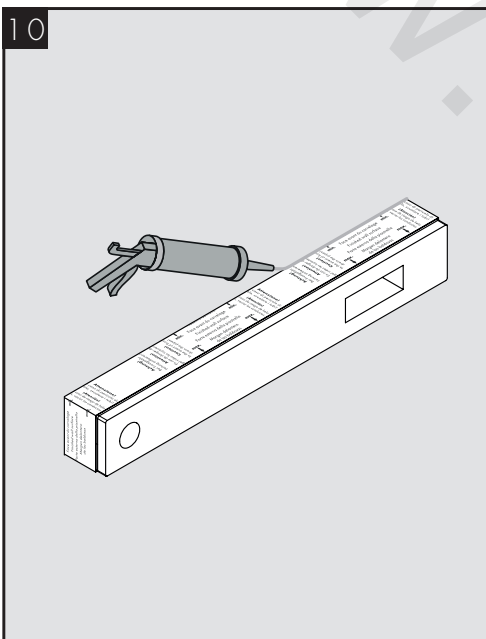

Install the sheetrock or green board up to the installation box.

Installez la plaque de plâtre ou la céramique jusqu'à la boîte d'installation.

Instale el estuco o panel verde hasta la caja de instalación.

Seal the wall around the installation box using waterproof sealant.

Scellez le mur autour du boîtier d'installation à l'aide d'un agent d'étanchéité.

Selle la pared alrededor de la caja de instalación con un sellador impermeable.

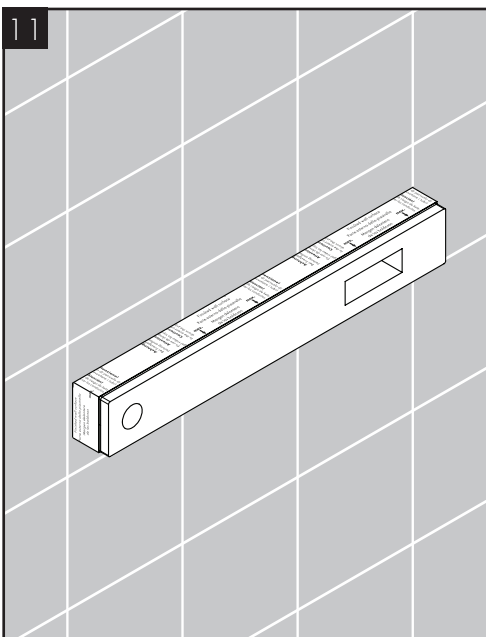

Install the finished wall surface up to the installation box.

Installez la surface finie du mur jusqu'à la boîte d'installation.

Instale la superficie de la pared terminada hasta la caja de instalación.

REPLACEMENT PARTS / PIÈCES DÉTACHÉES / REPUESTOS

AXOR Select
18310181
18311181

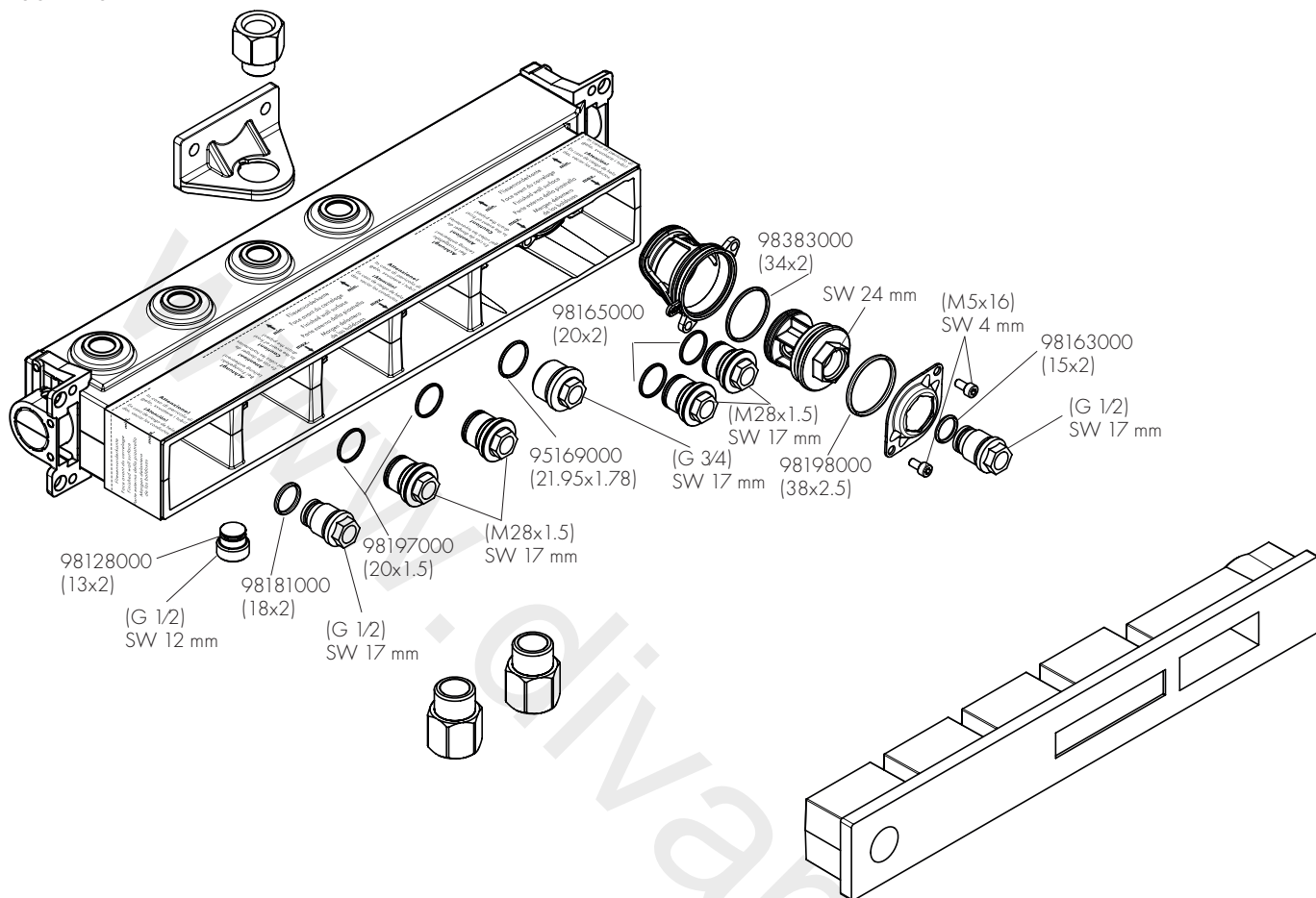

www.divapor.com

LIMITED CONSUMER WARRANTY

This warranty is limited to products manufactured by Hansgrohe, Inc. ("Hansgrohe") that are purchased by a consumer in the United States or Canada after March 1, 1996, and installed in either the United States or in Canada.

WHO IS COVERED BY THE WARRANTY

This limited warranty extends to the original purchaser only. This warranty is non-transferable. Hansgrohe neither assumes nor authorizes any person to create for it any other obligation or liability in connection with this product.

LENGTH OF WARRANTY

If you are a consumer who purchased the product for use primarily for personal, family or household purposes, this limited warranty starts on the date of purchase and extends for as long as you own the product and the home in which the product is originally installed. If you purchased the product for use primarily for any other purpose, including, without limitation, a commercial purpose, this limited warranty starts on the date of purchase and extends (i) for 1 year, with respect to Hansgrohe and Commercial products, and (ii) for 5 years, with respect to Axor products. The Rubbed Bronze finish is subject to a 3-year limited warranty starting on the date of purchase.

WHAT IS COVERED BY THE WARRANTY

This limited warranty covers only your Hansgrohe manufactured product. Hansgrohe warrants this product against defects in material or workmanship as follows:

Hansgrohe will replace at no charge for parts only or, at its option, replace any product or part of the product that proves defective because of improper workmanship and/or material, under normal installation, use, service and maintenance. If Hansgrohe is unable to provide a replacement and repair is not practical or cannot be made in timely fashion, Hansgrohe may elect to refund the purchase price in exchange for the return of the product. REPAIR OR REPLACEMENT (OR, IN LIMITED CIRCUMSTANCES, REFUND OF THE PURCHASE PRICE) AS PROVIDED UNDER THIS LIMITED WARRANTY IS THE EXCLUSIVE REMEDY OF THE PURCHASER.

WHAT IS NOT COVERED BY THE WARRANTY

- A. Conditions, malfunctions or damage not resulting from defects in material or workmanship.
- B. Conditions, malfunctions or damage resulting from (1) normal wear and tear, improper installation, improper maintenance, misuse, abuse, negligence, accident or alteration; (2) the use of abrasive or caustic cleaning agents or "no-rinse" cleaning products, or the use of the product in any manner contrary to the product instructions; or (3) conditions in the home such as excessive water pressure or corrosion.
- C. Labor and other expenses for disconnection, deinstallation, or return of the product for warranty service (including but not limited to proper packaging and shipping costs), or for installation or reinstallation of the product.

- D. Accessories, connected materials and products, or related products not manufactured by Hansgrohe.
- E. Any Hansgrohe or Axor product sold for display purposes.

HANSGROHE SHALL NOT BE LIABLE TO PURCHASER OR ANY OTHER PERSON FOR ANY INCIDENTAL, SPECIAL OR CONSEQUENTIAL DAMAGES, ARISING OUT OF BREACH OF THIS LIMITED WARRANTY.

Some provinces and some states do not allow the exclusion or limitation of incidental or consequential damages, so the above limitation or exclusion may not apply to you.

TO OBTAIN WARRANTY PARTS OR INFORMATION

Contact your Hansgrohe retailer, or contact Technical Service at:

Hansgrohe, Inc.
1492 Bluegrass Lakes Parkway
Alpharetta, GA 30004
Toll-free 800-334-0455

In requesting warranty service, you will need to provide:

1. The sales receipt or other evidence of the date and place of purchase.
2. A description of the problem.
3. Delivery of the product or the defective part, postage prepaid and carefully packed and insured, to:

Hansgrohe, Inc.
1492 Bluegrass Lakes Parkway
Alpharetta, GA 30004
Toll-free 800-334-0455

When warranty service is completed, any repaired or replacement product or part will be returned to you postage prepaid. REVISED MAY 1, 2016.

PRODUCT INSTRUCTIONS AND QUESTIONS

Upon purchase or prior to installation, please carefully inspect your Hansgrohe product for any damage or visible defect. Prior to installing, always carefully study the enclosed instructions on the proper installation and the care and maintenance of this product. If you have questions at any time about the use, installation or performance of your Hansgrohe product, or this warranty, please write us or call us toll-free at 800-334-0455.

AXOR

www.divapor.com

AXOR / Hansgrohe, Inc.
1490 Bluegrass Lakes Parkway
Alpharetta, GA 30004

Tel. 800-334-0455
Fax 770-889-1783

axor-design.com