

AXOR

DE / Gebrauchsanleitung / Montageanleitung	02
FR / Mode d'emploi / Instructions de montage	03
EN / Instructions for use / Assembly instructions	04
IT / Istruzioni per l'uso / Istruzioni per Installazione	05
ES / Modo de empleo / Instrucciones de montaje	06
NL / Gebruiksaanwijzing / Handleiding	07
DK / Brugsanvisning / Monteringsvejledning	08
PT / Instruções para uso / Manual de Instalação	09
PL / Instrukcja obsługi / Instrukcja montażu	10
CS / Návod k použití / Montážní návod	11
SK / Návod na použitie / Montážny návod	12
ZH / 用户手册 / 组装说明	13
RU / Руководство пользователя / Инструкция по монтажу	14
FI / Käyttöohje / Asennusohje	15
SV / Bruksanvisning / Monteringsanvisning	16
LT / Vartotojo instrukcija / Montavimo instrukcijos	17
HR / Upute za uporabu / Uputstva za instalaciju	18
RO / Manual de utilizare / Instrucțiuni de montare	19
EL / Οδηγίες χρήσης / Οδηγία συναρμολόγησης	20
SL / Navodilo za uporabo / Navodila za montažo	21
ET / Kasutusjuhend / Paigaldusjuhend	22
LV / Lietošanas pamācība / Montāžas instrukcija	23
SR / Uputstvo za upotrebu / Uputstvo za montažu	24
NO / Bruksanvisning / Montasjeveiledning	25
BG / Инструкция за употреба / Ръководство за монтаж	26
JP / 取扱説明書 / 施工説明書	27
SQ / Udhëzuesi i përdorimit / Udhëzime rreth montimit	28
AR / دليل الاستخدام / تعليمات التجميع	29
TR / Kullanım kılavuzu / Montaj kılavuzu	30
HU / Használati útmutató / Szerelési útmutató	32

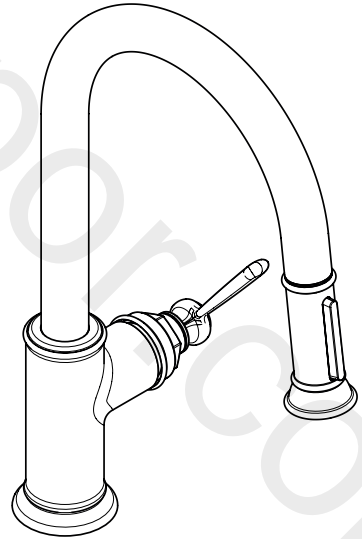

AXOR Montreux 180
16581XXX

INSTALLATION

⚠ SICHERHEITSHINWEISE

- ⚠ Bei der Montage müssen zur Vermeidung von Quetsch- und Schnittverletzungen Handschuhe getragen werden.
- ⚠ Große Druckunterschiede zwischen den Kalt- und Warmwasseranschlüssen müssen ausgeglichen werden.

MONTAGEHINWEISE

- / Vor der Montage muss das Produkt auf Transportschäden untersucht werden. Nach dem Einbau werden keine Transport- oder Oberflächenschäden anerkannt.
- / Die Leitungen und die Armatur müssen nach den gültigen Normen montiert, gespült und geprüft werden.
- / Die in den Ländern jeweils gültigen Installationsrichtlinien sind einzuhalten.

TECHNISCHE DATEN

Betriebsdruck: max. 1 MPa
 Empfohlener Betriebsdruck: 0,1 - 0,5 MPa
 Prüfdruck: 1,6 MPa
 (1 MPa = 10 bar = 147 PSI)

Heißwassertemperatur: max. 60°C
 Thermische Desinfektion: 70°C / 4 min

- / Eigensicher gegen Rückfließen
- / Das Produkt ist ausschließlich für Trinkwasser konzipiert!

SYMBOLERKLÄRUNG

Kein essigsäurehaltiges Silikon verwenden!



JUSTIERUNG (siehe Seite 38)

Einstellen der Warmwasserbegrenzung. In Verbindung mit Durchlauferhitzern ist eine Warmwassersperre nicht zu empfehlen.



WARTUNG (siehe Seite 41)

Rückflussverhinderer müssen gemäß EN 806-5 regelmäßig in Übereinstimmung mit nationalen oder regionalen Bestimmungen auf ihre Funktion geprüft werden (mindestens einmal jährlich).



MASS E (siehe Seite 42)



DURCHFLUSSDIAGRAMM
(siehe Seite 42)



SERVICETEILE (siehe Seite 43)

XXX = Farbcodierung
 000 = Chrom
 020 = Polished Chrome
 130 = Polished Bronze
 140 = Brushed Bronze
 250 = Brushed Gold-Optic
 260 = Brushed Chrome
 300 = Polished Redgold
 310 = Brushed Redgold
 330 = Polished Black Chrome
 340 = Brushed Black Chrome
 800 = Stainless Steel Optic
 820 = Brushed Nickel
 830 = Polished Nickel
 930 = Polished Brass
 950 = Brushed Brass
 990 = Polished Gold-Optic



REINIGUNG (siehe Seite 40)



BEDIENUNG (siehe Seite 39)

Hansgrohe empfiehlt, morgens oder nach längeren Stagnationszeiten den ersten halben Liter nicht als Trinkwasser zu verwenden.



PRÜFZEICHEN (siehe Seite 44)

STÖRUNG	URSACHE	ABHILFE
/ Wenig Wasser	/ Luftsprudler verkalkt, verschmutzt	/ Luftsprudler reinigen/austauschen
/ Armatur schwergängig	/ Kartusche defekt, verkalkt	/ Kartusche austauschen
/ Armatur tropft	/ Kartusche defekt	/ Kartusche austauschen
/ Wasseraustritt am Befestigungsschaft	/ Anschlusschläuche nicht ganz in den Grundkörper eingeschraubt	/ Anschlusschläuche von Hand festziehen
	/ O-Ring am Anschlusschlauch defekt	/ O-Ring austauschen
/ Zu niedrige Warmwassertemperatur	/ Warmwasserbegrenzung falsch eingestellt	/ Warmwasserbegrenzung einstellen



△ CONSIGNES DE SÉCURITÉ

- △ Lors du montage, porter des gants de protection pour éviter toute blessure par écrasement ou coupure.
- △ Il est conseillé d'équilibrer les pressions de l'eau chaude et froide.

INSTRUCTIONS POUR LE MONTAGE

- / Avant son montage, s'assurer que le produit n'a subi aucun dommage pendant le transport. Après le montage, tout dommage de transport ou de surface ne pourra pas être reconnu.
- / Les conduites et la robinetterie doivent être montés, rincés et contrôlés selon les normes en vigueur.
- / Les directives d'installation en vigueur dans le pays concerné doivent être respectées.

INFORMATIONS TECHNIQUES

Pression de service autorisée: max. 1 MPa
 Pression de service conseillée: 0,1 - 0,5 MPa
 Pression maximum de contrôle: 1,6 MPa
 (1 MPa = 10 bar = 147 PSI)

Température d'eau chaude: max. 60°C
 Désinfection thermique: 70°C / 4 min

- / Avec dispositif anti-retour
- / Le produit est exclusivement conçu pour de l'eau potable!

DESCRIPTION DU SYMBOLE



Ne pas utiliser de silicone contenant de l'acide acétique!



ETALONNAGE (voir pages 38)

Réglage de la limitation d'eau chaude. En liaison avec les chauffe-eau, un blocage de l'eau chaude n'est pas recommandable.



ENTRETIEN (voir pages 41)

Les clapets anti-retour doivent être examinés régulièrement conformément à la norme EN 806-5 ou conformément aux dispositions nationales ou régionales quant à leur fonction (au moins une fois par an).



DIMENSIONS (voir pages 42)



DIAGRAMME DU DÉBIT (voir pages 42)



PIÈCES DÉTACHÉES (voir pages 43)

XXX = Couleurs
 000 = Chromé
 020 = Polished Chrome
 130 = Polished Bronze
 140 = Brushed Bronze
 250 = Brushed Gold-Optic
 260 = Brushed Chrome
 300 = Polished Redgold
 310 = Brushed Redgold
 330 = Polished Black Chrome
 340 = Brushed Black Chrome
 800 = Stainless Steel Optic
 820 = Brushed Nickel
 830 = Polished Nickel
 930 = Polished Brass
 950 = Brushed Brass
 990 = Polished Gold-Optic



NETTOYAGE (voir pages 40)



INSTRUCTIONS DE SERVICE (voir pages 39)

Hansgrohe recommande de ne pas utiliser le premier demi-litre le matin ou après une période de stagnation prolongée.



CLASSIFICATION ACOUSTIQUE ET DÉBIT (voir pages 44)

DYSFONCTIONNEMENT	ORIGINE	SOLUTION
/ Pas assez d'eau	/ aérateur entartré ou encrassé	/ Nettoyer l'aérateur ou le changer éventuellement
/ Dureté de fonctionnement	/ Cartouche défectueuse, entartrée	/ Changer la cartouche
/ Le mitigeur goutte	/ Cartouche défectueuse	/ Changer la cartouche
/ Fuite à la fixation sous le mitigeur	/ Les flexibles de raccordement ne sont pas correctement visser dans le corps.	/ Resserer le flexible à la main.
	/ Joint torique sous les flexible de raccords défectueux	/ Changer le joint torique
/ Température d'eau chaude trop basse, pas d'eau froide	/ Limiteur de température mal positionné	/ Positionner le limiteur de température

MONTAGE (voir pages 34)



SAFETY NOTES

- △ Gloves should be worn during installation to prevent crushing and cutting injuries.
- △ The hot and cold supplies must be of equal pressures.

INSTALLATION INSTRUCTIONS

- / Prior to installation, inspect the product for transport damages. After it has been installed, no transport or surface damage will be honoured.
- / The pipes and the fixture must be installed, flushed and tested as per the applicable standards.
- / The plumbing codes applicable in the respective countries must be observed.

TECHNICAL DATA

Operating pressure: max. 1 MPa
 Recommended operating pressure: 0,1 - 0,5 MPa
 Test pressure: 1,6 MPa
 (1 MPa = 10 bar = 147 PSI)

Hot water temperature: max. 60°C
 Thermal disinfection: 70°C / 4 min

- / Safety against backflow
- / The product is exclusively designed for drinking water!

SYMBOL DESCRIPTION

Do not use silicone containing acetic acid!



ADJUSTMENT (see page 38)

To adjust the hot water limiter. Using a hot water limiter in combination with a continuous flow water heater is not recommended.



MAINTENANCE (see page 41)

The check valves must be checked regularly according to EN 806-5 in accordance with national or regional regulations (at least once a year).

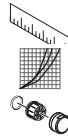

DIMENSIONS (see page 42)

FLOW DIAGRAM (see page 42)

SPARE PARTS (see page 43)

XXX = Colors
 000 = Chrome Plated
 020 = Polished Chrome
 130 = Polished Bronze
 140 = Brushed Bronze
 250 = Brushed Gold-Optic
 260 = Brushed Chrome
 300 = Polished Redgold
 310 = Brushed Redgold
 330 = Polished Black Chrome
 340 = Brushed Black Chrome
 800 = Stainless Steel Optic
 820 = Brushed Nickel
 830 = Polished Nickel
 930 = Polished Brass
 950 = Brushed Brass
 990 = Polished Gold-Optic



CLEANING (see page 40)



OPERATION (see page 39)

Hansgrohe recommends not to use as drinking water the first half liter of water drawn in the morning or after a prolonged period of non-use.



TEST CERTIFICATE (see page 44)

FAULT	CAUSE	REMEDY
/ Insufficient water	/ Aerator calcified, dirty	/ Clean aerator, replace as necessary
/ Mixer stiff	/ Cartridge defective, calcified	/ Exchange cartridge
/ Mixer dripping	/ Cartridge defective	/ Exchange cartridge
/ Water escaping at the threaded base	/ connection hoses not completely screwed into basic body	/ Tighten connection hoses by hand
	/ O-ring at the connection hose defective.	/ Exchange O-ring
/ Hot water temperature too low	/ Hot water limiter incorrectly set	/ Set hot water limiter



△ INDICAZIONI SULLA SICUREZZA

- △ Durante il montaggio, per evitare ferite da schiacciamento e da taglio bisogna indossare guanti protettivi.
- △ Attenzione! Compensare le differenze di pressione tra i collegamenti dell'acqua fredda e dell'acqua calda.

ISTRUZIONI PER IL MONTAGGIO

- / Prima del montaggio è necessario controllare che non ci siano stati danni durante il trasporto. Una volta eseguito il montaggio, non verranno riconosciuti eventuali danni di trasporto o delle superfici.
- / Montare, lavare e controllare tubature e rubinetteria rispettando le norme correnti.
- / Vanno rispettate le direttive di installazione nazionali vigenti nel rispettivo paese.

DATI TECNICI

Pressione d'uso:	max. 1 MPa
Pressione d'uso consigliata:	0,1 - 0,5 MPa
Pressione di prova:	1,6 MPa (1 MPa = 10 bar = 147 PSI)
Temperatura dell'acqua calda:	max. 60°C
Disinfezione termica:	70°C / 4 min

- / Sicurezza antiriflusso
- / Il prodotto è concepito esclusivamente per acqua potabile!

DESCRIZIONE SIMBOLO



Non utilizzare silicone contenente acido acetico!



TARATURA (vedi pagg. 38)

Regolazione del limitatore di erogazione d'acqua calda. Un limitatore di erogazione di acqua calda in combinazione con le caldaie istantanee non è consigliabile.



MANUTENZIONE (vedi pagg. 41)

La valvola di non ritorno deve essere controllata regolarmente come da EN 806-5, secondo le normative nazionali e regionali (almeno una volta all'anno).



INGOMBRI (vedi pagg. 42)



DIAGRAMMA FLUSSO
(vedi pagg. 42)



PARTI DI RICAMBIO
(vedi pagg. 43)

XXX =	Trattamento
000 =	Cromato
020 =	Polished Chrome
130 =	Polished Bronze
140 =	Brushed Bronze
250 =	Brushed Gold-Optic
260 =	Brushed Chrome
300 =	Polished Redgold
310 =	Brushed Redgold
330 =	Polished Black Chrome
340 =	Brushed Black Chrome
800 =	Stainless Steel Optic
820 =	Brushed Nickel
830 =	Polished Nickel
930 =	Polished Brass
950 =	Brushed Brass
990 =	Polished Gold-Optic



PULITURA (vedi pagg. 40)



PROCEDURA (vedi pagg. 39)

Hansgrohe raccomanda, di mattina oppure dopo lunghi tempi di stagnazione, di non utilizzare il primo mezzo litro come acqua potabile.



SEGNO DI VERIFICA
(vedi pagg. 44)

PROBLEMA	POSSIBILE CAUSA	RIMEDIO
/ Scarsità d'acqua	/ Rompigetto difettosa, piena di calcare	/ Pulire oppure sostituire il rompigetto
/ Miscelatore duro	/ Cartuccia difettosa	/ Sostituire la cartuccia
/ Miscelatore gocciola	/ Cartuccia difettosa	/ Sostituire la cartuccia
/ Perdita di acqua al set di fissaggio	/ I raccordi dei flessibili avvitati male nel corpo incasso	/ Avvitare i raccordi flessibili a mano
	/ O-ring al raccordo flessibile difettoso	/ Sostituire l'o-ring
/ Temperatura dell'acqua calda	/ Limitazione dell'acqua calda regolata male	/ Regolare la limitazione dell'acqua calda

MONTAGGIO (vedi pagg. 34)



INDICACIONES DE SEGURIDAD

- ⚠ Durante el montaje deben utilizarse guantes para evitar heridas por aplastamiento o corte.
- ⚠ Grandes diferencias de presión en servicio entre agua fría y agua caliente deben equilibrarse.

INDICACIONES PARA EL MONTAJE

- / Antes del montaje se debe examinarse el producto contra daños de transporte. Después de la instalación no se reconoce ningún daño de transporte o de superficie.
- / Los conductos y la grifería deben montarse, lavarse y comprobarse según las normas vigentes.
- / Es obligatorio el cumplimiento de las directrices de instalación vigentes en el país respectivo.

DATOS TÉCNICOS

Presión en servicio:	max. 1 MPa
Presión recomendada en servicio:	0,1 - 0,5 MPa
Presión de prueba:	1,6 MPa (1 MPa = 10 bar = 147 PSI)
Temperatura del agua caliente:	max. 60°C
Desinfección térmica:	70°C / 4 min

- / Seguro contra el retorno
- / El producto ha sido concebido exclusivamente para agua potable.

DESCRIPCIÓN DE SÍMBOLOS

No utilizar silicona que contiene ácido acético

AJUSTE (ver página 38)

Ajuste del límite de agua caliente. En combinación con calentadores continuos no es recomendable utilizar un bloqueo de agua caliente.



MANTENIMIENTO (ver página 41)

Las válvulas anti-retorno tienen que ser controladas regularmente según la norma EN 806-5, en acuerdo con las regulaciones nacionales o regionales (una vez al año, por lo menos).



DIMENSIONES (ver página 42)

DIAGRAMA DE CIRCULACIÓN (ver página 42)



REPUESTOS (ver página 43)

XXX	= Acabados
000	= Cromado
020	= Polished Chrome
130	= Polished Bronze
140	= Brushed Bronze
250	= Brushed Gold-Optic
260	= Brushed Chrome
300	= Polished Redgold
310	= Brushed Redgold
330	= Polished Black Chrome
340	= Brushed Black Chrome
800	= Stainless Steel Optic
820	= Brushed Nickel
830	= Polished Nickel
930	= Polished Brass
950	= Brushed Brass
990	= Polished Gold-Optic



LIMPIAR (ver página 40)



MANEJO (ver página 39)

Hansgrohe recomienda no utilizar el primer medio litro como agua potable por las mañanas o tras un largo periodo de inactividad.



MARCA DE VERIFICACIÓN (ver página 44)

PROBLEMA	CAUSA	SOLUCIÓN
/ Sale poca agua	/ Aireador con cal o sucio	/ limpiar/cambiar aireador
/ Manecilla va dura	/ cartucho dañado	/ cambiar el cartucho
/ Grifo pierde agua	/ cartucho dañado	/ cambiar el cartucho
/ Pérdida de agua en el set de fijación	/ Conexión flexible mal atornillada al cuerpo del caño.	/ Apretar a mano la conexión flexible
	/ Daños en la junta de la conexión flexible	/ cambiar juntas
/ Temperatura del agua caliente demasiado baja	/ tope de agua caliente mal	/ ajustar tope

MONTAJE (ver página 34)



△ VEILIGHEIDSINSTRUCTIES

- △ Bij de montage moeten ter voorkoming van knel- en snijwonden handschoenen worden gedragen.
- △ Grote drukverschillen tussen de koud- en warmwater-toevoer dienen vermeden te worden.

MONTAGE-INSTRUCTIES

- / Vóór de montage moet het product gecontroleerd worden op transportschade. Na de inbouw wordt geen transport- of oppervlakteschade meer aanvaard.
- / De leidingen en armaturen moeten gemonteerd, gespoeld en gecontroleerd worden volgens de geldige normen.
- / De in de overeenkomstige landen geldende installatie-richtlijnen moeten nageleefd worden.

TECHNISCHE GEGEVENS

Werkdruk: max.	max. 1 MPa
Aanbevolen werkdruk:	0,1 - 0,5 MPa
Getest bij:	1,6 MPa
	(1 MPa = 10 bar = 147 PSI)
Temperatuur warm water:	max. 60°C
Thermische desinfectie:	70°C / 4 min

- / Beveiligd tegen terugstromen
- / Het product is uitsluitend ontworpen voor drinkwater!

SYMBOOLBESCHRIJVING



Gebruik geen zuurhoudende silicone!

INSTELLEN (zie blz. 38)

Instellen van de warmwaterbegrenzing. In combinatie met een doorstroomer is een warmwaterblokkering niet aanbevelenswaardig.



ONDERHOUD (zie blz. 41)

Keerleppen moeten volgens EN 806-5 regelmatig en volgens plaatselijk geldende eisen

op het functioneren gecontroleerd worden. (Tenminste een keer per jaar)

MATEN (zie blz. 42)



DOORSTROOMDIAGRAM (zie blz. 42)



SERVICE ONDERDELEN (zie blz. 43)

XXX = Kleuren
000 = Verchroomd
020 = Polished Chrome
130 = Polished Bronze
140 = Brushed Bronze
250 = Brushed Gold-Optic
260 = Brushed Chrome
300 = Polished Redgold
310 = Brushed Redgold
330 = Polished Black Chrome
340 = Brushed Black Chrome
800 = Stainless Steel Optic
820 = Brushed Nickel
830 = Polished Nickel
930 = Polished Brass
950 = Brushed Brass
990 = Polished Gold-Optic



REINIGEN (zie blz. 40)



BEDIENING (zie blz. 39)

Hansgrohe raadt aan om 's morgens na langere stagnatietijden de eerste halve liter niet als drinkwater te gebruiken.



KEURMERK (zie blz. 44)

STORING

- / Weinig water
- / Bediening zwaar
- / Mengkraan lekt
- / Lekkage op montageschacht

OORZAAK

- / Perlator verstopt
- / Kardoes defect of verkalkt
- / Kardoes defect
- / Aansluitslangen niet geheel in kraan-huis vastgedraaid
- / O-ring van aansluitslang defect
- / Heetwaterbegrenzer verkeerd ingesteld

OPLOSSING

- / Perlator reinigen/uitwisselen
- / Kardoes uitwisselen
- / Kardoes uitwisselen
- / Aansluitslangen handvast aandraaien
- / O-ring uitwisselen
- / Heetwaterbegrenzer instellen

MONTAGE (zie blz. 34)



△ SIKKERHEDSANVISNINGER

- △ Ved monteringen skal der bruges handsker for at undgå kvæstelser og snitsår.
- △ Større trykforskelle mellem koldt og varmt vand bør udjævnes.

MONTERINGSANVISNINGER

- / Før monteringen skal produktet kontrolleres for transportskader. Efter monteringen godkendes transportskader eller skader på overfladen ikke længere.
- / Ledningerne og armaturerne skal monteres, skylles og kontrolleres iht. de gældende standarder.
- / Installationsbestemmelserne, der gælder i det enkelte land, skal overholdes.

TEKNISKE DATA

Driftstryk:	max. 1 MPa
Anbefalet driftstryk:	0,1 - 0,5 MPa
Prøvetryk:	1,6 MPa
	(1 MPa = 10 bar = 147 PSI)
Varmtvandstemperatur:	max. 60°C
Termisk desinfektion:	70°C / 4 min

- / Med indbygget kontraventil
- / Produktet er udelukkende beregnet til drikkevand!

SYMBOLBESKRIVELSE

 Der må ikke benyttes eddikesyreholdig silikone!

FORINDSTILLING (se s. 38)

Indstilling af varmvandsbegrænsningen. I forbindelse med gennemstrømningsvandvarmere anbefaler vi ikke en varmvandsspærre.

 SERVICE (se s. 41)

Ifølge EN 806-5 skal gennemstrømningsbegrænsere i overensstemmelse med nationale regler afprøves regelmæssigt (mindst en gang om året).

 MÅLENE (se s. 42)

 GENNEMSTRØMNINGSDIAGRAM (se s. 42)

 RESERVEDELE (se s. 43)

XXX = Overflade
 000 = Krom
 020 = Polished Chrome
 130 = Polished Bronze
 140 = Brushed Bronze
 250 = Brushed Gold-Optic
 260 = Brushed Chrome
 300 = Polished Redgold
 310 = Brushed Redgold
 330 = Polished Black Chrome
 340 = Brushed Black Chrome
 800 = Stainless Steel Optic
 820 = Brushed Nickel
 830 = Polished Nickel
 930 = Polished Brass
 950 = Brushed Brass
 990 = Polished Gold-Optic

 RENGØRING (se s. 40)

 BRUGSANVISNING (se s. 39)

Hansgrohe anbefaler at den første halve liter om morgenen eller efter længere stagneringstider ikke anvendes som drikkevand.

 GODKENDELSE (se s. 44)

FEJL	ÅRSAG	HJÆLP
/ For lidt vand	/ Tilkalket/snavset perlator	/ Rengør/udskift perlator
/ Grebet går trægt	/ Kartusche defekt, tilkalket	/ Udskift kartusche
/ Armaturet drypper	/ Defekt kartusche	/ Udskift kartusche
/ Armaturet er utæt ved befæstelsesdelene	/ Tilslutningsslangerne er ikke skruet korrekt op i armaturet.	/ Med håndkraft skures tilslutningsslangen strammere på.
	/ Defekt o-ring på tilslutningslange	/ Udskift o-ring
/ For lav varmtvands-temperatur	/ Varmtvandsbegrænsningen er forkert indstillet	/ Indstil varmtvandsbegrænsningen



⚠ AVISOS DE SEGURANÇA

- ⚠ Durante a montagem devem ser utilizadas luvas de protecção, de modo a evitar ferimentos resultantes de entalamentos e de cortes.
- ⚠ Grandes diferenças entre as pressões das águas quente e fria devem ser compensadas.

AVISOS DE MONTAGEM

- / Antes da montagem deve-se controlar o produto relativamente a danos de transporte. Após a montagem não são aceites quaisquer danos de transporte ou de superfície.
- / As tubagens e a torneira têm que ser montadas, enxaguadas e verificadas de acordo com as normas em vigor.
- / A prescrições de instalação válidas nos respetivos países devem ser respeitadas.

DADOS TÉCNICOS

Pressão de funcionamento:	max. 1 MPa
Pressão de func. recomendada:	0,1 - 0,5 MPa
Pressão testada:	1,6 MPa
	(1 MPa = 10 bar = 147 PSI)
Temperatura da água quente:	max. 60°C
Desinfecção térmica:	70°C / 4 min

- / Função anti-retorno e anti-vácuo
- / Este produto foi única e exclusivamente concebido para água potável!

DESCRIÇÃO DO SÍMBOLO



Não utilizar silicone que contenha ácido acético!



AFINAÇÃO (ver página 38)

Ajuste do limitador de água quente. Em combinação com um esquentador, não é



recomendável o uso de um bloqueio de água quente.

MANUTENÇÃO (ver página 41)

As válvulas anti-retorno devem ser verificadas regularmente de acordo com a EN 806-5 segundo os regulamentos nacionais ou regionais (pelo menos uma vez por ano).

MEDIDAS (ver página 42)



FLUXOGRAMA (ver página 42)



PEÇAS DE SUBSTITUIÇÃO

(ver página 43)

- XXX = Acabamentos
- 000 = Cromado
- 020 = Polished Chrome
- 130 = Polished Bronze
- 140 = Brushed Bronze
- 250 = Brushed Gold-Optic
- 260 = Brushed Chrome
- 300 = Polished Redgold
- 310 = Brushed Redgold
- 330 = Polished Black Chrome
- 340 = Brushed Black Chrome
- 800 = Stainless Steel Optic
- 820 = Brushed Nickel
- 830 = Polished Nickel
- 930 = Polished Brass
- 950 = Brushed Brass
- 990 = Polished Gold-Optic



LIMPEZA (ver página 40)



FUNCIONAMENTO (ver página 39)

A Hansgrohe recomenda a não utilização do primeiro meio litro de água, de manhã ou após longas paragens, para fins de consumo.



MARCA DE CONTROLO (ver página 44)

FALHA	CAUSA	SOLUÇÃO
/ Água insuficiente	/ Emulsor sujo	/ Limpar/trocar o emulsor
/ Misturadora perra	/ Cartucho defeituoso, calcificado	/ Substituir o cartucho
/ Misturadora a pingar	/ Cartucho defeituoso	/ Substituir o cartucho
/ Perde água pela base roscada	/ Tubos de ligação não estão completamente enroscados	/ Apertar os tubos de ligação à mão
	/ O-ring dos tubo de ligação defeituoso	/ Trocar o-ring
/ Temperatura da água quente muito baixa	/ O limitador de temperatura está incorretamente colocado	/ Regular o limitador de temperatura

MONTAGEM (ver página 34)



△ WSKAZÓWKI BEZPIECZEŃSTWA

- △ Aby uniknąć zranień na skutek zgniecenia lub przecięcia, podczas montażu należy nosić rękawice ochronne.
- △ Znaczne różnice ciśnień na dopływach ciepłej i zimnej wody muszą zostać wyrównane.

WSKAZÓWKI MONTAŻOWE

- / Przed montażem należy skontrolować produkt pod kątem szkód transportowych. Po montażu nie widać żadnych szkód transportowych ani szkód na powierzchni.
- / Przewody i armatura muszą być montowane, płukane i kontrolowane według obowiązujących norm.
- / Należy przestrzegać wytycznych instalacyjnych obowiązujących w danym kraju.

DANE TECHNICZNE

Ciśnienie robocze:	maks. 1 MPa
Zalecane ciśnienie robocze:	0,1 - 0,5 MPa
Ciśnienie próbne:	1,6 MPa
	(1 MPa = 10 bary = 147 PSI)
Temperatura wody gorącej:	maks. 60°C
Dezynfekcja termiczna:	70°C / 4 min

- / Zabezpieczony przed przepływem zwrotnym
- / Produkt przeznaczony wyłącznie do wody pitnej!

OPIS SYMBOLU



Nie stosować silikonów zawierających kwas octowy!



USTAWIANIE (patrz strona 38)

Ustawianie ogranicznika ciepłej wody.
Używanie ogranicznika temperatury wody w połączeniu z przepływowym podgrzewaczem wody nie jest zalecane.



KONSERWACJA (patrz strona 41)

Zgodnie z normą EN 806-5, krajowymi i miejscowymi przepisami, działanie zabezpieczeń przed przepływem zwrotnym musi być kontrolowane (przynajmniej raz w roku).



WYMIARY (patrz strona 42)



SCHEMAT PRZEPŁYWU (patrz strona 42)



CZĘŚCI SERWISOWE (patrz strona 43)

XXX = Kody kolorów
000 = Chrom
020 = Polished Chrome
130 = Polished Bronze
140 = Brushed Bronze
250 = Brushed Gold-Optic
260 = Brushed Chrome
300 = Polished Redgold
310 = Brushed Redgold
330 = Polished Black Chrome
340 = Brushed Black Chrome
800 = Stainless Steel Optic
820 = Brushed Nickel
830 = Polished Nickel
930 = Polished Brass
950 = Brushed Brass
990 = Polished Gold-Optic



CZYSZCZENIE (patrz strona 40)



OBŚŁUGA (patrz strona 39)

Hansgrohe zaleca, by z rana lub po dłuższym czasie niekorzystania, pierwsze pół litra wody nie używać jako wody pitnej.



ZNAK JAKOŚCI (patrz strona 44)

USTERKA	PRZYCZYNA	POMOC
/ Mała ilość wody	/ Napowietrzacz zakamieniony, zabrudzony	/ Oczyszczyć / wymienić napowietrzacz
/ Uchwyt armatury pracuje z wysiłkiem	/ Uszkodzony wkład, zakamieniony	/ Wymiana wkładu
/ Armatura cieknie	/ Uszkodzony wkład	/ Wymiana wkładu
/ Wyciek wody przy mocowaniu od dołu	/ Zbyt słabo wkręcone wężyki w korpus / Uszkodzony o-ring przy wężu przyłączeniowym	/ Dokręcić wężyki / Wymienić o-ring
/ Za niska temperatura ciepłej wody	/ Niewłaściwe ustawienie ogranicznik ciepłej wody	/ Ustawić ogranicznik ciepłej wody

△ BEZPEČNOSTNÍ POKYNY

- △ Pro zabránění řezným zraněním a pohmožděninám je nutné při montáži nosit rukavice.
- △ Je nutné vyrovnat velké rozdíly tlaku mezi přípoji studené a teplé vody.

POKYNY K MONTÁŽI

- / Před montáží je třeba produkt zkontrolovat, zda nebyl při transportu poškozen. Po zabudování nebudou uznány žádné škody způsobené transportem nebo poškození povrchu.
- / Vedení a armatura musí být namontovány, propláchnuty a otestovány podle platných norem.
- / Je třeba dodržovat montážní pravidla platné v dané zemi.

TECHNICKÉ ÚDAJE

Provozní tlak:	max. 1 MPa
Doporučený provozní tlak:	0,1 - 0,5 MPa
Zkušební tlak:	1,6 MPa
	(1 MPa = 10 bar = 147 PSI)
Teplota horké vody:	max. 60°C
Teplná desinfekce:	70°C / 4 min

- / Vlastní ijištění proti zpětnému nasátí.
- / Výrobky Hansgrohe jsou vhodné pro přímý kontakt s pitnou vodou.

POPIS SYMBOLŮ



Nepoužívat silikon s obsahem kyseliny octové!

NASTAVENÍ (viz strana 38)

Nastavení omezovače teplé vody. Ve spojení s průtokovým ohříváčem se použití uzávěru teplé vody nedoporučuje.



ÚDRŽBA (viz strana 41)

U zpětných ventilů se musí podle EN 806-5 v souladu s národními nebo regionálními předpisy testovat jejich funkčnost (alespoň jednou ročně).



ROZMĚRY (viz strana 42)



DIAGRAM PRŮTOKU (viz strana 42)

SERVISNÍ DÍLY (viz strana 43)

XXX = Kód povrchové úpravy

000 = Chrom

020 = Polished Chrome

130 = Polished Bronze

140 = Brushed Bronze

250 = Brushed Gold-Optic

260 = Brushed Chrome

300 = Polished Redgold

310 = Brushed Redgold

330 = Polished Black Chrome

340 = Brushed Black Chrome

800 = Stainless Steel Optic

820 = Brushed Nickel

830 = Polished Nickel

930 = Polished Brass

950 = Brushed Brass

990 = Polished Gold-Optic



ČIŠTĚNÍ (viz strana 40)



OVLÁDÁNÍ (viz strana 39)

Hansgrohe doporučuje ráno nebo po delších přestávkách nepoužívat prvního půl litru jako pitnou vodu.



ZKUŠEBNÍ ZNAČKA (viz strana 44)

PORUCHA	PŘÍČINA	ODSTRANĚNÍ
/ Málo vody	/ perláro zanesen vodním kamenem, znečištěn	/ vyčistit/vyměnit perlátor
/ Armatura jde ztěžka	/ Kartuše je vadná, zanesená-vodním kamenem	/ Kartuši vyměnit
/ Armatura odkapává	/ Kartuše je vadná	/ Kartuši vyměnit
/ výstup vody na upevňovacím násadci	/ přípojovací hadice nejsou dostatečně zašroubovány do tělesa	/ přípojovací hadice utáhnout rukou
	/ O-kroužek na přípojovací hadici je defektní	/ vyměnit O-kroužek
/ Nízká teplota teplé vody	/ Špatně nastavená zarážka pro teplotu	/ Seřídít zarážku pro teplotu vodu

MONTÁŽ (viz strana 34)



△ BEZPEČNOSTNÉ POKYNY

- △ Pri montáži musíte nosiť rukavice, aby ste predišli pomliaždeninám a rezným poraneniam.
- △ Veľké rozdiely v tlaku medzi prípojkami studenej a teplej vody musia byť vyrovnané.

POKYNY PRE MONTÁŽ

- / Pred montážou musíte produkt skontrolovať, či nebol počas transportu poškodený. Po zabudovaní nebudú uznané žiadne škody spôsobené transportom alebo poškodenia povrchu.
- / Potrubia a vybavenie musia byť namontované, prepláchnuté a vybavené v platnom normami.
- / Je potrebné dodržiavať smernice o inštalácii, ktoré sú práve teraz platné v krajinách.

TECHNICKÉ ÚDAJE

Prevádzkový tlak:	max. 1 MPa
Doporučený prevádzkový tlak:	0,1 - 0,5 MPa
Skúšobný tlak:	1,6 MPa
	(1 MPa = 10 bar = 147 PSI)
Teplota teplej vody:	max. 60°C
Termická dezinfekcia:	70°C / 4 min

- / Vlastná poisťka proti spätnému nasatiu.
- / Výrobok je koncipovaný výhradne pre pitnú vodu!

POPIS SYMBOLOV



Nepoužívať silikón s obsahom kyseliny octovej!



NASTAVENIE (viď strana 38)

Nastavenie obmedzenia teplej vody. V spojení s prietokovými ohrievačmi sa neodporúča použitie obmedzovača teplej vody.



ÚDRŽBA (viď strana 41)

Pri spätných ventiloch sa musí podľa EN 806-5 v súlade s národnými alebo regionálnymi

predpismi testovať ich funkčnosť (aspoň raz ročne).



ROZMERY (viď strana 42)

DIAGRAM PRIETOKU (viď strana 42)



SERVISNÉ DIELY (viď strana 43)

XXX = Farebné označenie
000 = Chróm
020 = Polished Chrome
130 = Polished Bronze
140 = Brushed Bronze
250 = Brushed Gold-Optic
260 = Brushed Chrome
300 = Polished Redgold
310 = Brushed Redgold
330 = Polished Black Chrome
340 = Brushed Black Chrome
800 = Stainless Steel Optic
820 = Brushed Nickel
830 = Polished Nickel
930 = Polished Brass
950 = Brushed Brass
990 = Polished Gold-Optic



ČISTENIE (viď strana 40)



OBSLUHA (viď strana 39)

Hansgrohe odporúča ráno a po dlhších dobách odstavky nepoužiť prvého pol litra vody ako pitnú vodu.



OSVEDČENIE O SKÚŠKE (viď strana 44)

PORUCHA	PRÍČINA	POMOC
/ Málo vody	/ Perlátor zanesený vodným kameňom	/ Vyčistiť alebo vymeniť perlátor
/ Armatúra "chodí" ťažko	/ Kartúša je poškodená, vápenaté usadeniny	/ Vymeniť kartúšu
/ Z armatúry kvapká voda	/ Kartúša je poškodená	/ Vymeniť kartúšu
/ Uhajanie vode ob pritrídilnem nastavku	/ Hadice pripojenia nie sú celkom zaskrutkované do základného telesa	/ Hadice pripojenia dotiahnuť ručne
	/ Chybný O krúžok na pripojovacej hadici	/ Vymeniť O krúžok
/ Nízka teplota teplej vody	/ Nesprávne nastavená zádržka na teplú vodu	/ Nastavenie zádržky na teplú vodu

MONTÁŽ (viď strana 34)



△ 安全技巧

- △ 装配时为避免挤压和切割受伤，必须戴上手套。
- △ 冷热水管间过大的压力差必须予以平衡。

安装提示

- / 安装前必须检查产品是否受到运输损害。安装后将不认可运输损害或表面损伤。
- / 管道和阀门必须根据通用标准进行安装、冲洗和检查。
- / 请遵守当地国家现行的安装规定。

技术参数

工作压力:	最大 1 MPa
推荐工作压力:	0,1 - 0,5 MPa
测试压强:	1,6 MPa (1 MPa = 10 bar = 147 PSI)
热水温度:	最大 60°C
热力消毒:	70°C / 4 分钟

- / 自动防止回流
- / 该产品专为饮用水设计！

符号说明



请勿使用含有乙酸的硅胶！



调节 (参见第页 38)

热水温度调节。如果使用即热式喷头，则不建议安装热水阀门。



保养 (参见第页 41)

单向阀必须在符合国家或当地的法律的情况下按照EN 806-5定期检查 (至少一年一次)。

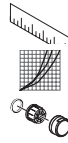

大小 (参见第页 42)

流量示意图 (参见第页 42)

备用零件 (参见第页 43)

XXX = 颜色代码

000 = 镀铬

020 = Polished Chrome

130 = Polished Bronze

140 = Brushed Bronze

250 = Brushed Gold-Optic

260 = Brushed Chrome

300 = Polished Redgold

310 = Brushed Redgold

330 = Polished Black Chrome

340 = Brushed Black Chrome

800 = Stainless Steel Optic

820 = Brushed Nickel

830 = Polished Nickel

930 = Polished Brass

950 = Brushed Brass

990 = Polished Gold-Optic



清洗 (参见第页 40)



操作 (参见第页 39)

汉斯格雅建议，清晨或在水流长时间停滞时，前半升水不作饮用水使用。



检验标记 (参见第页 44)

问题	原因	补救
/ 龙头出水量小	/ 起泡器结垢，脏污	/ 检查起泡器，视需要更换
/ 龙头不灵活	/ 阀芯损坏，结垢	/ 更换阀芯
/ 龙头滴水	/ 阀芯损坏	/ 更换阀芯
/ 水从螺纹底座中流出	/ 连接软管没有完全旋入基体	/ 用手拧紧连接软管
	/ 连接软管的O形环损坏	/ 更换O形环
/ 热水温度过低	/ 温度限制器设置错误	/ 设置温度限制器

△ УКАЗАНИЯ ПО ТЕХНИКЕ БЕЗОПАСНОСТИ

- △ Во время монтажа следует надеть перчатки во избежание прищемления и порезов.
- △ донного клапа. Перед установкой смесителя необходимо регулировочными кранами выровнять давление холодной и горячей воды при помощи вентилей регулирующих подачу воды в квартиру.

УКАЗАНИЯ ПО МОНТАЖУ

- / Перед монтажом следует проверить изделие на предмет повреждений при перевозке. После монтажа претензии о возмещении ущерба за повреждения при перевозке или повреждения поверхностей не принимаются.
- / Трубы и арматура должны быть установлены, промыты и проверены в соответствии с действующими нормами.
- / Необходимо соблюдать требования по монтажу, действующие в соответствующих странах.

ТЕХНИЧЕСКИЕ ДАННЫЕ

Рабочее давление: не более 1 МПа

Рекомендуемое рабочее давление: 0,1 - 0,5 МПа

Давлении: 1,6 МПа
(1 МПа = 10 bar = 147 PSI)

Температура горячей воды: не более 60°C

Термическая дезинфекция: 70°C/4 мин

- / укомплектован клапаном обратного тока воды
- / Изделие предназначено исключительно для питьевой воды!

ОПИСАНИЕ СИМВОЛОВ



Не применяйте силикон, содержащий уксусную кислоту.



ПОДГОНКА (см. стр. 38)

Регулировка ограничителя горячей воды. В сочетании с проточными нагревателями не рекомендуется использовать блокировку воды.



ТЕХНИЧЕСКОЕ ОБСЛУЖИВАНИЕ (см. стр. 41)

Защита обратного тока должна регулярно проверяться (минимум один раз в год) по стандарту EN 806-5 или в соответствии с национальными или региональными нормативами



РАЗМЕРЫ (см. стр. 42)



СХЕМА ПОТОКА (см. стр. 42)



КОМПЛЕКТ (см. стр. 43)

XXX = Цветная кодировка

000 = Хром

020 = Polished Chrome

130 = Polished Bronze

140 = Brushed Bronze

250 = Brushed Gold-Optic

260 = Brushed Chrome

300 = Polished Redgold

310 = Brushed Redgold

330 = Polished Black Chrome

340 = Brushed Black Chrome

800 = Stainless Steel Optic

820 = Brushed Nickel

830 = Polished Nickel

930 = Polished Brass

950 = Brushed Brass

990 = Polished Gold-Optic



ОЧИСТКА (см. стр. 40)



ЭКСПЛУАТАЦИЯ (см. стр. 39)

Hansgrohe рекомендует по утрам либо после длительного перерыва в использовании не использовать первые поллитра воды для питья.



ЗНАК ТЕХНИЧЕСКОГО КОНТРОЛЯ (см. стр. 44)

НЕИСПРАВНОСТЬ

ПРИЧИНА

УСТРАНЕНИЕ НЕИСПРАВНОСТИ

/ недостаточный давление (если устан напор воды)	/ Аэратор засорен накипью, загрязнен	/ Очистите/замените аэратор
/ Арматура работает с усилием	/ Картридж неисправен, засорение накипью	/ Замените картридж
/ Арматура протекает	/ Картридж неисправен	/ Замените картридж
/ Выход воды у основания крепления	/ Шланги подключения не полностью завернуты в корпус	/ Затяните шланги подключения вручную
	/ Уплотнительное кольцо круглого сечения на соединительном шланге неисправно	/ Замените уплотнительное кольцо круглого сечения
/ Температура горячей воды слишком низкая	/ Ограничение горячей воды отрегулировано неправильно	/ Отрегулируйте ограничение горячей воды

МОНТАЖ (см. стр. 34)



△ TURVALLISUUSOHJEET

- △ Asennuksessa on käytettävä käsineitä puristumien ja viiltojen aiheuttamien tapaturmien estämiseksi.
- △ Suuret paine-erot kylmä- ja kuumavesiliitäntöjen välillä on tasattava.

ASENNUSOHJEET

- / Ennen asennusta on tarkastettava tuotteen mahdolliset kuljetusvahingot. Asennuksen jälkeen kuljetus- ja pintavaurioita ei hyväksytä.
- / Putket ja hana on asennettava, huuhdeltava ja tarkastettava voimassa olevien standardien mukaisesti.
- / Jokaisessa maassa on noudatettava siellä päteviä asennusohjeita.

TEKNISET TIEDOT

Käyttöpaine:	maks. 1 MPa
Suosittelun käyttöpaine:	0,1 - 0,5 MPa
Koestuspaine:	1,6 MPa
	(1 MPa = 10 bar = 147 PSI)
Kuuman veden lämpötila:	maks. 60°C
Lämpödesinfektio:	70°C / 4 min

- / Estää itsestään paluuvirtauksen
- / Tuote on suunniteltu käytettäväksi ainoastaan juomaveden kanssa!

MERKIN KUVAUS



Älä käytä etikkahappopitoista silikonia!



SÄÄTÖ (katso sivu 38)

Lämpötilan rajoittimen säätäminen. Emme suosittele käyttämään lämpötilan rajoitinta vedenlämmittimen (läpivirtauskuumennin) yhteydessä.



HUOLTO (katso sivu 41)

Vastaventtiilin toiminta on tarkastettava säännöllisesti paikallisten ja kansallisten määräysten mukaisesti (EN 806-5, vähintään kerran vuodessa).



MITAT (katso sivu 42)



VIRTAUSDIAGRAMMI (katso sivu 42)



VARAOSAT (katso sivu 43)

XXX =	Värikoodaus
000 =	Kromi
020 =	Polished Chrome
130 =	Polished Bronze
140 =	Brushed Bronze
250 =	Brushed Gold-Optic
260 =	Brushed Chrome
300 =	Polished Redgold
310 =	Brushed Redgold
330 =	Polished Black Chrome
340 =	Brushed Black Chrome
800 =	Stainless Steel Optic
820 =	Brushed Nickel
830 =	Polished Nickel
930 =	Polished Brass
950 =	Brushed Brass
990 =	Polished Gold-Optic



PUHDISTUS (katso sivu 40)



KÄYTTÖ (katso sivu 39)

Hansgrohe suosittelee, että ensimmäistä puolta litraa ei käytetä juomavetenä aamuisin eikä silloin, kun laitetta ei ole käytetty pitkään aikaan.



KOESTUSMERKKI (katso sivu 44)

HÄIRIÖ

SYY

TOIMENPIDE

/ Vähän vettä	/ Poresuutin kalkkeutunut, likaantunut	/ Puhdista/vaihda poresuutin
/ Hana on raskaskäyttöinen	/ Patruuna rikki, kalkkikerrostumia	/ Vaihda patruuna
/ Hanasta tippuu vettä	/ Patruuna rikki	/ Vaihda patruuna
/ Vettä valuu kiinnityskauluksesta	/ Liitosletkut eivät ole kierretty kiinni perusrunkoon pohjaan asti	/ Kierrä liitosletkut kiinni käsikireyteen
	/ Liitosletkun O-renkas on rikki	/ Vaihda O-renkas
/ Lämminveden lämpötila liian alhainen	/ Lämminveden rajoitin väärin säädetty	/ Säädä lämminveden rajoitin



△ SÄKERHETSANVISNINGAR

- △ Handskar ska bäras under monteringsarbetet så att man kan undvika kläm- och skärskador.
- △ Stora tryckskillnader mellan anslutningarna för varmt och kallt vatten måste utjämnas.

MONTERINGSANVISNINGAR

- / Det måste undersökas om produkten har transportskador innan den monteras. Efter monteringen accepteras inga transport- eller ytskiktsskador.
- / Ledningarna och blandaren måste monteras, spolats igenom och kontrolleras enligt de gällande normerna.
- / De installationsriktlinjer som gäller i länderna ska följas.

TEKNISKA DATA

Driftstryck:	max. 1 MPa
Rek. driftstryck:	0,1 - 0,5 MPa
Tryck vid provtryckning:	1,6 MPa (1 MPa = 10 bar = 147 PSI)
Varmvattentemperatur:	max. 60°C
Termisk desinfektion:	70°C / 4 min

- / Självspärr mot återflöde
- / Produkten är enbart avsedd för dricksvatten!

SYMBOLFÖRKLARING

Använd inte silikon som innehåller ättiksyra!



JUSTERING (se sidan 38)

Ställa in varmvattenregleringen. Tillsammans med varmvattenberedare rekommenderas inte en varmvattenspärr.



SKÖTSEL (se sidan 41)

Backventilens funktion måste kontrolleras regelbundet enligt nationella eller regionala bestämmelser i enlighet med EN 806-5 (minst en gång per år).

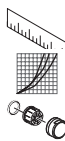

MÄTTEN (se sidan 42)

FLÖDESSCHEMA (se sidan 42)

RESERVDELAR (se sidan 43)

XXX = Färgkodning
000 = Krom
020 = Polished Chrome
130 = Polished Bronze
140 = Brushed Bronze
250 = Brushed Gold-Optic
260 = Brushed Chrome
300 = Polished Redgold
310 = Brushed Redgold
330 = Polished Black Chrome
340 = Brushed Black Chrome
800 = Stainless Steel Optic
820 = Brushed Nickel
830 = Polished Nickel
930 = Polished Brass
950 = Brushed Brass
990 = Polished Gold-Optic



RENGÖRING (se sidan 40)



HANTERING (se sidan 39)

Hansgrohe rekommenderar att den första halvlitern inte används som dricksvatten på morgonen eller efter längre perioder utan användning.



TESTSIGILL (se sidan 44)

STÖRNING**ORSAK****ÅTGÄRD**

/ För lite vatten	/ Areator är täckt av kalk, smutsig	/ Rengör/byt areator
/ Blandare är trög	/ Patron defekt, förkalkad	/ Byt ut patron
/ Blandare droppar	/ Patron defekt	/ Byt ut patron
/ Vatten kommer ut vid monteringsstaget	/ Anslutningsslangar inte helt inskruvade i grundkonstruktionen	/ Drag fast anslutningsslangar för hand.
	/ O-ring på anslutningsslang defekt	/ Byt ut O-ring
/ Varmvattentemperaturen är för låg	/ Varmvattenreglering felaktigt inställd	/ Ställ in varmvattenreglering

MONTERING (se sidan 34)



△ SAUGUMO TECHNIKOS NURODYMAI

- △ Apsaugai nuo užspaudimo ir įsijovimo montavimo metu mūvėkite pirštines.
- △ Turi būti išlyginti šalto ir karšto slėgio nelygumai.

MONTAVIMO INSTRUKCIJA

- / Prieš montuojant būtina patikrinti, ar gaminys nebuvo pažeistas transportavimo metu. Sumontavus pretenzijos dėl transportavimo ir paviršiaus pažeidimų nepriimamos.
- / Vamzdžiai ir sujungimai turi būti montuojami, plaunami ir tikrinami pagal galiojančias normas.
- / Laikykitės atitinkamoje šalyje galiojančių direktyvų dėl įrengimo.

TECHNINIAI DUOMENYS

Darbinis slėgis: ne daugiau kaip 1 MPa
 Rekomenduojamas slėgis: 0,1 - 0,5 MPa
 Bandomasis slėgis: 1,6 MPa
 (1 MPa = 10 barų = 147 PSI)
 Karšto vandens temperatūra: ne daugiau kaip 60°C
 Terminis dezinfekavimas: 70°C / 4 min

- / Su atbuliniu vožtuvu
- / Produktas skirtas tik geriamajam vandeniui!

SIMBOLIO APRAŠYMAS



Nenaudokite silikono, kurio sudėtyje yra acto rūgšties!



REGULIAVIMAS (žr. psl. 38)

Karšto vandens ribojimas. Kartu su cirkuliaciniais šildytuvais nerekomenduojama naudoti karšto vandens blokavimo įtaisų.



TECHNINIS APTARNAVIMAS
(žr. psl. 41)

Atbulinio vožtuvo apsauga privalo būti tikrinama reguliariai (mažiausiai kartą per metus) pagal EN 806-5 arba pagal galiojančias nacionalines arba regionines normas.



IŠMATAVIMAI (žr. psl. 42)



PRALAUDUMO DIAGRAMA
(žr. psl. 42)



ATSARGINĖS DALYS (žr. psl. 43)

XXX = Spalvos
 000 = Chrom
 020 = Polished Chrome
 130 = Polished Bronze
 140 = Brushed Bronze
 250 = Brushed Gold-Optic
 260 = Brushed Chrome
 300 = Polished Redgold
 310 = Brushed Redgold
 330 = Polished Black Chrome
 340 = Brushed Black Chrome
 800 = Stainless Steel Optic
 820 = Brushed Nickel
 830 = Polished Nickel
 930 = Polished Brass
 950 = Brushed Brass
 990 = Polished Gold-Optic



VALYMAS (žr. psl. 40)



EKSPLOATACIJA (žr. psl. 39)

Naudojant po ilgesnės pertraukos, „Hansgrohe“ rekomenduoja pirmo pusės litro vandens nevartoti kaip geriamojo.



BANDYMO PAŽYMA (žr. psl. 44)

GEDIMAS	PRIEŽASTIS	PRIEMONĖ
/ Per maža srovė	/ Perlatorius apkalkėjęs, užsikimšęs	/ Perlatorių išvalyti/pakeisti
/ Sunkiai sukiojama rankenėlė	/ Kasetė pažeista, užkalkėjusi	/ Pakeisti kasetę
/ Maišytuvus praleidžia vandenį	/ Kasetė pažeista	/ Pakeisti kasetę
/ Prateka vanduo per tvirtinimo kotą	/ Prijungimo žarnos nepilnai įsuktos į kar-	/ Prijungimo žarnos prisukti ranka pusę
	/ Pajungimo žarnos tarpinė pažeista	/ tarpinę pakeisti
/ Per maža karšto vandens temperatūra	/ Neteisingai nustatytas karšto vandens ribotuvas	/ Nustatyti karšto vandens ribotuvą

MONTAVIMAS (žr. psl. 34)



△ SIGURNOSNE UPUTE

- △ Prilikom montaže se radi sprječavanja prignječenja i posjekotina moraju nositi rukavice.
- △ Velika razlika u pritisku između vruće i hladne vode mora biti izbalansirana.

UPUTE ZA MONTAŽU

- / Prije montaže mora se provjeriti je li proizvod oštećen prilikom transporta. Nakon ugradnje se ne priznaju nikakve reklamacije koje se odnose na površinska i transportna oštećenja.
- / Cijevi i armatura moraju biti postavljeni, isprani i testirani prema važećim normama.
- / Obvezno se moraju uvažiti propisi o instalacijama koji vrijede u dotičnoj zemlji.

TEHNIČKI PODATCI

Najveći dopušteni tlak:	tlak 1 MPa
Preporučeni tlak:	0,1 - 0,5 MPa
Probni tlak:	1,6 MPa
	(1 MPa = 10 bar = 147 PSI)
Temperatura vruće vode:	tlak 60°C
Termička dezinfekcija:	70°C / 4 min

- / Funkcije samo-čišćenja
- / Proizvod je koncipiran isključivo za pitku vodu!

OPIS SIMBOLA

Nemojte koristiti silikon koji sadrži octenu kiselinu!



REGULACIJA (pogledaj stranicu 38)

Namještanje limitera tople vode. U kombinaciji s protočnim bojlerima nije preporučljiva primjena sustava za blokiranje dotoka tople vode.



ODRŽAVANJE (pogledaj stranicu 41)

Ispravnost nepovratnog ventila mora se redovito provjeravati prema standardu EN 806-5 i u skladu sa važećim propisima (najmanje jednom godišnjel).



MJERE (pogledaj stranicu 42)



DIJAGRAM PROTOKA
(pogledaj stranicu 42)



REZERVNI DJELOVI
(pogledaj stranicu 43)

XXX = Boje
000 = Krom
020 = Polished Chrome
130 = Polished Bronze
140 = Brushed Bronze
250 = Brushed Gold-Optic
260 = Brushed Chrome
300 = Polished Redgold
310 = Brushed Redgold
330 = Polished Black Chrome
340 = Brushed Black Chrome
800 = Stainless Steel Optic
820 = Brushed Nickel
830 = Polished Nickel
930 = Polished Brass
950 = Brushed Brass
990 = Polished Gold-Optic



ČIŠĆENJE (pogledaj stranicu 40)



UPOTREBA (pogledaj stranicu 39)

Hansgrohe preporuča da ujutro ili nakon duljeg nekorištenja prvih 1/2 litre vode ne upotrebljavate za piće.



OZNAKA TESTIRANJA
(pogledaj stranicu 44)

GREŠKA	UZROK	OTKLANJANJE
/ Nedovoljno vode	/ Aerator je začepljen naslagama kalcijevog kamenca ili prljav	/ Očistite ili zamijenite aerator.
/ Ručica se zaglavila	/ Neispravan uložak Taloženje kamenca	/ Zamijenite uložak
/ Slavina kaplje	/ Neispravan uložak	/ Zamijenite uložak
/ Voda izlazi na dijelu gdje je slavina učvršćena	/ Priključna crijeva nisu potpuno učvršćena na tijelo	/ Priključna crijeva učvrstite rukom
	/ O-prsteni priključnih crijeva su neispravni	/ Zamijenite O-prsten
/ Preniska temperatura tople vode	/ Limiter vruće vode nije dobro podešen	/ Podesite limiter vruće vode

SASTAVLJANJE (pogledaj stranicu 34)



△ INSTRUCȚIUNI DE SIGURANȚĂ

- △ La montare utilizați mănuși pentru evitarea contuziunilor și tăierii mâinilor.
- △ Diferențele de presiune mari între alimentarea cu apă rece și apă caldă trebuie echilibrate.

INSTRUCȚIUNI DE MONTARE

- / Înainte de instalare verificați, dacă produsul prezintă deteriorări de transport. După instalare garanția nu acoperă deteriorările de transport și cele de suprafață.
- / Conductele și bateriile trebuie montate, spălate și verificate conform normelor în vigoare.
- / Respectați reglementările referitoare la instalare valabile în țara respectivă.

DATE TEHNICE

Presiune de funcționare: max. 1 MPa
 Presiune de funcționare recomandată: 0,1 - 0,5 MPa
 Presiune de verificare: 1,6 MPa
 (1 MPa = 10 bar = 147 PSI)

Temperatura apei calde: max. 60°C
 Dezinfecție termică: 70°C/4 min

- / Asigurat contra scurgere înapoi
- / Produsul este destinat exclusiv pentru apă potabilă.

DESCRIEREA SIMBOLURILOR

 Nu utilizați silicon cu conținut de acid acetic!

 **REGLARE** (vezi pag. 38)

Reglarea limitatorului de apă caldă. Nu se recomandă folosirea unui limitator de apă caldă în combinație cu un boiler instant.

 **ÎNTREȚINERE** (vezi pag. 41)

Supapele antiretur trebuie verificate regulat conform EN 806-5 și standardele naționale sau regionale (cel puțin o dată pe an).

 **DIMENSIUNI** (vezi pag. 42)

 **DIAGRAMA DE DEBIT**
(vezi pag. 42)

 **PIESE DE SCHIMB** (vezi pag. 43)

XXX = Coduri de culori
 000 = Crom
 020 = Polished Chrome
 130 = Polished Bronze
 140 = Brushed Bronze
 250 = Brushed Gold-Optic
 260 = Brushed Chrome
 300 = Polished Redgold
 310 = Brushed Redgold
 330 = Polished Black Chrome
 340 = Brushed Black Chrome
 800 = Stainless Steel Optic
 820 = Brushed Nickel
 830 = Polished Nickel
 930 = Polished Brass
 950 = Brushed Brass
 990 = Polished Gold-Optic

 **CURĂȚARE** (vezi pag. 40)

 **UTILIZARE** (vezi pag. 39)

Hansgrohe vă recomandă, ca dimineața sau după perioade mai lungi de pauză să nu folosiți prima jumătate de litru de apă pentru băut.

 **CERTIFICAT DE TESTARE**
(vezi pag. 44)

DERANJAMENT	CAUZA	MĂSURI DE REMEDIERE
/ Prea puțină apă	/ Depunerile de calcar și impurități pe pulverizatorul de aer.	/ Curățați/schimbați pulverizatorul de aer.
/ Bateria se mișcă dificil	/ Cartuș defect din cauza depunerilor de calcar	/ Schimbați cartușul.
/ Bateria picură	/ Cartuș defect	/ Schimbați cartușul.
/ Scurgere de apă la șaftul de fixare.	/ Furtunurile de racordare nu sunt bine înșurubate în corpul bateriei.	/ Strângeți cu mâna furtunurile de racordare.
	/ Inelul O de la furtunul de racord defect	/ Schimbați inelul O.
/ Temperatura apei calde este prea mică	/ Limitarea temperaturii apei calde setată incorect.	/ Setați limitarea temperaturii apei calde.

MONTARE (vezi pag. 34) 

ΔΥΠΟΔΕΙΞΕΙΣ ΑΣΦΑΛΕΙΑΣ

- Δ Για να αποφύγετε τραυματισμούς κατά τη συναρμολόγηση πρέπει να φοράτε γάντια.
- Δ Οι διαφορές της πίεσης μεταξύ της σύνδεσης κρύου και ζεστού νερού θα πρέπει να αντισταθμίζονται.

ΟΔΗΓΙΕΣ ΣΥΝΑΡΜΟΛΟΓΗΣΗΣ

- / Πριν τη συναρμολόγηση πρέπει να εξεταστεί το προϊόν για ζημιές μεταφοράς. Μετά την εγκατάσταση δεν αναγνωρίζονται ζημιές από τη μεταφορά ή επιφανειακές ζημιές.
- / Οι σΩλήνες και η μπαταρία πρέπει να τοποθετηθούν σύμφωνα με τα ισχύοντα πρότυπα, να τεθούν υπό πίεση και να δοκιμαστούν.
- / Θα πρέπει να τηρούνται οι οδηγίες εγκατάστασης που ισχύουν σε κάθε κράτος.

ΤΕΧΝΙΚΑ ΧΑΡΑΚΤΗΡΙΣΤΙΚΑ

Λειτουργία πίεσης: ξΩς 1 MPa
 Συνιστώμενη λειτουργία πίεσης: 0,1 - 0,5 MPa
 Πίεση ελέγχου: 1,6 MPa
(1 MPa = 10 bar = 147 PSI)
 Θερμοκρασία ζεστού νερού: ξΩς 60°C
 Θερμική απολύμανση: 70°C / 4 min

- / Περιλαμβάνει βαλβίδα αντεπιστροφής.
- / Το προϊόν έχει σχεδιαστεί αποκλειστικά για πόσιμο νερό!

ΠΕΡΙΓΡΑΦΗ ΣΥΜΒΟΛΩΝ

 Μην χρησιμοποιείτε σιλικόνη που περιέχει οξικό οξύ!

 **ΡΥΘΜΙΣΗ** (βλ. Σελίδα 38)

Ρύθμιση του δοσομετρητή ζεστού νερού. Δεν συνιστάται η διάταξη φραγής ζεστού νερού σε συνδυασμό με ταχυθερμοσίφωνα.

 **ΣΥΝΤΗΡΗΣΗ** (βλ. Σελίδα 41)

Οι βαλβίδες αντεπιστροφής πρέπει να ελέγχονται τακτικά Ως προς τη λειτουργία τους, σύμφωνα με το πρότυπο EN 806-5, σε σχέση με τους ισχύοντες εθνικούς ή τοπικούς κανόνες (το ελάχιστο μια φορά το χρόνο) .

 **ΔΙΑΣΤΑΣΕΙΣ** (βλ. Σελίδα 42)

 **ΔΙΑΓΡΑΜΜΑ ΡΟΗΣ** (βλ. Σελίδα 42)

 **ΑΝΤΑΛΛΑΚΤΙΚΑ** (βλ. Σελίδα 43)

- XXX = Χρώματα
- 000 = ΕπιχρΩμωμένο
- 020 = Polished Chrome
- 130 = Polished Bronze
- 140 = Brushed Bronze
- 250 = Brushed Gold-Optic
- 260 = Brushed Chrome
- 300 = Polished Redgold
- 310 = Brushed Redgold
- 330 = Polished Black Chrome
- 340 = Brushed Black Chrome
- 800 = Stainless Steel Optic
- 820 = Brushed Nickel
- 830 = Polished Nickel
- 930 = Polished Brass
- 950 = Brushed Brass
- 990 = Polished Gold-Optic

 **ΚΑΘΑΡΙΣΜΟΣ** (βλ. Σελίδα 40)

 **ΧΕΙΡΙΣΜΟΣ** (βλ. Σελίδα 39)

Η Hansgrohe συνιστά το πρώι ή μετά από μεγάλα χρονικά διαστήματα αχρησίας να μην χρησιμοποιείτε το πρώτο μισό λίτρο νερό σαν πόσιμο.

 **ΣΗΜΑ ΕΛΕΓΧΟΥ** (βλ. Σελίδα 44)

ΒΛΑΒΗ	ΑΙΤΙΑ	ΔΙ'ΟΡΘΩΣΗ
/ Ανεπαρκές νερό	/ Άλατα και βρωμιά στο φίλτρο	/ Καθαρίστε/αλλάξτε το φίλτρο
/ Σκληρή μπαταρία (μείκτης)	/ Ελαττωματικό φυσίγγιο, άλατα	/ Αλλαγή φυσιγγίου
/ Η μπαταρία στάζει	/ Ελαττωματικό φυσίγγιο	/ Αλλαγή φυσιγγίου
/ Διαρροή νερού στον άξονα στερέωσης	/ Οι σΩλήνες σύνδεσης δεν είναι πλήρως βιδωμένοι στο βασικό κορμό	/ Σφίξτε τους σΩλήνες σύνδεσης με το χέρι
	/ Ο στρογγυλός δακτύλιος στο σΩλήνα σύνδεσης είναι ελαττωματικός	/ Αλλάξτε το στρογγυλό δακτύλιο
/ Χαμηλή θερμοκρασία ζεστού νερού	/ Λάθος ρύθμιση της περιοριστικής διάταξης ζεστού νερού	/ Ρυθμίστε την περιοριστική διάταξη του ζεστού νερού

△ VARNOSTNA OPOZORILA

- △ Pri montaži je treba nositi rokavice, da se preprečijo poškodbe zaradi zmečkanja ali urezov.
- △ Velike razlike v tlaku med priključkom za mrzlo in priključkom za toplo vodo je potrebno izravnati.

NAVODILA ZA MONTAŽO

- / Pred montažo je treba izdelek preveriti glede morebitnih transportnih poškodb. Po vgradnji transportne ali površinske poškodbe ne bodo več priznane.
- / Cevi in armaturo je treba montirati, izprati in preveriti po veljavnih standardih.
- / Upoštevati je treba pravilnike o inštalacijah, ki veljajo v posamezni državi.

TEHNIČNI PODATKI

Delovni tlak:	maks. 1 MPa
Priporočeni delovni tlak:	0,1 - 0,5 MPa
Preskusni tlak:	1,6 MPa
	(1 MPa = 10 bar = 147 PSI)
Temperatura tople vode:	maks. 60°C
Termična dezinfekcija:	70°C/4 min

- / Zaščita proti povratnemu toku
- / Proizvod je zasnovan izključno za sanitarno vodo!

OPIS SIMBOLA

Ne smete uporabiti silikona, ki vsebuje ocatno kislino!



J U S T I R A N J E (glejte stran 38)

Nastavitev omejevalnika tople vode. V povezavi s pretočnimi grelniki uporaba zapore tople vode ni priporočljiva.



V Z D R Ž E V A N J E (glejte stran 41)

Delovanje protipovratnega ventila je potrebno v skladu z EN 806-5 in skladno z državnimi in

regionalnimi določili redno testirati (najmanj enkrat letno).

M E R E (glejte stran 42)



DIAGRAM PRETOKA
(glejte stran 42)



REZERVNI DELI (glejte stran 43)

XXX	= Barve
000	= Krom
020	= Polished Chrome
130	= Polished Bronze
140	= Brushed Bronze
250	= Brushed Gold-Optic
260	= Brushed Chrome
300	= Polished Redgold
310	= Brushed Redgold
330	= Polished Black Chrome
340	= Brushed Black Chrome
800	= Stainless Steel Optic
820	= Brushed Nickel
830	= Polished Nickel
930	= Polished Brass
950	= Brushed Brass
990	= Polished Gold-Optic

Č I Š Č E N J E (glejte stran 40)



U P R A V L J A N J E (glejte stran 39)

Hansgrohe priporoča, da zjutraj ali po daljšem času stagnacije prvega pol litra vode ne uporabite kot pitno vodo.



P R E S K U S N I Z N A K (glejte stran 44)

N A P A K A**V Z R O K****P O M O Č**

/ Malo vode	/ Perlator poapnen; umazan	/ Očistite/zamenjajte perlator
/ Teško premikanje armature	/ Pokvarjen vložek, poapneno	/ Zamenjajte vložek
/ Iz armature kaplja	/ Pokvarjen vložek	/ Zamenjajte vložek
/ Uhajanje vode ob pritrdilnem nastavku	/ Priključne cevi niso popolnoma privijačene v osnovno ogrodje	/ Ročno zatisnite priključne cevi
	/ Obročna tesnila priključnih gibkih cevi so pokvarjena	/ Zamenjajte obročno tesnilo
/ Prenizka temperatura tople vode	/ Omejevalnik tople vode ni pravilno nastavljen	/ Nastavite omejevalnik tople vode

M O N T A Ž A (glejte stran 34)



△ OHUTUSJUHISED

△ Kandke paigaldamisel muljumis- ja löikevigastuste vältimiseks kindaid.

△ Kui külma ja kuumu vee ühenduste surve on väga erinev, tuleb need tasakaalustada.

PAIGALDAMISJUHISED

- / Enne paigaldamist tuleb toodet kontrollida transpordikahjustuste osas. Pärast paigaldamist ei tunnustata enam transpordi- või pinnakahjustuste kaebuseid.
- / Voolikut ja segisti paigaldamisel, loputamisel ja kontrollimisel tuleb lähtuda kehtivatest normatiividest.
- / Vastavas riigis kehtivaid paigalduseeskirju tuleb järgida.

TEHNILISED ANDMED

Töörõhk maks. 1 MPa
 Soovitatav töörõhk: 0,1 - 0,5 MPa
 Kontrollsurve: 1,6 MPa
 (1 MPa = 10 baari = 147 PSI)
 Kuuma vee temperatuur: maks. 60°C
 Termiline desinfitatsioon: 70°C/4 min

- / Tagasivooluklapp
- / Toode on ette nähtud eranditult joogivee jaoks!

SÜMBOLITE KIRJELDUS



Ärge kasutage äädikhapet sisaldavat silikooni!



REGULEERIMINE (vt lk 38)

Sooja vee piirangu seadistamine. Ühenduses boileritega ei ole sooja vee blokeeringu soovitatav.



HOOLDUS (vt lk 41)

Tagasilöögiplappide toimimist tuleb koostöös riiklike ja regionaalsete määrustega regulaarselt

kontrollida vastavalt standardile EN 806-5 (vähemalt kord aastas).

MÕÕTUDE (vt lk 42)

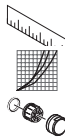

LÄBIVOOLUDIAGRAMM (vt lk 42)

VARUOSAD (vt lk 43)

XXX = Värvid
 000 = Kroom
 020 = Polished Chrome
 130 = Polished Bronze
 140 = Brushed Bronze
 250 = Brushed Gold-Optic
 260 = Brushed Chrome
 300 = Polished Redgold
 310 = Brushed Redgold
 330 = Polished Black Chrome
 340 = Brushed Black Chrome
 800 = Stainless Steel Optic
 820 = Brushed Nickel
 830 = Polished Nickel
 930 = Polished Brass
 950 = Brushed Brass
 990 = Polished Gold-Optic



PUHASTAMINE (vt lk 40)

KASUTAMINE (vt lk 39)

Hansgrohe soovib mitte kasutada esimest poolt liitrit hommikuti või pärast pikemat seisakuaega joogiveena.



KONTROLLSERTIFIKAAT (vt lk 44)

RIKE	PÕHJUS	LAHENDUS
/ Vähe vett	/ Sõel on lupjunud, must	/ Puhastage segisti sõel vajadusel vahetage
/ Segisti käib raskelt	/ Tööelement on katkine, lubjastunud	/ Vahetage tööelement
/ Segisti tilgub	/ Tööelement on katkine	/ Vahetage tööelement
/ Veeleke kinnituse juures	/ Ühendusvoolikud ei ole korralikult põhi-korpuse külge kruvitud	/ Kruvige ühendusvoolikud käega kinni
	/ Ühendusvoolikute O-rõngastihendid katki	/ Vahetage O-rõngastihend
/ Sooja vee temperatuur liiga madal	/ Kuuma vee piirang valesti seatud	/ Seadke kuuma vee piirang

PAIGALDAMINE (vt lk 34)



△ DROŠĪBAS NORĀDES

- △ Montāžas laikā, lai izvairītos no saspiedumiem un iegrīzumiem, nepieciešams nēsāt cimdus.
- △ Jāizlīdzina spiediena atšķirības starp aukstā un karstā ūdens pievadiem.

NORĀDĪJUMI MONTĀŽAI

- / Pirms montāžas nepieciešams pārbaudīt, vai produktam transportēšanas laikā nav radušies bojājumi. Pēc iebūvēšanas bojājumi, kas radušies transportēšanas laikā, vai virsmas bojājumi netiek atzīti.
- / Caurulvadi un armatūra ir jāuzstāda, jāizskalo un jāpārbauda saskaņā ar spēkā esošajiem standartiem.
- / Jāievēro attiecīgās valsts spēkā esošās montāžas prasības.

TEHNISKIE DATI

Darba spiediens: maks. 1 MPa
Ieteicamais darba spiediens: 0,1 - 0,5 MPa
Pārbaudes spiediens: 1,6 MPa
(1 MPa = 10 bar = 147 PSI)

Karstā ūdens temperatūra: maks. 60°C
Termiskā dezinfekcija: 70°C / 4 min

- / Drošības vārsts
- / Izstrādājums ir paredzēts tikai dzeramajam ūdenim!

SIMBOLU NOZĪME



Neizmantot silikonu, kas satur etiķskābi!

IEREGULĒŠANA (skat. lpp. 38)

Karsta ūdens ierobežotāja regulēšana. Kopā ar caurteces sildītājiem nav ieteicams izmantot ūdens bloķētāju.



APKOPE (skat. lpp. 41)

Regulāri jāpārbauda pretvārsta funkcija saskaņā ar EN 806-5 saistībā ar nacionālajiem vai vietējiem noteikumiem (vismaz vienreiz gadā).



IZMĒRUS (skat. lpp. 42)



CAURPLŪDES DIAGRAMMA (skat. lpp. 42)



REZERVES DAĻAS (skat. lpp. 43)

XXX = Krāsu kodi

000 = Hroma

020 = Polished Chrome

130 = Polished Bronze

140 = Brushed Bronze

250 = Brushed Gold-Optic

260 = Brushed Chrome

300 = Polished Redgold

310 = Brushed Redgold

330 = Polished Black Chrome

340 = Brushed Black Chrome

800 = Stainless Steel Optic

820 = Brushed Nickel

830 = Polished Nickel

930 = Polished Brass

950 = Brushed Brass

990 = Polished Gold-Optic



TĪRĪŠANA (skat. lpp. 40)



LIETOŠANA (skat. lpp. 39)

Hansgrohe iesaka no rīta vai pēc ilgākiem pārtraukumiem nelietot pirmo puslitru ūdens dzeršanai.



PĀRBAUDES ZĪME (skat. lpp. 44)

TRAUCĒJUMS

IEMESLS

BOJĀJUMU NOVĒRŠANA

/ Maz ūdens	/ Aerators aizkaļķojies, aizsērējis	/ Tīrīt/nomainīt aeratoru
/ Jaucējkrāns smagi grozāms	/ Bojāta kartuša, aizkaļķojusies	/ Nomainīt kartušu
/ Jaucējkrāns pil	/ Bojāta kartuša	/ Nomainīt kartušu
/ Ūdens noplūde pie nostiprinājuma	/ Pieslēguma šļūtenes nav līdz galam ieskrūvētas pamatelementā	/ Pieslēguma šļūtenes ar roku pievilkt stingrāk
	/ Bojāti pieslēguma šļūtenju O-gredzeni	/ Nomainīt O-gredzenu
/ Pārāk zema ūdens temperatūra	/ Nepareizi noregulāta karstā ūdens bloķēšana	/ Noregulēt karstā ūdens ierobežošanu bloķēšanu

MONTĀŽA (skat. lpp. 34)



△ SIGURNOSNE NAPOMENE

- △ Prilikom montaže se radi sprečavanja prignječenja i posekotine moraju nositi rukavice.
- △ Velika razlika u pritisku između vruće i hladne vode mora biti izbalansirana.

INSTRUKCIJE ZA MONTAŽU

- / Pre montaže se mora proveriti da li je proizvod oštećen pri transportu. Nakon ugradnje se ne priznaju nikakve reklamacije koje se odnose na površinska i transportna oštećenja.
- / Vodovi i armatura moraju biti postavljeni, isprani i testirani prema važećim normama.
- / Treba se pridržavati propisa koji u određenim zemljama važe za instalacije.

TEHNIČKI PODACI

Radni pritisak:	maks. 1 MPa
Preporučeni radni pritisak:	0,1 - 0,5 MPa
Probni pritisak:	1,6 MPa
	(1 MPa = 10 bar = 147 PSI)
Temperatura vruće vode:	maks. 60°C
Termička dezinfekcija:	70°C / 4 min

- / Zaštita od povratnog toka
- / Proizvod je koncipiran isključivo za pijaću vodu!

OPIS SIMBOLA



Nemojte koristiti silikon koji sadrži sircetnu kiselinu!



PODEŠAVANJE (vidi stranu 38)

Podešavanje ograničavača tople vode. U kombinaciji sa protočnim bojlerima ne preporučuje se primena sistema za blokiranje dotoka tople vode.



ODRŽAVANJE (vidi stranu 41)

Ispravno funkcionisanje nepovratnog ventila se mora redovno proveravati prema standardu EN 806-5 i u skladu s važećim nacionalnim ili regionalnim propisima (najmanje jednom godišnje).



MERE (vidi stranu 42)

DIJAGRAM PROTOKA (vidi stranu 42)



REZERVNI DELOVI (vidi stranu 43)

XXX = Oznake boja
 000 = Hrom
 020 = Polished Chrome
 130 = Polished Bronze
 140 = Brushed Bronze
 250 = Brushed Gold-Optic
 260 = Brushed Chrome
 300 = Polished Redgold
 310 = Brushed Redgold
 330 = Polished Black Chrome
 340 = Brushed Black Chrome
 800 = Stainless Steel Optic
 820 = Brushed Nickel
 830 = Polished Nickel
 930 = Polished Brass
 950 = Brushed Brass
 990 = Polished Gold-Optic



ČIŠĆENJE (vidi stranu 40)



RUKOVANJE (vidi stranu 39)

Hansgrohe preporučuje da ujutru ili nakon dužeg nekorišćenja prvih pola litre vode ne koristite za piće.



ISPITNI ZNAK (vidi stranu 44)

SMETNJA	UZROK	POMOĆ
/ Nedovoljno vode	/ Aerator je začepljen naslagama kamenca ili prljav	/ Očistite ili zamenite aerator
/ Ručica se zaglavila	/ Neispravna kartuša, nataloženi kamenac	/ Zamenite kartušu
/ Slavina kaplje	/ Neispravna kartuša	/ Zamenite kartušu
/ Voda izlazi na delu gde je slavina učvršćena	/ Priključna creva nisu potpuno učvršćena na telo	/ Priključna creva učvrstite rukom
	/ O prstenovi priključnih creva su neispravni	/ Zamenite O prsten
/ Preniska temperatura tople vode	/ Ograničavač vruće vode nije dobro podešen	/ Podesite ograničavač vruće vode

MONTAŽA (vidi stranu 34) 

△ SIKKERHETSHENVISNINGER

- △ Bruk hansker under montasjen for å unngå klem- og kuttskader.
- △ Store trykkdifferanser mellom kaldt- og varmtvannstilkoblinger skal utlignes.

MONTAGEHENVISNINGER

- / Før montasjen skal produktet sjekkes for transportskader. Etter monteringen aksepteres ikke noen transport- eller overflateskader.
- / Ledningene og armaturen skal monteres, spyles og sjekkes iht. de gyldige normer.
- / Gjeldende retningslinjer for rørleggerarbeid i de enkelte land skal følges.

TEKNISKE DATA

Driftstrykk	maks. 1 MPa
Anbefalt driftstrykk:	0,1 - 0,5 MPa
Prøvetrykk	1,6 MPa
	(1 MPa = 10 bar = 147 PSI)
Varmtvannstemperatur	maks. 60°C
Termisk desinfisering:	70°C / 4 min

- / Egensikker mot tilbakeflyt
- / Produktet er utelukkende designet for drikkevann!

SYMBOLBESKRIVELSE

 Ikke bruk silikon som inneholder eddiksyre!



JUSTERING (se side 38)

Innstilling av varmtvannsbegrensning. I forbindelse med gjennomstrømningsvarmere er det ikke anbefalt å bruke en varmtvannsperre.



VEDLIKEHOLD (se side 41)

Funksjonen til returløpssperren skal iht. EN 806-5 og i samsvar med de nasjonale og lokale

forskrifter sjekkes regelmessig (minst en gang i året).

MÅL (se side 42)



GJENNOMSTRØMNINGSDIAGRAM (se side 42)



SERVICEDELER (se side 43)

XXX = Fargekode
 000 = Krom
 020 = Polished Chrome
 130 = Polished Bronze
 140 = Brushed Bronze
 250 = Brushed Gold-Optic
 260 = Brushed Chrome
 300 = Polished Redgold
 310 = Brushed Redgold
 330 = Polished Black Chrome
 340 = Brushed Black Chrome
 800 = Stainless Steel Optic
 820 = Brushed Nickel
 830 = Polished Nickel
 930 = Polished Brass
 950 = Brushed Brass
 990 = Polished Gold-Optic



RENGJØRING (se side 40)

BETJENING (se side 39)

Om morgen og etter lengre stagnasjonstider anbefaler Hansgrohe å ikke bruke den første halvliteren som drikkevann.



PRØVEMERKE (se side 44)

FEIL	ÅRSAK	FEILRETTELSE
/ Lite vann	/ Luftsprudler forkalket, skitten	/ Luftsprudler rengjøres/byttes
/ Armatur ikke lett bevegelig	/ Kartusj defekt, forkalkning	/ Kartusj byttes
/ Armatur drypper	/ Kartusj defekt	/ Kartusj byttes
/ Vannlekkasje på festeskift	/ Tilkoblingslanger ikke skrudd helt inn i baseelement	/ Tilkoblingslanger trekkes fast fra hånd
	/ O-ring på tilkoblingslanger defekt	/ O-ring byttes
/ For lav varmtvannstemperatur	/ Varmtvannsbegrensning er feil innstilt	/ Varmtvannsbegrensning innstilles

MONTASJE (se side 34)



⚠ УКАЗАНИЯ ЗА БЕЗОПАСНОСТ

- ⚠ При монтажа трябва да се носят ръкавици, за да се избегнат наранявания поради притискане или порязване.
- ⚠ Големите разлики в налягането между изводите за студената и топлата вода трябва да се изравняват.

УКАЗАНИЯ ЗА МОНТАЖ

- / Преди монтажа продуктът трябва да се провери за транспортни щети. След монтажа не се признават транспортни или повърхностни щети.
- / Тръбопроводите и арматурата трябва да се монтират, промият и проверят в съответствие с валидните норми.
- / Трябва да бъдат спазвани валидните в съответните страни предписания за инсталиране.

ТЕХНИЧЕСКИ ДАННИ

Работно налягане:	макс. 1 МПа
Препоръчително работно налягане:	0,1 - 0,5 МПа
Контролно налягане:	1,6 МПа
	(1 МПа = 10 bar = 147 PSI)
Температура на горещата вода:	макс. 60°C
Термична дезинфекция:	70°C/4 мин

- / Самозащитен против обратно изтичане
- / Продуктът е разработен само за питейна вода!

ОПИСАНИЕ НА СИМВОЛИТЕ



Не използвайте силикон, съдържащ оцетна киселина!



ЮСТИРАНЕ (вижте стр. 38)

Настройка на ограничителя за топлата вода.
Във връзка с проточни нагреватели не се препоръчва блокировка за топлата вода



ПОЧИСТВАНЕ (вижте стр. 40)



ОБСЛУЖВАНЕ (вижте стр. 39)

Hansgrohe препоръчва, сутрин и след по-продължително спиране първият половин литър да не се използва като питейна вода.



КОНТРОЛЕН ЗНАК (вижте стр. 44)



ПОДДРЪЖКА (вижте стр. 41)

Съгласно EN 806-5 функционирането на приспособленията за предотвратяване на обратния поток трябва редовно да се проверява в съответствие с националните или регионалните изисквания (поне веднъж годишно).



РАЗМЕРИ (вижте стр. 42)



ДИАГРАМА НА ПОТОКА (вижте стр. 42)



СЕРВИЗНИ ЧАСТИ (вижте стр. 43)

XXX = Цветово кодиране
000 = Хром
020 = Polished Chrome
130 = Polished Bronze
140 = Brushed Bronze
250 = Brushed Gold-Optic
260 = Brushed Chrome
300 = Polished Redgold
310 = Brushed Redgold
330 = Polished Black Chrome
340 = Brushed Black Chrome
800 = Stainless Steel Optic
820 = Brushed Nickel
830 = Polished Nickel
930 = Polished Brass
950 = Brushed Brass
990 = Polished Gold-Optic

НЕИЗПРАВНОСТ

ПРИЧИНА

ПОМОЩ

/ Малко вода	/ Аераторът е покрит с варовик, замърсен	/ Почистете/сменете аератора
/ Трудно подвижна арматура	/ Дефектна гилза, покрита с варовик	/ Сменете гилзата
/ Арматурата капе	/ Дефектна гилза	/ Сменете гилзата
/ Избиване на вода от закрепващата шийка	/ Съвързащите маркучи не са напълно завинтени в основното тяло	/ Затегнете на ръка съвързащите маркучи
	/ Дефектен О-образен пръстен на съвързащия маркуч	/ Смяна на О-образен пръстен
/ Твърде ниска температура на водата	/ Ограничението за топлата вода е грушно настроено	/ Настройте ограничението за топлата вода

МОНТАЖ (вижте стр. 34)



△ 安全上の注意

- △ 施工の際は手を挟んだり怪我をしないように、手袋をはめてください。
- △ 給水・湯の圧力差は0.1(MPa)以内としてください。

施工上の注意

- / 製品の施工前に輸送でのダメージがないか確認してください。施工後のキズ等のお申し出はお断りさせていただきます。
- / 配管と水栓は、関連法規に従って施工、洗浄、および試験を行ってください。
- / 施工行う地域に適用される関連法規をお守りください。

技術資料

使用圧力: 最大 1 MPa
 推奨使用水圧: 0,1 - 0,5 MPa
 耐圧試験圧力: 1,6 MPa
 (1 MPa = 10 bar = 147 PSI)

給湯温度: 最大 60°C
 お湯による高温消毒: 70°C/4分

- / 逆流防止処置がされています
- / この製品は飲料水での使用が前提となっています (日本においては水道法に適合する飲料水)!

アイコンの説明



酢酸系シリコンをご使用にならないでください!



調整 (次のページを参照 38)

お湯の流量制限の設定方法。瞬間湯沸かし器をご利用の際はお湯の流量制限はしないでください。



メンテナンス (次のページを参照 41)

逆止弁は、EN 806-5に従って定期的 (少なくとも年に1回) に確認をしてください (日本においては関連法規に従ってください)。



寸法 (次のページを参照 42)

流量曲線図 (次のページを参照 42)



スペアパーツ (次のページを参照 43)

XXX = 仕上げ色
 000 = Chrome
 020 = Polished Chrome
 130 = Polished Bronze
 140 = Brushed Bronze
 250 = Brushed Gold-Optic
 260 = Brushed Chrome
 300 = Polished Redgold
 310 = Brushed Redgold
 330 = Polished Black Chrome
 340 = Brushed Black Chrome
 800 = Stainless Steel Optic
 820 = Brushed Nickel
 830 = Polished Nickel
 930 = Polished Brass
 950 = Brushed Brass
 990 = Polished Gold-Optic



お手入れ方法 (次のページを参照 40)



使用方法 (次のページを参照 39)

ハンスグローエは、朝または長い間使用されなかった後に吐水する最初の0.5リットルは飲料水として使用しないことをお勧めします。



認証について (次のページを参照 44)

症状	原因	対応策
/ 流量が少ない	/ エアレーターにカルキが付着汚れている	/ エアレーターを清掃交換をしてください
/ 水栓の開閉が重い	/ カルキによるカートリッジ不具合	/ カートリッジを交換してください
/ 水栓の水漏れ	/ カートリッジの不良	/ カートリッジを交換してください
/ 固定ネジ部分から水が漏れる	/ 接続ホースが本体に完全にねじ込まれていない	/ 接続ホースを手で増し締めしてください
	/ 接続ホースのOリングの不具合	/ Oリングを交換してください
/ 吐水温度が低すぎる	/ 温度リミッターの設定が正しくない	/ 温度リミッターを設定してください

施工方法 (次のページを参照 34)



△ UDHËZIME SIGURIE

- △ Për të evituar lëndimet e pickimeve ose të prerjeve gjatë procesit të montimit duhet që të vishni doreza.
- △ Ndryshimet e mëdha të presionit mes lidhjeve të ujit të ftohtë dhe atij të ngrohtë duhen ekuilibruar.

UDHËZIME PËR MONTIMIN

- / Përpara montimit duhet që produkti të kontrollohet për dëmtime nga transporti. Pas instalimit nuk do të njihet asnjë dëmtim nga transporti ose dëmtim i sipërfaqes.
- / Tubacionet dhe rubinetet duhet që të montohen, të shpëlahen dhe të kontrollohen sipas standardeve në fuqi
- / Duhet të respektohen linjat udhëzuese të instalimit, të vlefshme për vendet respektive.

TË DHËNA TEKNIKE

Presioni gjatë punës	maks. 1 MPa
Presioni i rekomanduar:	0,1 - 0,5 MPa
Presioni për provë:	1,6 MPa
	(1 MPa = 10 bar = 147 PSI)
Temperatura e ujit të ngrohtë	maks. 60°C
Dezinfektim Termik:	70°C / 4 min

- / Siguresa kundër rrjedhjes në drejtim të kundërt
- / Produkti është projektuar ekskluzivisht për ujë të pijshëm!

PËRSHKRIMI I SIMBOLIT



Mos përdorni silikon që në përbërje ka acid acetik.



J U S T I M I (shih faqen 38)

Rregullimi i kufizimit me ujë të nxehtë. Nje kombinim me një bojler ujit nuk është i rekomanduar.



MIRËMBAJTJA (shih faqen 41)

Penguesit e rrjedhjes në drejtim të kundërt duhen kontrolluar rregullisht në bazë të normave EN 806-5 konform normave nacionale dhe regionale (së paku një herë në vit).



PËR M A S A T (shih faqen 42)



DIAGRAMI I QARKULLIMIT (shih faqen 42)



PJESËT E S E R V I S I T (shih faqen 43)

XXX = Kodimi me anë të ngjyrave
 000 = Krom
 020 = Polished Chrome
 130 = Polished Bronze
 140 = Brushed Bronze
 250 = Brushed Gold-Optic
 260 = Brushed Chrome
 300 = Polished Redgold
 310 = Brushed Redgold
 330 = Polished Black Chrome
 340 = Brushed Black Chrome
 800 = Stainless Steel Optic
 820 = Brushed Nickel
 830 = Polished Nickel
 930 = Polished Brass
 950 = Brushed Brass
 990 = Polished Gold-Optic



P A S T R I M I (shih faqen 40)



PËR D O R I M I (shih faqen 39)

Hansgrohe rekomandon që në mëngjes ose pas periudhave të gjata që gjysmë litri i parë mos të pihet



S H E N J A E K O N T R O L L I T (shih faqen 44)

DEMTIM	SHKAKU	NDIHME
/ Pak ujë	/ Shperndaresi i ajrit me kalk, me papasterti	/ Pastroni shperndaresin e ajrit/kembejeni
/ Armatura punon rende	/ Kartusha me defekt, me kalk	/ Kembeni kartushen
/ Armatura pikon	/ Kartusha me defekt	/ Kembeni kartushen
/ Dalje e ujit ne cilindrin fiksues	/ Tubat e lidhjes jo komplet te vidhosur ne karkasen baze	/ Shtrengojini manualisht tubat e lidhur
	/ Unaza O tek tubi lidhes me defekt	/ Kembeni unazen O
/ Temperaturë e ulët e ujit të ngrohtë	/ Kufiri i ujit të ngrohte eshte regjistruar gabim	/ Regjistroni kufirin e ujit të ngrohte

⚠ تنبيهات الأمان

⚠ يجب إرتداء قفازات الليد أثناء التركيب لتجنب حدوث أخطار الإنحشار أو الجروح

⚠ يجب أن يكون تيار الماء الساخن والماء البارد متعادلين في الضغط.

تعليمات التركيب

/ قبل القيام بعملية التركيب، يجب فحص المنتج للتأكد من خلوه من أية تلفيات ناتجة عن النقل بعد القيام بعملية التركيب، لن يتم الاعتراف بوجود أية تلفيات سطحية أو تلفيات ناتجة عن عملية النقل.

/ يجب تركيب وغسيل واختبار التوصيلات وخلطات المياه طبقاً للمعايير السارية.

/ يجب مراعاة القواعد الخاصة بالتركيب وأعمال السباكة وفقاً للوائح الخاصة بكل بلد.

المواصفات الفنية

ضغط التشغيل: الحد الأقصى 1 ميجاباسكال
ضغط التشغيل الموصى به: 0,5 - 0,1 ميجاباسكال

ضغط الاختبار: 1,6 ميجاباسكال

(1 ميجاباسكال = 10 بار = 147 PSI)
درجة حرارة الماء الساخن: الحد الأقصى 60°C

تعقيم حراري: 4/70°C الدقيقة

/ خاصية عدم التدفق العكسي

/ المنتج مخصص فقط لماء الشرب!

وصف الرمز

هام! لا تستخدم السليكون الذي يحتوي على أمحاض! 

الضبط (راجع صفحة 38) 

ضبط تحديد المياه الدافئة. لا ينصح باستخدام محدد المياه الدافئة مع سخان المياه الوتقي.

الصيانة (راجع صفحة 41)

يجب فحص صمام عدم الرجوع بصفة منتظمة حسب المواصفة 5-EN 806 وذلك طبقاً للوائح الوطنية أو الإقليمية (مرة واحد سنوياً على الأقل).

أبعاد (راجع صفحة 42)

رسم للصفراء (راجع صفحة 42)

قطع الغيار (راجع صفحة 43)

الألوان = XXX

كروم = 000

Polished Chrome = 020

Polished Bronze = 130

Brushed Bronze = 140

Brushed Gold-Optic = 250

Brushed Chrome = 260

Polished Redgold = 300

Brushed Redgold = 310

Polished Black Chrome = 330

Brushed Black Chrome = 340

Stainless Steel Optic = 800

Brushed Nickel = 820

Polished Nickel = 830

Polished Brass = 930

Brushed Brass = 950

Polished Gold-Optic = 990

التنظيف (راجع صفحة 40)

التشغيل (راجع صفحة 39)

تنصح شركة هانزجر وهي Hansgrohe بعدم استخدام أول نصف لتر من الماء لغرض الشرب وذلك في الصباح أو بعد توقف استخدام الماء لفترات طويلة نسبياً.

شهادة اختبار (راجع صفحة 44)

العلاج والإصلاح

السبب

العطل

/ الماء غير كافٍ / خلاط الهواء متراكم عليه الجير / قم بتنظيف / تغيير خلاط الهواء / الإلتساخات

/ الخلاط ثقيل الحركة / الخرطوشة تالفة، تراكم عليها الجير / قم بتغيير الخرطوشة

/ تساقط قطرات مياه من الخلاط / الخرطوشة تالفة / قم بتغيير الخرطوشة

/ خروج الماء من جزء التثبيت / خراطيم التوصيل ليست مربوطة في / اربط خراطيم التوصيل بيدك الجزء الرئيسي بشكل كامل

/ الحلقة الدائرية الخاصة بخراطيم التوصيل تالفة / الحلقة الدائرية الخاصة بخراطيم التوصيل تالفة / قم بتغيير الحلقة الدائرية

/ درجة حرارة الماء الساخن منخفضة / محدد الماء الساخن مضبوط بشكل خاطيء / قم بضبط محدد الماء الساخن للغاية

التركيب (راجع صفحة 34) 

▲ GÜVENLİK UYARILARI

- ▲ Montaj esnasında ezilme ve kesilme gibi yaralanmaları önlemek için eldiven kullanılmalıdır.
- ▲ Sıcak ve soğuk su bağlantıları arasında büyük basınç farklılıkları varsa, bu basınç farklılıklarının dengelenmesi gerekir.

MONTAJ AÇIKLAMALARI

- / Montaj işleminden önce ürün nakliye hasarları yönünden kontrol edilmelidir. Montaj işleminden sonra nakliye veya yüzey hasarları için sorumluluk üstlenilmemektedir.
- / Boruların ve armatürün montajı, yıkanması ve kontrolü geçerli normlara göre yapılmalıdır.
- / Ülkelerde geçerli kurulum yönetmeliklerine riayet edilmelidir.

TEKNİK BİLGİLER

İşletme basıncı:	azami 1 MPa
Tavsiye edilen işletme basıncı:	0,1 - 0,5 MPa
Kontrol basıncı:	1,6 MPa
	(1 MPa = 10 bar = 147 PSI)

- Sıcak su sıcaklığı: azami 60°C
Termik dezenfeksiyon: 70°C/4 dak
- / Geri emme önleyici
 - / Ürün sadece şebeke suyu için tasarlanmıştır!

SİMGE AÇIKLAMASI

Asetik asit içeren silikon kullanmayın!



AYARLAMA (bakınız sayfa 38)

Sıcak su sınırlamasının ayarlanması. Sıcak su kilidinin sürekli ısıtıcıyla kullanılması tavsiye edilmez.



BAKIM (bakınız sayfa 41)

EN 806-5 ve ulusal standartlar doğrultusunda Çek valfler düzenli olarak kontrol edilmelidir. (en az yılda bir kez)



ÖLÇÜLERİ (bakınız sayfa 42)



AKIŞ DİYAGRAMI (bakınız sayfa 42)



YEDEK PARÇALAR (bakınız sayfa 43)

- XXX = Renkler
000 = Krom
020 = Polished Chrome
130 = Polished Bronze
140 = Brushed Bronze
250 = Brushed Gold-Optic
260 = Brushed Chrome
300 = Polished Redgold
310 = Brushed Redgold
330 = Polished Black Chrome
340 = Brushed Black Chrome
800 = Stainless Steel Optic
820 = Brushed Nickel
830 = Polished Nickel
930 = Polished Brass
950 = Brushed Brass
990 = Polished Gold-Optic



TEMİZLEME (bakınız sayfa 40)



KULLANIMI (bakınız sayfa 39)

Hansgrohe sabahları uzun durgunluk süresi sonrasında ilk yarım litre suyun içme suyu olarak kullanılmamasını önerir.



KONTROL İŞARETİ
(bakınız sayfa 44)

ARIZA	SEBEP	YARDIM
/ Az su geliyor	/ Perlatör kireçlenmiş, kirlenmiş	/ Perlatör kireçlenmiş, kirlenmiş
/ Bataryaya kullanımı ağırlaşıyor	/ Kartuş Bozulmuş ve kireçlenmiş olabilir	/ Kartuşu değiştirin
/ Bataryaya su damlatıyor	/ Kartuş bozuk olabilir	/ Kartuşu değiştirin
/ Sabitleme kutusundan su çıkışı	/ Bağlantı hortumları ana gövdeye tamamen vidalanmamış	/ Bağlantı hortumlarını elinizle sıkın
	/ Bağlantı hortumundaki O-ring arızalı	/ O-ringi değiştirin
/ Sıcak suyun derecesi çok düşük	/ Isı limitleyici düzgün çalışmıyor	/ Isı limitleyiciyi yeniden ayarlayın

GARANTİ BELGESİ

ÜRETİCİ VEYA İTHALATÇI FIRMANIN

MALIN

Unvanı: Hansgrohe Armatür Ltd. Şti
Adresi: Fulya Mahallesi Bahçeler Sokak Efe han 20/C
Mecidiyeköy Şişli İstanbul
Telefonu: (0-212) 273 07 30
Faks: (0-212) 273 07 40
web adresi: www.hansgrohe.com.tr

Markası: Hansgrohe
Cinsi: Sıhhi tesisat malzemesi
Garanti Süresi: 2 YIL
Azami Tamir Süresi: 20 İş günü

GENEL MÜDÜR
ALBERT EMLEK



Satıcı Firmanın:

Fatura Tarih ve Sayısı:

Unvanı:

Marka ve Modeli:

Adresi:

Teslim Tarihi ve Yeri:

Telefonu:

Yetkilinin İmzası:

Faks:

Firmanın Kaşesi:

e-posta:

BU BÖLÜMÜ, ÜRÜNÜ ALDIĞINIZ YETKİLİ SATICI İMZALAYACAK VE KAŞELEYECEKTİR.



△ BIZTONSÁGI UTASÍTÁSOK

- △ A szerelésnél a zúzódások és vágási sérülések elkerülése érdekében kesztyűt kell viselni.
- △ A hidegvíz- és a melegvíz-csatlakozások közötti nagy nyomáskülönbséget kikell egyenlíteni!

SZERELÉSI UTASÍTÁSOK

- / A szerelés előtt ellenőrizni kell, hogy a terméknek nincs-e szállítási sérülése. Beépítés után a szállítási- vagy felületi sérüléseket nem ismerik el.
- / A vezetékeket és a csaptelepet az érvényes szabványoknak megfelelően kell felszerelni, öblíteni és ellenőrizni
- / Az egyes országokban érvényes installációs irányelveket be kell tartani.

MŰSZAKI ADATOK

Üzemi nyomás:	max. 1 MPa
Ajánlott üzemi nyomás:	0,1 - 0,5 MPa
Nyomáspróba:	1,6 MPa
	(1 MPa = 10 bar = 147 PSI)
Forróvíz hőmérséklet:	max. 60°C
Termikus fertőtlenítés:	70°C/4 perc

- / Visszafolyás gátlóval
- / A terméket kizárólag ivóvízhez tervezték!

SZIMBÓLUMOK LEÍRÁSA

Ne használjon ecetsavtartalmú szilikon!



BEÁLLÍTÁS (lásd a oldalon 38)

A meleg víz korlátozás beállítása. Átfolyós vízmelegítőknél meleg víz korlátozó használata nem ajánlott.



KARBANTARTÁS (lásd a oldalon 41)

A visszafolyásgátlók működése a EN 806-5 szabványnak megfelelően, a nemzeti vagy területi rendelkezésekkel összhangban, évente egyszer ellenőrizendő!



MÉRETET (lásd a oldalon 42)



ÁTFOLYÁSI DIAGRAMM
(lásd a oldalon 42)



TARTOZÉKOK (lásd a oldalon 43)

XXX	= Színkódolás
000	= Króm
020	= Polished Chrome
130	= Polished Bronze
140	= Brushed Bronze
250	= Brushed Gold-Optic
260	= Brushed Chrome
300	= Polished Redgold
310	= Brushed Redgold
330	= Polished Black Chrome
340	= Brushed Black Chrome
800	= Stainless Steel Optic
820	= Brushed Nickel
830	= Polished Nickel
930	= Polished Brass
950	= Brushed Brass
990	= Polished Gold-Optic



TISZTÍTÁS (lásd a oldalon 40)



HASZNÁLAT (lásd a oldalon 39)

- / A csaptelepeken átfolyt víz hőmérséklete fogyasztásra szánt víz esetében a 65°C-ot nem haladhatja meg. A csaptelep nem eredményezheti az emberi fogyasztásra (pl. ivás és főzés céljából) szánt víz minőségromlását.
- / Beüzemelés és üzemszünetek után szigorúan be kell tartani a használati útmutatóban leírtakat. Beüzemeléskor a csaptelepet át kell öblíteni, legalább 2 percig törtendő hideg- és melegvízes folytatást javasolunk. Minimum 1 napos üzemszünet után fogyasztás előtt a csaptelepben stagnáló hideg- illetve melegvíz fogyasztása nem javasolt, a csaptelepben stagnáló vizet ki kell engedni, legalább 2 perces folytatás javasolt. A kifolytatás során nyert vizet ivóvízként, illetve ételkészítési céllal felhasználni nem szabad.
- / Tekintettel arra, hogy a forró víz fémoldó képessége a hideg víznél nagyobb, emiatt főzés ivás céljából az OK! a hideg víz használatát javasolja.
- / A csaptelepek perlátorát javasolt havonta vízköteníteni, illetve fertőtleníteni. A csaptelepek tisztítása, fertőtlenítése során kizárólag olyan vegyszer alkalmazható, amely megfelel a 201/2001. (X.25) Kormányrendelet, illetve a 38/2003. (VII.7) ÉSzCsM-FVM-KvVM együttes rendeletben leírtaknak.

- / A perlátör működési elvéből adódóan jelentős aeroszolt képez, így Legionella expozíció szempontjából fokozott kockázatot jelent. Ezért alkalmazása nem javasolt az egészségügyi intézmények fekvőbeteg ellátó szobáiban, illetve minden olyan helyen, ahol a hideg és/vagy használati melegvíz Legionella csíraszámra eléri a 49/2015 (XI.6.) EMMI rendelet alapján meghatározott beavatkozási szintet.



V I Z S G A J E L (lásd a oldalon 44)

HIBA	OK	MEGOLDÁS
/ Kevés víz	/ A perlátör elvízkövesedett, elszennyeződött	/ A perlátört megtisztítani/kicserélni.
/ Nehezen nyitható a csap.	/ A kerámiabetét meghibásodott, elvízkövesedett.	/ A kerámiabetétet ki kell cserélni.
/ Csöpög a csap.	/ A kerámiabetét meghibásodott.	/ A kerámiabetétet ki kell cserélni.
/ Vízkilépés a rögzítőrúdon	/ A csatlakozótömlők nincsenek teljesen becsavarozva az akaptesztbe	/ A csatlakozótömlőket kézzel meghúzni
	/ Csatlakozótömlő tömítőgyűrűje meghibásodott	/ Tömítőgyűrű kicserélése
/ túl alacsony melegvíz hőmérséklet	/ A melegvíz szabályozó rosszul van beállítva.	/ A melegvíz szabályozót újra be kell állítani.



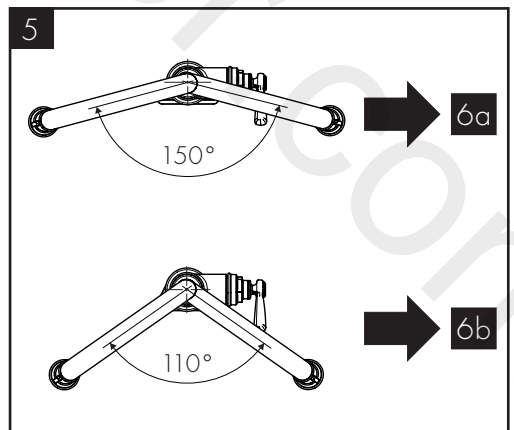
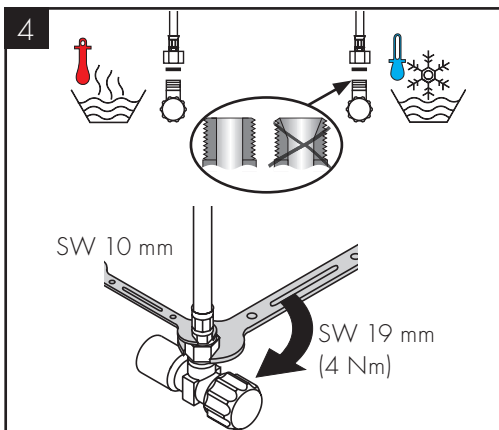
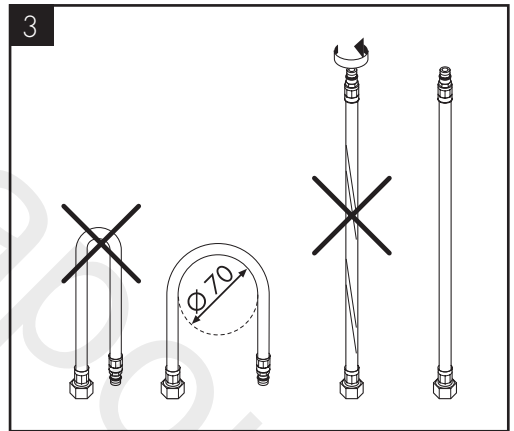
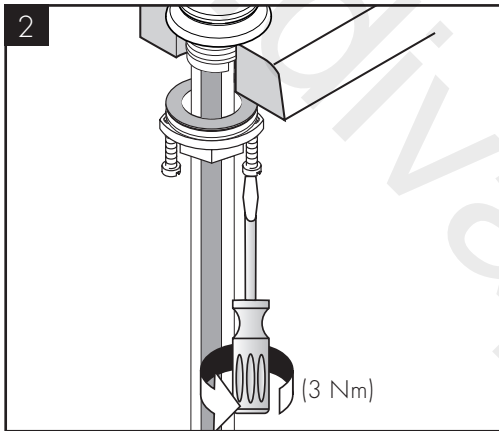
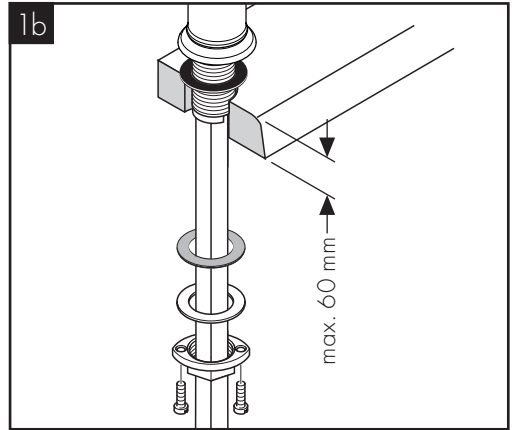
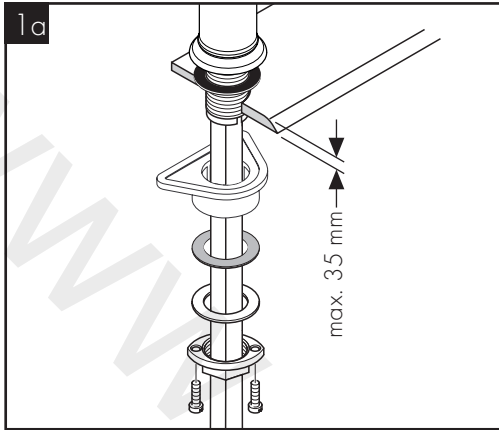



6a

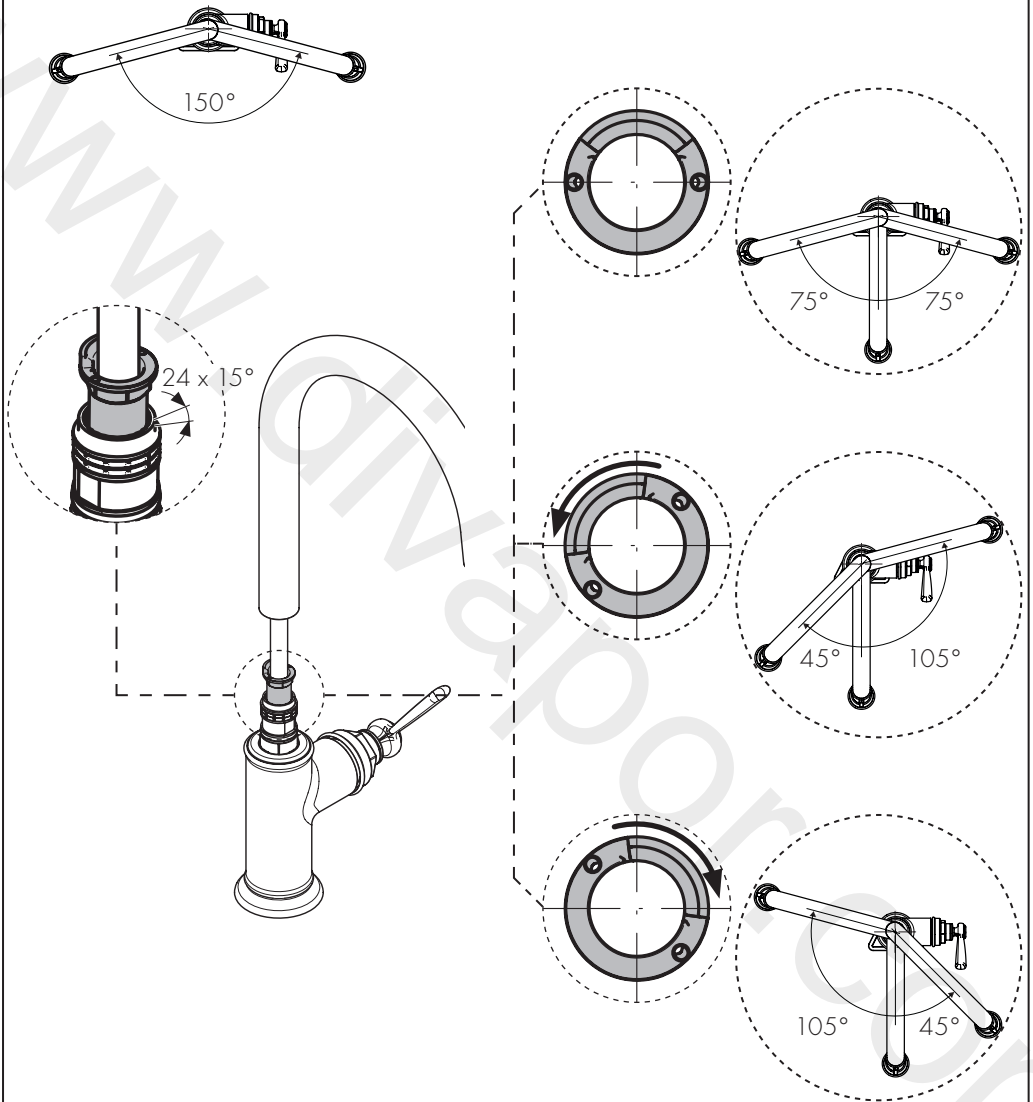



6b

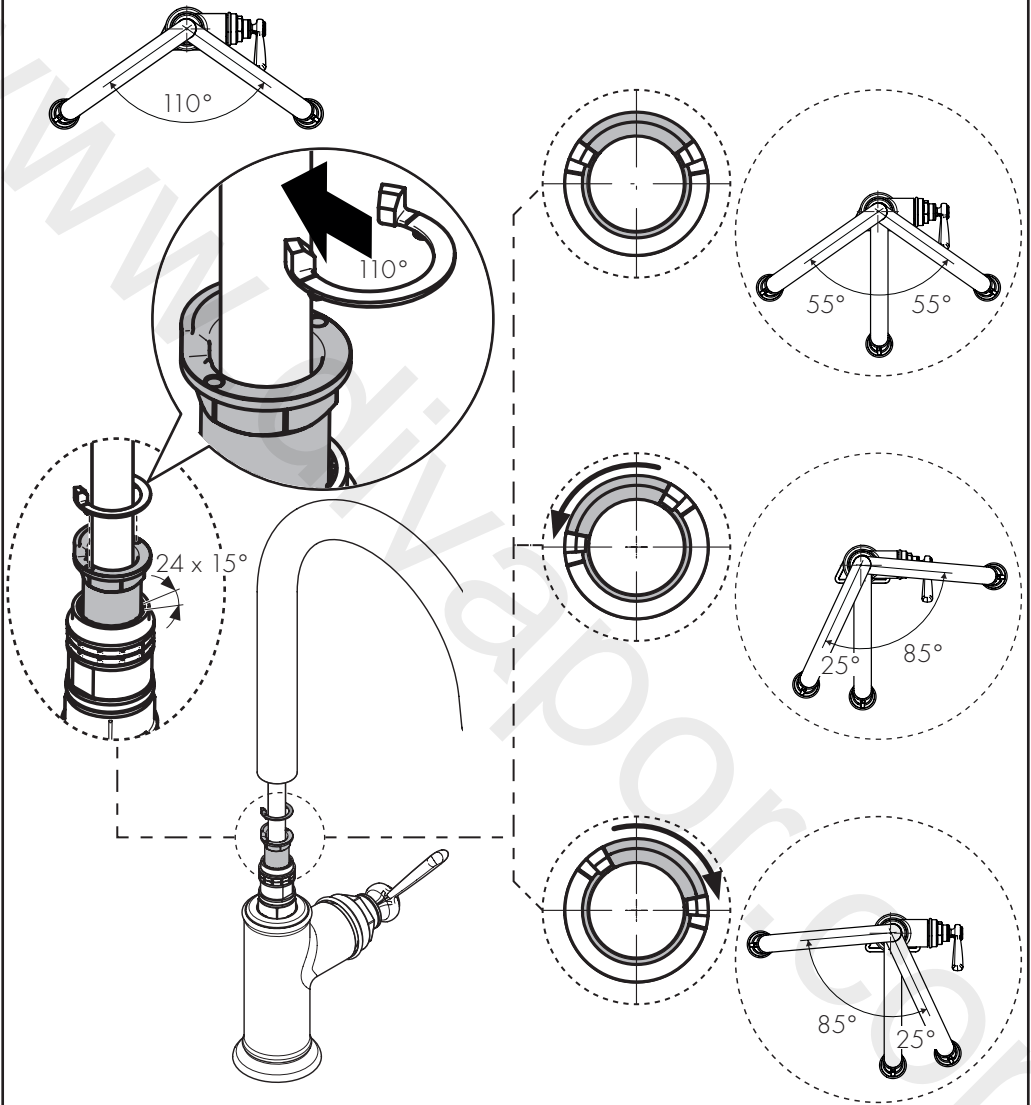

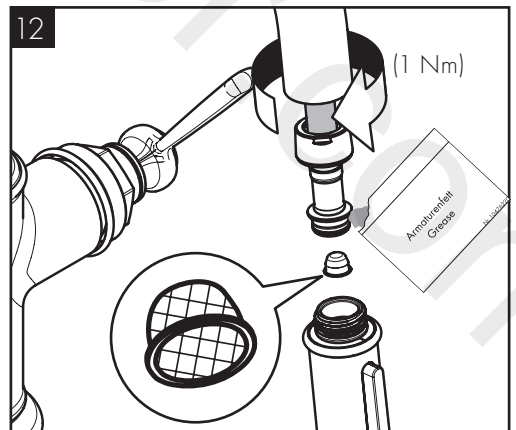
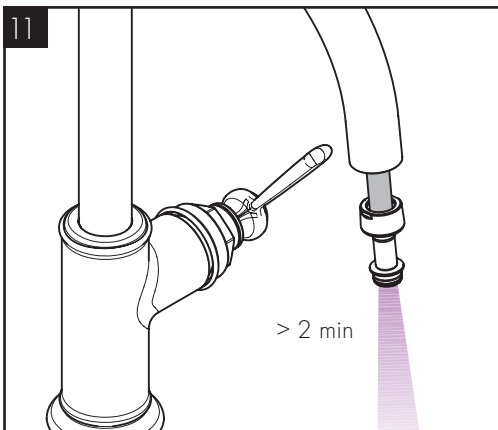
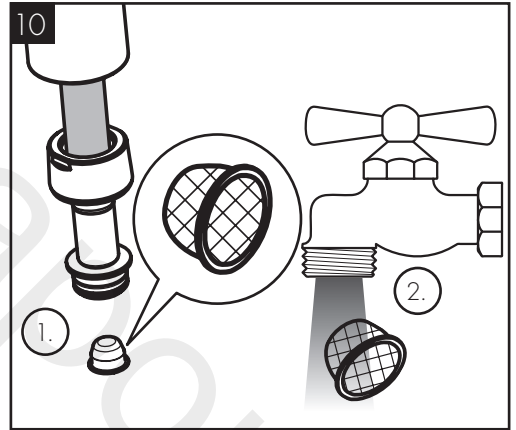
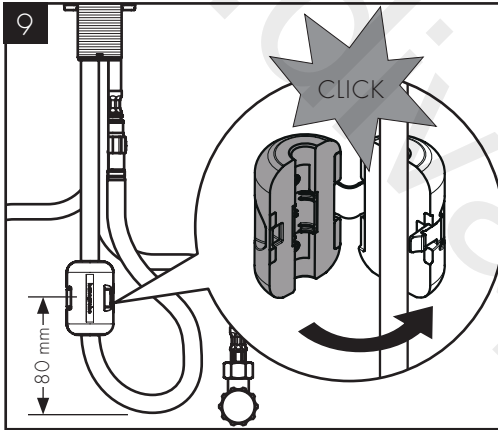
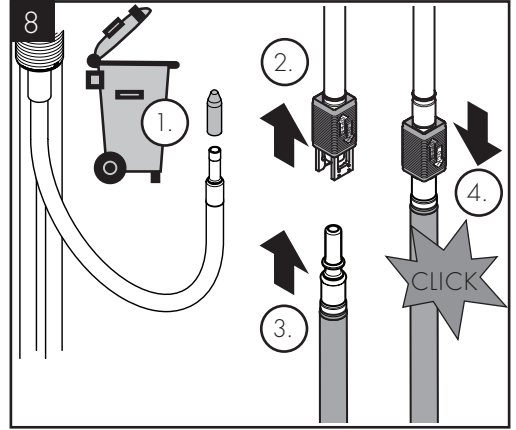
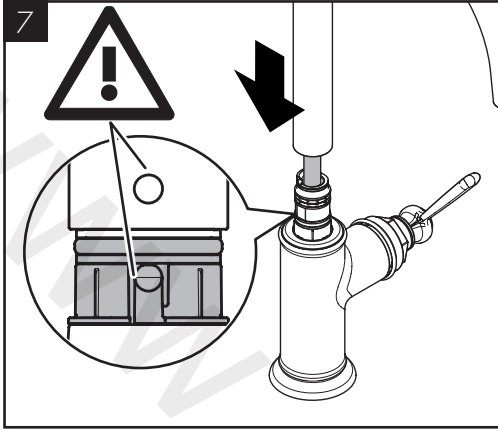

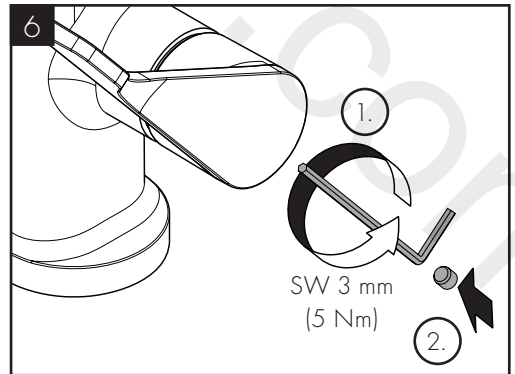
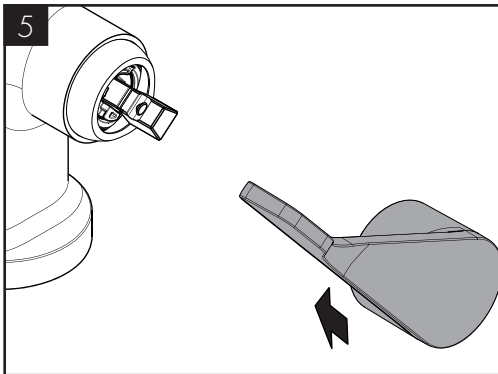
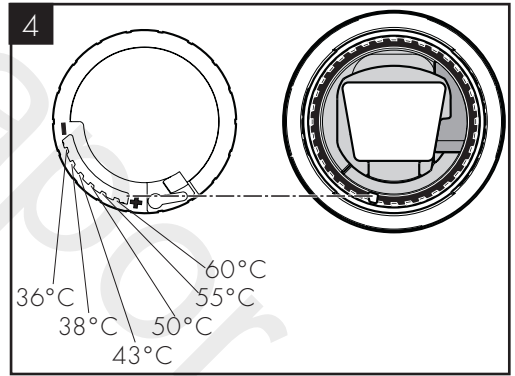
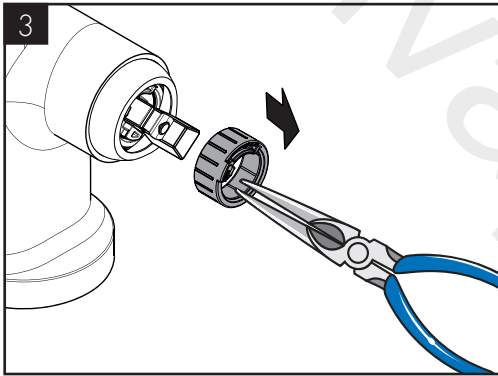
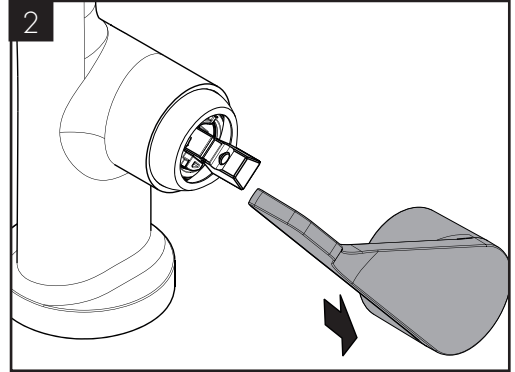
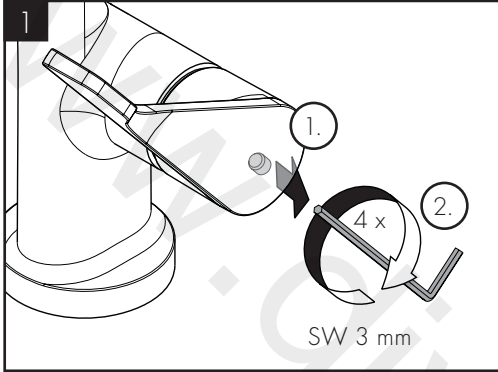





DE / Reinigungsempfehlung / Garantie / Kontakt
 FR / Recommandation pour le nettoyage / Garanties / Contact
 EN / Cleaning recommendation / Warranty / Contact
 IT / Raccomandazione di pulizia / Garanzia / Contatto
 ES / Recomendaciones para la limpieza / Garantía / Contacto
 NL / Aanbevelingen inzake reiniging / Garantie / Contact
 DK / Rengøringsvejledning / Garanti / Kontakt
 PT / Recomendações de limpeza / Garantia / Contacto
 PL / Zalecenie dotyczące pielęgnacji / Gwarancja / Kontakt
 CS / Doporučení k čištění / Záruka / Kontakt
 SK / Odporúčania pre čistenie / Záruka / Kontakt
 ZH / 清洁指南 / 担保 / 接触
 RU / Рекомендации по очистке / Гарантия / Контакты
 FI / Puhdistussuositus / Takuu / Kosketus
 SV / Rengöringsrekommendationer / Garanti / Contacto
 LT / Valymo rekomendacijos / Garantija / Kontaktai
 HR / Preporuke za čišćenje / Garancija / Kontakt
 TR / Temizleme önerisi / Garanti / Temas
 RO / Recomandări pentru curățare / Garanție / Contact
 EL / Σύσταση καθαρισμού / Εγγύηση / επαφή
 SL / Priporočilo za čiščenje / Garancija / Kontakt
 ET / Puhastussoovitused / Garantii / Kontakt
 LV / Tīrīšanas ieteikumi / Garantija / Kontakti
 SR / Preporuke za čišćenje / Garancija / Kontakt
 NO / Anbefaling for rengjøring / Garanti / Kontakt
 BG / Препоръка за почистване / Гаранция / Контакт
 SQ / Këshilla rreth pastrimit / Garancia / Kontakt
 KO / 세정시 권장사항 / 품질보증 / 접촉
 AR / توصيات التنظيف / الضمان / اتصال
 HU / Tisztítási tanácsok / Garancia / érintkezés
 JP / お手入れの方法 / 保証について / ご連絡先



[www.axor-design.com/
cleaning-recommendation](http://www.axor-design.com/cleaning-recommendation)

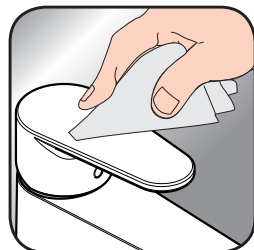

[www.axor-design.com/
cleaning-recommendation](http://www.axor-design.com/cleaning-recommendation)



[www.axor-design.com/
cleaning-recommendation](http://www.axor-design.com/cleaning-recommendation)



[www.axor-design.com/
cleaning-recommendation](http://www.axor-design.com/cleaning-recommendation)

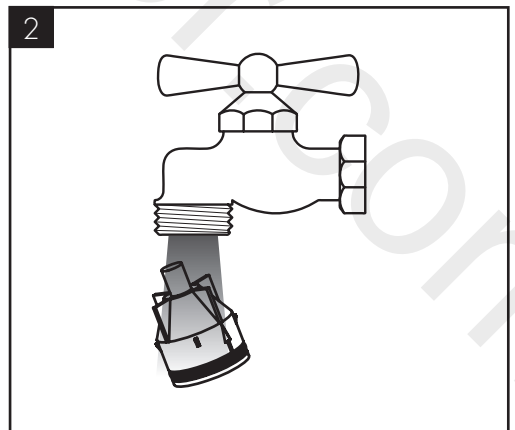
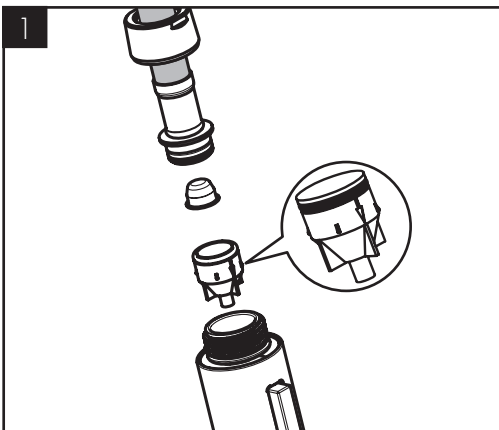
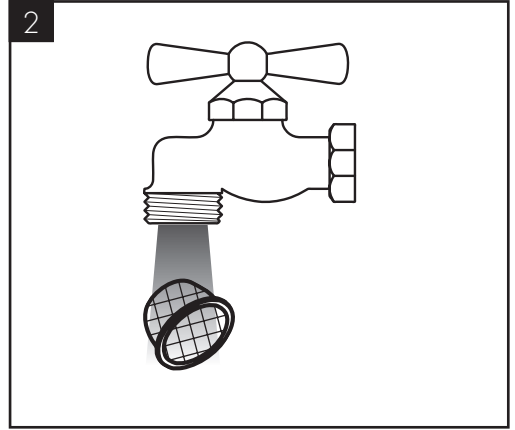
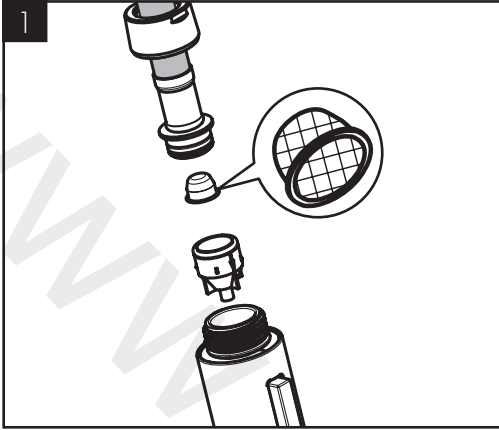



AXOR Montreux 180
16581XXX

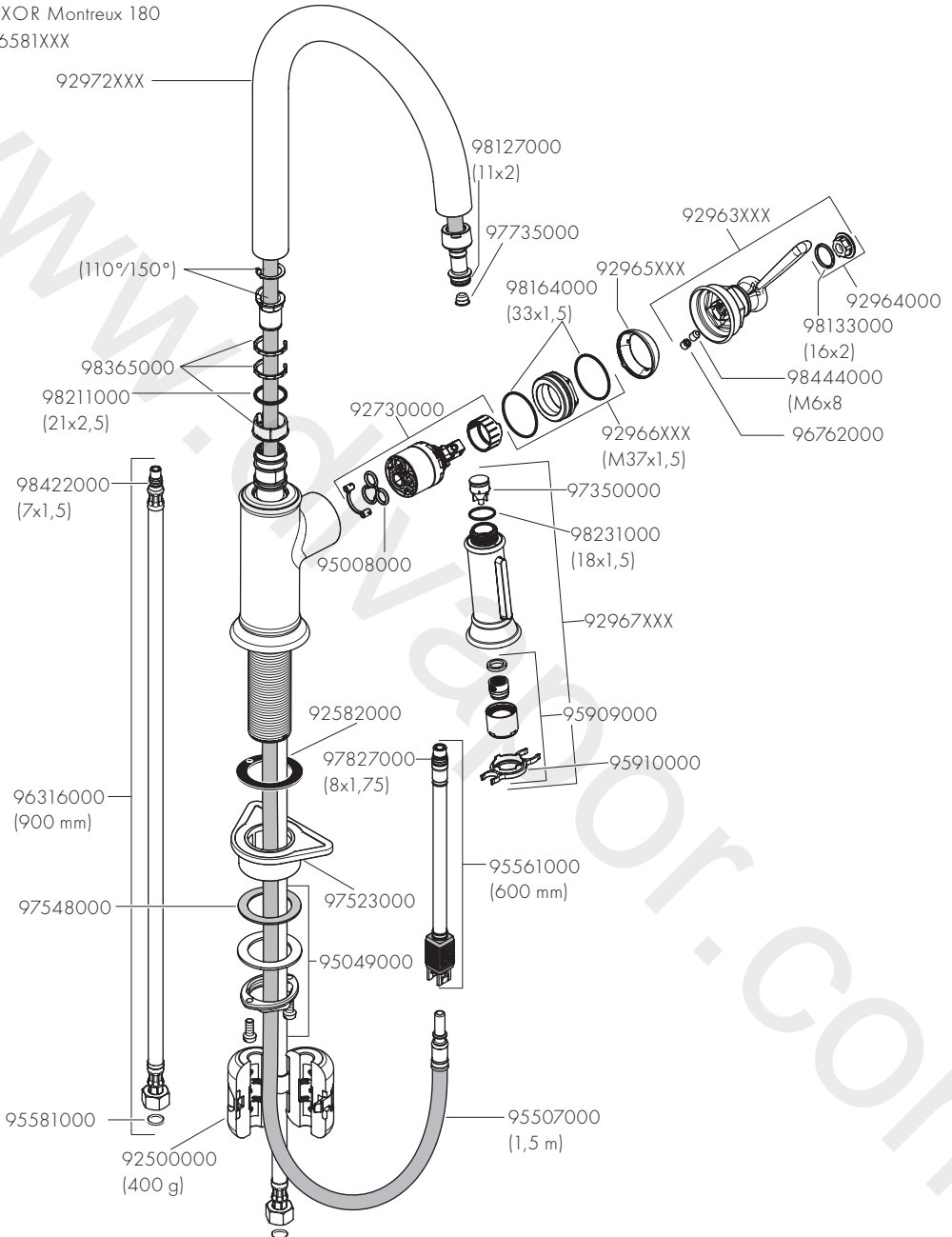

AXOR

P-IX

DVGW

SINTEF

NF



ETA

16581XXX

P-IX 7284/O

X

X

Hansgrohe SE

DIN 4109-1

P-IX 7284/O

Fraunhofer-Institut
für Bauphysik IBP

AXOR / Hansgrohe SE

Auestraße 5-9

77761 Schiltach

Deutschland

info@axor-design.com

axor-design.com

11/2021
9.05464.04