

| | | |
|-----------|---|---|
| DE | Gebrauchsanleitung / Montageanleitung | 2 |
| EN | Instructions for use / assembly instructions | 2 |
| FR | Mode d'emploi / Instructions de montage | 2 |
| IT | Istruzioni per l'uso / Istruzioni per Installazione | 2 |
| ES | Modo de empleo / Instrucciones de montaje | 3 |
| DK | Brugsanvisning / Monteringsvejledning | 3 |
| NL | Gebruiksaanwijzing / Handleiding | 3 |
| PT | Instruções para uso / Manual de Instalação | 3 |
| PL | Instrukcja obsługi / Instrukcja montażu | 4 |
| SK | Návod na použitie / Montážny návod | 4 |
| CS | Návod k použití / Montážní návod | 4 |
| ZH | 用户手册 / 组装说明 | 4 |
| RU | Руководство пользователя / Инструкция по монтажу | 5 |
| SV | Bruksanvisning / Monteringsanvisning | 5 |
| FI | Käyttöohje / Asennusohje | 5 |
| LT | Vartotojo instrukcija / Montavimo instrukcijos | 5 |
| HR | Upute za uporabu / Uputstva za instalaciju | 6 |
| RO | Manual de utilizare / Instrucțiuni de montare | 6 |
| TR | Kullanım kılavuzu / Montaj kılavuzu | 6 |
| EL | Οδηγίες χρήσης / Οδηγία συναρμολόγησης | 6 |
| SI | Navodilo za uporabo / Navodila za montažo | 7 |
| LV | Lietošanas pamācība / Montāžas instrukcija | 7 |
| ET | Kasutusjuhend / Paigaldusjuhend | 7 |
| SR | Uputstvo za upotrebu / Uputstvo za montažu | 7 |
| NO | Bruksanvisning / Montasjeveiledning | 8 |
| SQ | Udhëzuesi i përdorimit / Udhëzime rreth montimit | 8 |
| BG | Инструкция за употреба / Ръководство за монтаж | 8 |
| AR | دليل الاستخدام / تعليمات التجميع | 8 |
| HU | Használati útmutató / Szerelési útmutató | 9 |
| JP | 取扱説明書 / 施工説明書 | 9 |

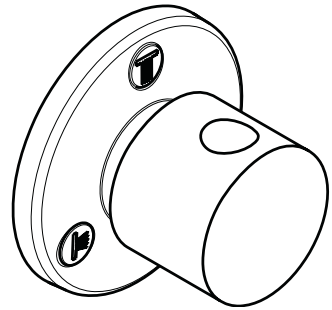

Trio / Quattro S
15932000 / 15932007



Sicherheitshinweise

- Bei der Montage müssen zur Vermeidung von Quetsch- und Schnittverletzungen Handschuhe getragen werden.

Montagehinweise

- Vor der Montage muss das Produkt auf Transportschäden untersucht werden. Nach dem Einbau werden keine Transport- oder Oberflächenschäden anerkannt.

Symbolerklärung



Kein essigsäurehaltiges Silikon verwenden!!



Maße (siehe Seite 12)



Serviceteile (siehe Seite 12)



Reinigung (siehe Seite 13)



Prüfzeichen (siehe Seite 16)

Montage

(siehe Seite 10)



Consignes de sécurité

- Lors du montage, porter des gants de protection pour éviter toute blessure par écrasement ou coupure.

Instructions pour le montage

- Avant son montage, s'assurer que le produit n'a subi aucun dommage pendant le transport. Après le montage, tout dommage de transport ou de surface ne pourra pas être reconnu.

Description du symbole



Ne pas utiliser de silicone contenant de l'acide acétique!!



Dimensions (voir pages 12)



Pièces détachées (voir pages 12)



Nettoyage (voir pages 13)



Classification acoustique et débit (voir pages 16)

Montage

(voir pages 10)



Safety Notes

- Gloves should be worn during installation to prevent crushing and cutting injuries.

Installation Instructions

- Prior to installation, inspect the product for transport damages. After it has been installed, no transport or surface damage will be honoured.

Symbol description



Do not use silicone containing acetic acid!!



Dimensions (see page 12)



Spare parts (see page 12)



Cleaning (see page 13)



Test certificate (see page 16)

Assembly

(see page 10)



Indicazioni sulla sicurezza

- Durante il montaggio, per evitare ferite da schiacciamento e da taglio bisogna indossare guanti protettivi.

Istruzioni per il montaggio

- Prima del montaggio è necessario controllare che non ci siano stati danni durante il trasporto. Una volta eseguito il montaggio, non verranno riconosciuti eventuali danni di trasporto o delle superfici.

Descrizione simbolo



Non utilizzare silicone contenente acido acetico!!



Ingombri (vedi pagg. 12)



Parti di ricambio (vedi pagg. 12)



Pulitura (vedi pagg. 13)



Segno di verifica (vedi pagg. 16)

Montaggio

(vedi pagg. 10)



**Indicaciones de seguridad**

- ⚠ Durante el montaje deben utilizarse guantes para evitar heridas por aplastamiento o corte.

Indicaciones para el montaje

- Antes del montaje se debe examinar el producto contra daños de transporte. Después de la instalación no se reconoce ningún daño de transporte o de superficie.

Descripción de símbolos

No utilizar silicona que contiene ácido acético!!



Dimensiones (ver página 12)



Repuestos (ver página 12)



Limpiar (ver página 13)



Marca de verificación
(ver página 16)

Montaje
(ver página 10)

Veiligheidsinstructies

- ⚠ Bij de montage moeten ter voorkoming van knel- en snijwonden handschoenen worden gedragen.

Montage-instructies

- Vóór de montage moet het product gecontroleerd worden op transportschade. Na de inbouw wordt geen transport- of oppervlakteschade meer aanvaard.

Symboolbeschrijving

Gebruik geen zuurhoudende silicone!!



Maten (zie blz. 12)



Service onderdelen (zie blz. 12)



Reinigen (zie blz. 13)



Keurmerk (zie blz. 16)

Montage
(zie blz. 10)

**Sikkerhedsanvisninger**

- ⚠ Ved monteringen skal der bruges handsker for at undgå kvæstelser og snitsår.

Monteringsanvisninger

- Før monteringen skal produktet kontrolleres for transportskader. Efter monteringen godkendes transportskader eller skader på overfladen ikke længere.

Symbolbeskrivelse

Der må ikke benyttes eddikesyreholdig silikone!!



Målene (se s. 12)



Reservedele (se s. 12)



Rengøring (se s. 13)



Godkendelse (se s. 16)

Montering
(se s. 10)

Avisos de segurança

- ⚠ Durante a montagem devem ser utilizadas luvas de protecção, de modo a evitar ferimentos resultantes de entalamentos e de cortes.

Avisos de montagem

- Antes da montagem deve-se controlar o produto relativamente a danos de transporte. Após a montagem não são aceites quaisquer danos de transporte ou de superfície.

Descrição do símbolo

Não utilizar silicone que contenha ácido acético!!



Medidas (ver página 12)



Peças de substituição (ver página 12)



Limpeza (ver página 13)



Marca de controlo (ver página 16)

Montagem
(ver página 10)



Wskazówki bezpieczeństwa

△ Aby uniknąć zranień na skutek zgniecenia lub przecięcia, podczas montażu należy nosić rękawice ochronne.

Wskazówki montażowe

- Przed montażem należy skontrolować produkt pod kątem szkód transportowych. Po montażu nie widać żadnych szkód transportowych ani szkód na powierzchni.

Opis symbolu



Nie stosować silikonów zawierających kwas octowy!!



Wymiary (patrz strona 12)



Części serwisowe (patrz strona 12)



Czyszczenie (patrz strona 13)



Znak jakości (patrz strona 16)

Montaż

(patrz strona 10)



Bezpečnostní pokyny

△ Pro zabránění řezným zraněním a pohmožděním je nutné při montáži nosit rukavice.

Pokyny k montáži

- Před montáží je třeba produkt zkontrolovat, zda nebyl při transportu poškozen. Po zabudování nebudou uznány žádné škody způsobené transportem nebo poškozené povrchu.

Popis symbolů



Nepoužívat silikon s obsahem kyseliny octové!!



Rozměry (viz strana 12)



Servisní díly (viz strana 12)



Čištění (viz strana 13)



Zkušební značka (viz strana 16)

Montáž

(viz strana 10)



Bezpečnostné pokyny

△ Pri montáži musíte nosiť rukavice, aby ste predišli pomliaždeninám a rezným poraneniam.

Pokyny pre montáž

- Pred montážou musíte produkt skontrolovať, či nebol počas transportu poškodený. Po zabudovaní nebudú uznané žiadne škody spôsobené transportom alebo poškodenia povrchu.

Popis symbolov



Nepoužívať silikon s obsahom kyseliny octovej!!



Rozmery (viď strana 12)



Servisné diely (viď strana 12)



Čistenie (viď strana 13)



Osvedčenie o skúške
(viď strana 16)

Montáž

(viď strana 10)



安全技巧

△ 装配时为避免挤压和切割受伤，必须戴上手套。

安装提示

- 安装前必须检查产品是否受到运输损害。安装后将不认可运输损害或表面损伤。

符号说明



请勿使用含有乙酸的硅胶!!



大小 (参见第页 12)



备用零件 (参见第页 12)



清洗 (参见第页 13)



检验标记 (参见第页 16)

安装

(参见第页 10)





Указания по технике безопасности

- Во время монтажа следует надеть перчатки во избежание прищемления и порезов.

Указания по монтажу

- Перед монтажом следует проверить изделие на предмет повреждений при перевозке. После монтажа претензии о возмещении ущерба за повреждения при перевозке или повреждения поверхностей не принимаются.

Описание символов

 Не применяйте силикон, содержащий уксусную кислоту!

 **Размеры** (см. стр. 12)

 **Комплект** (см. стр. 12)

 **Очистка** (см. стр. 13)

 **Знак технического контроля**
(см. стр. 16)

Монтаж
(см. стр. 10) 

Turvallisuusohjeet

- Asennuksessa on käytettävä käsineitä puristumien ja viiltojen aiheuttamien tapaturmien estämiseksi.

Asennusohjeet

- Ennen asennusta on tarkastettava tuotteen mahdolliset kuljetusvahingot. Asennuksen jälkeen kuljetus- ja pintavaurioita ei hyväksytä.

Merkin kuvaus

 Älä käytä etikkahappopitoista silikonia!!

 **Mitat** (katso sivu 12)

 **Varaosat** (katso sivu 12)

 **Puhdistus** (katso sivu 13)

 **Koestusmerkki** (katso sivu 16)

Asennus
(katso sivu 10) 



Svenska

Säkerhetsanvisningar

- Handskar ska bäras under monteringsarbetet så att man kan undvika kläm- och skärskador.

Monteringsanvisningar

- Det måste undersökas om produkten har transportskador innan den monteras. Efter monteringen accepteras inga transport- eller ytskiktsskador.

Symbolförklaring

 Använd inte silikon som innehåller ättiksyra!!

 **Måtten** (se sidan 12)

 **Reservdelar** (se sidan 12)

 **Rengöring** (se sidan 13)

 **Testsigill** (se sidan 16)

Montering
(se sidan 10) 

Lietuviškai

Saugumo technikos nurodymai

- Apsaugai nuo užspaudimo ir įsijovimo montavimo metu mūvėkite pirštines.

Montavimo instrukcija

- Prieš montuojant būtina patikrinti, ar gaminys nebuvo pažeistas transportavimo metu. Sumontavus pretenzijos dėl transportavimo ir paviršiaus pažeidimų nepriimamos.

Simbolio aprašymas

 Nenaudokite silikono, kurio sudėtyje yra acto rūgšties!!

 **Išmatavimai** (žr. psl. 12)

 **Atsarginės dalys** (žr. psl. 12)

 **Valymas** (žr. psl. 13)

 **Bandymo pažyma** (žr. psl. 16)

Montavimas
(žr. psl. 10) 



Sigurnosne upute

- Prilikom montaže se radi sprječavanja prignječenja i posjekotina moraju nositi rukavice.

Upute za montažu

- Prije montaže mora se provjeriti je li proizvod oštećen prilikom transporta. Nakon ugradnje se ne priznaju nikakve reklamacije koje se odnose na površinska i transportna oštećenja.

Opis simbola

 Nemojte koristiti silikon koji sadrži octenu kiselinu!!

 **Mjere** (pogledaj stranicu 12)

 **Rezervni dijelovi**
(pogledaj stranicu 12)

 **Čišćenje** (pogledaj stranicu 13)

 **Oznaka testiranja**
(pogledaj stranicu 16)

Sastavljanje
(pogledaj stranicu 10) 



Güvenlik uyarıları

- Montaj esnasında ezilme ve kesilme gibi yaralanmaları önlemek için eldiven kullanılmalıdır.

Montaj açıklamaları

- Montaj işleminden önce ürün nakliye hasarları yönünden kontrol edilmelidir. Montaj işleminden sonra nakliye veya yüzey hasarları için sorumluluk üstlenilmemektedir.

Simge açıklaması

 Asetik asit içeren silikon kullanmayın!!

 **Ölçüleri** (bakınız sayfa 12)

 **Yedek Parçalar** (bakınız sayfa 12)

 **Temizleme** (bakınız sayfa 13)

 **Kontrol işareti** (bakınız sayfa 16)

Montajı
(bakınız sayfa 10) 



Instrucțiuni de siguranță

- La montare utilizați mănuși pentru evitarea contuziunilor și tăierii mâinilor.

Instrucțiuni de montare

- Înainte de instalare verificați, dacă produsul prezintă deteriorări de transport. După instalare garanția nu acoperă deteriorările de transport și cele de suprafață.

Descrierea simbolurilor

 Nu utilizați silicon cu conținut de acid acetic!!

 **Dimensiuni** (vezi pag. 12)

 **Piese de schimb** (vezi pag. 12)

 **Curățare** (vezi pag. 13)

 **Certificat de testare** (vezi pag. 16)

Montare
(vezi pag. 10) 



Υποδειξεις ασφαλειας

- Για να αποφύγετε τραυματισμούς κατά τη συναρμολόγηση πρέπει να φοράτε γάντια.

Οδηγίες συναρμολόγησης

- Πριν τη συναρμολόγηση πρέπει να εξεταστεί το προϊόν για ζημιές μεταφοράς. Μετά την εγκατάσταση δεν αναγνωρίζονται ζημιές από τη μεταφορά ή επιφανειακές ζημιές.

Περιγραφή συμβόλων

 Μην χρησιμοποιείτε σιλικόνη που περιέχει οξικό οξύ!!

 **Διαστάσεις** (βλ. Σελίδα 12)

 **Ανταλλακτικά** (βλ. Σελίδα 12)

 **Καθαρισμός** (βλ. Σελίδα 13)

 **Σήμα ελέγχου** (βλ. Σελίδα 16)

Συναρμολόγηση
(βλ. Σελίδα 10) 

**⚠ Varnostna opozorila**

⚠ Pri montaži je treba nositi rokavice, da se prepreči poškodbe zaradi zmečkanja ali urezov.

Navodila za montažo

- Pred montažo je treba izdelek preveriti glede morebitnih transportnih poškodb. Po vgradnji transportne ali površinske poškodbe ne bodo več priznane.

Opis simbola

Ne smete uporabiti silikona, ki vsebuje ocetno kislino!!



Mere (glejte stran 12)



Rezervni deli (glejte stran 12)



Čiščenje (glejte stran 13)



Preskusni znak (glejte stran 16)

Montaža

(glejte stran 10)

**⚠ Ohutusjuhised**

⚠ Kandke paigaldamisel muljumis- ja löikevigastuste vältimiseks kindaid.

Paigaldamisjuhised

- Enne paigaldamist tuleb toodet kontrollida transportdikahjustuste osas. Pärast paigaldamist ei tunnustata enam transporti- või pinnakahjustuste kaebuseid.

Sümbolite kirjeldus

Ärge kasutage äädikhapet sisaldavat silikooni!!



Mõõtude (vt lk 12)



Varuosad (vt lk 12)



Puhastamine (vt lk 13)



Kontrollsertifikaat (vt lk 16)

Paigaldamine

(vt lk 10)

**Latvian****⚠ Drošības norādes**

⚠ Montāžas laikā, lai izvairītos no saspiedumiem un iegriezumiem, nepieciešams nēsāt cimdus.

Norādījumi montāžai

- Pirms montāžas nepieciešams pārbaudīt, vai produktam transportēšanas laikā nav radušies bojājumi. Pēc iebūvēšanas bojājumi, kas radušies transportēšanas laikā, vai virsmas bojājumi netiek atzīti.

Simbolu nozīme

Neizmantojiet silikonu, kas satur etiķskābi!!



Izmērus (skat. lpp. 12)



Rezerves daļas (skat. lpp. 12)



Tīrīšana (skat. lpp. 13)



Pārbaudes zīme (skat. lpp. 16)

Montāža

(skat. lpp. 10)

**⚠ Sigurnosne napomene**

⚠ Prilikom montāže se radi sprečavanja prignječenja i posekotina moraju nositi rukavice.

Instrukcije za montažu

- Pre montaže se mora proveriti da li je proizvod oštećen pri transportu. Nakon ugradnje se ne priznaju nikakve reklamacije koje se odnose na površinska i transportna oštećenja.

Opis simbola

Nemojte koristiti silikon koji sadrži sirćetnu kiselinu!!



Mere (vidi stranu 12)



Rezervni delovi (vidi stranu 12)



Čišćenje (vidi stranu 13)



Ispitni znak (vidi stranu 16)

Montaža

(vidi stranu 10)



**Sikkerhetshenvisninger**

△ Bruk hansker under montasjen for å unngå klem- og kuttskader.

Montagehenviisninger

- Før montasjen skal produktet sjekkes for transportskader. Etter monteringen aksepteres ikke noen transport- eller overflateskader.

Symbolbeskrivelse

Ikke bruk silikon som inneholder eddiksyre!!



Mål (se side 12)



Servicedeler (se side 12)



Rengjøring (se side 13)



Prøvermerke (se side 16)

**Указания за безопасност**

△ При монтажа трябва да се носят ръкавици, за да се избегнат наранявания поради притискане или порязване.

Указания за монтаж

- Преди монтажа продуктът трябва да се провери за транспортни щети. След монтажа не се признават транспортни или повърхностни щети.

Описание на символите

Не използвайте силикон, съдържащ оцетна киселина!!



Размери (вижте стр. 12)



Сервизни части (вижте стр. 12)



Почистване (вижте стр. 13)



Контролен знак (вижте стр. 16)

Montasje

(se side 10)

**Монтаж**

(вижте стр. 10)

**Shqip****عربي****Udhëzime sigurie**

△ Për të evituar lëndimet e pickimeve ose të prerjeve gjatë procesit të montimit duhet që të vishni doreza.

Udhëzime për montimin

- Përpara montimit duhet që produkti të kontrollohet për dëmtime nga transporti. Pas instalimit nuk do të njihet asnjë dëmtim nga transporti ose dëmtim i sipërfaqes.

Përshkrimi i simbolit

Mos përdorni silikon që në përbërje ka acid acetik.!



Përmasat (shih faqen 12)



Pjesët e servisit (shih faqen 12)



Pastrimi (shih faqen 13)



Shenja e kontrollit (shih faqen 16)

تنبيهات الأمان

△ يجب ارتداء قفازات لليد أثناء التركيب لتجنب حدوث أضرار الإنحشار أو الجروح.

تعليمات التركيب

- قبل القيام بعملية التركيب، يجب فحص المنتج للتأكد من خلوه من أية تلفيات ناتجة عن النقل. بعد القيام بعملية التركيب، لن يتم الاعتراف بوجود أية تلفيات سطحية أو تلفيات ناتجة عن عملية النقل.

وصف الرمز

هام! لا تستخدم السليكون الذي يحتوي على أحماض!!



أبعاد (راجع صفحة 12)



قطع الغيار (راجع صفحة 12)



التنظيف (راجع صفحة 13)



شهادة اختبار (راجع صفحة 16)

**التركيب**

(راجع صفحة 10)

**Montimi**

(shih faqen 10)



**⚠ Biztonsági utasítások**

⚠ A szerelésnél a zúzódások és vágási sérülések elkerülése érdekében kesztyűt kell viselni.

Szerelési utasítások

- A szerelés előtt ellenőrizni kell, hogy a terméknek nincs-e szállítási sérülése. Beépítés után a szállítási- vagy felületi sérüléseket nem ismerik el.

Szimbólumok leírása

Ne használjon ecetsavtartalmú szilikon!!



Méretet (lásd a oldalon 12)



Tartozékok (lásd a oldalon 12)



Tisztítás (lásd a oldalon 13)



Vizsgajel (lásd a oldalon 16)

⚠ 安全上の注意

⚠ 施工の際は手を挟んだり怪我をしないように、手袋をはめてください。

施工上の注意

- 製品の施工前に輸送でのダメージがないか確認してください。施工後のキズ等のお申し出はお断りさせて頂いています。

アイコンの説明

酢酸系シリコンをご使用にならないでください!!



寸法 (次のページを参照 12)



スペアパーツ (次のページを参照 12)



お手入れ方法

(次のページを参照 13)



認証について

(次のページを参照 16)

Szerelés

(lásd a oldalon 10) 

施工方法

(次のページを参照 10) 

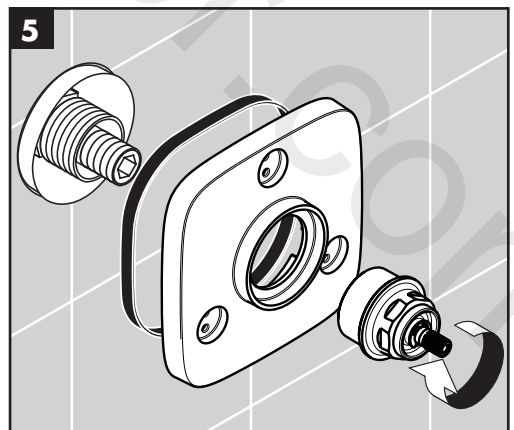
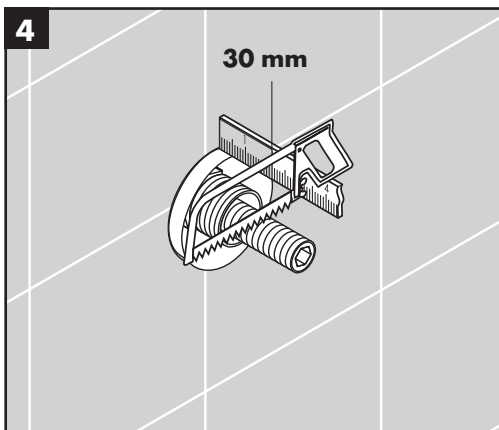
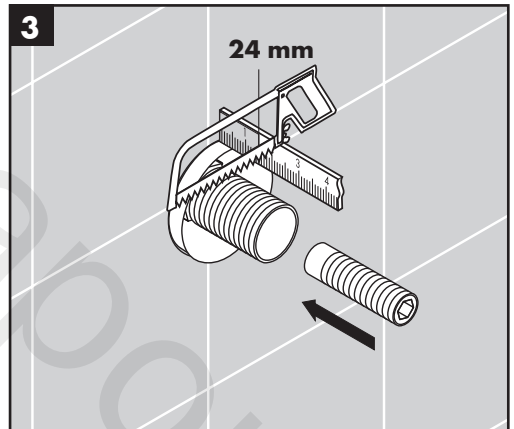
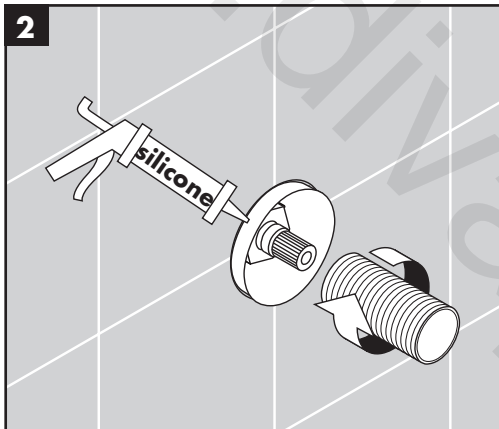
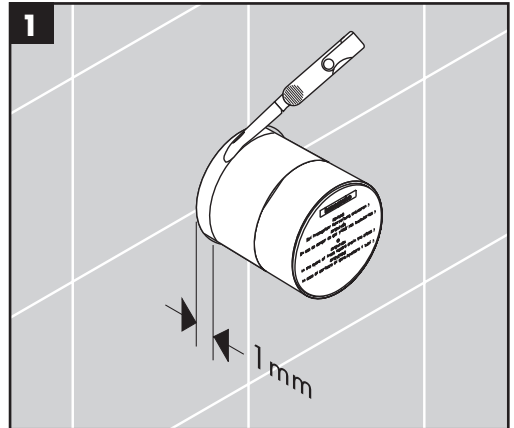
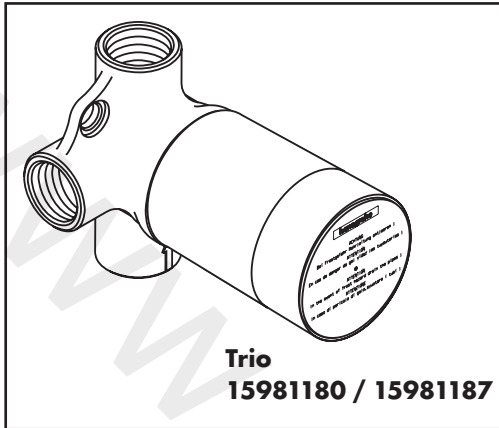

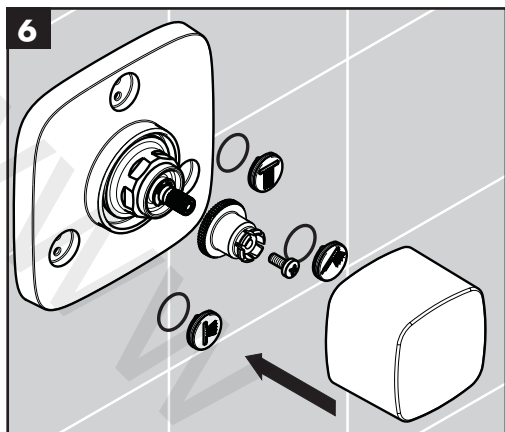

divaport.com



Trio / Quattro S
15932000 / 15932007

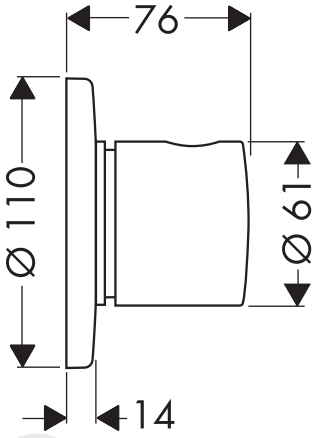

Trio / Quattro S
15932000 / 15932007

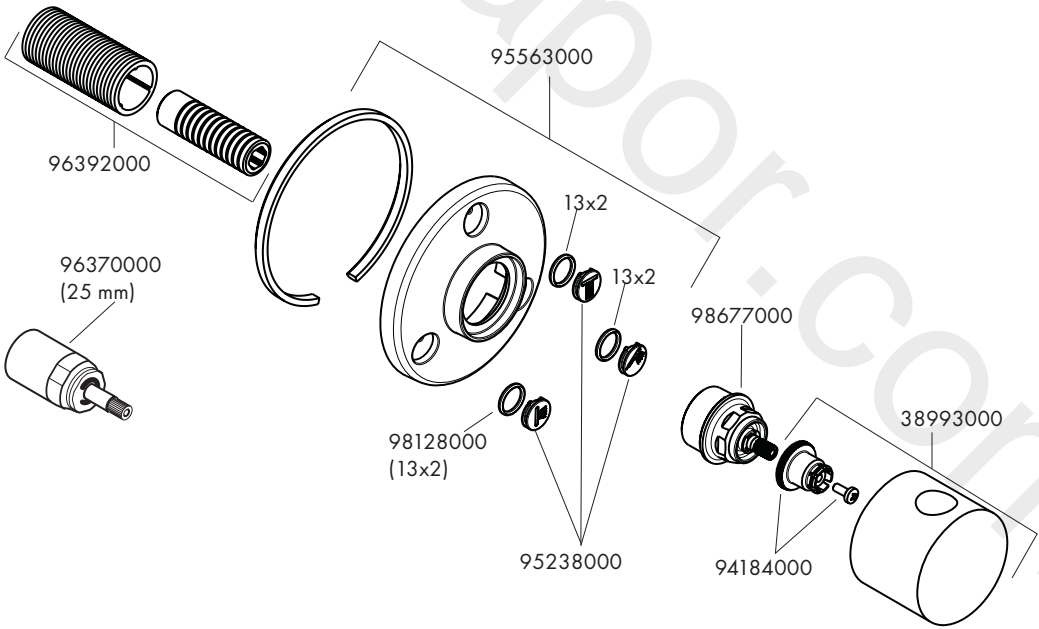



- DE** Reinigungsempfehlung / Garantie / Kontakt
- FR** Recommandation pour le nettoyage / Garanties / Contact
- EN** Cleaning recommendation / Warranty / Contact
- IT** Raccomandazione di pulizia / Garanzia / Contatto
- ES** Recomendaciones para la limpieza / Garantía / Contacto
- NL** Aanbevelingen inzake reiniging / Garantie / Contact
- DK** Rengøringsvejledning / Garanti / Kontakt
- PT** Recomendações de limpeza / Garantia / Contacto
- PL** Zalecenie dotyczące pielęgnacji / Gwarancja / Kontakt
- CS** Doporučení k čištění / Záruka / Kontakt
- SK** Odporúčania pre čistenie / Záruka / Kontakt
- ZH** 清洁指南 / 担保 / 接触
- RU** Рекомендации по очистке / Гарантия / Контакты
- FI** Puhdistussuositus / Takuu / Kosketus
- SV** Rengöringsrekommendationer / Garanti / Contacto
- LT** Valymo rekomendacijos / Garantija / Kontaktai
- HR** Preporuke za čišćenje / Garancija / Kontakt
- TR** Temizleme önerisi / Garanti / Temas
- RO** Recomandări pentru curățare / Garanție / Contact
- EL** Σύσταση καθαρισμού / Εγγύηση / επαφή
- SL** Priporočilo za čiščenje / Garancija / Kontakt
- ET** Puhastussuositused / Garantii / Kontakt
- LV** Tīrīšanas ieteikumi / Garantija / Kontakti
- SR** Preporuke za čišćenje / Garancija / Kontakt
- NO** Anbefaling for rengjøring / Garanti / Kontakt
- BG** Препоръка за почистване / Гаранция / Контакт
- SQ** Këshilla rreth pastrimit / Garancia / Kontakt
- KO** 세정시 권장사항 / 품질보증 / 접촉
- AR** توصيات التنظيف / الضمان (الولايات المتحدة الأمريكية) / اتصال
- HU** Tisztítási tanácsok / Garancia / érintkezés
- JP** お手入れの方法 / 保証について / ご連絡先



[www.hansgrohe.com/
cleaning-recommendation](http://www.hansgrohe.com/cleaning-recommendation)

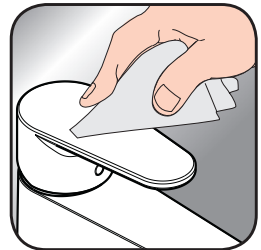

[www.hansgrohe.com/
cleaning-recommendation](http://www.hansgrohe.com/cleaning-recommendation)



[www.hansgrohe.com/
cleaning-recommendation](http://www.hansgrohe.com/cleaning-recommendation)



[www.hansgrohe.com/
cleaning-recommendation](http://www.hansgrohe.com/cleaning-recommendation)

www.divapor.com

www.divapor.com



P-IX

DVGW SINTEF NF



ETA



GODKENDT
TIL DRIKKEVAND

15932000 P-IX 29473/II



www.divapor.com

hansgrohe

Hansgrohe · Auestraße 5 · 9 · D-77761 Schiltach · Telefon +49 (0) 78 36/51-1282 · Telefax +49 (0) 7836/511440
E-Mail: info@hansgrohe.com · Internet: www.hansgrohe.com

12/2020
9.084.65.07