

DE Gebrauchsanleitung / Montageanleitung	2
EN Instructions for use / assembly instructions	4

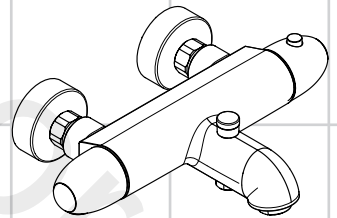

Ecomax
13354000

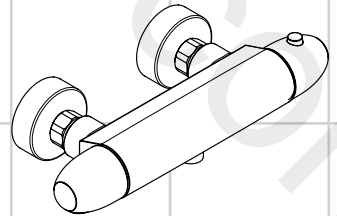

Ecomax
13356000



Sicherheitshinweise

- Bei der Montage müssen zur Vermeidung von Quetsch- und Schnittverletzungen Handschuhe getragen werden.
- Das Produkt darf nur zu Bade-, Hygiene- und Körperreinigungszwecken eingesetzt werden.
- Kinder, sowie Erwachsene mit körperlichen, geistigen und / oder sensorischen Einschränkungen dürfen das Produkt nicht unbeaufsichtigt benutzen. Personen, die unter Alkohol- oder Drogeneinfluss stehen, dürfen das Produkt nicht benutzen.
- Große Druckunterschiede zwischen den Kalt- und Warmwasseranschlüssen müssen ausgeglichen werden.

Montagehinweise

- Vor der Montage muss das Produkt auf Transportschäden untersucht werden. Nach dem Einbau werden keine Transport- oder Oberflächenschäden anerkannt.
- Die Leitungen und die Armatur müssen nach den gültigen Normen montiert, gespült und geprüft werden.
- Die in den Ländern jeweils gültigen Installationsrichtlinien sind einzuhalten.

Thermostat in Verbindung mit Durchlauferhitzern

- Wird eine Handbrause angeschlossen, so muss aus dieser eine eventuell vorhandene Drossel ausgebaut werden.
- Bei Problemen mit dem Durchlauferhitzer oder großen Druckunterschieden muss eine optional erhältliche Drossel (Artikelnummer 97510000) in den Kaltwasserzulauf eingesetzt werden.

Technische Daten

Betriebsdruck:	max. 1 MPa
Empfohlener Betriebsdruck:	0,1 - 0,5 MPa
Prüfdruck:	1,6 MPa
	(1 MPa = 10 bar = 147 PSI)
Heißwassertemperatur:	max. 70 °C
Empfohlene Heißwassertemperatur:	65 °C
Thermische Desinfektion:	max. 70 °C / 4 min
Durchflussleistung Wanneneinlauf:	58 l/min 0,3 MPa
Durchflussleistung Abgang Brause:	18 l/min 0,3 MPa

- Eigensicher gegen Rückfließen
- Das Produkt ist ausschließlich für Trinkwasser konzipiert!

Symbolerklärung



Kein essigsäurehaltiges Silikon verwenden!

max. Safety Function (siehe Seite 10) ≈ 42 °C

Dank der Safety Function lässt sich die gewünschte Höchsttemperatur von z. B. max. 42 °C voreinstellen.



Justierung (siehe Seite 9)

Nach erfolgter Montage muss die Auslauf-temperatur des Thermostaten überprüft werden. Eine Korrektur ist erforderlich wenn die an der Entnahmestelle gemessene Temperatur von der am Thermostaten eingestellten Temperatur abweicht.



Wartung (siehe Seite 11)

- Rückflussverhinderer müssen gemäß DIN EN 1717 regelmäßig in Übereinstimmung mit nationalen oder regionalen Bestimmungen auf ihre Funktion geprüft werden (mindestens einmal jährlich).
- Um die Leichtgängigkeit der Regeleinheit zu gewährleisten, sollte der Thermostat von Zeit zu Zeit auf ganz warm und ganz kalt gestellt werden.



Maße (siehe Seite 8)



Reinigung (siehe Seite 20)



Prüfzeichen (siehe Seite 8)



Serviceteile (siehe Seite 14)



Bedienung (siehe Seite 12)

Störung

Ursache

Abhilfe

Wenig Wasser

- Versorgungsdruck nicht ausreichend
- Schmutzfangsieb der Regeleinheit verschmutzt

- Leitungsdruck prüfen
- Schmutzfangsiebe vor dem Thermostat und auf der Regeleinheit reinigen

- Siebdichtung der Brause verschmutzt

- Siebdichtung zwischen Brause und Schlauch reinigen

Kreuzfluss, warmes Wasser wird bei geschlossener Armatur in die Kaltwasserleitung gedrückt oder umgekehrt

- Rückflussverhinderer verschmutzt / defekt

- Rückflussverhinderer reinigen ggf. austauschen

Auslauftemperatur stimmt nicht mit der eingestellten Temperatur überein

- Thermostat wurde nicht justiert
- Zu niedrige Warmwassertemperatur

- Thermostat justieren
- Warmwassertemperatur erhöhen auf 42 °C bis 65 °C

Temperaturregelung nicht möglich

- Regeleinheit verkalkt

- Regeleinheit austauschen

Durchlauferhitzer schaltet bei Thermostatbetrieb nicht ein

- Schmutzfangsiebe verschmutzt

- Schmutzfangsiebe reinigen / austauschen

- Rückflussverhinderer sitzt fest

- Rückflussverhinderer austauschen

- Drossel in der Handbrause nicht ausgebaut

- Drossel aus der Handbrause entfernen

Brause oder Auslauf tropft

- Schmutz oder Ablagerungen auf dem Dichtsitz, Absperrober teil beschädigt

- Absperrober teil reinigen bzw. austauschen



Montage (siehe Seite 6)



Safety Notes

- △ Gloves should be worn during installation to prevent crushing and cutting injuries.
- △ The product may only be used for bathing, hygienic and body cleaning purposes.
- △ Children as well as adults with physical, mental and/or sensoric impairments must not use this product without proper supervision. Persons under the influence of alcohol or drugs are prohibited from using this product.
- △ The hot and cold supplies must be of equal pressures.

Installation Instructions

- Prior to installation, inspect the product for transport damages. After it has been installed, no transport or surface damage will be honoured.
- The pipes and the fixture must be installed, flushed and tested as per the applicable standards.
- The plumbing codes applicable in the respective countries must be observed.

Thermostatic mixer in conjunction with combination boilers

- If fitting a hand shower remove the water limiter from the shower.
- If the continuous water heater causes any problems, or you have different water pressures you must install a water limiter to the cold supply, (ordered separately, article number 97510000).

Technical Data

Operating pressure:	max. 1 MPa
Recommended operating pressure:	0,1 - 0,5 MPa
Test pressure:	1,6 MPa
	(1 MPa = 10 bar = 147 PSI)
Hot water temperature:	max. 70 °C
Recommended hot water temp.:	65 °C
Thermal disinfection:	max. 70 °C / 4 min
Rate of flow Bath Spout:	58 l/min 0,3 MPa
Rate of flow Shower outlet:	18 l/min 0,3 MPa

- Safety against backflow
- The product is exclusively designed for drinking water!

Symbol description



Do not use silicone containing acetic acid!

max. Safety Function (see page 10)

≈ 42 °C

The desired maximum temperature for example max. 42 °C can be pre-set thanks to the safety function.



Adjustment (see page 9)

After the installation, the output temperature of the thermostat must be checked. A correction is necessary if the temperature measured at the output differs from the temperature set on the thermostat.



Maintenance (see page 11)

- The check valves must be checked regularly according to DIN EN 1717 in accordance with national or regional regulations (at least once a year).
- To guarantee the smooth running of the thermostat, it is necessary from time to time to turn the thermostat from total hot to total cold.



Dimensions (see page 8)



Spare parts (see page 14)



Cleaning (see page 20)



Operation (see page 12)



Test certificate (see page 8)

Special information for UK (see page 15)



Fault	Cause	Remedy
Insufficient water	- Supply pressure inadequate	- Check water pressure (If a pump has been installed check to see if the pump is working).
	- Regulator filter dirty	- Clean filter in front of the mixer and on the MTC-thermo cartridge
	- Shower filter seal dirty	- Clean filter seal between shower and hose
Crossflow, hot water being forced into cold water pipe, or vice versa, when mixer is closed	- Backflow preventers dirty or leaking	- Clean backflow preventers, exchange if necessary
Spout temperature does not correspond with temperature set	- Thermostat has not been adjusted	- Adjust thermostat
	- Hot water temperature too low	- Increase hot water temperature to 42 °C to 65 °C
Temperature regulation not possible	- thermo cartridge calcified	- Exchange thermo cartridge
Instantaneous heater didn't work with thermostat	- Filters are dirty	- Clean the filter / exchange filter
	- check valve hasn't moved back	- Exchange check valves
	- Flow limiter in handshower isn't removed	- Remove flow limiter
Shower or spout dripping	- Dirt or sedimentation on valve seat, shut-off unit damaged	- Clean or exchange shut-off unit



Assembly (see page 6)

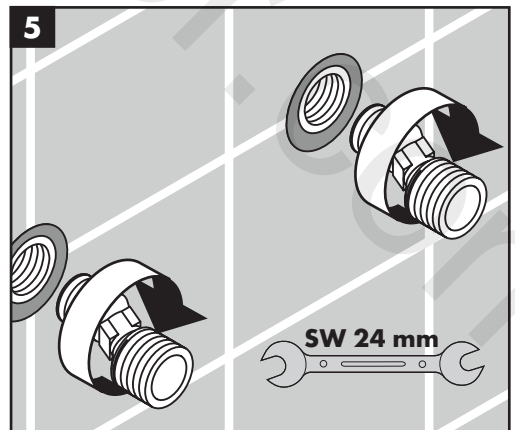
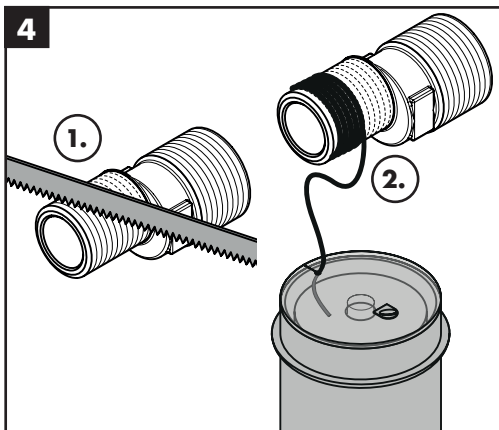
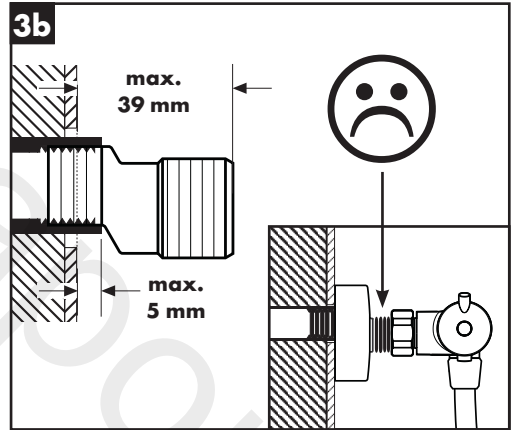
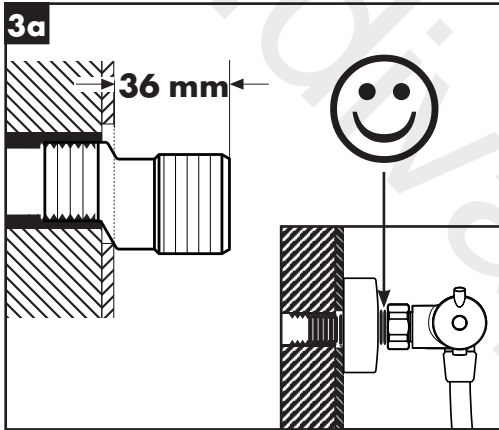
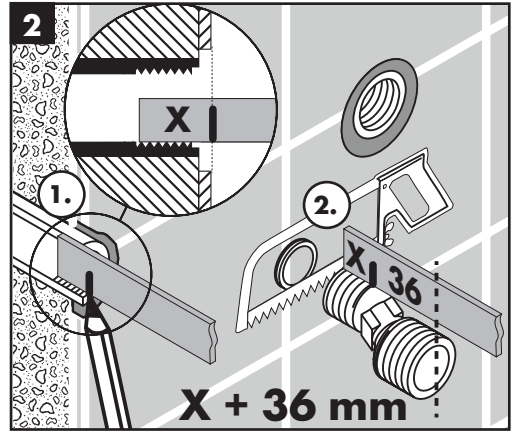
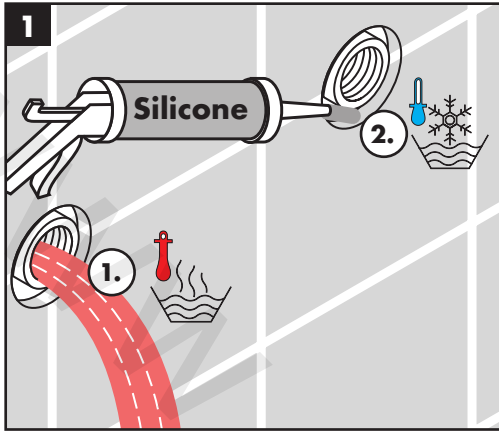

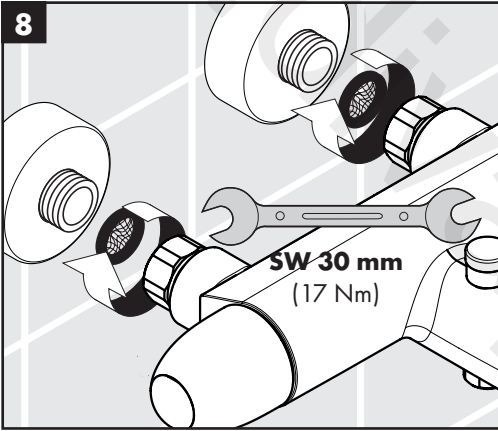
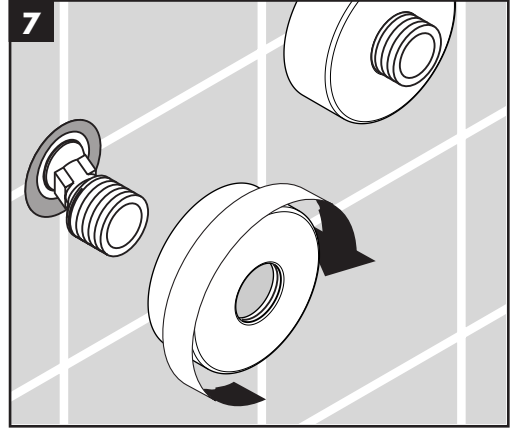
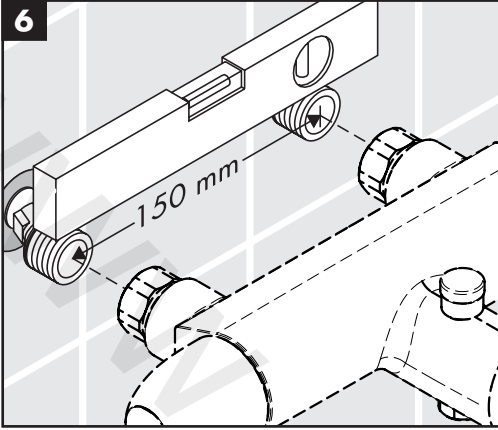



Ecomax
13354000

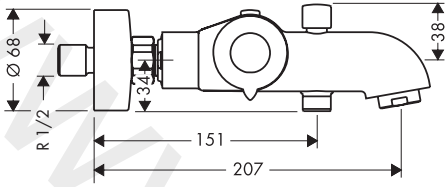

Ecomax
13356000

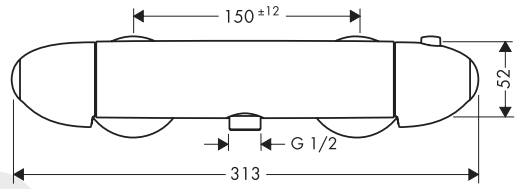
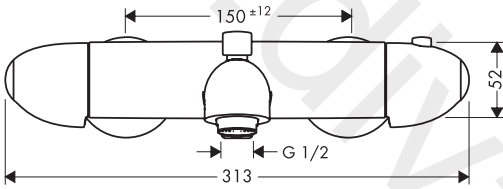
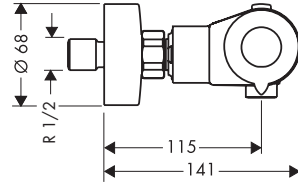

	P-IX	DVGW	SVGW	ACS	WRAS	ETA	KIWA
13354000					X		
13356000					X		

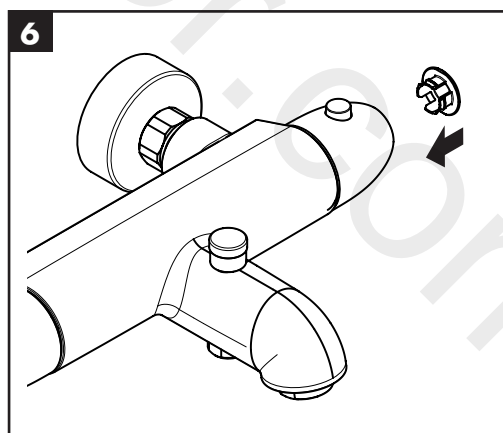
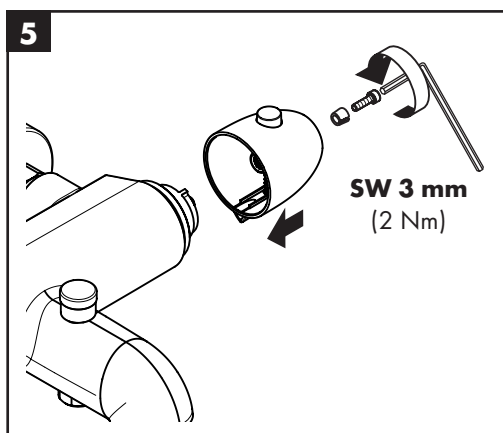
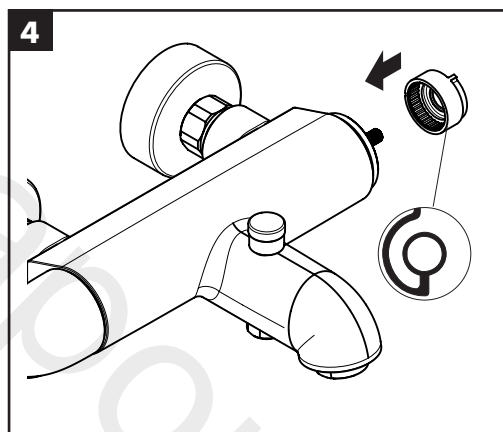
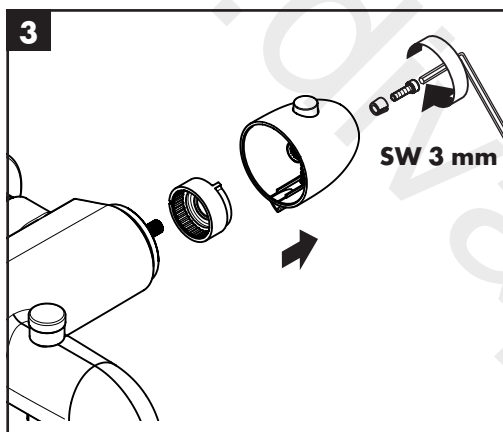
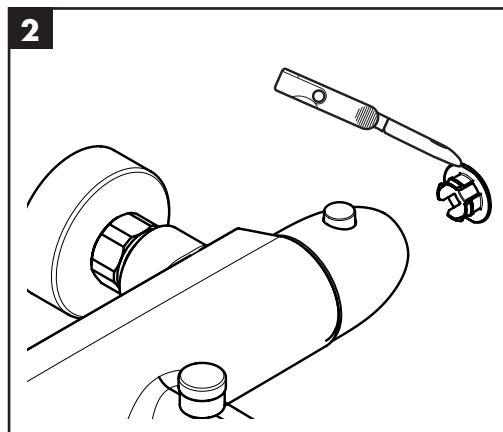
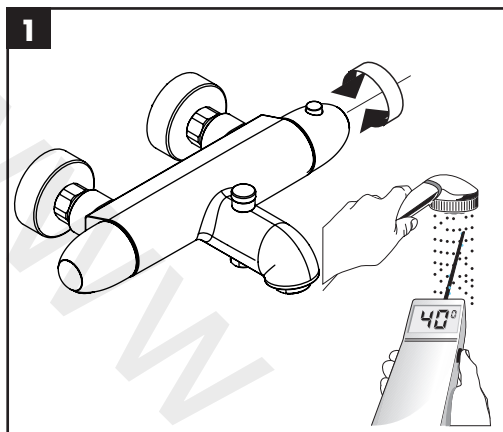

max.
≈ 42° C

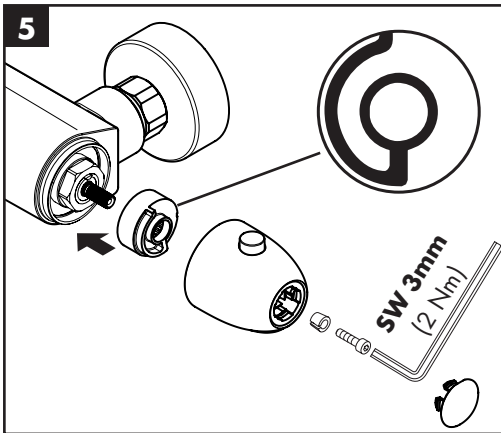
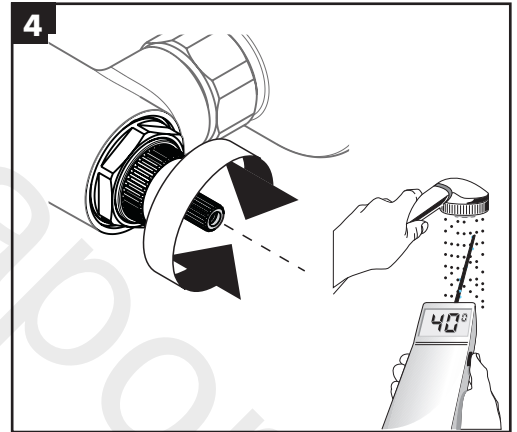
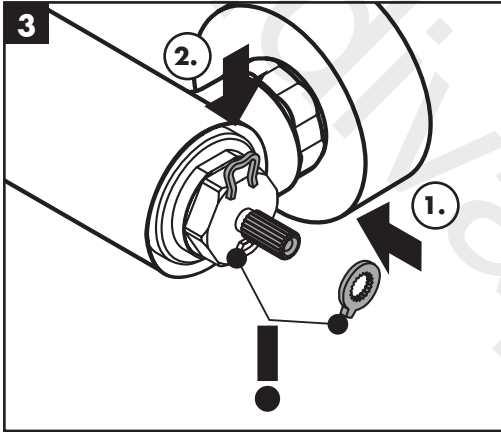
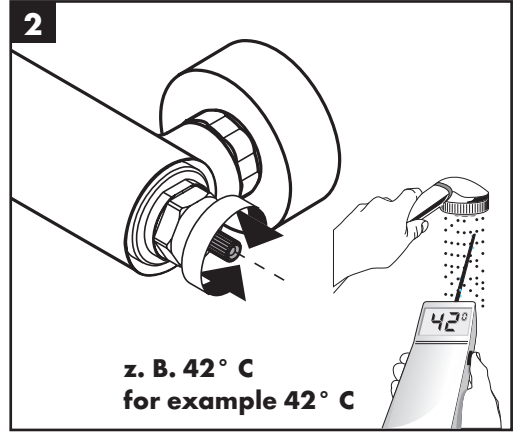
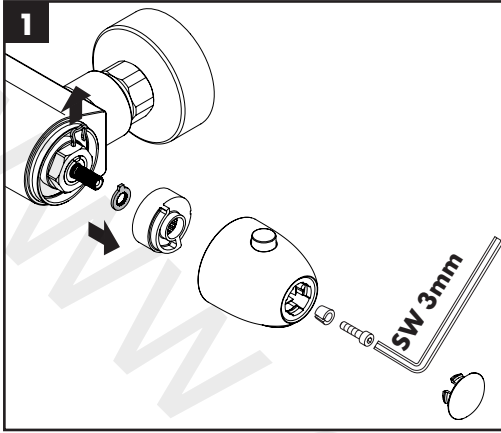

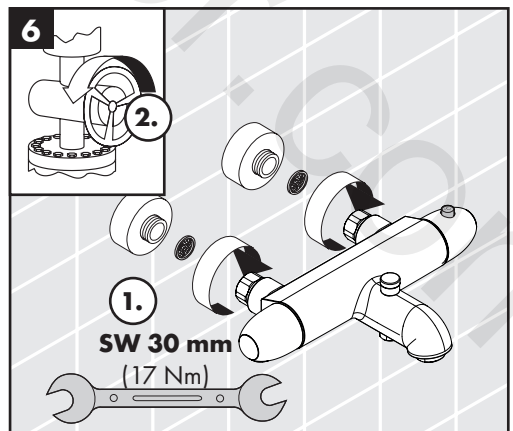
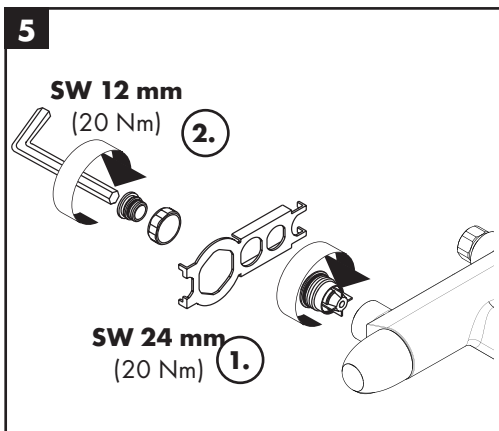
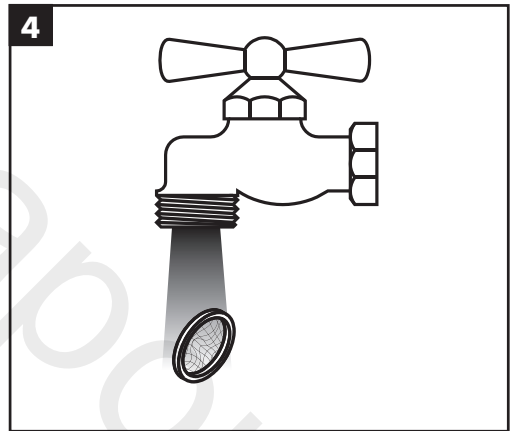
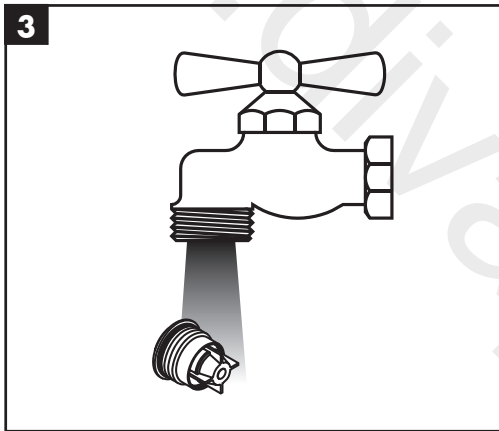
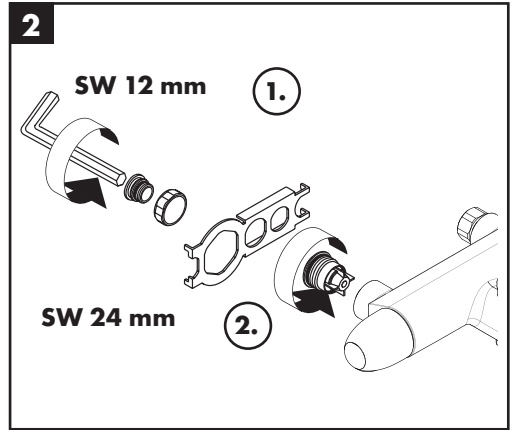
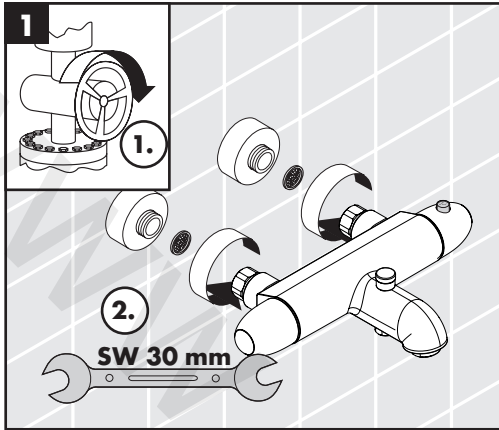

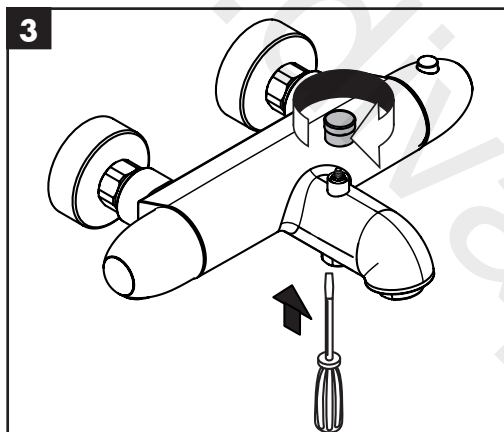
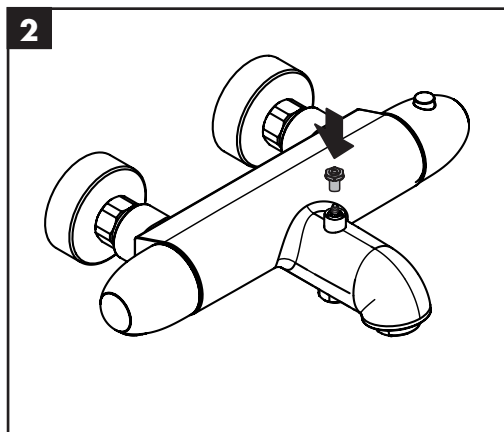
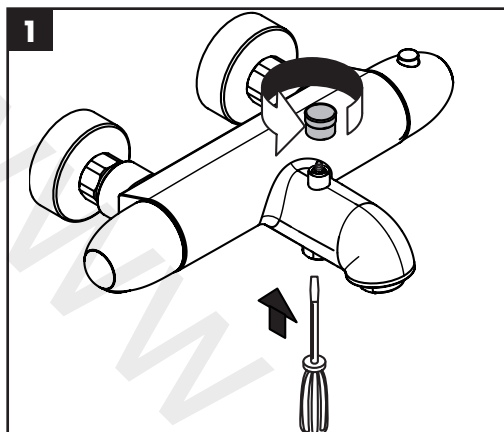

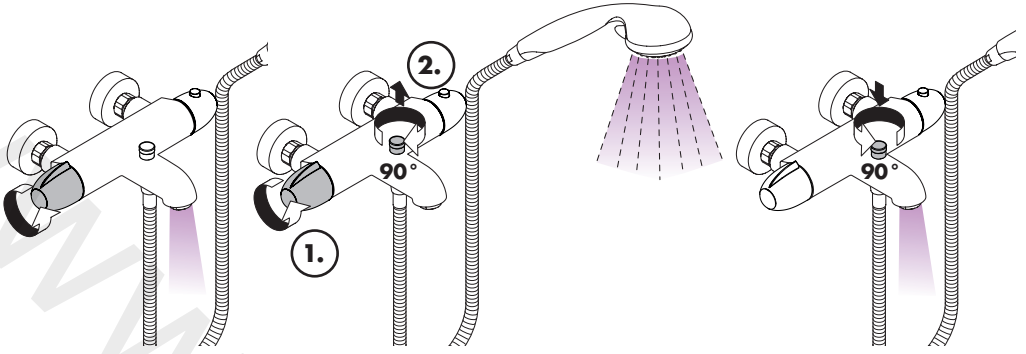

öffnen / open

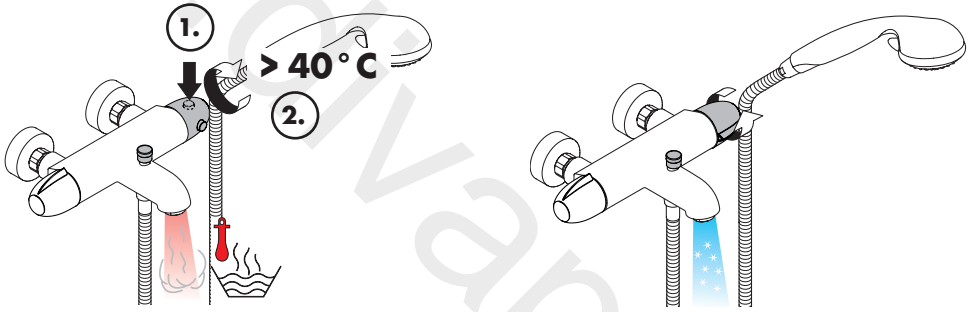

warm / hot

kalt / cold

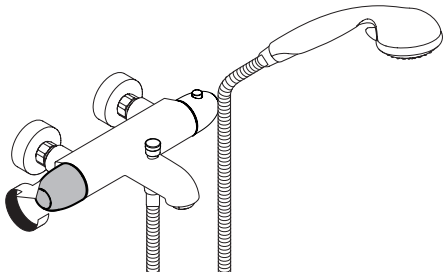

schließen / close



Ecomax
13354000

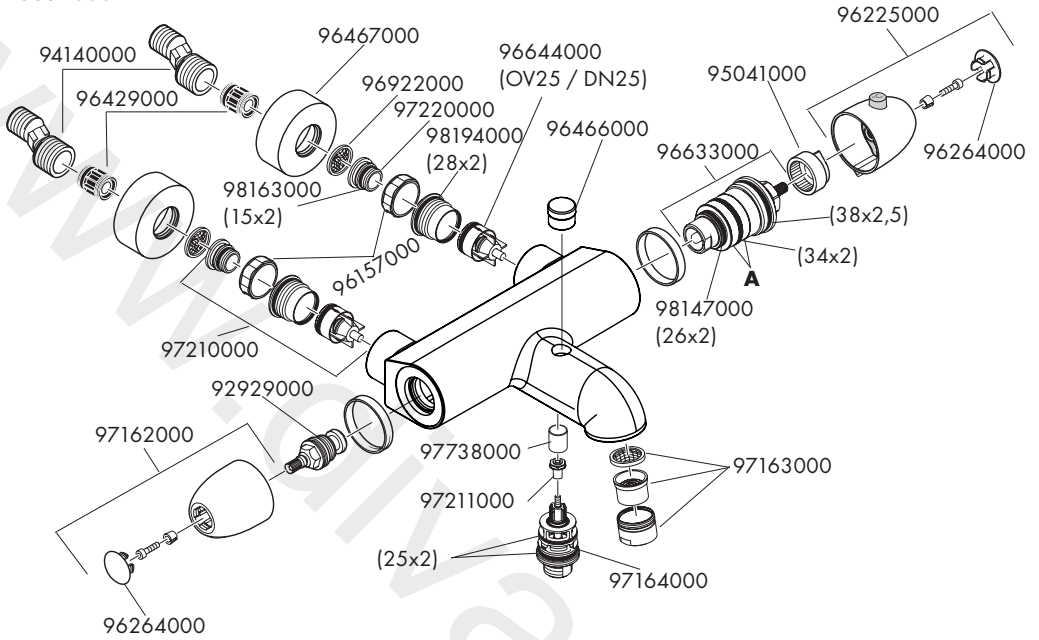

Ecomax
13356000

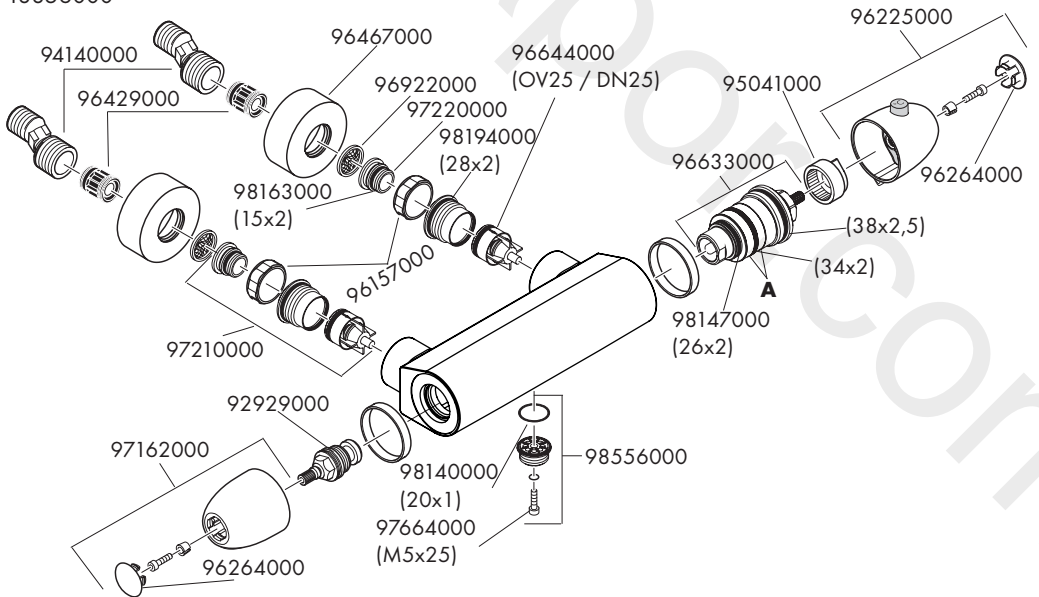



On the following pages 16 - 21 you can find important information only for the installation in UK

Safety and Important Information

Hansgrohe products are safe provided they are installed, used and maintained in accordance with these instructions and recommendations.

Please read these instructions thoroughly and retain for future use.

The plumbing installation of this thermostat mixing valve must comply with the requirements of UK Water Regulations/Bylaws (Scotland), Building Regulations or any other regulations specified by the local Water Authority and supplier.

The installation of thermostatic mixing valves must comply with the requirements of the Water Supply (Water Fittings) Regulations 1999.

We strongly recommend that you use a plumber registered with or a member of an Association:

Chartered Institute of Plumbing and Heating Engineering (CIPHE)
Water Industry Approved Plumber Scheme (WIAPS)

Dispose of plastic bags carefully

Keep children well away from the work area.

Check for hidden pipes and cables in the wall before drilling holes.

The unit must be mounted on a finished waterproofed wall surface (usually tiles).

If you are using power tools (e.g. to drill holes) wear safety glasses and always disconnect tools from the power supply after use.

Do not operate the shower unit if the hand shower or spray hose has been damaged or is blocked.

Do not block the flow of water from the hand shower, by placing it on your hand or any other part of your body or foreign object.

The thermostatic unit should be serviced annually by a qualified person to ensure maximum safety during use.

The thermostatic mixing valve will be installed in such a position that maintenance of the TMV and its valves and the commissioning and testing of the TMV can be undertaken.

The mixer is fitted with check valves (page 14 pos. 96644000). There are filters on the thermostatic element too (page 14 pos. A and 96922000).

The fitting of isolation valves is required (preferred location page 17 Installation Requirements)

Technical Hotline for UK only **01372465655**

E-mail for UK only

Technical@hansgrohe.co.uk

(Diese Servicehotline ist nur für das Vereinigte Königreich Großbritannien, nicht z. B. für Deutschland)

Technical Data

This thermostatic valve will suit supplies of:

13354000: High pressure (HP-S/ T41) / Low pressure (LP-S)

13356000: High pressure (HP-S) / Low pressure (LP-S)

Operating pressure:	max. 10 bar
Recommended operating pressure:	0.2 - 5 bar
Test pressure:	16 bar
Hot water temperature:	max. 80 °C
Recommended hot water temp.:	65 °C
Rate of flow from bath spout:	58 l/min. @ 3 bar
Rate of flow from shower outlet:	18 l/min. @ 3 bar
Maximum outlet temperature:	43 °C +/-*
Safety check:	40 °C
Hot water connection:	Left hand
Cold water connection:	Right hand
Minimum difference between hot water and mixed water temperature:	6 K
Hot and cold supply pressure should be balanced	

Mixed water temperature

Application	Mixed water temperature (at point of discharge).
Shower	41 °C max.
Washbasin	41 °C max.
Bath (44 °C fill)	44 °C max.
Bath (46 °C fill)	46 °C max.

* For preset outlet temperature adjustment – See page 10.

NB. If a water supply is fed by gravity then the supply pressure should be verified to ensure the conditions of use are appropriate for the valve. Valves operating outside of these supply conditions cannot be guaranteed to operate as a TMV2 or TMV3 valve.

Recommended outlet temperatures

The BuildCert TMV scheme recommends the following set maximum mixed water outlet temperatures for use in all premises:

- 44 °C for bath fill but see notes below;
- 41 °C for showers;
- 41 °C for washbasins.

The mixed water temperatures must never exceed 46 °C. The maximum mixed water temperature can be 2 °C above the recommended maximum set outlet temperatures.

Note: 46 °C is the maximum mixed water temperature from the bath tap. The maximum temperature takes account of the allowable temperature tolerances inherent in thermostatic mixing valves and temperature losses in metal baths. It is not a safe bathing temperature for adults or children. The British Burns Association recommends 37 to 37.5 °C as

a comfortable bathing temperature for children. In premises covered by the Care Standards Act 2000, the maximum mixed water outlet temperature is 43 °C

Supply Conditions TMV2

Operating pressure range	High pressure	Low pressure
Maximum static pressure - bar	10	10
Flow pressure, hot and cold - bar	0.5 to 5	0.1 to 1
Hot supply temperature - °C	55 to 65	55 to 65
Cold supply temperature - °C	5 to 25	5 to 25

Supply Conditions TMV3

Operating pressure range	High pressure	Low pressure
Maximum static pressure - bar	10	10
Flow pressure, hot and cold - bar	1 to 5	0.2 to 1
Hot supply temperature - °C	52 to 65	52 to 65
Cold supply temperature - °C	5 to 20	5 to 20

Installation Requirements

This thermostatic mixer valve must be installed in compliance with current Water Regulations. If you have any doubts about the Water Regulation requirements contact your local water services provider or use the services of a professional plumber.

The thermostatic mixing valve must be installed in a position that is easily accessible for commissioning and future servicing.

This mixer valve is suitable for use with the following water supply systems:

- Gas Combination Boiler (multi-point) 1.0 - 10 bar*
- Unvented System (pressure balanced) 1.0 - 10 bar
- Pumped System 1.0 - 10 bar

IMPORTANT: If you install this mixer with a gravity fed system, there must be a minimum head (vertical distance) from the underside of the cold water storage tank to the showerhead position of at least 5 metre.

Before connecting the mixer, water should be flushed through the system to remove all debris that might otherwise damage the valve.

* If pressure is in excess of 3.5 bar, a pressure-reducing valve should be fitted.

KEY



Isolating valve



Reducing valve



Mixer Valve



Pump

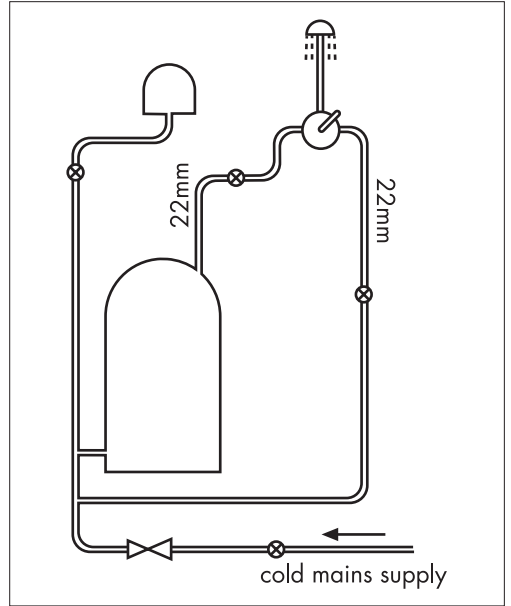

Unvented System (pressure balanced)

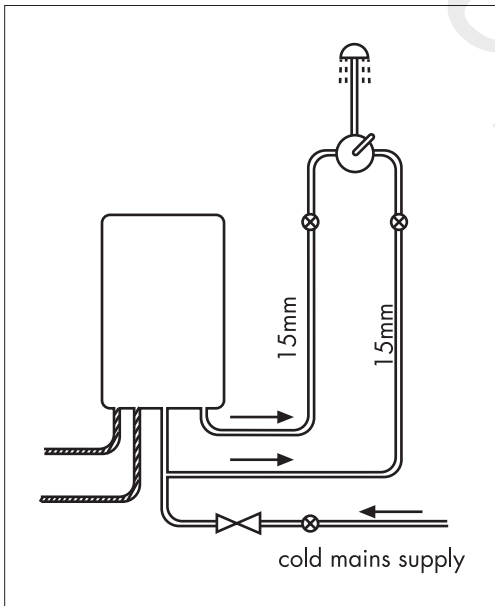

Gas Combination Boiler (multi-point)

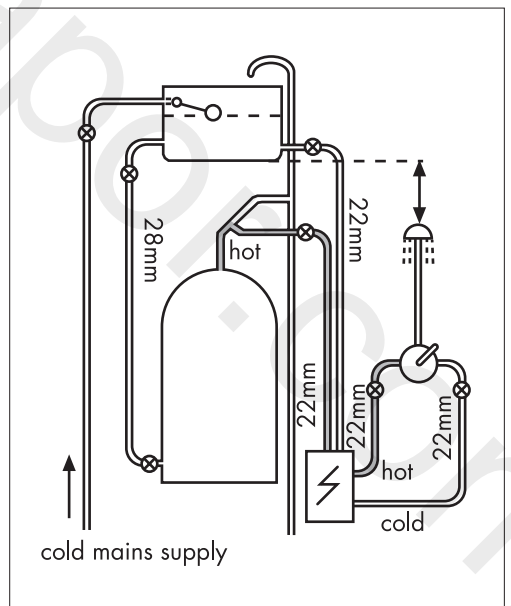

Pumped System

Commissioning and in-service tests

Commissioning

Purpose

Since the installed supply conditions are likely to be different from those applied in the laboratory tests it is appropriate, at commissioning, to carry out some simple checks and tests on each mixing valve to provide a performance reference point for future in-service tests.

Procedure

1. Check that:
 - a) the designation of the thermostatic mixing valve matches the intended application
 - b) the supply pressures are within the range of operating pressures for the designation of the valve
 - c) the supply temperatures are within the range permitted for the valve and by guidance information on the prevention of legionella etc.
2. Adjust the temperature of the mixed water in accordance with the manufacturer's instructions (page 10) and the requirement of the application and then carry out the following sequence:
 - a) record the temperature of the hot and cold water supplies
 - b) record the temperature of the mixed water at the largest draw-off flow rate
 - c) record the temperature of the mixed water at a smaller draw-off flow rate, which shall be measured
 - d) isolate the cold water supply to the mixing valve and monitor the mixed water temperature
 - e) record the maximum temperature achieved as a result of (d) and the final stabilised temperature

NOTE: The final stabilised mixed water temperature should not exceed the values in Table A.

- f) record the equipment, thermometer etc. used for the measurements

temperatures recorded during site tests

Application	Mixed water temperature
Shower	43 °C
Washbasin	43 °C
Bath (44 °C fill)	46 °C
Bath (46 °C fill)	48 °C

The mixed water temperature at terminal fitting should never exceed 46 °C.

If there is a residual flow during the commissioning or the annual verification (cold water supply isolation test), then this is acceptable providing the temperature of the water seeping from the valve is no more than 2 °C above the designated maximum mixed water outlet temperature setting of the valve.

Temperature readings should be taken at the normal flow rate after allowing for the system to stabilise.

The sensing part of the thermometer probe must be fully submerged in the water that is to be tested.

Any TMV that has been adjusted or serviced must be re-commissioned and re-tested in accordance with the manufacturers' instructions.

Table A: Guide to maximum stabilised tem-

In-service tests

Purpose

The purpose of in-service tests is to regularly monitor and record the performance of the thermostatic mixing valve. Deterioration in performance can indicate the need for service work on the valve and/ or the water supplies.

Procedure

1. Carry out the procedure 2. (a) to (e) on page 18 using the same measuring equipment, or equipment to the same specifications.
2. If the mixed water temperature has changed significantly from the previous test results (e.g. > 1 K), record the change and before re-adjusting the mixed water temperature check:
 - a) that any in-line or integral strainers are clean
 - b) any in-line or integral check valves or other anti-backsiphonage devices are in good working order
 - c) any isolating valves are fully open
3. With an acceptable mixed water temperature, complete the procedure 2. (a) to (e) on page 18.
4. If at step 2. (e) on page 18 the final mixed water temperature is greater than the values in Table A and / or the maximum temperature exceeds the corresponding value from the previous test results by more than about 2 K, the need for service work is indicated.

NOTE: In-service tests should be carried out with a frequency which identifies a need for service work before an unsafe water temperature can result. In the absence of any other instruction or guidance, the procedure described in „Frequency of in-service tests“ may be used.

Frequency of in-service tests TMV3*

General

In the absence of any other instruction or guidance on the means of determining the appropriate frequency of in-service testing, the following procedure may be used:

1. 6 to 8 weeks after commissioning carry out the tests given in 2. on page 18.
2. 12 to 15 weeks after commissioning carry out the tests given in 2. on page 18.
3. Depending on the results of 1. and 4. several possibilities exist:
 - a) If no significant changes (e.g. < 1 K) in mixed water temperatures are recorded between commissioning and 1., or between commissioning and 4. the next in-service test can be deferred to 24 to 28 weeks after commissioning.
 - b) If small changes (e.g. 1 to 2 K) in mixed water temperatures are recorded in only one of these periods, necessitating adjustment of the mixed water temperature, then the next in-service test can be deferred to 24 to 28 weeks after commissioning.
 - c) If small changes (e.g. 1 to 2 K) in mixed water temperatures are recorded in both of these periods, necessitating adjustment of the mixed water temperature, then the next in-service test should be carried out at 18 to 21 weeks after commissioning.
 - d) If significant changes (e.g. > 2 K) in mixed water temperatures are recorded in either of these periods, necessitating service work, then the next in-service test should be carried out at 18 to 21 weeks after commissioning.
4. The general principle to be observed after the first 2 or 3 in-service tests is that the intervals of future tests should be set to those which previous tests have shown can be achieved with no more than a small change in mixed water temperature.

***TMV2: The frequency of performing the in-service tests is 1 year maximum.**

Thermostatic Adjustment

Temperature Limitation

The temperature is limited by the safety stop to 40°C. If a higher temperature is required, it is possible to override the safety stop by depressing the safety button.

NB. It is recommended that for **private domestic use** the maximum mixed water temperature be set at the following factory set values:

Shower Mixer 43°C

Bath/Shower 43°C

Temperatures can be set by following the procedures on page 9. This ensures that after correct installation the outlet temperature of the water can never exceed 43°C.

To guarantee a smooth running of the thermostatic element, it is necessary from time to time to turn the thermostat from total hot to total cold. The thermostatic mixer valve should be checked annually by a qualified person to ensure correct operation.

The mixer is fitted with check valves (page 14 pos. 96644000) and filters (page 14 pos. A and 96922000). If the water flow drops the filters need to be cleaned. For that purpose please follow the steps 1 - 8 on page 10.

Calibrating Thermostat

If the temperature reading is different to the showering temperature, follow the steps 1 - 6 on page 8.



[www.hansgrohe.com/
cleaning-recommendation](http://www.hansgrohe.com/cleaning-recommendation)

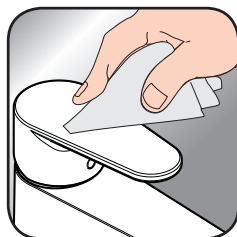

[www.hansgrohe.com/
cleaning-recommendation](http://www.hansgrohe.com/cleaning-recommendation)



[www.hansgrohe.com/
cleaning-recommendation](http://www.hansgrohe.com/cleaning-recommendation)



[www.hansgrohe.com/
cleaning-recommendation](http://www.hansgrohe.com/cleaning-recommendation)

DE Reinigungsempfehlung / Garantie / Kontakt

EN Cleaning recommendation / Warranty / Contact

hansgrohe