



www.diver.com



**PROJECT LINE**

100304788\_N299997960



**PROJECT LINE**

● 100311336



**ROUND**

● 100311337

**noken**  
PORCELANOSA BATHROOMS

Carretera CV-20 km.2 · 12540 Vila-real · Castellón · Spain  
Tel: +34 964 50 64 50 - Fax: +34 964 50 67 93  
e-mail: [noken@noken.com](mailto:noken@noken.com) · [www.noken.com](http://www.noken.com)

**COMPLEMENTOS**



### **Antes de la instalación y la puesta en funcionamiento**

**¡Cuidado!** Los tubos de alimentación tienen que ser enjuagados escrupulosamente antes de instalar el dispositivo de manera que no haya virutas, residuos de soldadura o cáñamo u otras impurezas al interior de los tubos. A través de los tubos no perfectamente enjuagados o de la red hídrica general pueden entrar en el dispositivo unos cuerpos extraños que pueden dañar guarniciones/ juntas tóricas.

Les recomendamos por lo tanto que instalen los filtros en la planta general también.

Recomendamos instalar válvulas reductoras de presión para presiones superiores a las indicadas en la tabla de datos técnicos.

-El respeto de dichas indicaciones, mantiene los derechos de garantía, garantiza las características declaradas de los productos y asegura su perfecta fiabilidad.

### **Before installation and setting to work.**

**Attention!** The feeding pipes have to be rinsed carefully before the installation of the device so that there won't remain shavings, sealing or hemp residues, or other impurities inside the pipes. Through pipes not thoroughly rinsed or through the general water network, in the device foreign bodies can enter that could damage gaskets/ o-ring.

So filters should be installed also on the general system.

We recommend the installation of pressure reducing valves for pressures superior than those indicated in the technical data table.

-Respecting this indications, will maintain the warranty rights, ensures the declared properties of the products and warrant the complete reliability.

### **Avant l'installation et la mise en fonction.**

**Attention!** Les tuyaux d'alimentation doivent être rincés avec soin avant l'installation du dispositif, de sorte que ils ne restent pas de copeaux, des restes de soudage ou de chanvre, ou d'autres impuretés à l'intérieur des tuyaux. A travers les conduites non rincées à fond ou à travers le réseau hydrique général, dans le dispositif peuvent entrer des corps étrangers à même de détériorer les gaines/o-ring.

On recommande ainsi d'installer des filtres également sur le système général.

Nous recommandons d'installer les réducteurs de pression pour des pressions supérieures à indiquées dans le tableau des données techniques.

-Le respect de ces indications, assure les droits de garantie, garantit les caractéristiques déclarées des produits et il en assure la complète fiabilité.

### **Antes da instalação e colocada em funcionamento**

**Cuidado!** Os tubos de alimentação têm que ser cuidadosamente lavados, antes de se instalar o dispositivo de maneira a que não haja chips, resíduos de solda ou canhamo ou outras impurezas no interior dos tubos. Através dos tubos que não estejam cuidadosamente lavados ou através da rede de água geral, podem entrar no dispositivo corpos estranhos que podem danificar as juntas/ o-rings.

Recomendamos por isso que se instalem filtros também na planta geral

Recomendamos a instalação de válvulas reductoras de pressão acima indicados nas pressões da tabela de dados técnicos

Com o cumprimento destas instruções, a garantia permanece, garante as características declaradas dos produtos e garante sua perfeita confiança.



- Lea atentamente estas instrucciones antes de comenzar la instalación.
  - Compruebe el producto por si faltasen piezas o estuviesen dañadas.
  - Cualquier alteración que se realice a la grifería invalidará la garantía.
  - Le recomendamos la instalación por parte de personal cualificado.
  - En nuevas construcciones se deben llenar los sifones de inodoros, lavabos y bidés de agua para evitar que la grifería se oxide por efecto de la subida de gases corrosivos. Se recomienda que el espacio esté muy aireado.
  - Purgar las tuberías antes de la instalación para arrastrar la suciedad.
  - Gracias a un cuidado periódico, se pueden evitar calcificaciones.
  - Residuos de productos de aseo como jabón líquido, champú y gel de ducha, también pueden dañar los materiales.
- 
- Please read these instructions carefully before starting installation and retain it for future reference. Please leave this instructions with the end user.
  - Remove all packaging and check the product for missing parts and damages before starting the installation.
  - Any alterations made to this product and its fittings may infringe the water regulations and will invalidate the guarantee.
  - We strongly recommend the use of a qualified and registered plumber.
  - In new buildings it is recommended to water fill the traps to ensure toxic gases do not corrode the surface of the taps. It is recommended that the room is well ventilated.
  - Thoroughly flush through all pipe work prior to the installation of terminal appliances, e.g. Shower heads, taps, inlet valves, etc.
  - Periodic cleaning and maintenance should be use to avoid the build up of damaging limestone deposits.
  - Bathroom beauty products such as liquid soap, shampoo or shower gels may damage some materials.
- 
- Lire attentivement cette notice avant de commencer l'installation.
  - Vérifier si certaines pièces sont manquantes au abîmées.
  - Toute altération qui sera effectuée à la robinetterie rendra invalide la garantie.
  - Nous recommandons fortement l'installation du produit par du personnel qualifié.
  - Dans le cas de constructions neuves, il faut mettre en eau les WC, lavabos et bidets pour éviter que la robinetterie s'oxyde à cause de gaz corrosif. Nous recommandons de laisser un espace très aéré.
  - Purger les tuyauteries avant l'installation.
  - Grâce à un entretien régulier, on peut éviter la formation de calcaire.
  - Des résidus de produits de toilettes comme le savon liquide, le shampoing et le gel de douche peuvent également endommager les produits.
- 
- Leia atentamente estas instruções antes de iniciar a instalação.
  - Verifique o produto se ele estiver danificado ou se faltarem peças.
  - Qualquer alteração que seja feita à torneira invalidará a garantia.
  - Recomendamos a instalação por pessoal qualificado.
  - Em novas construções devem-se colocar, sifões sanitários, pias e bidés, torneiras de água para prevenir a ferrugem devido ao aumento de gases corrosivos. Recomenda-se que o espaço seja muito arejado.
  - Lavar os tubos antes da instalação para arrastar a sujidade.
  - Com cuidados regulares, pode-se impedir a calcificação.
  - Produtos de higiene pessoal, como sabonete líquido, champô e gel de banho, também pode danificar materiais.

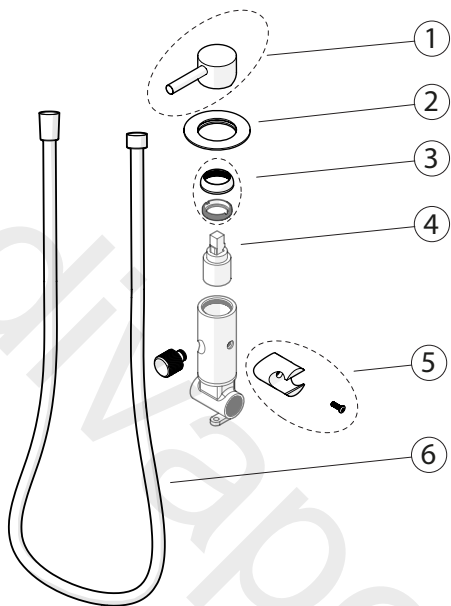

N°	100311336
1	100313699
2	100313705
3	100313706
4	100241940
5	100289364
6	100301987

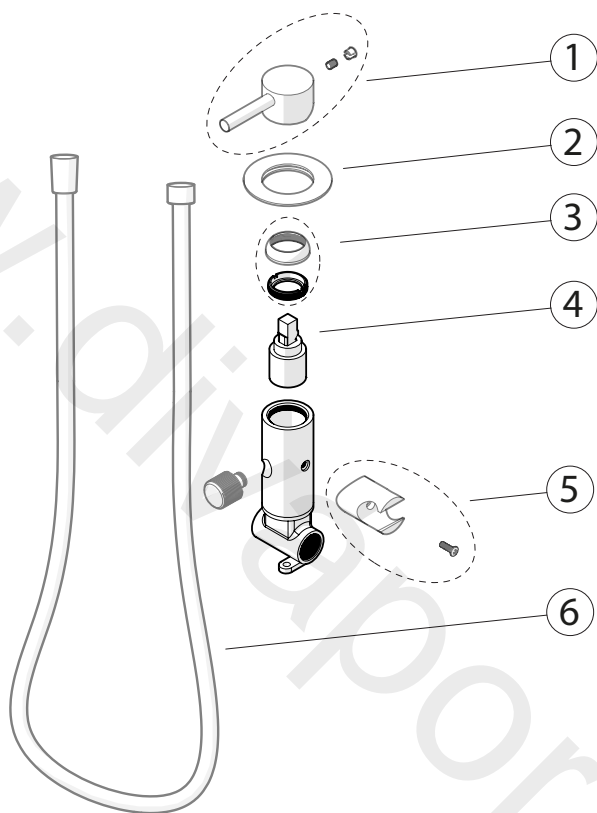

N°	100304788_N299997960
1	-
2	-
3	-
4	100241940_N299998457
5	-
6	-

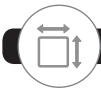

## PROJECT LINE

100304788\_N299997960

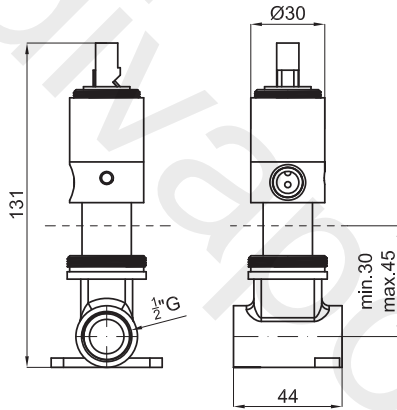



## PROJECT LINE

● 100311336

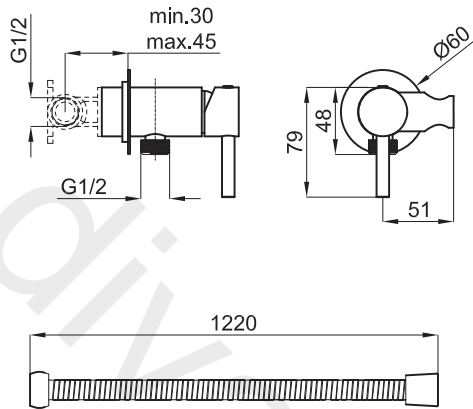

## ROUND

● 100311336

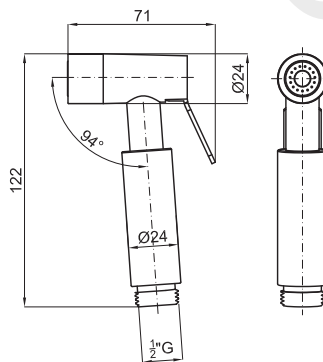

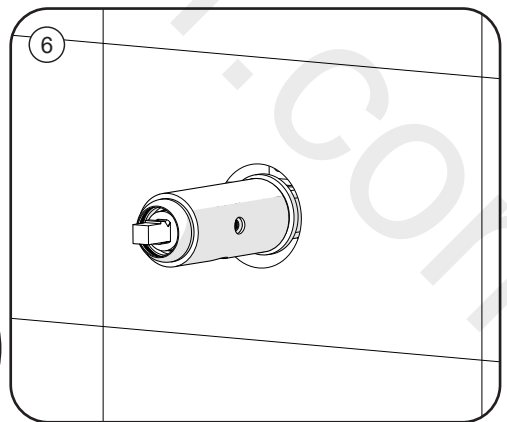
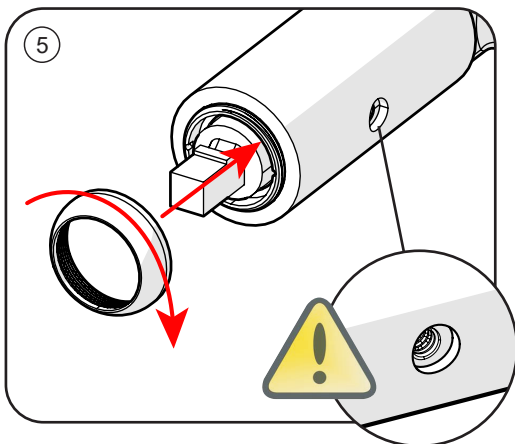
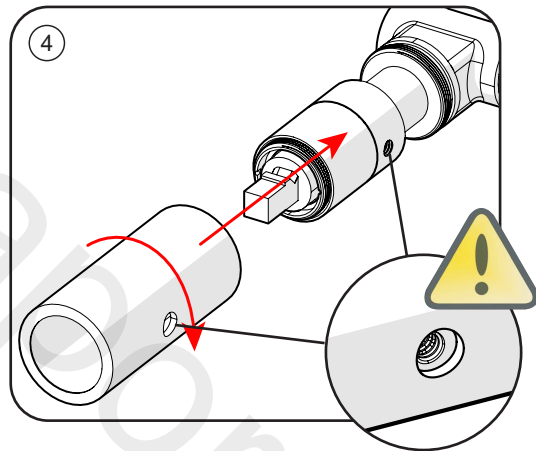
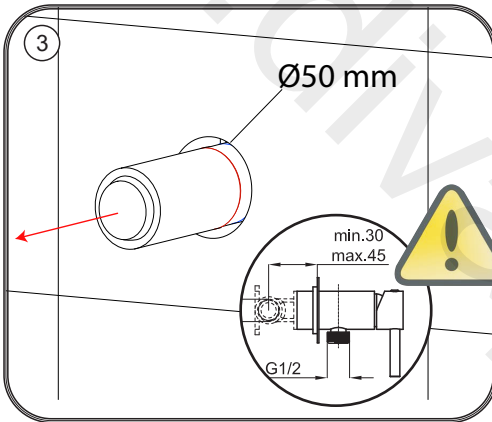
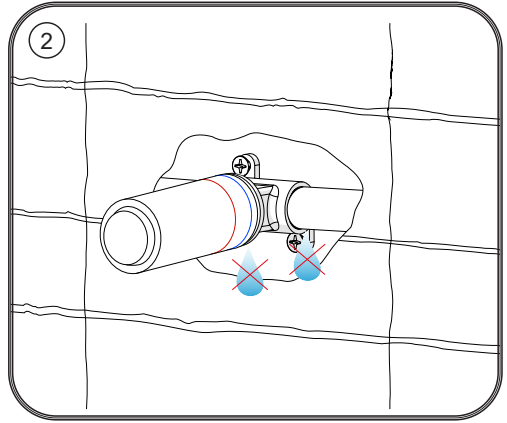
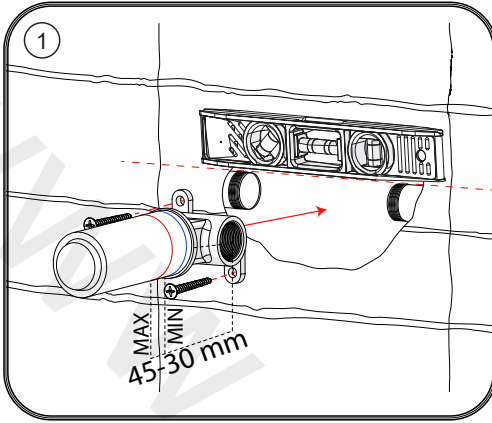

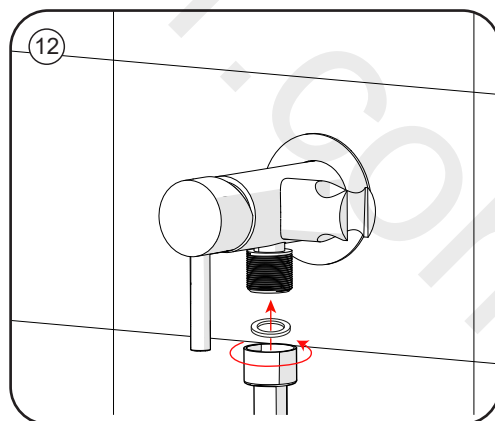
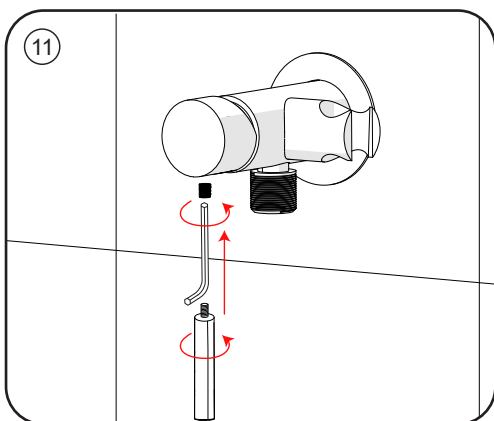
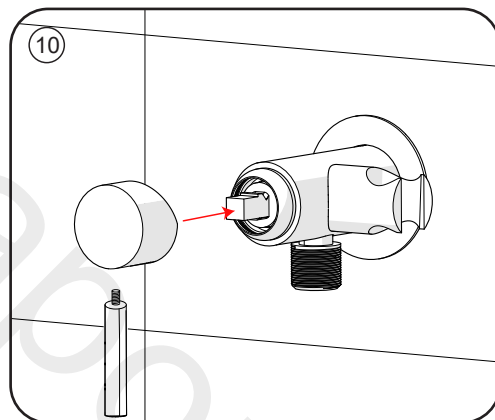
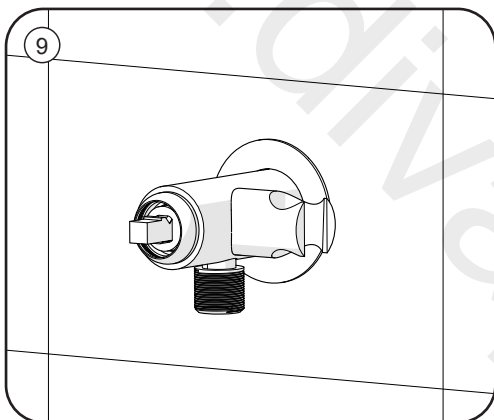
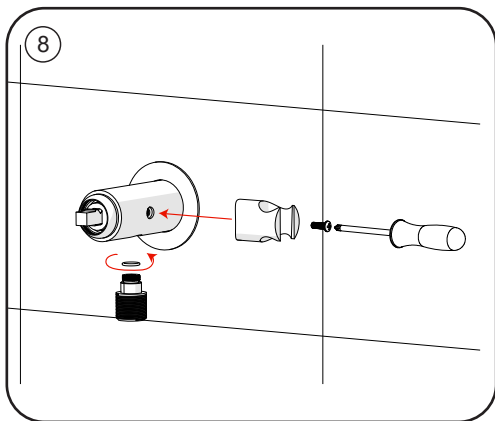
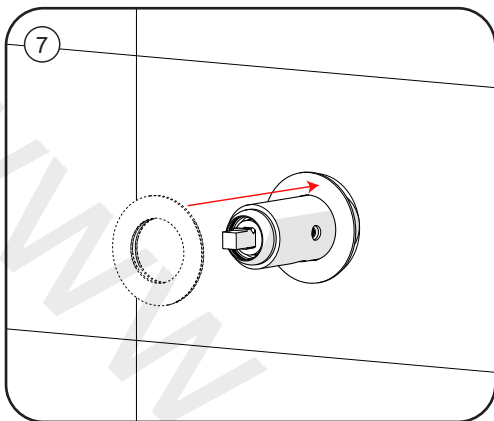

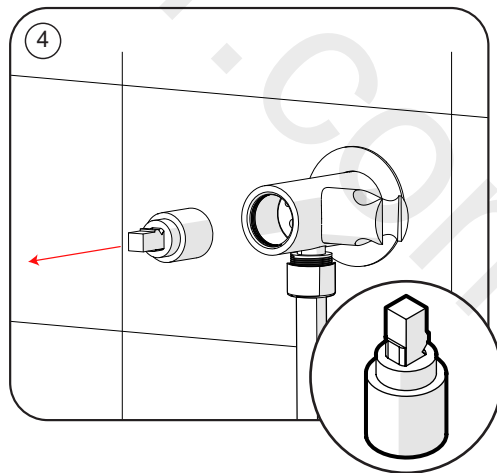
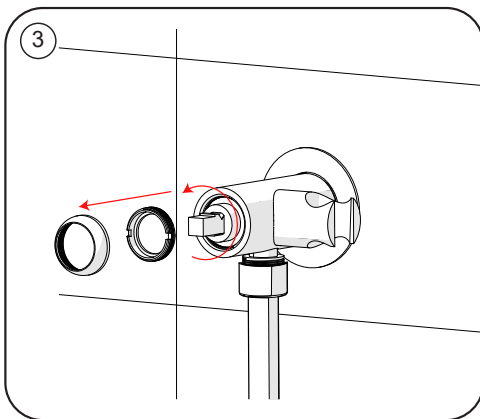
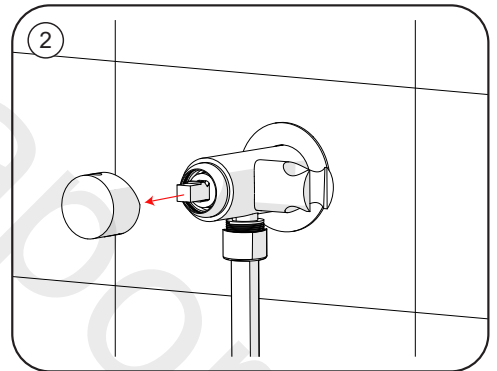
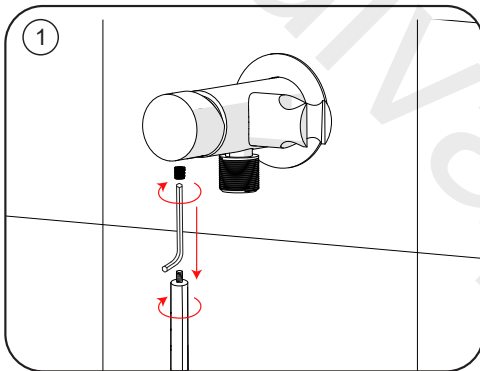
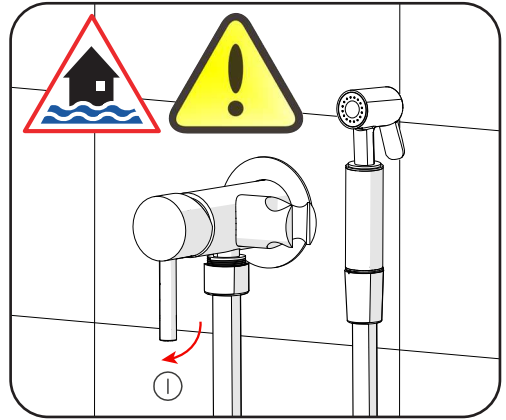
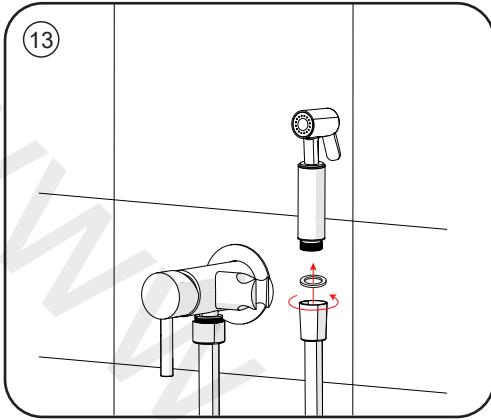

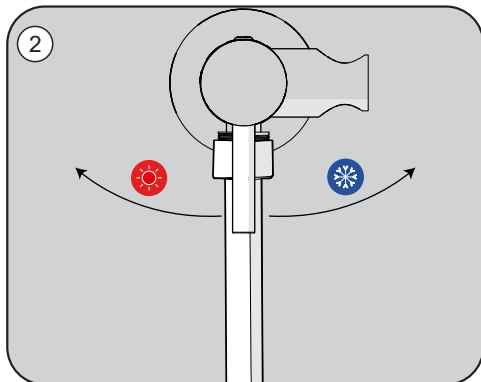
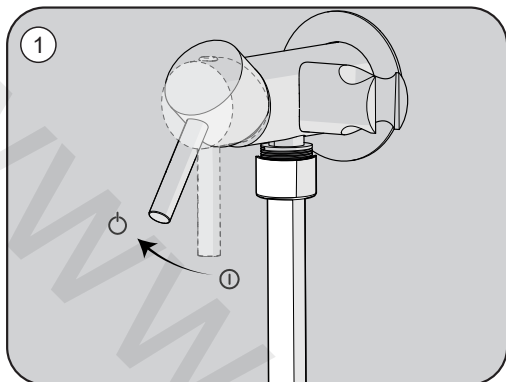



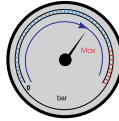

	Min.-Max. 0,5 - 5 bar		Max. 70°C	Mixing system	
	Max. 5 bar		3 bar	Material	Brass
				Coating	chrome nickel
					≥ 0,25 μm ≥ 10 μm

Pressure (Bar)	FLOW RATE (l/min)
0,0	0,0
0,5	2,2
1,0	3,2
2,0	4,7
3,0	5,9
4,0	7,0
5,0	8,8

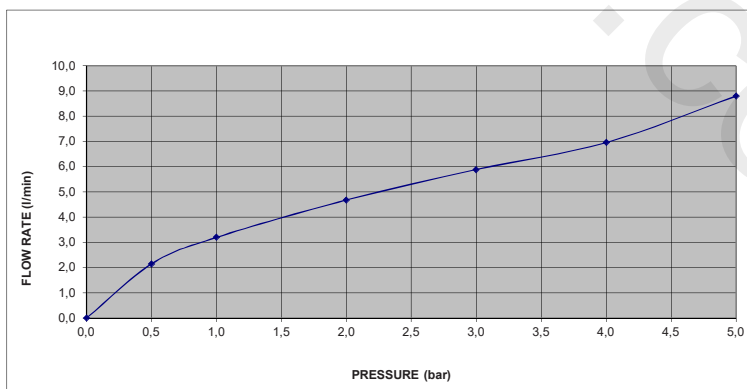

## PORCELANOSA BATHROOMS



[www.noken.com](http://www.noken.com)

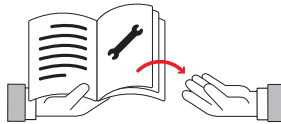

Para consultar la garantía u otra información relativa a este producto, visitar nuestra web:

For a warranty or other information on this product, visit our Web address:

Pour obtenir une garantie ou d'autres informations sur ce produit, visitez notre site web:

Para garantia ou outras informações sobre este produto, visite o nosso site:

Per consultare la garanzia o altre informazioni relative a questo prodotto, visitare il nostro sito Web:

Hinweise zur Garantie und zu sonstigen Einzelheiten zu dem Produkt finden Sie auf unserer Webseite:

Для получения гарантийной или другой информации, связанной с данным продуктом, посетите наш веб-сайт:

Aby zapoznać się z gwarancją lub innymi informacjami związanymi z danym produktem, odwiedź naszą stronę internetową:

关于这个产品的保修及其它信息，请访问我司的网站参看。

تنررتن إلیا یل ع ان عقوم قرا یزء اء اءرلا ؁ءتنءملا اءءب قوقل عءتم یرءا ءءاءول عم یءا وا ءلءافءلا ءءءءرمل