

## Mira Advance Shower Fittings

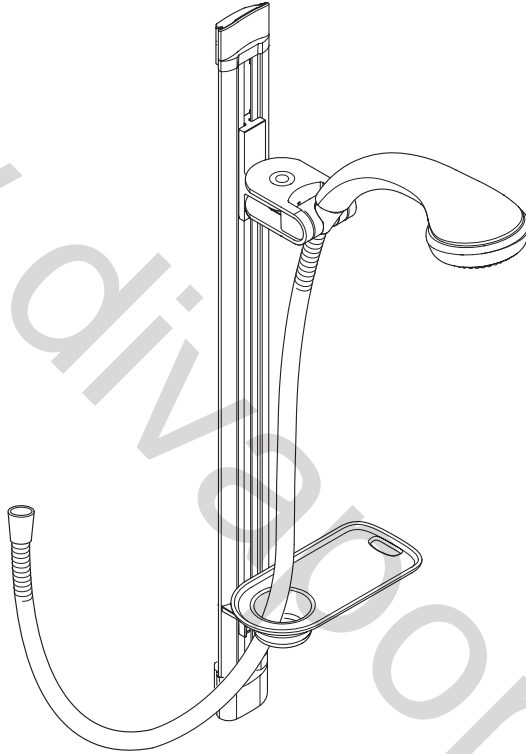

These instructions must be left with the user

Installation and User Guide

*Showering perfection*

**mira**  
SHOWERS

# INTRODUCTION

## Mira Advance Shower Fittings

Mira Advance shower fittings are precision engineered to give a great shower over a range of pressures. The Advance shower fittings can be fitted onto a flat wall or fitted into a corner position, to satisfy and compliment various shower areas.

### Wall Mounted

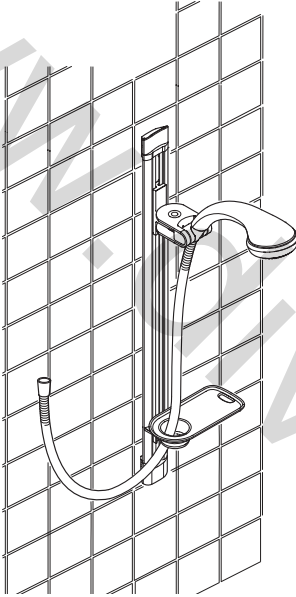

### Corner Mounted

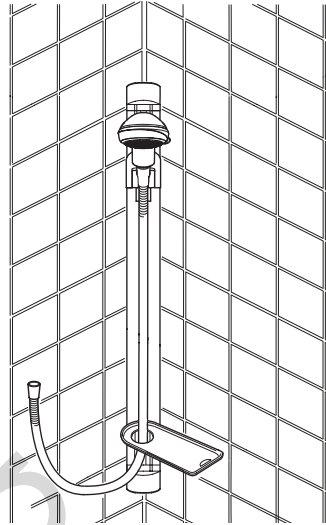

### Product Covered by this Guide:

Advance Complete Fittings - An adjustable spray handset, flexible hose, adjustable clamp bracket assembly, slide rail, hose retaining ring and soap dish. Suitable for connection to surface mounted showers.

### Patents and Design Registration

Design Registraion	000738141-0006
000738141-0007	000738141-0008

If you experience any difficulty with the installation or operation of your new shower fittings, then please refer to "**Fault Diagnosis**", before contacting Kohler Mira Limited. Our telephone and fax numbers can be found on the back cover of this guide.

# SPECIFICATION

## Specifications

Minimum maintained pressure: **6 kPa (0.06 Bar)**.

Maximum maintained pressure: **500 kPa (5.0 bar)**.

**Warning!** Exceeding the stated maximum maintained pressure could result in excessive spray forces and possible damage to the product.

Pressure loss = Pressure difference between the inlet and outlet of the fitting

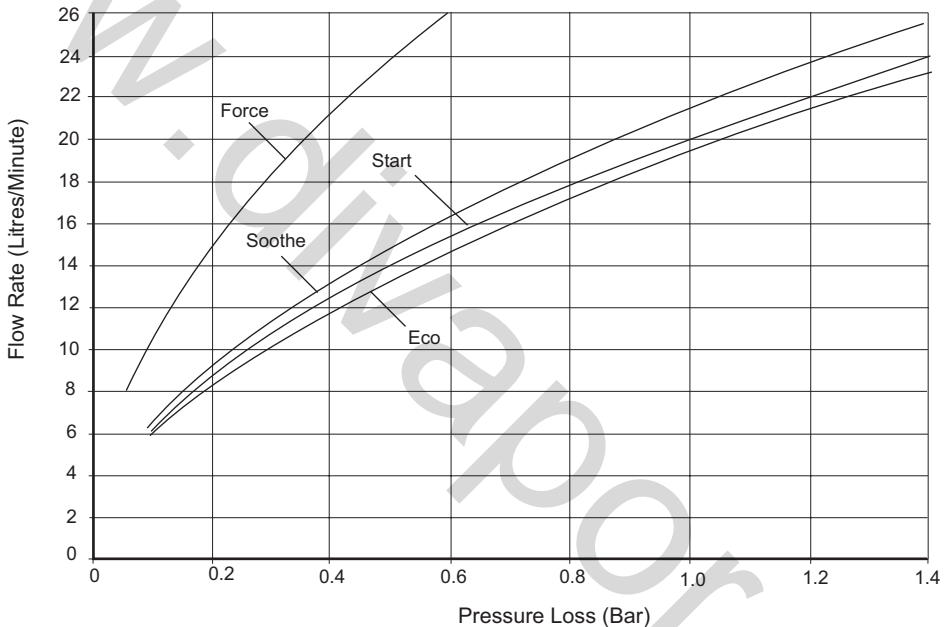

## The Handset

An adjustable spray handset with four different spray actions (Eco, Start, Soothe and Force).

The shower hose terminates in a 1/2" BSP female thread for connection to the outlet of the shower.

# PACK CONTENTS

Tick the appropriate boxes to familiarize yourself with the part names and to confirm that the parts are included.

## Mira Advance Shower Fittings

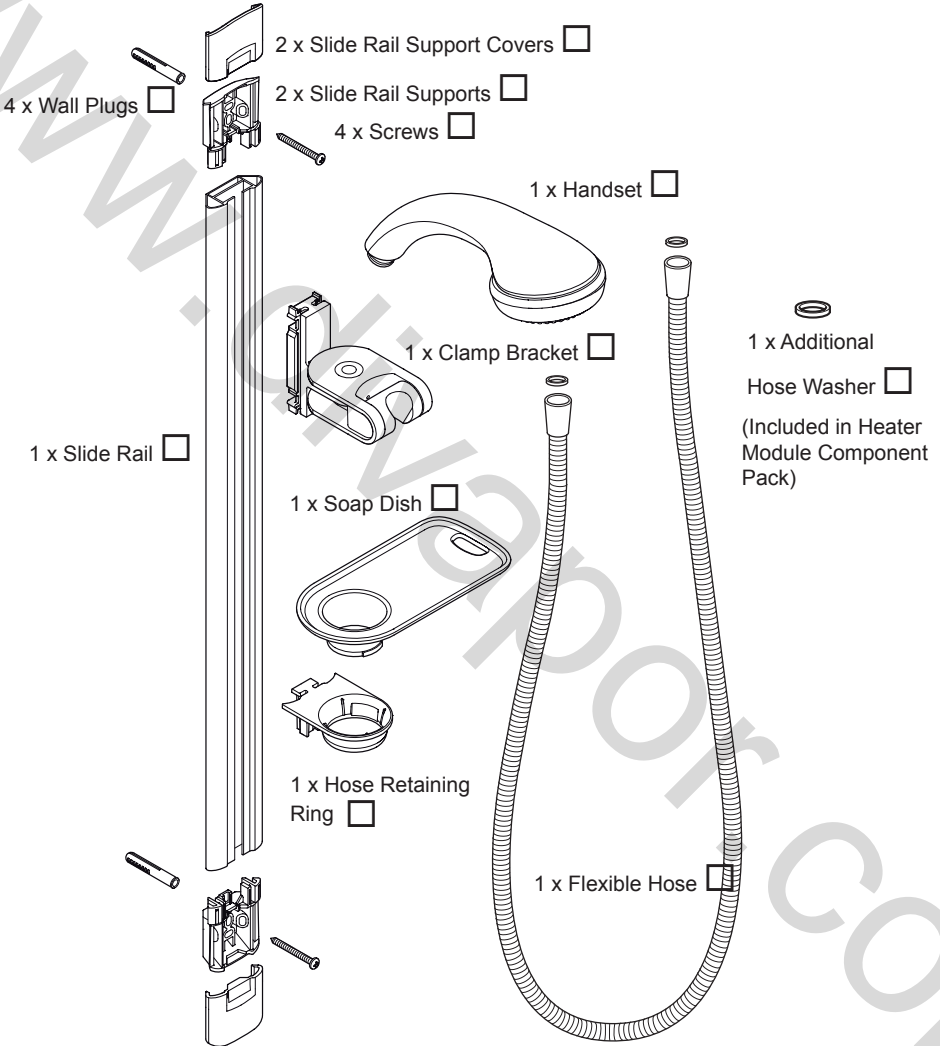

## Documentation

1 x Installation and User Guide

# DIMENSIONS

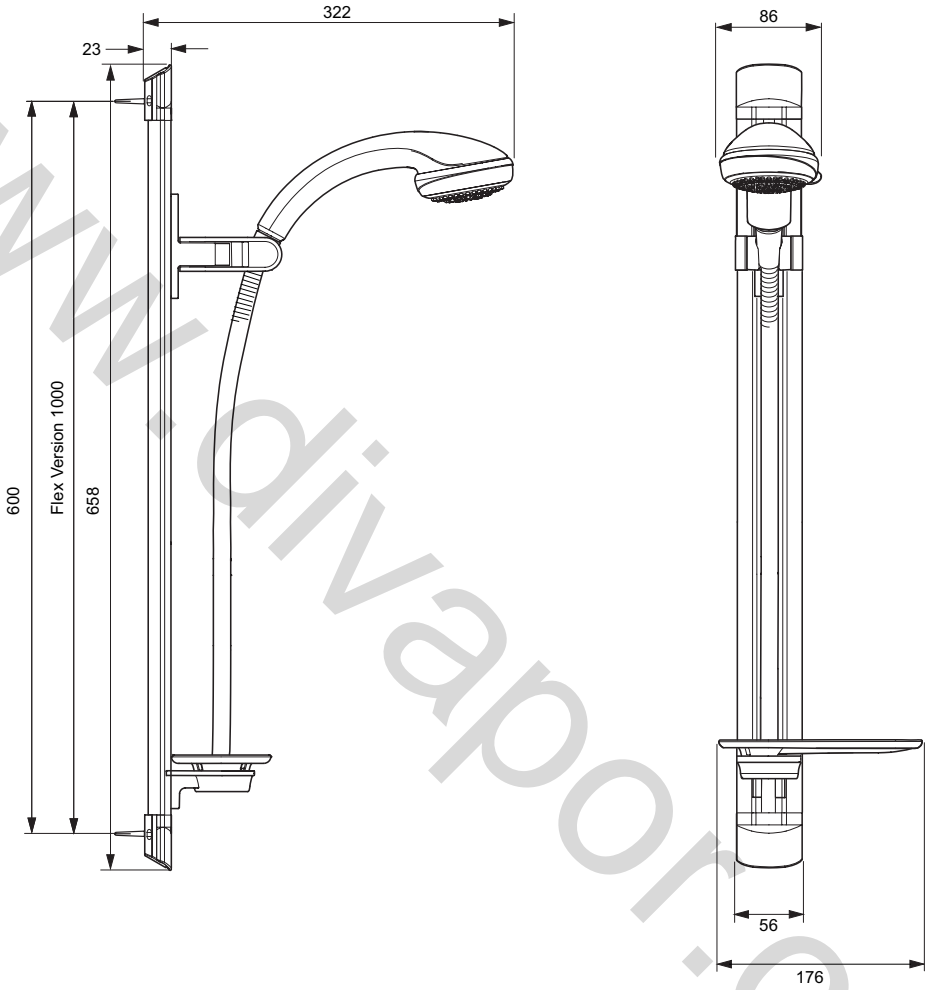

All dimensions in mm

# INSTALLATION

## General

Make sure that the shower fittings are installed by a competent installer.

Installations must comply with Water Regulations (Bye-Laws, Scotland), and any Local Regulations and Building Regulations in force at the time of installation.

Before installation carefully inspect the new fixture for any signs of damage.

The slide rail should be positioned to one side of the shower control at a convenient height for all the family. The slide rail can be fixed to a flat wall or into a corner.

**Note!** To prevent back siphonage and water supply contamination, the handset must either be prevented from dropping below the spill over level of the bath or shower or have an additional single check valve in the system. Single check valves may already be installed as part of the shower control

## Install the Shower Fittings Complete

### Wall Mounting

1. Decide on a suitable position for the slide rail avoiding buried cables and pipes. Make sure that when the hose retaining ring is placed on the lowest position on the slide rail there is a minimum of 25 mm between the handset and bath/tray spill-over level. This is necessary to prevent back-siphonage.

**Note!** Special consideration should be given to fixing arrangements when installing onto a dry lined, stud partition, shower cubicle or laminated panel wall structures. Installers may wish to obtain alternative proprietary cavity fixing, or choose other options, however, these methods of fixing are beyond the scope of this guide.

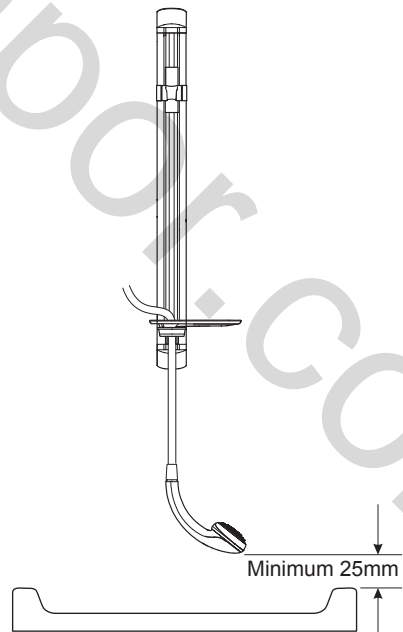

- Carefully remove the protective film from the slide rail.
- Holding the clamp bracket, squeeze the sides together and push the clamp bracket onto the slide rail.

**Note!** It is important that you slide the shorter edge of the clamp bracket onto the slide rail.

- Slide the hose retaining ring onto the slide rail.
- Push the slide rail supports onto each end of the slide rail assembly.

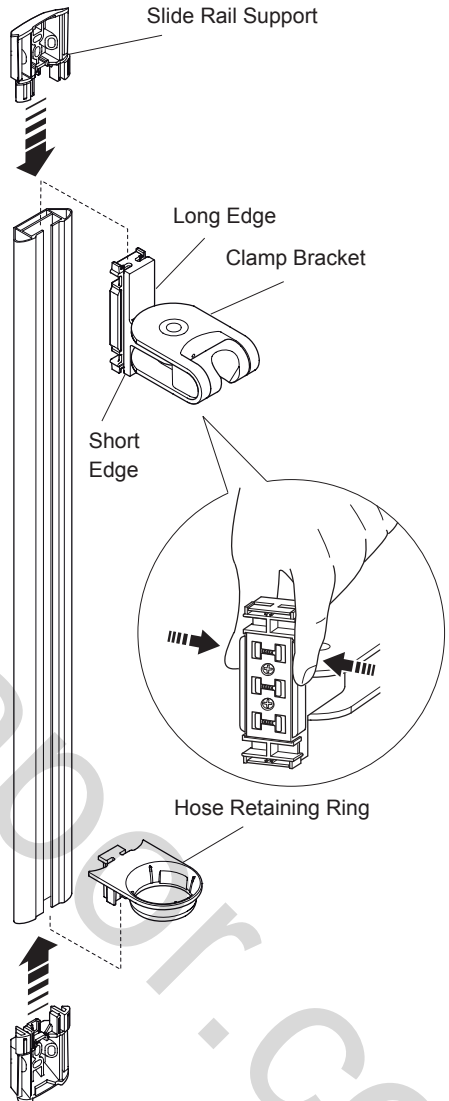

6. Hold the slide rail assembly against the wall in the desired position.

**Note!** If fixing the slide rail into a corner see "**Corner Mounting**"

7. Use the slide rail supports as a template and mark the positions of the top and bottom fixing holes.

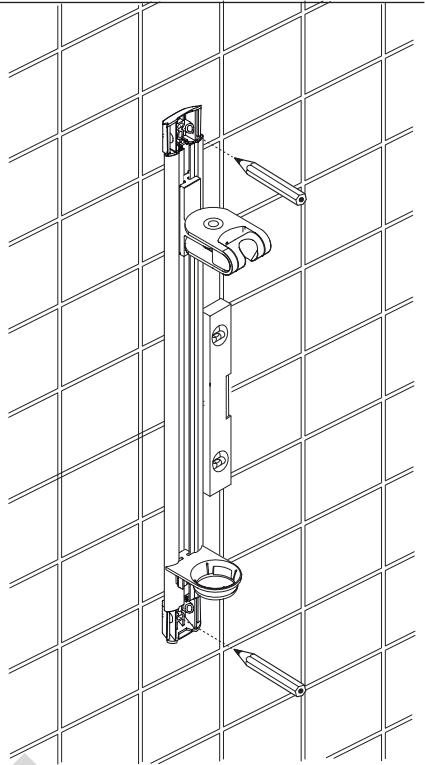

**Note!** When marking the position of the holes, if using the vertical oval hole on the top of the slide rail, then use the horizontal oval hole on the bottom fixing. This will allow you to make slight vertical and horizontal adjustments to the slide rail.

8. Check that the slide rail is vertical before drilling fixing holes.

**Caution!** Make sure that you avoid buried pipes and cables when you drill the wall.

9. Drill two 8.0 mm fixing holes, one at the top of the slide rail and one at the bottom of the slide rail.

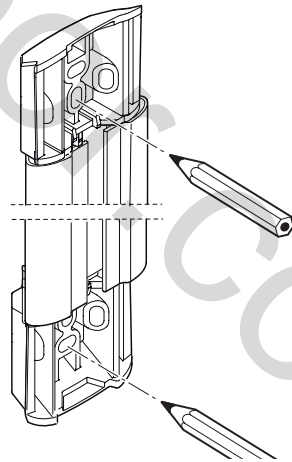



10. Fit the wall plugs.

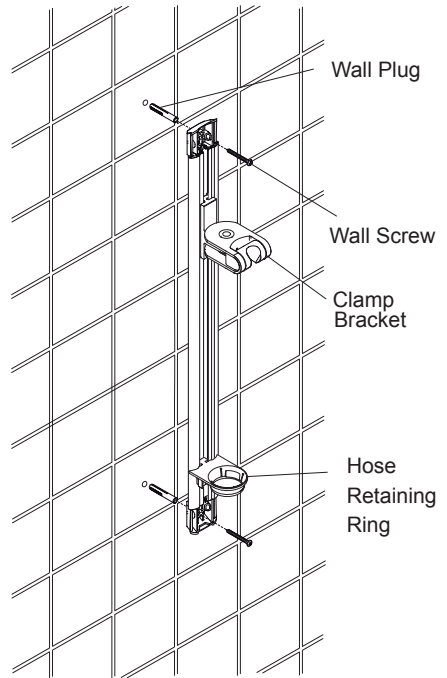

11. Hold the slide rail against the wall and gently screw the slide rail into position. Check that the slide rail is vertical and make any adjustments before fully tightening the wall screws.

Slide Rail Support Cover

12. Push on the slide rail support covers.

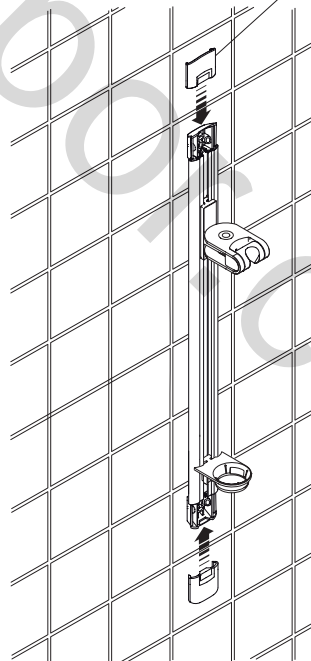

13. Align the notch on the soap dish with the recess on the hose retaining ring.

14. Push the soap dish onto the hose retaining ring.

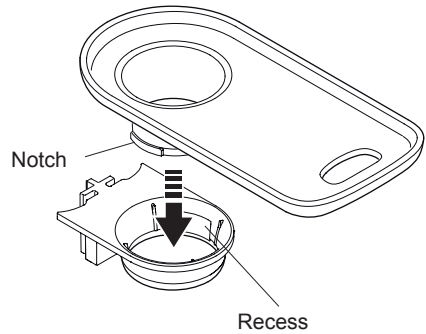

15. To lock the soap dish into position twist the soap dish to the right or if preferred twist to the left.

**Note!** If space is limited, you do not have to fit the soap dish to the hose retaining ring, but the hose retaining ring must be fitted.

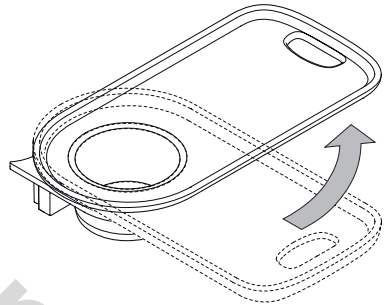

16. Attach the hose onto the handset. Make sure that the hose washer is fitted and **do not overtighten**.

17. If required, use the additional hose washer supplied for the handset

18. Pass the hose through the hose retaining ring and soap dish (if fitted).

19. Attach the hose to the outlet of the shower control. Make sure that the hose washer is fitted.

20. Place the handset into the clamp bracket.

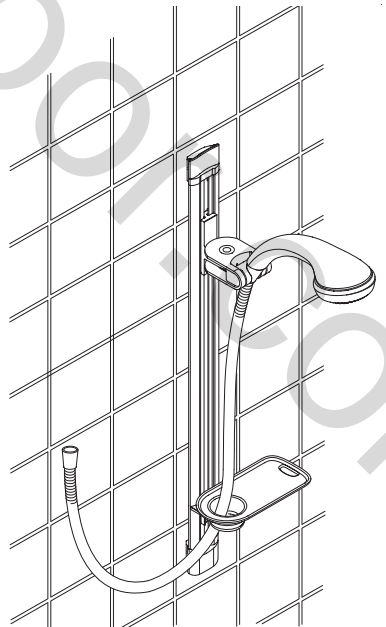

## Corner Mounting

1. For corner mounting first follow the Wall Mounting Instructions steps 1 to 6.
2. Hold the slide rail assembly against the wall in the desired position.
3. Use the slide rail supports as a template and mark the position of the two top fixing holes and the two bottom fixing holes.

**Note!** Check that the slide rail supports are sitting on both walls before drilling fixing holes.

4. Drill two 8mm fixing holes at the top of the slide rail and two at the bottom of the slide rail.

**Caution!** Make sure that you avoid buried pipes and cables when you drill the wall.

5. Fit the wall plugs.
6. Hold the slide rail against the wall and gently screw the slide rail into position. Check that the slide rail is vertical and make any adjustments before fully tightening the fixing screws.
7. Push on the slide rail support covers.
8. To complete the installation follow Wall Mounting Instructions steps 13 to 19.

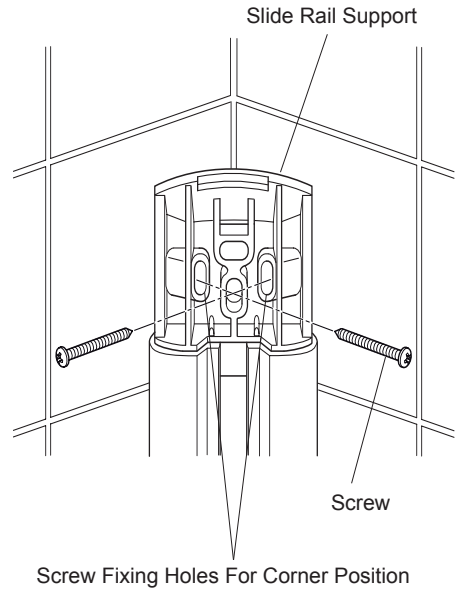

# OPERATION

## Adjustable Handset Operation

The handset has four different spray modes, **Eco**, **Start**, **Soothe** and **Force**. The handset has a combined checkvalve and flow regulator fitted in the handset. The handset operation is described below:

1. **Eco:** Water flows from the outer set of holes at a reduced flow rate to save water. To select the Eco setting, turn the spray plate fully clockwise.

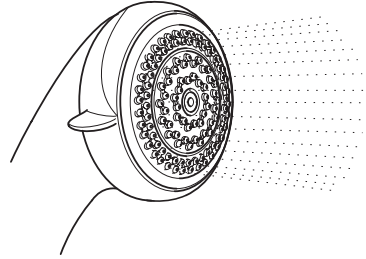

2. **Start:** Turn the spray plate anticlockwise until it 'clicks'. Water will flow from the outer set of holes.

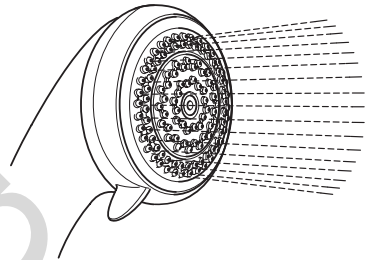

3. **Soothe:** Turn the spray plate anticlockwise until it 'clicks'. Water will flow from the large diameter holes.

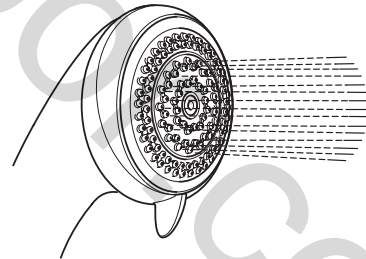

4. **Force:** Turn the spray plate anticlockwise until it 'clicks'. Water will flow from the inner set of holes.

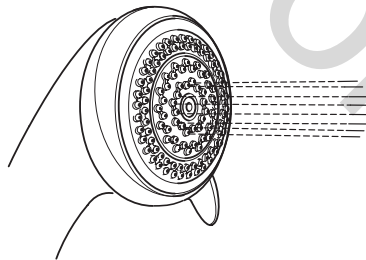

# MAINTENANCE

## Cleaning

Many household cleaners contain abrasives and chemical substances, and should not be used for cleaning plated or plastic fittings. These finishes should be cleaned with a mild washing up detergent or soap solution, and then wiped dry using a soft cloth.

1. To remove limescale, use your thumb or a soft cloth to wipe any limescale from the soft rubber nozzles and the front face of the showerhead.

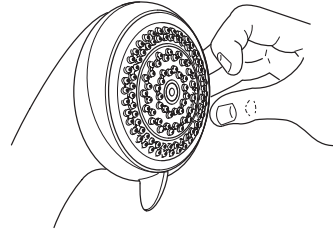

## Spray Plate Assembly - Internal

1. Remove the spray plate assembly. Refer to "**Spray plate assembly - removal and installation**".
2. Remove the inner and outer nozzle ring retainers.
3. Clean all the components with a stiff brush. If necessary use a plastic kettle descalent in accordance with the manufacturer's instructions. Flush thoroughly with water before the shower is used.
4. If necessary replace the 'O' seals. Refer to **Spare Parts**.
5. Refit the components in reverse order. Make sure the 'O' seals, and the inner/outer nozzle ring retainers are fitted correctly. Refer to "**Spray plate assembly - removal and installation**".

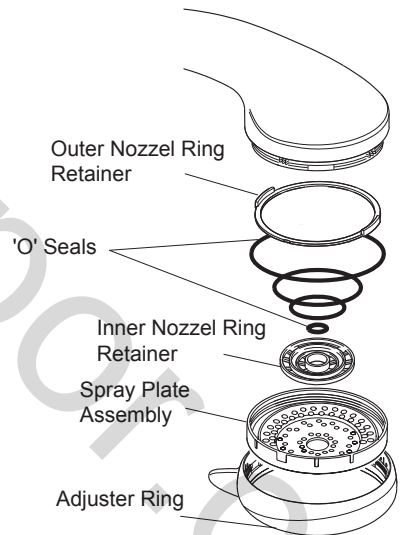

## Spray Plate Assembly-Removal

1. Turn the adjuster ring fully anticlockwise.
2. Unclip and remove the adjuster ring.
3. Unscrew the spray plate assembly in an anticlockwise direction. The 'O' seals will provide some resistance.
4. Remove the inner and outer nozzle retaining rings.

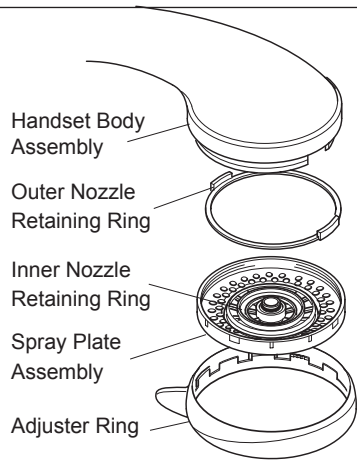

## Nozzle Ring Removal

1. Carry out instructions 1 to 4 of "**Spray Plate Removal**".
2. Remove both the inner and outer low capacity nozzle rings.
3. Carry out instructions 1 to 6 of "**Spray Plate Installation**".

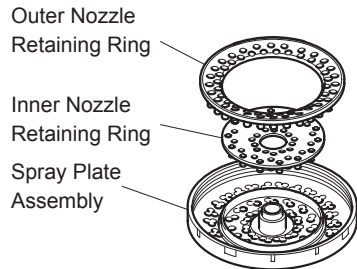

## Spray Plate Installation

1. Make sure that the four 'O' seals are all correctly fitted.
2. Fit inner nozzle ring retainer on to the spray plate assembly and fit the outer nozzle ring retainer on to the flow divertor.
3. Turn the flow divertor fully clockwise.
4. Carefully screw the spray plate assembly onto the flow divertor.
5. Align the inner teeth on the adjuster ring with the teeth on the handset flow divertor. Clip the adjuster ring into position.

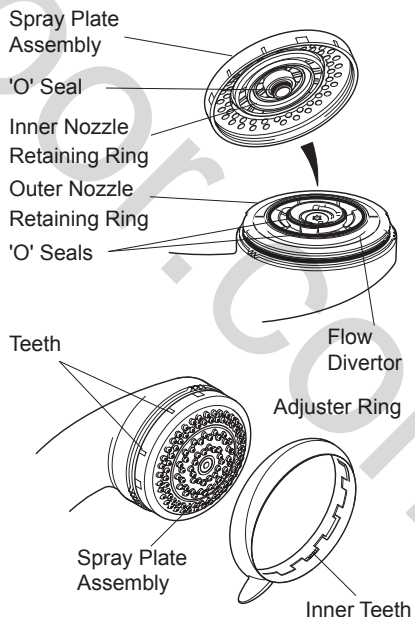

## FAULT DIAGNOSIS

The trouble shooting information tabled below gives details on what you can do as a user, should you encounter difficulties with the shower fittings whilst operating the shower. Before replacing any parts make sure that the underlying cause of the malfunction has been resolved.

Malfunction	Cause	Remedy
No flow or low flow rate from the shower fitting.	<p>The spray plate assembly is blocked.</p> <p>The hose is blocked or twisted.</p> <p>Problem with the shower control.</p>	<p>Refer to the '<b>Cleaning</b>' section.</p> <p>Clear blockage or replace the hose.</p> <p>Refer to the Appliance Installation and User Guide.</p>
Water dripping from the handset spray plate.	<p>A small amount of water may be retained in the shower handset after the shower control has been turned off. This may drain over a few minutes.</p> <p>Defective shower control.</p>	<p>This is quite normal. Adjusting the position of the shower handset may reduce the draining time.</p> <p>Refer to the Appliance Installation and User Guide.</p>
The shower temperature changes when the spray setting is adjusted.	The spray plate assembly is blocked.	<p>Make sure that the spray plate assembly is clean. Refer to the '<b>Cleaning</b>' section. If the malfunction persists refer to the Appliance Installation and User Guide.</p>
Hose does not fit into the clamp bracket securely.	Clamp bracket fitted upside down in the slide rail.	Remove the clamp bracket and rotate 180° and refit.

# SPARES

450.08	Service Pack 'O' Seals - components identified 'A'
632.73	Hose Washer
1603.098	Handset (White)
1603.102	Slide Rail Supports ( x 2 )
1603.103	Soap Dish and Hose Retaining Ring
1603.104	Chrome Hose - 1.25m
1603.106	Chrome Hose - 2m (Flex Product)
1603.112	Mounting Pack
1603.113	Slide Rail 06 Satin
1603.114	Slide Rail 10 Satin
1603.115	Adjuster Ring - White
1603.116	Spray Plate Assembly
1603.131	Adjuster Ring (Grey)
1603.132	Flex Clamp Bracket
1603.128	Handset - (Grey Adjuster Ring)
1644.124	Clamp Bracket



# Mira Advance Shower Fittings Spare Parts Diagram

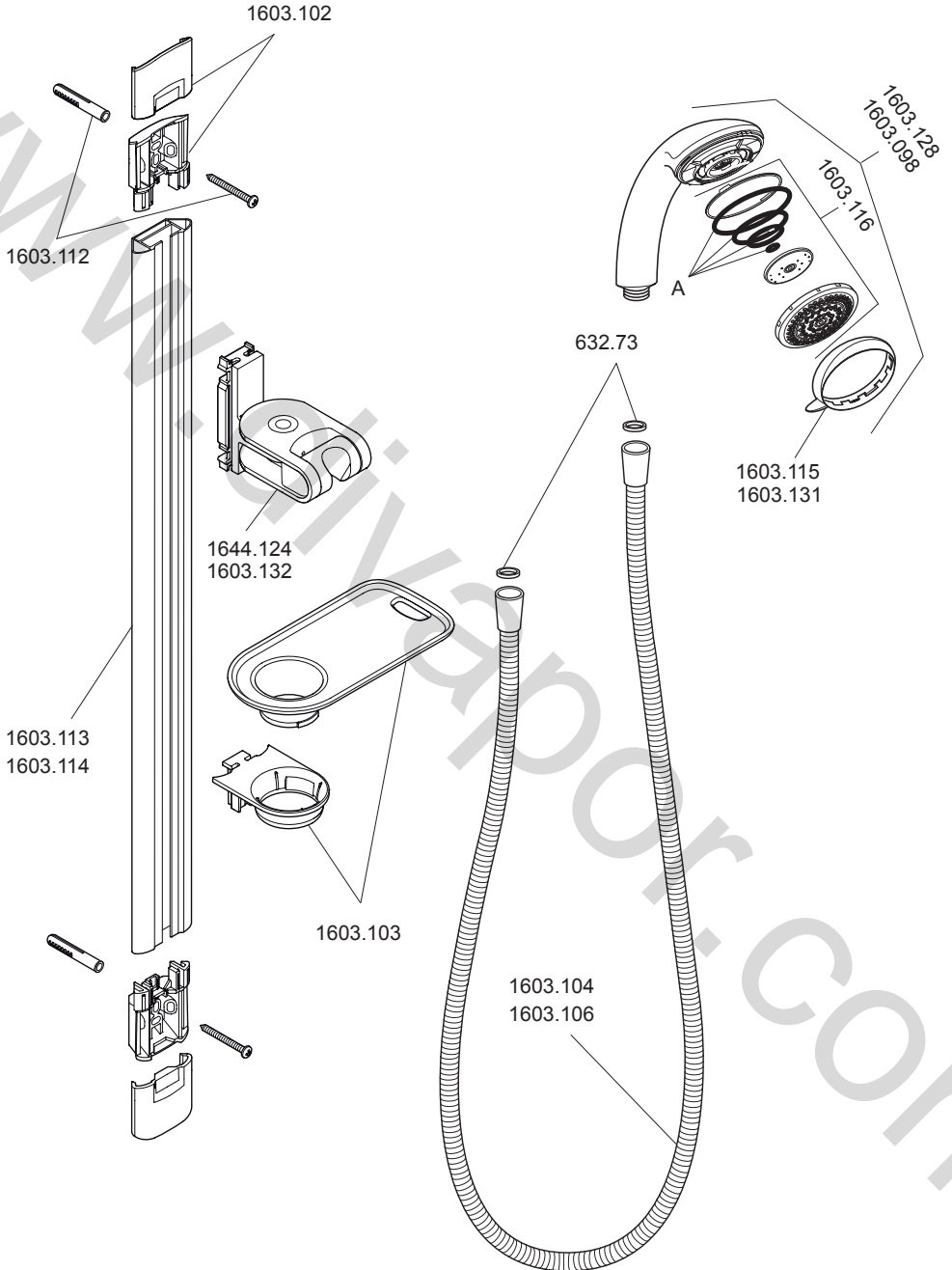

# NOTES

www.divapor.com

www.divapor.com

## CUSTOMER SERVICE

### Guarantee

Your product has the benefit of our manufacturer's guarantee which starts from the date of purchase.

To activate this guarantee, please return your completed registration card, visit our website or free phone 0800 0731248 within 30 days of purchase (UK only).

Within the guarantee period we will resolve defects in materials or workmanship, free of charge, by repairing or replacing parts or product as we may choose.

**This guarantee is in addition to your statutory rights and is subject to the following conditions:**

- The guarantee applies solely to the original installation under normal use and to the original purchaser only. The product must be installed and maintained in accordance with the instructions given in this user guide.
- Servicing must only be undertaken by us or our appointed representative. **Note!** if a service visit is required the product must be fully installed and connected to services.
- Repair under this guarantee does not extend the original expiry date. The guarantee on any replacement parts or product ends at the original expiry date.
- For shower fittings or consumable items we reserve the right to supply replacement parts only.

**The guarantee does not cover:**

- Call out charges for non product faults (such as damage or performance issues arising from incorrect installation, improper use, inappropriate cleaning, lack of maintenance, build up of limescale, frost damage, corrosion, system debris or blocked filters) or where no fault has been found with the product.
- Water or electrical supply, waste and isolation issues.
- Compensation for loss of use of the product or consequential loss of any kind.
- Damage or defects caused if the product is repaired or modified by persons not authorised by us or our appointed representative.
- Routine maintenance or replacement parts to comply with the requirements of the TMV 2 or TMV 3 healthcare schemes.
- Accidental or wilful damage.
- Products purchased ex-showroom display.

### What to do if something goes wrong

If your product does not work correctly refer to this manual for fault diagnosis and check that it is installed and commissioned in accordance with our instructions.

If this does not resolve the issue, contact us for help and advice.

### Extended Guarantees

A selection of protection plans are available that enable you to cover repair bills (excludes Eire). Ring 01922 471763 for more details.



**Helpdesk Service** - Ring our Customer Services Team for product advice, to purchase spare parts or accessories or to set up service visit. You can contact us via phone or e-mail, details below. Please provide your model name, power rating (if applicable) and date of purchase.



**Mira Showers Website ([www.mirashowers.co.uk](http://www.mirashowers.co.uk))**

Visit our website to register your guarantee, download user guides, diagnose faults, purchase our full range of accessories and popular spares, or request a service visit.



**Spares and Accessories** - We hold the largest stocks of genuine Mira spares and accessories. Contact us for a price or visit our website to purchase items from our accessory range and popular spares.



**Service/Repairs** - No one knows our products better than our nationwide team of Service Technicians. We can carry out service or repair work to your product both during and after the guarantee period. Ask about our fixed price service repairs.

### To Contact Us: UK



**0844 571 5000**



**Fax: 01242 282595**



E-mail: Visit [www.mirashowers.co.uk/contactus](http://www.mirashowers.co.uk/contactus)



Mira Customer Services Dept, Cromwell Road, Cheltenham, Gloucestershire, GL52 5EP

### To Contact Us: Eire Only



**01 531 9337**



E-mail: [CustomerServiceEire@mirashowers.com](mailto:CustomerServiceEire@mirashowers.com)

Mira is a registered trade mark of Kohler Mira Limited.

The company reserves the right to alter product specifications without notice.



FM 14648

**mira**  
SHOWERS