

# ***mira***

## Element

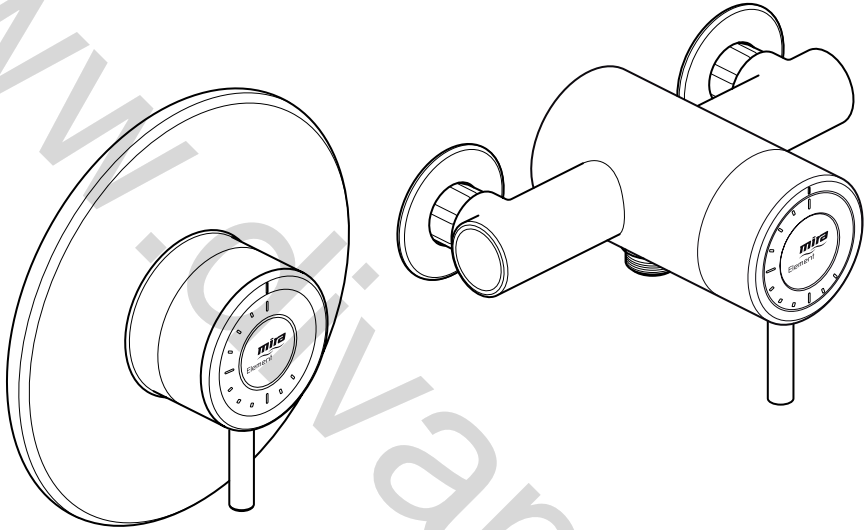

MIRA ELEMENT

THERMOSTATIC MIXER

INSTALLATION AND USER GUIDE

**These instructions must be left with the user.**

## CONTENTS

<b>Introduction</b>	<b>2</b>
Guarantee	3
Recommended Usage	3
Patents and Design Registration	3
<b>Safety : Warnings</b>	<b>3</b>
<b>Pack Contents</b>	<b>4</b>
Exposed Thermostatic Mixer	4
Built-in Thermostatic Mixer	4
<b>Specifications</b>	<b>5</b>
Pressures	5
Temperatures	5
Thermostatic Shut-down	5
Connections	5
Flow Rates	5
Dimensions	6
<b>Installation</b>	<b>7</b>
Suitable Plumbing Systems	7
General	7
Exposed Thermostatic Mixer	8
Built-in Thermostatic Mixer	10
Solid Wall or Stud Partition Fixing using Rear Mountings	10
Panel Fixing using Securing Brackets	12
Solid Wall or Stud Partition Fixing using Securing Brackets	13
RAC Assembly	14
Control Assembly (Built-in Models)	16
<b>Reversed Inlet Supplies</b>	<b>17</b>
<b>Operation</b>	<b>18</b>
<b>Commissioning</b>	<b>18</b>
Maximum Temperature Setting	18
<b>User Maintenance</b>	<b>19</b>
Fault Diagnosis	19
<b>Maintenance</b>	<b>19</b>
<b>Spare Parts</b>	<b>21</b>
Exposed Thermostatic Mixer	21
Built-in Thermostatic Mixer	22
RAC Assembly	23

## INTRODUCTION

Thank you for purchasing a quality Mira product. To enjoy the full potential of your new product, please take time to read this guide thoroughly, having done so, keep it handy for future reference.

The Mira Element thermostatic mixer is a thermostatic shower control with a single control lever for on/off and temperature control.

There is no adjustable flow control. A 12 L/Min flow regulator is supplied for high pressure systems to reduce excessive shower force.

The thermostatic mixer incorporates a wax capsule temperature sensing unit, which provides an almost immediate response to changes in pressures or temperature of the incoming water supplies to maintain the selected temperature. An adjustable maximum temperature stop is provided which limits the temperature to a safe level. Inlet filters are fitted to protect the thermostatic cartridge.

**Mira Element Exposed:** Thermostatic Mixer for connection to rising, falling or rear entry pipework, supplied with L14D EV shower fittings.

**Mira Element Built-in:** Thermostatic Mixer for connection to concealed pipework, supplied with L14D BIV shower fittings or BIR showerhead arm and deluge head.

### Type 2 Valves

This product has been certified as a Type 2 valve under the BUILD CERT TMV2 scheme. This product also complies with the Water Supply (water fittings) Regulations 1999.

### Application

The approved designations for Type 2 Valves are as follows:

Models	Designation
Mira Element	HP-S, LP-S

Important! The fitting of any flow regulator will invalidate TMV2 compliance due to the minimum flow rate requirements. Do not fit flow regulators in TMV2 applications

For Type 2 Valves refer to the TMV2 Requirements Manual.

## Guarantee

For **domestic installations**, Mira Showers guarantee the Mira Element against any defect in materials or workmanship for a period of **five** years from the date of purchase (shower fittings for one year).

For **non-domestic installations**, Mira Showers guarantee the Mira Element against any defect in materials or workmanship for a period of **one** year from the date of purchase.

For terms and conditions refer to the back cover of this guide.

## Recommended Usage

Application	Valve with Fittings
Domestic	✓
Light Commercial	✓
Heavy Commercial	✗
Healthcare	✗

## Patents and Design Registration

### Patents:

GB: 2 291 693, 2 392 225, 2 421 297,  
2 422 886

Euro: 1 672 257 DE FR GB IT NL SE

USA: 7 240 850

### Patent Applications:

GB: 0621637.8, 2 456 271

Euro: 03254070.0, 07015846.4

USA: 2006-0124758-A1, 2007-0221740-A1

World: WD 2008/053207

### Design Registration:

000555768-0006, 000555768-0007

## SAFETY : WARNINGS

Mira thermostatic mixers are precision engineered and should give continued safe and controlled performance, provided:

1. They are installed, commissioned, operated and maintained in accordance with manufacturer's recommendations.
2. Type 2 Valves are only used for applications covered by their approved designations, refer to the TMV2 Requirements Manual.
3. Periodic attention is given, when necessary, to maintain the product in good functional order.

### Caution!

1. Read all of these instructions.
2. Retain this guide for later use.
3. Pass on this guide in the event of change of ownership of the installation site.
4. Follow all warnings, cautions and instructions contained in this guide.
5. Anyone who may have difficulty understanding or operating the controls of any shower should be attended whilst showering. Particular consideration should be given to the young, the elderly, the infirm or anyone inexperienced in the correct operation of the controls.
6. Rapid/Excessive movement of the flow and/or temperature control levers may result in momentary unstable blend temperatures.
7. Care is required when adjusting flow or temperature, make sure that the temperature has stabilised.
8. When this product has reached the end of its serviceable life, it should be disposed of in a safe manner, in accordance with current local authority recycling, or waste disposal policy.

If you experience any difficulty with the installation or operation of your new thermostatic mixer, please refer to '**Fault Diagnosis**', before contacting Mira Showers. Our contact details can be found on the back cover of this guide.

# PACK CONTENTS

Tick the appropriate boxes to familiarise yourself with the part names and to confirm that all of the parts are included.

## Exposed Thermostatic Mixer

- 1 x Thermostatic Mixing Valve

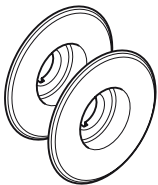
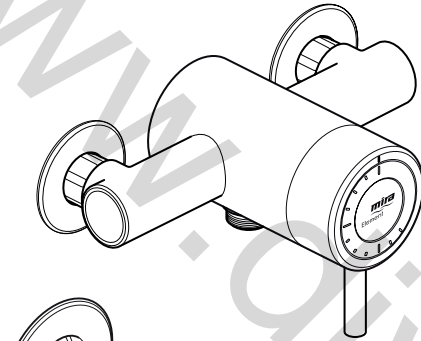

- 2 x Concealing Plates

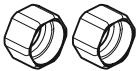

- 2 x Compression Nuts



- 2 x Olives



- 2 x Wall Plugs



- 2 x Fixing Screws



- 1 x 2.5 mm Hexagonal Key



- 1 x Flow Regulator

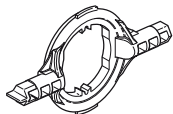

- 1 x 'O' Key

### Documentation

- 1 x Guarantee Registration Document
- 1 x Installation Template
- 1 x TMV2 Requirements Manual

## Built-in Thermostatic Mixer

- 1 x Thermostatic Mixing Valve (attached to the building-in shroud)

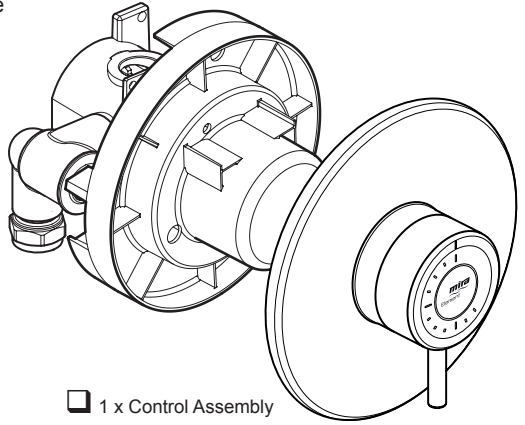

- 1 x Control Assembly

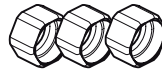

- 3 x Compression Nuts



- 3 x Olives



- 2 x Wall Plugs



- 2 x Fixing Screws



- 1 x 2.5 mm Hexagonal Key

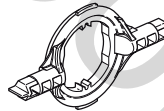

- 1 x 'O' Key



- 1 x Flow Regulator

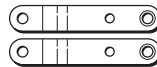

- 2 x Securing Brackets



- 2 x Bracket Securing Screws



- 2 x M5 x 40 mm Securing Screws

Not Illustrated

- 1 x RAC Assembly (BIV models only)

### Documentation

- 1 x Guarantee Registration Document
- 1 x TMV2 Requirements Manual

## SPECIFICATIONS

For Type 2 Valves, the supply conditions specified in the TMV2 Requirements Manual take precedence over the operating parameters which follow.

### Pressures

- Max Static Pressure: **10 Bar**.
- Max Maintained Pressure: **5 Bar**.
- Min Maintained Pressure (Gravity System): **0.1 Bar** (0.1 bar = 1 Metre head from cold tank base to showerhead outlet).

**Note!** For gravity fed or other low pressure systems (0.5 bar or below) do not fit the outlet flow regulator.

- For optimum performance supplies should be nominally equal.

### Flow Regulator Installation

Flow regulators are supplied with this product and should be fitted in high pressure systems to either;

- Reduce excessive force and flow rate.
- Reduce noise through the mixer due to high or unequal pressures.
- Stabilise incoming supply temperatures.

Important! The fitting of flow regulators will invalidate any TMV2 compliance due to minimum flow rate requirements. Do not fit the flow regulator in TMV2 applications.

### Temperatures

- Factory Pre-set (Blend) Shower: **41°C**.
- Optimum Thermostatic Control Range: **35°C to 43°C** (achieved with supplies of 15°C cold, 65°C hot and nominally equal pressures).
- Recommended Hot Supply: **60°C to 65°C**  
**Note!** The mixing valve can operate at higher temperatures for short periods without damage, however this could detrimentally affect thermostatic performance. For safety and performance reasons it is recommended that the maximum hot water temperature is limited to 65°C.
- Cold Water Range: up to **25°C**.
- Minimum Recommended Differential between Hot Supply and Outlet Temperature: **12°C**.

### Thermostatic Shut-down

- For safety and comfort the thermostat will shut off the mixing valve **within 2 Seconds** if either supply fails (achieved only if the blend temperature has a minimum differential of 12°C from either supply temperature).

### Connections

- Inlets: 15 mm Compression.
- Outlet: ½" BSP Flat Face / 15 mm Compression
- Standard connections are: **hot - left, cold - right, outlet - bottom (EV models), top (BIV and BIR models)**.

### Flow Rates

Typical flow rates on high pressure systems (1 to 5 Bar) with 12 L/Min flow regulator fitted - Mira Element with L14D Shower Fittings

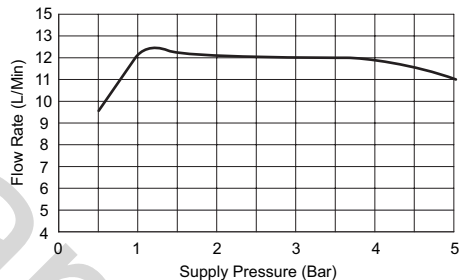

Typical flow rates on low pressure systems (0.1 to 1 Bar) Mira Element with L14D Shower Fittings

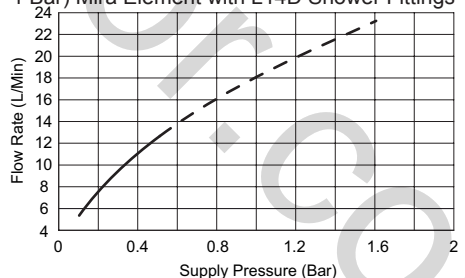

## Dimensions

### Exposed Thermostatic Mixer

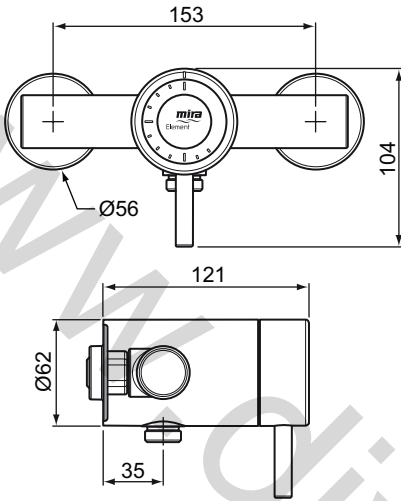

### Built-in Thermostatic Mixer

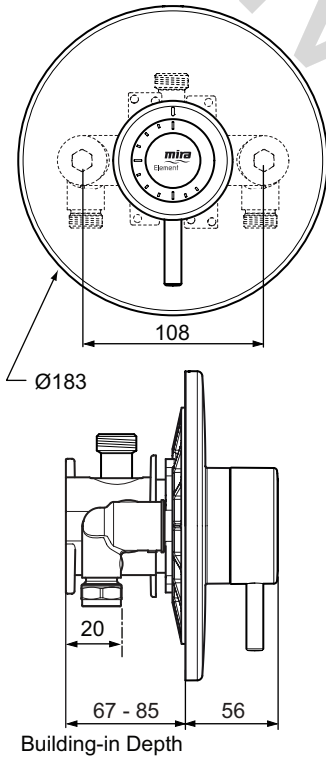

All dimensions in mm

# INSTALLATION

## Suitable Plumbing Systems

### Gravity Fed:

The thermostatic mixer must be fed from a cold water cistern (usually fitted in the loft space) and a hot water cylinder (usually fitted in the airing cupboard) providing nominally equal pressures.

### Mains Pressurised Instantaneous Hot Water System (Combination Boiler):

The thermostatic mixer can be installed with systems of this type with balanced pressures. (Recommended Minimum Maintained Pressure: **1.0 Bar**).

### Unvented Mains Pressure System:

The thermostatic mixer can be installed with an unvented, stored hot water system.

### Pumped System:

The thermostatic mixer can be installed with an inlet pump (twin impeller). The pump must be installed in a suitable location and in accordance with its instructions.

## General

Installation must be carried out in accordance with these instructions, and must be conducted by designated, qualified and competent personnel. The installation must comply with the "Water Supply Regulations 1999 (Water Fittings)" or any particular regulations and practices, specified by the local water company or water undertakers.

**Note!** Make sure that all site requirements correspond to the information given in section: '**Specifications**'. For Type 2 Valves, the supply conditions specified in the TMV2 Requirements Manual take precedence over the operating parameters which follow.

1. The Mixer must not be installed in an area where it may freeze.
2. For stud partitions alternative fixings may be required.
3. Isolating valves **must** be installed close to the Mixer for ease of maintenance.
4. Pipework must be rigidly supported and avoid any strain on the connections.

5. Pipework dead-legs should be kept to a minimum.
6. Decide on a suitable position for the Mixer. The position of the Mixer and the Shower Fittings must provide a minimum gap of 25 mm between the spill-over level of the shower tray/bath and the showerhead (refer to illustration). This is to prevent back-siphonage. For further information on the installation of your **Shower Fittings**, refer to the Fittings Installation and User Guide.  
**Note!** Only use Shower Fittings recommended by the manufacturer or supplier.

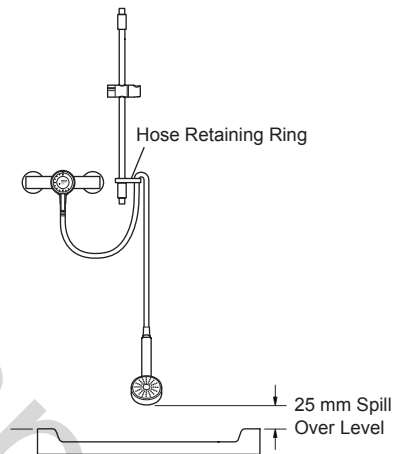

# Exposed Thermostatic Mixer

## Installing the Thermostatic Mixer

1. The thermostatic mixer can be installed with rear, rising or falling supply inlets. Decide on the most appropriate method for your installation, and if necessary, loosen the grub screws and rotate the inlet elbows to suit.

**Important!** Make sure that the elbows are pushed fully onto the mixer before tightening the grub screws, **do not** overtighten.

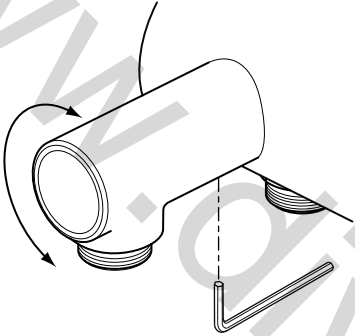

2. Use the installation template to mark the positions of the holes for the backplate and the pipe centres.

For rising or falling supplies the pipe positions should be set 35 mm from the centre of pipe to the finished wall at 153 mm centres.

**Note!** Allow a minimum of 150 mm either side of the mixer to allow servicing of the hot and cold inlet filters.

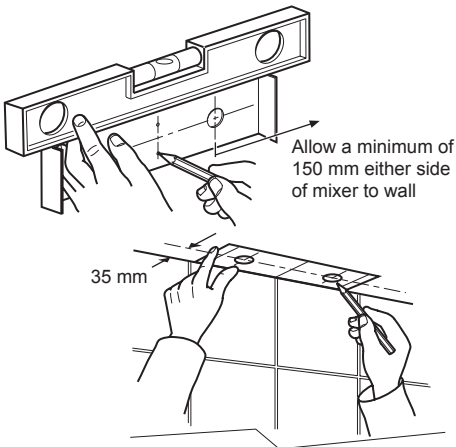

3. For solid walls drill the holes for the backplate

with a 6 mm drill and insert the wall plugs.

**Note!** For other types of wall structure alternative fixings may be required (not supplied).

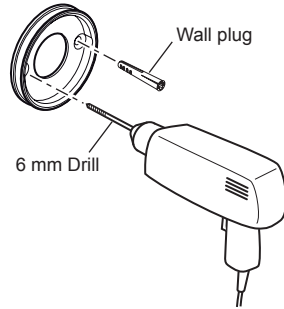

### 4. For Rear Entry Supplies Only:

- a) Drill the holes for the supply pipes at 153 mm centres.
- b) Recess the inlet holes  $\text{Ø}32 \text{ mm} \times 10 \text{ mm}$  deep to allow for the concealing plates.

**Note!** Depth must be sufficient to prevent the concealing plates fouling on the plumbing elbows.

5. Fit the supply pipework: **Hot - Left, Cold - Right.** For rear entry supplies the inlet pipework should extend 18 mm from the finished wall surface, for rising or falling supplies the centre of the pipe should be set 35 mm from the finished wall surface.

**Note!** If it is not possible to install the mixer with this pipework configuration complete the installation then refer to section: '**Reversed Inlet Supplies**'.

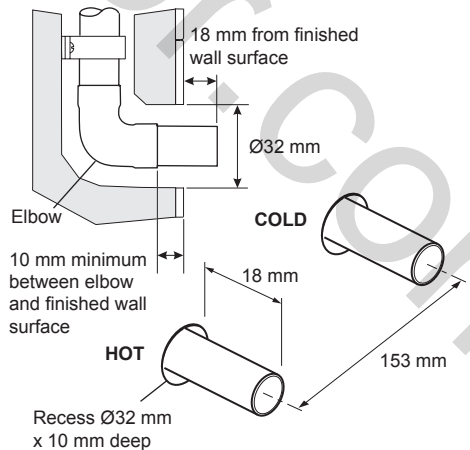



6. Remove the backplate from the mixer by loosening the grubscrew with a 2.5 mm hexagonal key.
7. Secure the backplate to the wall using the screws.

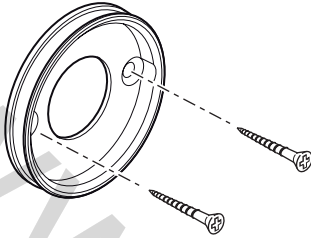

**8. For Rear Entry Supplies Only:**

- a) Fit the concealing plates over the inlet pipes.

**Note!** Apply silicone sealant to the back face of the flange.

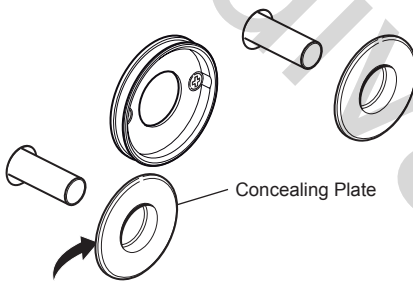

Apply Silicone Sealant

9. **Caution! It is essential at this point that the supply pipework is thoroughly flushed through before connection to the mixer.** Failure to do so may result in product malfunction and will not be covered under the guarantee.

10. Fit the compression nuts and olives onto the pipework.
11. Align the mixer with the pipework and fit onto the backplate.
12. Tighten the compression nuts onto the mixer with a suitable spanner.

**Caution!** Take care not to damage the chrome surfaces.

13. Tighten the grub screw to secure the mixer to the backplate.
14. Fit the shower fittings, refer to your shower fittings installation and user guide for instructions.

**Note!** For high pressure systems, a 12 litre/minute Flow Regulator (supplied) can be fitted under the Hose Washer (refer to illustration).

**Important!** The fitting of this flow regulator will invalidate any TMV2 compliance due to the minimum flow rate requirements. Do not fit the flow regulator in TMV2 applications.

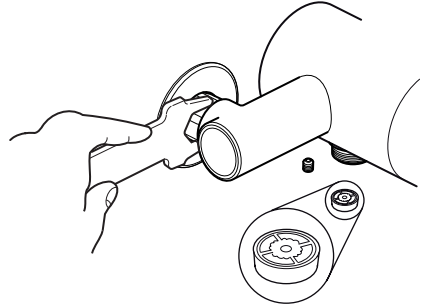

15. Turn on the hot and cold water supplies and check for leaks.

16. Before using the shower, refer to section: 'Commissioning'.

## Built-in Thermostatic Mixer

### Solid Wall or Stud Partition Fixing using Rear Mountings

1. Determine the route for the hot and cold supply pipework and for the outlet pipework. When connecting to the BIV Shower Fittings it is recommended that the outlet be positioned above and to one side of the mixer. This is to prevent the flexible hose from obstructing the shower controls.
2. Remove the two shroud screws (retain for later use) and remove the building-in shroud from the mixer.
3. Determine the position of the mixer and draw around the building-in shroud. A flat section on the shroud is provided for spirit level use.

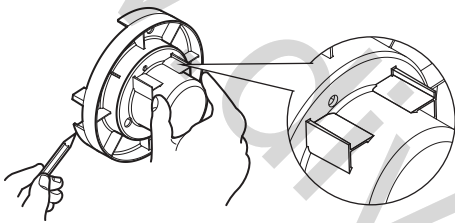

Mark the routes for the supply pipework at 108 mm centres (**Hot - Left, Cold - Right**).

**Falling Supplies:** For falling supplies use the 2.5 mm hexagonal key (supplied) to loosen the grubscrew in each elbow.

**Note!** It is important to retract the grubscrews sufficiently to clear the 'O' seals and the inlet flange to avoid causing damage to the seals.

5. Remove the elbows and install on opposite sides. Make sure that the elbows are pushed fully onto the inlet stubs then retighten the grubscrews using the 2.5 mm hexagonal key.

**Caution!** Do not overtighten.

**Note!** Make sure that the 'O' seals are correctly fitted and that the filter plugs are positioned to the front (i.e. hexagonal key facing forward).

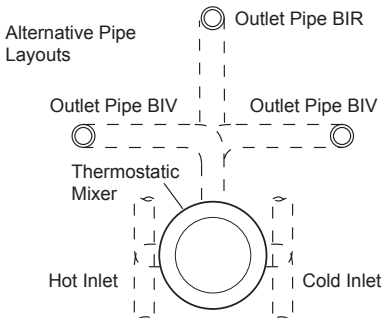

6. Cut away the plasterboard and/or brick work to the required depth.

**Important!** This depth 'X' will depend on the finished wall thickness e.g. tiles or facia board. Refer to the table for this measurement.

For stud partitions depth 'X' refers to the distance from the rear mounting e.g. timber noggin, to the front of the wall (before tiling).

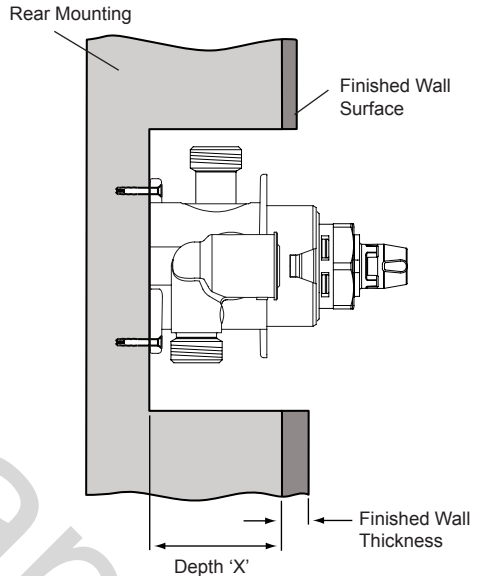

Finished Wall Thickness (e.g. tile and adhesive)	Wall Cutout Depth 'X'
4 mm	81 - 63 mm
6 mm	79 - 61 mm
8 mm	77 - 59 mm
10 mm	75 - 57 mm
12 mm	73 - 55 mm
14 mm	71 - 55 mm
16 mm	69 - 55 mm
18 mm	67 - 55 mm
20 mm	65 - 55 mm
22 mm	63 - 55 mm
24 mm	61 - 55 mm

7. Make sure that the mixer is level and central in the hole, and square to the finished wall surface (or the control components will not fit correctly), then mark the positions of the fixing screw holes on the wall.
8. For solid walls drill two 6 mm holes for the wall plugs.
9. Fit the hot and cold supply pipes (**Hot - Left, Cold - Right**).
10. **Caution! It is essential at this point that the supply pipework is thoroughly flushed through before connection to the mixer.** Failure to do so may result in product malfunction and will not be covered under the guarantee.
11. Insert the wall plugs (supplied) and attach the mixer to the wall with the screws provided.  
**Note!** For stud partition installations alternative fixings may be required (not supplied) to fix the mixer to the rear face of the wall cavity or to a timber noggin.
12. Make sure that the olives are fitted and connect the hot and cold supply pipes and tighten the compression nuts.

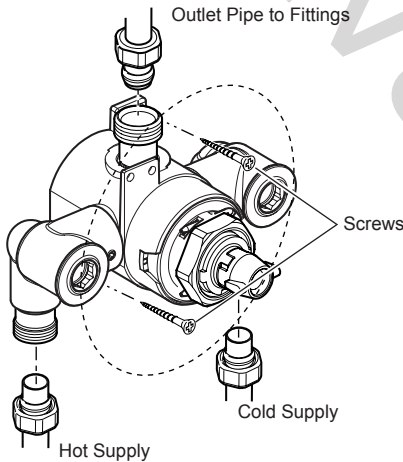

13. Connect the outlet pipework and install the RAC assembly or BIR assembly, **before** continuing with the installation of the mixing valve.

**RAC assembly**, go to section: 'Installation, RAC Assembly'.

**BIR assembly**, refer to your shower fittings installation and user guide then continue with instruction 14.

14. Turn on the water supplies and check for leaks.
15. Refit the building-in shroud to the mixer using the two shroud screws removed earlier.
16. Using the 'Finished Wall Indicator' on the building-in shroud as a guide, finish the wall, e.g. tiles.  
**Caution!** Make sure that the finished wall is within the maximum and minimum limits and to an even depth (no greater than 2 mm variation) or the control components will not fit correctly.

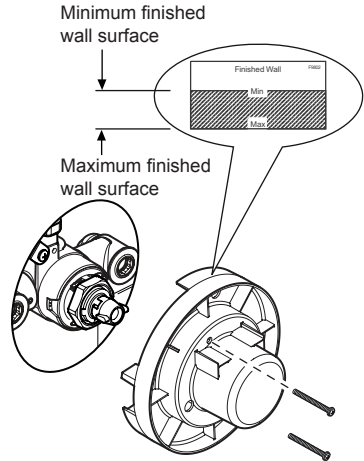

17. Remove the two shroud screws (retain for later use) and remove the building-in shroud.
18. Fit the concealing plate and control assembly, refer to section: 'Control Assembly'.

## Panel Fixing using Securing Brackets

**Note!** For laminated panels the mixer must be positioned from the rear of the panel.

Panel thickness must be between 4 and 12 mm (if a thicker panel is used, it will be necessary to recess the securing brackets into the rear of the panel).

**Important!** Make sure that there is a minimum clearance of 64 mm behind the laminated panel to house the mixer.

1. Refer to section: **'Solid Wall or Stud Partition Fixing using Rear Mountings'** and follow instructions 1 to 4.
2. Carefully cut out the laminated panel.
3. Fit the securing brackets to the mixer.

**Important!** The securing brackets must be fixed vertically, as illustrated.

**Important!** Make sure that the correct holes are used, otherwise the backplate cannot be fitted.

4. Position the mixer on the front of the panel, make sure that it is level and central in the hole, then mark the position of the M5 fixing holes.

**Important!** Make sure that the correct holes are used (refer to illustration).

**Note!** Make sure that the Filter Plugs are positioned so that they can be removed for servicing.

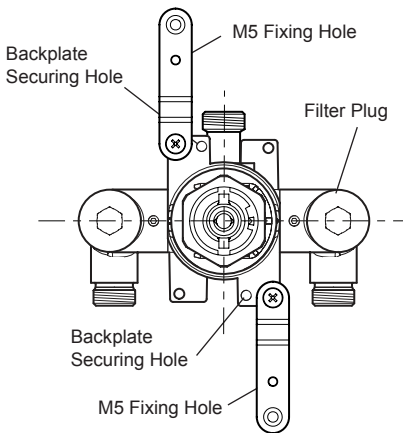

5. Drill the two 5.5 mm holes for the fixing positions (countersink the holes at the front).
6. Fit the hot and cold supply pipes (**Hot - Left, Cold - Right**).

7. **Caution! It is essential at this point that the supply pipework is thoroughly flushed through before connection to the mixer.** Failure to do so may result in product malfunction and will not be covered under the guarantee.

8. Secure the mixer with the M5 x 40 mm screws as shown.

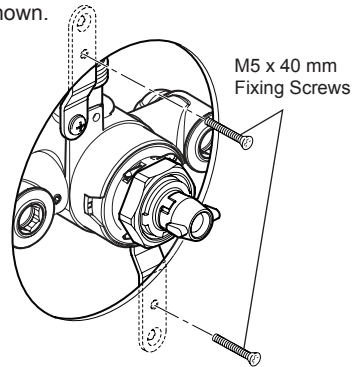

9. Make sure that the olives are fitted, connect the hot and cold supply pipes and tighten the compression nuts.

10. Connect the outlet pipework and install the RAC assembly or BIR assembly, **before** continuing with the installation of the mixing valve.

**RAC assembly**, go to section: **'Installation, RAC Assembly'**.

**BIR assembly**, refer to your shower fittings installation and user guide then continue with instruction.

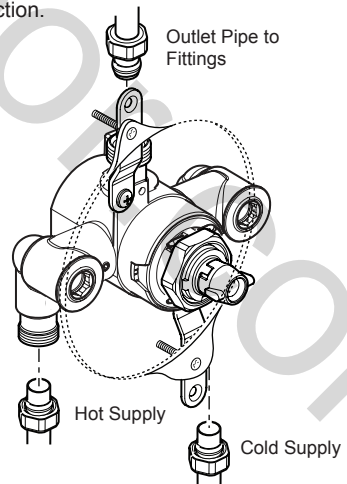

11. Turn on the water supplies and check for leaks.
12. Fit the concealing plate and control assembly, refer to section: **'Control Assembly'**.

## Solid Wall or Stud Partition Fixing using Securing Brackets

1. Refer to section: 'Solid Wall or Stud Partition Fixing using Rear Mountings' and follow instructions 1 to 4.
2. Remove the plasterboard and/or brick work to a minimum depth of 62 mm.

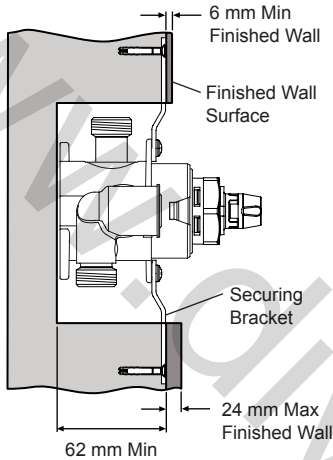

3. Fit the securing brackets to the mixer with the bracket securing screws.

**Important!** Make sure that the correct holes are used, otherwise the backplate cannot be fitted.

**Note!** The securing brackets can be rotated for suitable fixing points.

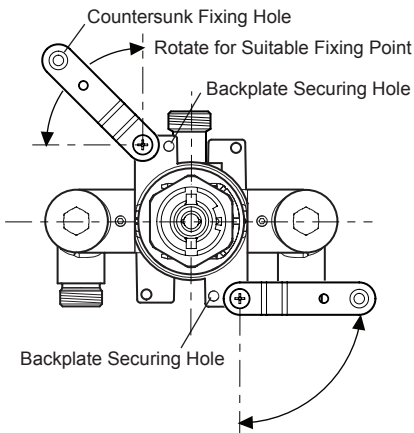

**Note!** Securing Brackets shown in preferred position to allow the Compression Nuts to be tightened.

4. Make sure that the mixer is level and mark the positions for the countersunk fixing holes on the wall.
5. For solid walls drill two 6 mm holes for the wall plugs.
  - Caution!** Do not drill into pipes in the wall.
6. Fit the hot and cold supply pipework (**Hot - Left, Cold - Right**).
7. **Caution! It is essential at this point that the supply pipework is thoroughly flushed through before connection to the mixer.** Failure to do so may result in product malfunction and will not be covered under the guarantee.
8. Insert the wall plugs (supplied) and attach the mixer to the wall with the screws provided.
  - Note!** For stud partition installations alternative fixings may be required (not supplied).
9. Make sure that the olives are fitted, connect the hot and cold supply pipes and tighten the compression nuts.
10. Connect the outlet pipework and install the RAC assembly or BIR assembly, **before** continuing with the installation of the mixing valve.
- RAC assembly**, go to section: 'Installation, RAC Assembly'.
- BIR assembly**, refer to your shower fittings installation and user guide then continue with instruction 11.
11. Turn on the water supplies and check for leaks.

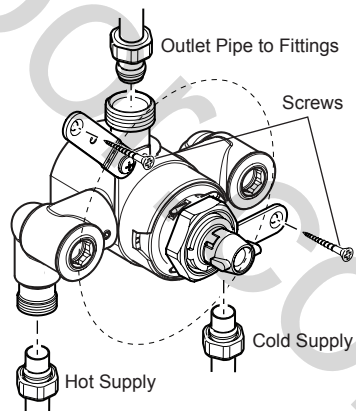

12. Turn on the water supplies and check for leaks.
13. Refit the building-in shroud to the mixer using the two shroud screws removed earlier.
14. Using the 'Finished Wall Indicator' on the building-in shroud as a guide, finish the wall, e.g. tiles.

**Caution!** Make sure that the finished wall is within the maximum and minimum limits and to an even depth (no greater than 2 mm variation) or the control components will not fit correctly.

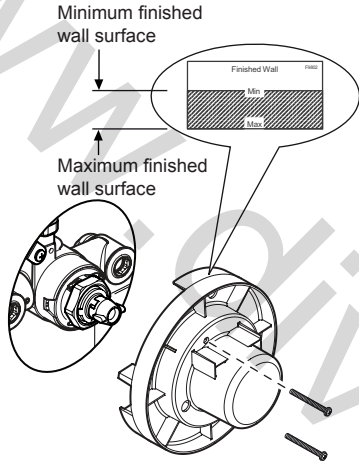

15. Remove the two shroud screws (retain for later use) and remove the building-in shroud.
16. Fit the concealing plate and control assembly, refer to section: '**Control Assembly**'.

## RAC Assembly

1. Before the RAC assembly can be fitted you must have first installed your built-in shower control and have connected the inlet and outlet pipework.

**Important!** Make sure that the outlet pipework protrudes through a  $\text{Ø}25$  mm hole in the wall or stud partition by at least 40 mm.

**Note!** For stud partition installations where access to the rear of the partition is possible, fit the RAC wall plate over the outlet pipework on the inside of the partition.

For stud partition installations where access to the rear of the wall is not possible, follow instructions for solid wall installations, making sure that suitable wall fixings (not supplied) are used to secure the wall plate to the outside of the stud partition.

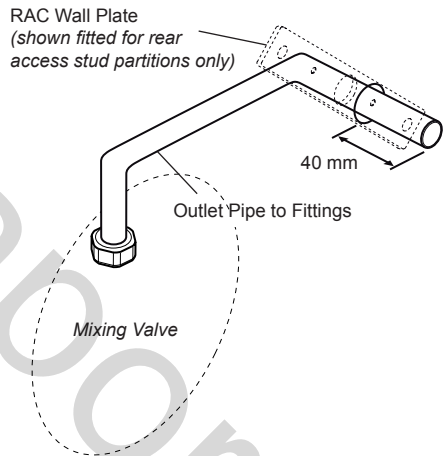

2. Temporarily cap off the outlet pipe, turn on the water supplies and check for leaks.
3. Determine the finished wall position (e.g. tile thickness). Turn off the water supply, carefully uncap the outlet pipe and cut to length, the outlet pipe must protrude through the **finished wall surface** by 21–23 mm.

**Note!** Remove any burrs from the pipes before proceeding.

4. For solid wall installations or stud partition installations **without** rear access go to instruction 9.

For stud partition installations with access to the rear of the partition continue with instruction 5.

5. Finish the wall, e.g. tiles.

6. Place the RAC backplate over the outlet pipe with the arrow pointing up. The screw holes should be at 45° to the horizontal.
7. Mark the positions of the two RAC backplate fixing holes and drill two Ø5.5 mm holes.  
**Caution!** Make sure that you do not drill into pipework in the wall.
8. Hold the RAC wall plate in position on the rear of the partition, insert the two backplate screws and secure the RAC backplate to the wall plate. Make sure that the foam seal abuts the finished wall surface. Go to instruction 18.

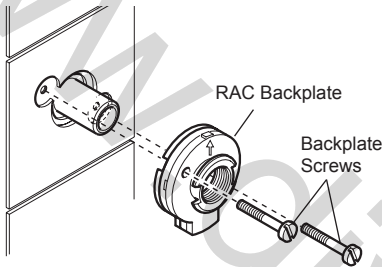

9. Loosely attach the RAC backplate to the RAC wall plate, using the two backplate screws provided.
10. Place the RAC backplate/wall plate assembly over the outlet pipe with the arrow pointing vertically up. The screw holes should be at 40° to the horizontal.
11. Mark the positions of the two RAC wall plate fixing holes.

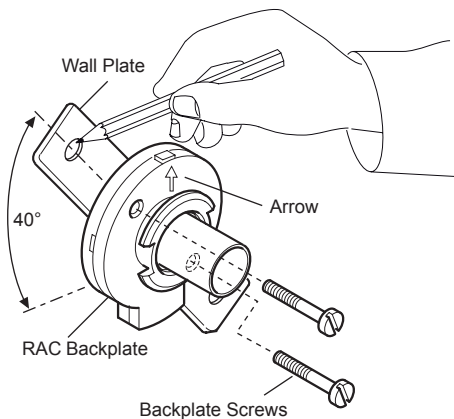

12. Remove the assembly from the wall and separate the backplate from the wall plate.

13. For solid walls drill two Ø6 mm holes for the wall plugs. For other types of wall structure alternative fixings may be required (not supplied). If necessary, make a recess 6 mm deep to accept the wall plate for flush fitting of the outlet to the wall surface.

**Caution!** Make sure that you do not drill into pipework in the wall.

14. Fit the two wall plugs supplied and secure the wall plate to the wall with the two wall plate screws.
15. Make sure that there is clearance behind the wall plate and temporarily fit the two backplate screws into the wall plate. This will prevent the fixing holes from becoming blocked with plaster or grout.
16. Finish the wall, e.g. tiles.

17. Place the backplate over the outlet pipe with the arrow pointing vertically up and tighten the two backplate screws. Make sure that the foam seal abuts the finished wall surface.

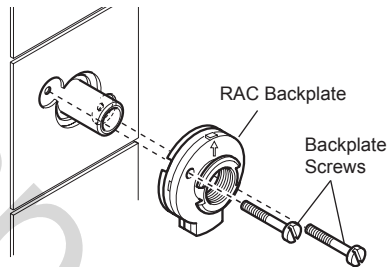

18. Check that the blue 'O' seal is fitted inside the backplate nut. Fit the olive and the backplate nut over the outlet pipe, do not tighten the nut fully at this point.

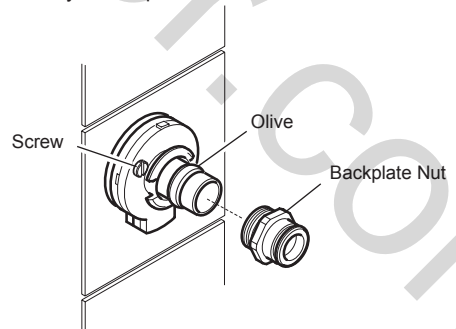

19. Check that the second 'O' seal (black) is fitted to the outside of the backplate nut. Press the elbow onto the backplate, make sure that the clips on the elbow engage with the backplate.

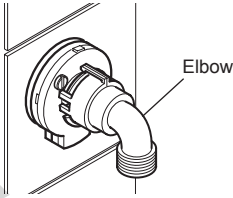

20. Press the shroud over the elbow, make sure that it engages with the lugs on the backplate.
21. This completes the installation of the RAC assembly.

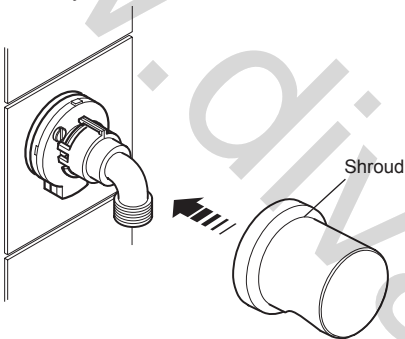

### Control Assembly (Built-in Models)

1. Unscrew and remove the control lever handle.
2. Loosen the grub screw (by approximately 4 turns) and pull off the control lever and bearing.
3. Carefully unclip the concealing plate from the backplate.

**Note!** Use a screwdriver in the cutout to assist separation.

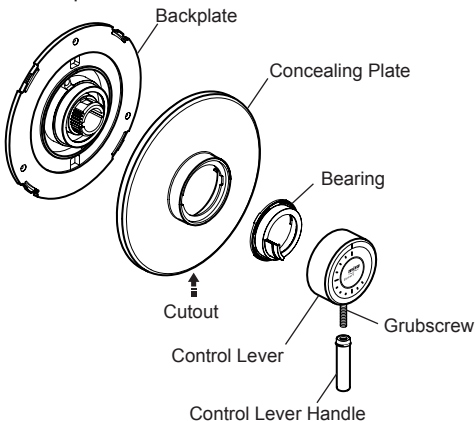

4. Align the slots in the backplate with the lugs on the hub, and attach the backplate to the mixer using the two shroud screws removed earlier. Tighten the screws until the foam seal is fully compressed. **Do not overtighten.**
5. With the cutout at the bottom, locate the concealing plate over the mixer, engage the crosses in the concealing plate with the square recesses in the backplate, and push firmly until the concealing plate clicks into position.

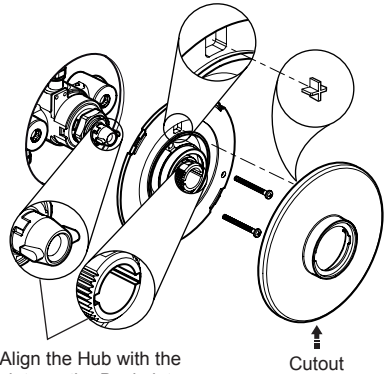

6. With the lug in the 8 o'clock position fit the bearing into the concealing plate.
7. Make sure that the hub is positioned fully clockwise and refit the control lever with the grub screw at the bottom, retighten the grub screw and refit the control lever handle.

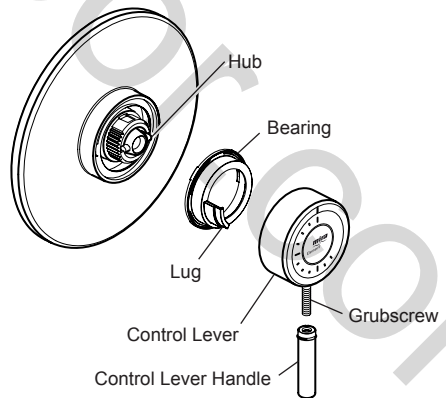

8. Before using the shower, refer to section: **'Commissioning'**.



## REVERSED INLET SUPPLIES

The Mira Element thermostatic mixer is supplied with inlet connections **Hot - Left, Cold - Right** as standard. If the hot and cold water supply pipes have been reversed during installation the thermostatic cartridge must be removed and rotated 180°.

1. Isolate the hot and cold water supplies and operate the control lever to relieve pressure and drain any residual water.
2. Unscrew and remove the control lever handle.
3. Loosen the grubscrew (by approximately 4 turns) and pull off the control lever and bearing.
4. **Built-in Models Only:**
  - 4.1 Carefully unclip the concealing plate from the backplate.  
**Note!** Use a screwdriver in the cutout to assist separation.
  - 4.2 Unscrew the two shroud screws and remove the backplate from the mixer.

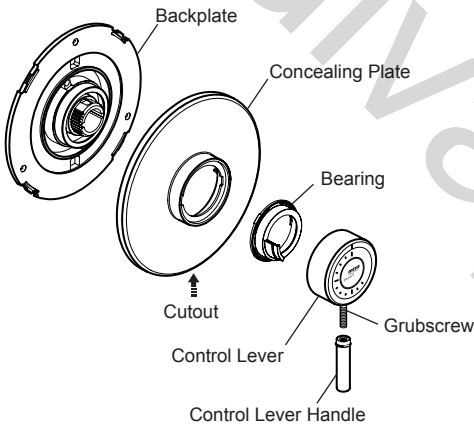

Built-in model shown

5. Fit the 'O' Key (supplied) onto the cartridge nut and turn anticlockwise. Unscrew fully and pull the cartridge from the mixer body.

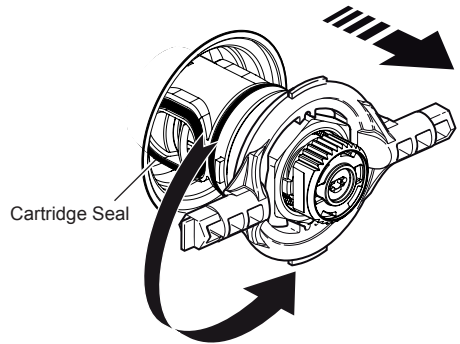

6. Rotate the Cartridge 180°.
7. Make sure that the two cartridge inlet seals are fitted and carefully push into the body, aligning the cartridge lugs into the body slots.  
**Note!** Check that the cartridge lug stamped 'H' is aligned with the hot inlet supply.  
**Important!** Take care when fitting the cartridge as damage to the cartridge inlet seals may result in dripping from the shower head.
8. Tighten the nut by turning the 'O' key clockwise.
9. **Built-in Models Only:** Refer to section: '**Control Assembly (Built-in Models)**' and follow instructions 4 to 9.
10. With the lug in the 8 o'clock position fit the bearing into the concealing plate (refer to illustration).
11. Make sure that the hub is positioned fully clockwise and refit the control lever with the grubscrew at the bottom, retighten the grubscrew and refit the control lever handle.
12. Before using the Shower, refer to section: '**Commissioning**'.

## OPERATION

The Mira Element thermostatic mixer is a thermostatic shower control with a single control lever for on/off and temperature control.

The Control Lever operates anti-clockwise in the following sequence:

- Off
- On
- Cold
- Warm
- Maximum Preset Temperature

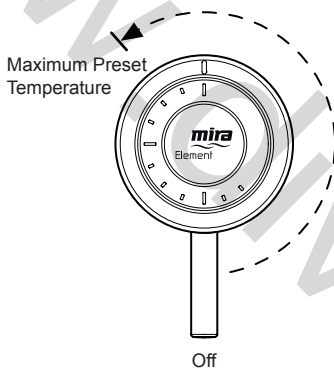

4. Turn on the shower to the maximum temperature by rotating the hub fully anticlockwise and allow the temperature to stabilise.
5. Unscrew the hub retaining screw with a 2.5 mm hexagon key.
6. Insert the 2.5 mm hexagon key into the centre of the spindle and engage with the recessed temperature adjusting screw.
7. Rotate the hexagon key until the required maximum temperature is obtained at the shower. Turn anticlockwise to increase the temperature, or clockwise to decrease the temperature ( $\frac{1}{4}$  turn = approximately  $1^{\circ}\text{C}$ ).

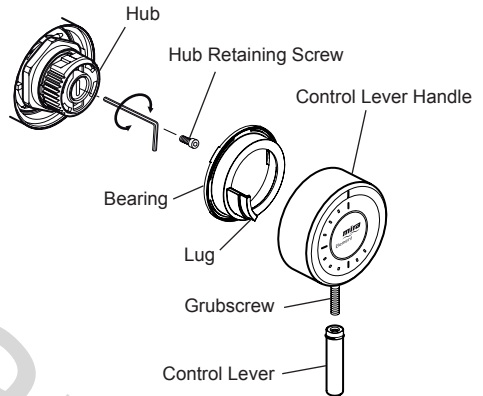

## COMMISSIONING

### Maximum Temperature Setting

Before using the shower the maximum temperature must be checked to make sure that it is at a safe level. It has been preset to approximately  $41^{\circ}\text{C}$  at the factory but due to variations in site conditions the maximum temperature may need adjustment.

**Note!** Make sure that the hot water temperature is at least  $55^{\circ}\text{C}$  and that there is sufficient supply.

For Type 2 installations the maximum blend temperature is determined by the application, refer to the TMV2 Requirements Manual.

1. Turn on the shower to the maximum temperature (i.e. fully anticlockwise) and allow the temperature to stabilise.

If the temperature is too hot or too cold, turn off the shower and adjust as follows:

2. Unscrew and remove the control lever handle.
3. Loosen the grubscrew (by approximately 4 turns) and pull off the control lever and bearing.

8. Once the desired maximum blend temperature has been achieved turn off the shower.
9. Refit the hub retaining screw.
10. With the lug in the 8 o'clock position refit the bearing.
11. Make sure that the hub is positioned fully clockwise and refit the control lever with the grubscrew at the bottom, retighten the grubscrew and refit the control lever handle.
12. Check that the showering temperature is correct.

## USER MAINTENANCE

If you require a Mira trained service engineer or agent, refer to section: '**Customer Services**'.

### Fault Diagnosis

#### Symptom:

- Only hot or cold water from the mixer outlet.
- Outlet temperature too hot / too cold.

#### Cause Rectification:

- Inlets reversed (hot supply to cold supply). Refer to section: '**Reversed Inlet Supplies**'.
- No hot or cold water reaching mixer.
- Check the filters for any blockage.
- Installation conditions outside operating parameters, refer to sections: '**Specifications**' and '**Commissioning**'.
- If the temperature is too cold and you have a combination type boiler it may not be producing sufficiently hot water at desired flow rate (refer to '**Specifications**'). Fit flow regulator (supplied) to shower valve outlet. For more information contact Mira Showers or visit the website.

#### Symptom:

- Fluctuating or reduced flow rate.

#### Cause Rectification:

- Check the showerhead, hose and filters for any blockage.
- Make sure that the maintained inlet pressures are nominally balanced and sufficient, refer to section: '**Specifications**'.
- Make sure that the inlet temperature differentials are sufficient, refer to section: '**Specifications**'.
- Air lock or partial blockage in the pipework.
- Flow regulator fitted incorrectly.

#### Symptom:

- Water leaking from showerhead.

#### Cause Rectification:

- Normal for a short period after shut off.
- Check that the pressures are not in excess of the specifications for the product.
- Renew the thermostatic cartridge.

## MAINTENANCE

### General

This Product is precision engineered and should give continued safe and controlled performance, provided:

1. It is installed, commissioned, operated and maintained in accordance with manufacturers recommendations.
2. Periodic attention is given, when necessary, to maintain the product in good functional order.

The Mira Element thermostatic mixer is designed to need only minimal maintenance in normal use. The only serviceable parts are the inlet filters which should be checked and cleaned every 12 months. If a malfunction occurs with the thermostatic cartridge then this will necessitate a complete cartridge replacement.

**Note!** The cartridge contains no internally serviceable parts.

If you require a Mira trained engineer or agent, refer to section: '**Customer Service**'.

### Lubricants

Silicone based lubricants must only be used on the rubber seals.

**Caution!** Oil based or other lubricant types may cause rapid deterioration of seals.

### Cleaning

The chrome plated parts should be cleaned using a mild washing up detergent or soap solution, rinsed and then wiped dry with a soft cloth.

**Warning!** Many household cleaners contain abrasive and chemical substances, and should not be used for cleaning plated or plastic fittings.

**Do not** use descalents on this product.

## Inlet Filters

The inlet filters should be checked and cleaned as necessary every 12 months.

**Note!** The inlet filters must not be removed except for cleaning. If the thermostatic mixer is operated without the inlet filters fitted the warranty on the product will be void.

### Exposed Models

1. Isolate the hot and cold water supplies and operate the control lever to drain any residual water.
2. Carefully remove the filter blanking caps and unscrew the filter caps with the 'O key' (supplied) or a 12 mm hexagonal wrench and remove the filters.

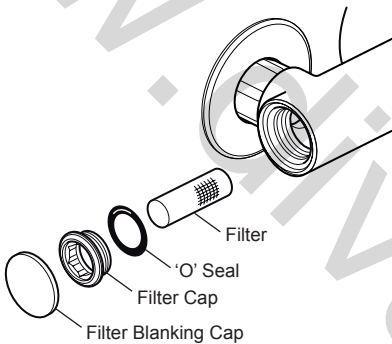

3. Clean the filters under a jet of water to remove any lodged particles.
4. Refit the filters and tighten the filter caps.  
**Note!** Make sure that the 'O' seal is fitted correctly and not damaged.
5. Turn on the hot and cold water supplies and check for leaks.
6. Refit the filter blanking caps.

### Built-in Models

**Note!** Refer to illustrations in section: 'Control Assembly (Built-in Models)'.

1. Isolate the hot and cold water supplies and operate the control lever to drain any residual water.
2. Unscrew the control lever handle, loosen the grub screw and pull off the control lever and bearing.
3. Carefully unclip the concealing plate from the backplate.  
**Note!** Use a screwdriver in the cutout to assist separation.

4. Unscrew the two shroud screws and remove the backplate from the mixer.
5. Unscrew the filter caps with the 'O key' (supplied) or a 12 mm hexagonal wrench and remove the filters.

**Note!** Use pliers to carefully remove the filters.

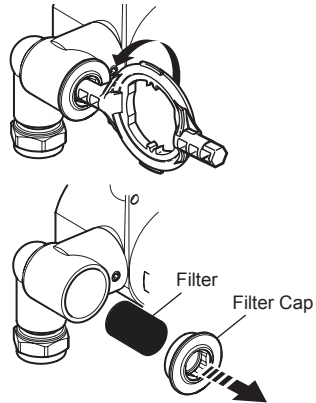

6. Clean each of the filters under a jet of water to remove any lodged particles.
7. Refit the filters and tighten the filter caps.  
**Note!** Make sure that the seal is fitted correctly and not damaged.
8. Turn on the hot and cold water supplies and check for leaks.
9. Refer to section: 'Control Assembly (Built-in Models)' and follow instructions 4 to 7.

# SPARE PARTS

## Exposed Thermostatic Mixer

- 1656.110 Seal Pack - Identified A
- 1656.116 Screw Pack - Identified B

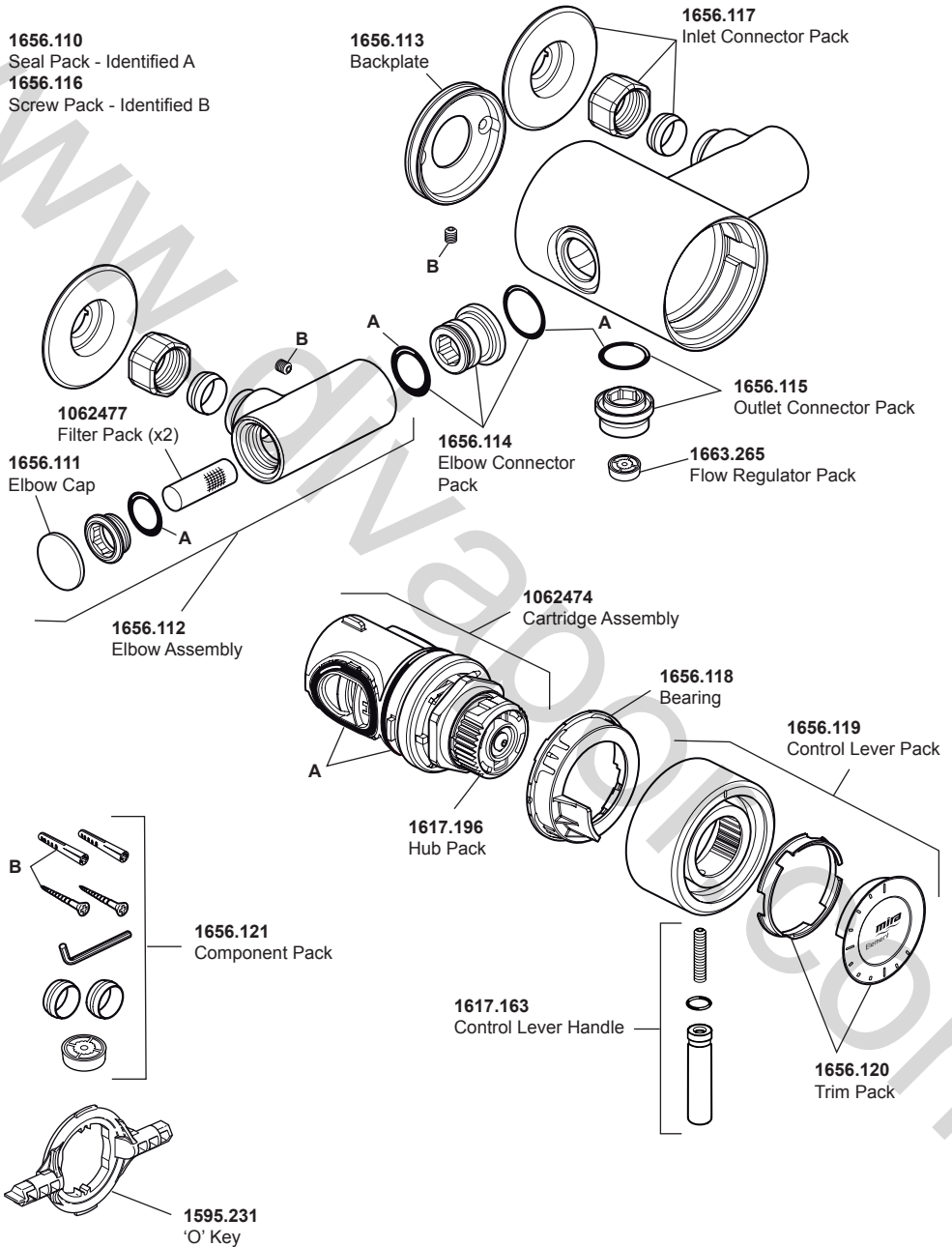

# Built-in Thermostatic Mixer

- 1595.067  
Screw Pack - Identified A
- 1651.138  
Seal Pack - Identified B

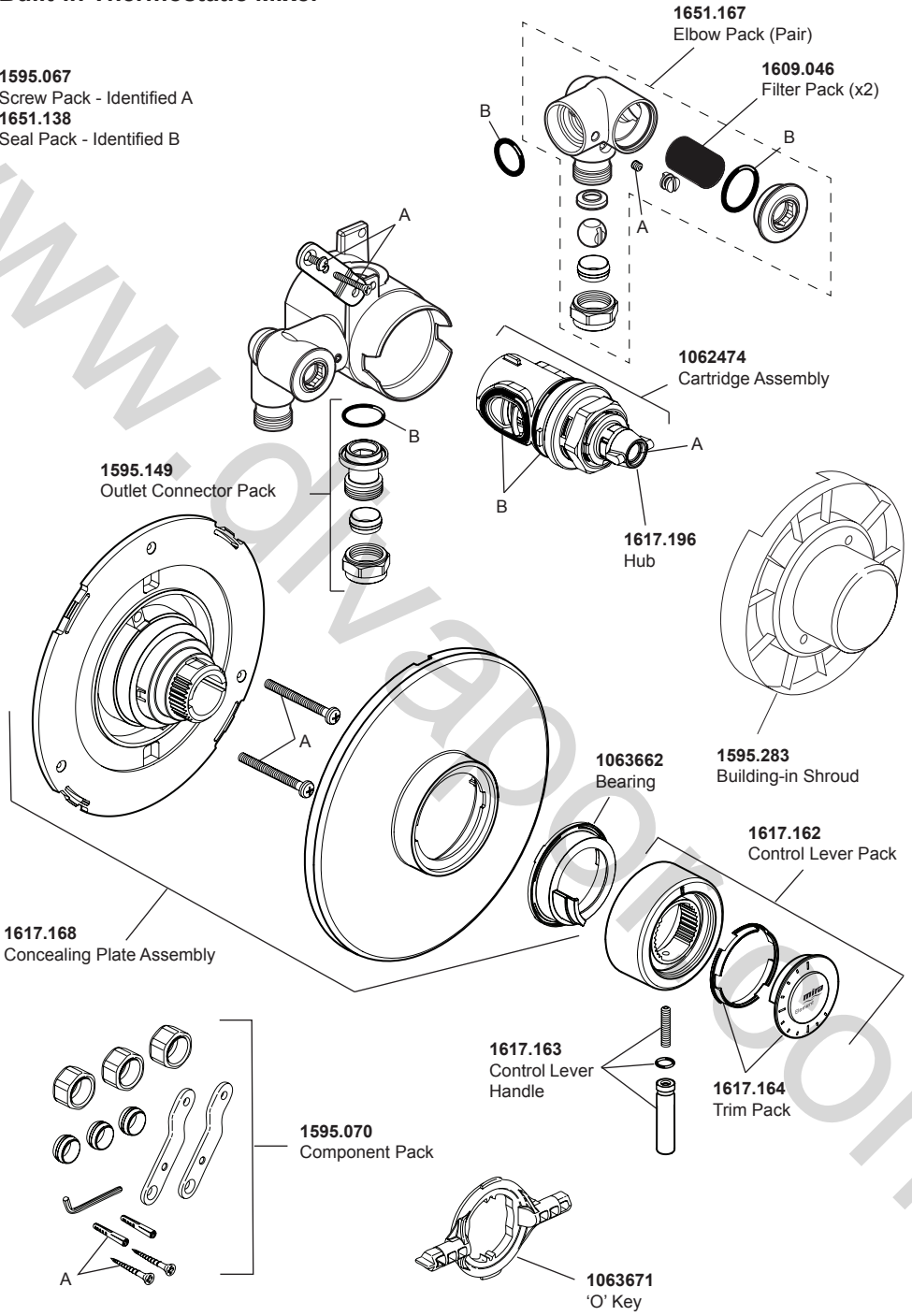

# RAC Assembly

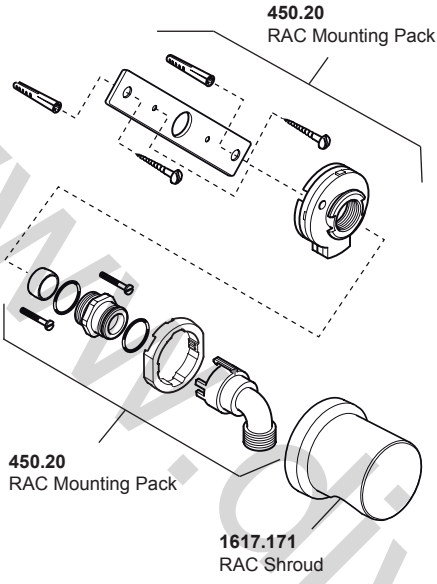

## CUSTOMER SERVICE

### Guarantee

Your product has the benefit of our manufacturer's guarantee which starts from the date of purchase.

To activate this guarantee, please return your completed registration card, visit our website or free phone 0800 0731248 within 30 days of purchase (UK only).

Within the guarantee period we will resolve defects in materials or workmanship, free of charge, by repairing or replacing parts or product as we may choose.

**This guarantee is in addition to your statutory rights and is subject to the following conditions:**

- The guarantee applies solely to the original installation under normal use and to the original purchaser only. The product must be installed and maintained in accordance with the instructions given in this user guide.
- Servicing must only be undertaken by us or our appointed representative. **Note!** if a service visit is required the product must be fully installed and connected to services.
- Repair under this guarantee does not extend the original expiry date. The guarantee on any replacement parts or product ends at the original expiry date.
- For shower fittings or consumable items we reserve the right to supply replacement parts only.

**The guarantee does not cover:**

- Call out charges for non product faults (such as damage or performance issues arising from incorrect installation, improper use, inappropriate cleaning, lack of maintenance, build up of limescale, frost damage, corrosion, system debris or blocked filters) or where no fault has been found with the product.
- Water or electrical supply, waste and isolation issues.
- Compensation for loss of use of the product or consequential loss of any kind.
- Damage or defects caused if the product is repaired or modified by persons not authorised by us or our appointed representative.
- Routine maintenance or replacement parts to comply with the requirements of the TMV 2 or TMV 3 healthcare schemes.
- Accidental or wilful damage.
- Products purchased ex-showroom display.

### What to do if something goes wrong

If your product does not work correctly refer to this manual for fault diagnosis and check that it is installed and commissioned in accordance with our instructions.

If this does not resolve the issue, contact us for help and advice.



**Helpdesk Service** - Ring our Customer Services Team for product advice, to purchase spare parts or accessories or to set up service visit. You can contact us via phone or e-mail, details below. Please provide your model name, power rating (if applicable) and date of purchase.



**Mira Showers Website ([www.mirashowers.co.uk](http://www.mirashowers.co.uk))**

Visit our website to register your guarantee, download user guides, diagnose faults, purchase our full range of accessories and popular spares, or request a service visit.



**Spares and Accessories** - We hold the largest stocks of genuine Mira spares and accessories. Contact us for a price or visit our website to purchase items from our accessory range and popular spares.



**Service/Repairs** - No one knows our products better than our nationwide team of Service Technicians. We can carry out service or repair work to your product both during and after the guarantee period. Ask about our fixed price service repairs.

### To Contact Us: UK



**0844 571 5000**



**Fax: 01242 282595**



E-mail: Visit [www.mirashowers.co.uk/contactus](http://www.mirashowers.co.uk/contactus)



Mira Customer Services Dept, Cromwell Road, Cheltenham, Gloucestershire, GL52 5EP

### To Contact Us: Eire Only



**01 531 9337**



E-mail: [CustomerServiceEire@mirashowers.com](mailto:CustomerServiceEire@mirashowers.com)

Mira is a registered trade mark of Kohler Mira Limited.

The company reserves the right to alter product specifications without notice.



**mira**  
SHOWERS