

Thank you for your interest in our steam shower range. The following information is designed to give a brief outline of the installation requirements for a Di Vapor steam shower. If you have any further enquiries regarding any of our units please do not hesitate to contact us.

#### ATTENTION

This steam shower is entirely free-standing and requires no further structural support. All pipe connections are designed with excess length to allow the unit to be pulled away from the wall to allow for servicing after installation.

#### DELIVERY INFORMATION

This unit will be delivered in reinforced wooden crates by a dedicated delivery vehicle. **Please inform us of any access restrictions your property may have when placing your order.**

To include packaging please expect:

3 x Crates in total with a **combined weight of:**

**330KG**

When your goods arrive, please check the goods and packaging for any surface damage. Please report all damages to us within **48 hours** to ensure a claim can be raised.

#### ELECTRICAL REQUIREMENTS

- A dedicated **16 AMP** electrical supply is required for operation.
- All units are supplied with an RCD (*Residual Current Device*) reset switch on the main unit flex.
- The unit can be powered via an isolated fused spur connected directly back to the consumer box fitted with RCD.
- Alternativley, the unit can be powered via an I.P.56 rated wall socket

#### WATER & PRESSURE REQUIREMENTS

- Both Hot & Cold water supplies must be of high pressure. (*Minimum of 9 litres per minute per water water feed - combined LPM of 18*).
- The unit requires a supply pressure of **2.0 - 3.0 bar**, typically provided by most high pressure water systems.
- **Di Vapors units will work with Combination Boilers, Pressurised Pump systems and Pressurised cylinder systems.**
- The water supply must be balanced (*equal pressure across both supplies*).
- If the water pressure is not balanced, it may cause permanent damage to the thermostatic valve.
- **Fitting a Pressure Equalising Valve (PEV) will ensure that the water supply to the unit is constantly equal.**
- Pipework must be recessed to allow the finished unit to sit flush against the wall.
- Use full bore water lever ball valves for the hot and cold supply to enable quick & easy shutoff of the supply.
- All units come complete with flexible piping for the hot and cold water feeds. A flexible shower waste fitting is also supplied with all units - enquire for further details.



Full bore ball lever valves should be used with the water supplies.



A PEV valve will balance your incoming water pressure.

#### KEY

- H** Hot Water Feed
- C** Cold Water Feed
- P** Power Supply (16A)

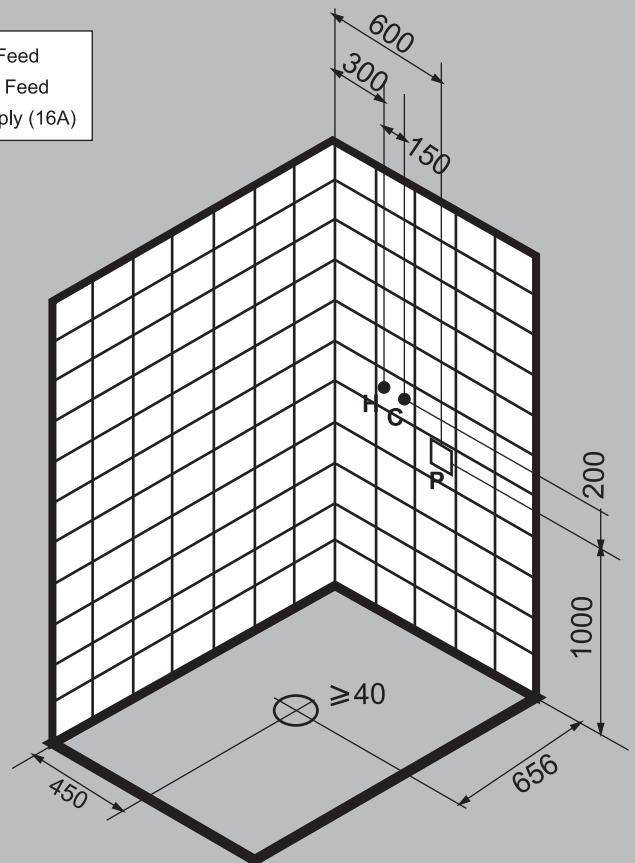

**PLEASE ENSURE THAT WALLS AND FLOORS ARE LEVEL**

#### DRAINAGE GUIDELINES

This unit comes complete with a "low profile" shower tray. The tray must be installed in a room with removable floorboards to allow access underneath the tray.

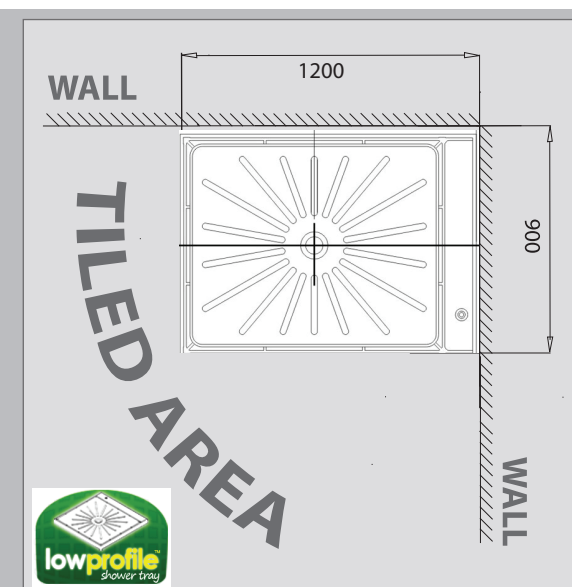
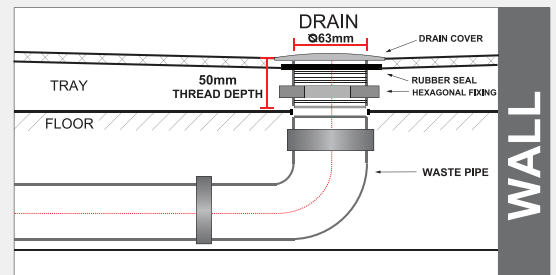

#### FLOORING

Prior to installation it is recommended that the walls and floor are prepared prior to arrival.

Ensure that the floor is level. Tiling the floor and surrounding area is advised - Sliding the unit away from the wall or corner will be easier.

All cabins are sealed units so tiling behind is not necessary.